

**TECHNICAL SPECIFICATION:**

1. All parts of fan should be properly assembled, no oil or dirt on the surface, no obvious distortion, mechanical damage and other defects.
2. Fan rotation is flexible, no delay no operation sound, no scratch and other undesirable phenomena.
3. The safety requirement of fan is performed according to GB12350-2009, the electrical strength is 1500V•min, and the insulation resistance is not less than 100M Ω at room temperature.
4. Motor insulation class, F CLASS.
5. Motor protection level, IP44, fan protection level, IP2X.
6. The fan balance level is: 1379± 10% r/min high G6. 3, vibration value is less than 5.4mm/s.
7. MAER box.
8. Built-in heat protector.

Test data at free:

Connection	UAC (V)±5%	f (Hz)	P1 (W)±10%	I (A)±10%	n (r/min)±10%	Noise db(A)
	3~380V	50	691	1.31	1379	73

**Performance parameters at key point:**

	psf	I	P1	n	Q	Note
	(pa)	(A)	(W)	(r/min)	(m³/h)	
①	0	1.22	611	1395	8718	
②	84	1.31	691	1379	7273	
③	127	1.37	733	1369	6178	MAX EFF.
④	145	1.40	752	1366	5543	IMAX

PS: Fan working performance tested with MAER wall plate, and under standard atmospheric pressure at 20°C

Psf (pa)

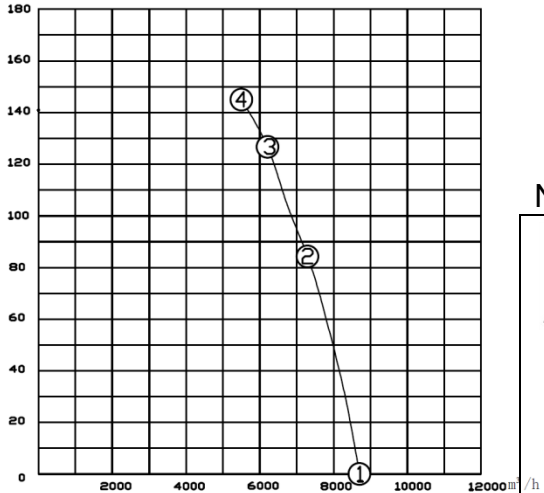

**WIRING DIAGRAM**

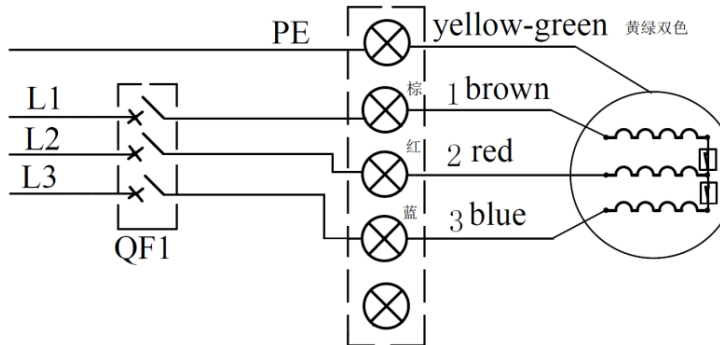

**Nameplate:**

**YSWF102L60P4-570N-500 S 3~380V50Hz 10μF / 450V**  
 733W 1.37A 1369r/min @ 127Pa  
 CL. F IP54 2018/07  
 Tel: +380678807231, +380500679006  
 web: [www.iceteco.com](http://www.iceteco.com)  
 e-mail: [iceteko@gmail.com](mailto:iceteko@gmail.com)



	Product model	<b>YSWF102L60P4-570N-500S</b>
	Product type	External rotor axial flow fan
	Customer	乌克兰 (Ukraine)
	Product number	MAER - 1605245
	Certification	CE, CCC

**Condition of use:**

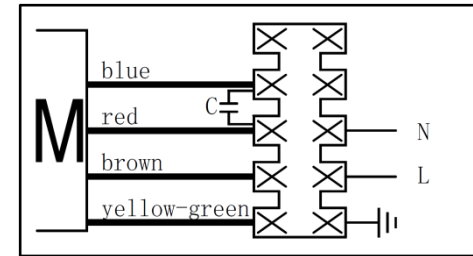

- 1) Voltage and frequency: 3 ~ 380V + 5% (50 Hz)
- 2) Qualification requirements: Terminal block, the recommended standard of lead wire is not less than 0.75mm².
- 3) Installation position: vertical or upward.
- 4) Ambient temperature: -40 ~ 80°C.

**THE EXTERNAL WIRING DIAGRAM:**



**MARK**

**MAER** AXIAL FAN MOTOR  
 MOTORS & FANS  
 MODEL: **YSWF102L60P4-570N-500 SUCTION**  
**4D-500-S-102L60**  
 VOLTAGE: 380V / 50Hz  
 N.W/G.W. 9.3/10.8 kg  
 MEAS: 55x55x21 cm  
 CL. F WITH TERMINAL BOX  
 20180616X

		The signature	(date)(month)(year)	ZHEJIANG MAER FAN MOTOR CO., LTD.
state	Deliver before			Product Specification
	After the confirmation			
drawing				
audit				
approval				