



Level



Pressure



Flow



Temperature

Liquid
Analysis

Registration

Systems
Components

Services



Solutions

Technical Information

Micropilot M FMR250

Level-Radar

Continuous and non-contact level measurement in solids.
Cost-effective 4 to 20 mA 2-wire technology.



Application

The Micropilot M performs continuous, non-contact level measurement especially in powdery to granular bulk solids. Additionally it can be used in liquids as well. Dust, filling noises, temperature layers and gas stratification do not affect measurement.

Typical areas of application are:

- Level measurement in tall silos with extremely dusty bulk solids e.g. cement, raw meal or animal feed.
- Applications with high temperature requirements up to 200 °C (392 °F), e.g. clinker or fly ash.
- Applications with highly abrasive bulk solids e.g. ferrite.

The FMR250 with DN80 or DN100 horn antenna for all standard applications, particularly also for small nozzle sizes.

The FMR250 with DN200 or DN250 parabolic antenna offers high beam focussing of 4° or 3.5° and is thus ideal for applications with many installations.

Your benefits

- 2-wire technology, low price:
2-wire technology reduces wiring costs and allows easy implementation into existing systems.
- Non-contact measurement:
Measurement is almost independent from product properties.
- Easy on-site operation via menu-driven alphanumeric display.
- Easy commissioning, documentation and diagnostics via Endress+Hauser operating software.
- Integrated air purge connection for extremely dusty conditions or media tending to create build-up.
- Max. measuring range 70 m (230 ft).
- Suitable for process temperatures up to 200 °C (392 °F).
- HART or PROFIBUS PA respectively FOUNDATION Fieldbus protocol.
- Optional remote display and operation.
- Used for level monitoring (MIN, MAX) up to SIL 2 as per IEC 61508 / IEC 61511.

Table of contents

Function and system design	3	Operating conditions: Process	25
Measuring principle	3	Process temperature range / Process pressure limits	25
Equipment architecture	4	Dielectric constant	25
Input	7	Mechanical construction	26
Measured variable	7	Design, dimensions	26
Measuring range	7	Endress+Hauser UNI flange	29
Measuring conditions	8	Weight	30
Operating frequency	8	Material (not in contact with process)	31
Transmitting power	8	Material (in contact with process)	33
Output	9	Process connection	34
Output signal	9	Seal	34
Signal on alarm	9	Antenna	34
Linearization	9	Human interface	34
Protocol specific data	10	Operation concept	34
Auxiliary energy	13	Display elements	34
Electrical connection	13	Operating elements	35
Cable gland	13	On-site operation	36
Terminals	13	Remote operation	37
Terminal assignment	14	Certificates and approvals	40
Load HART	15	CE approval	40
Supply voltage	15	Ex approval	40
Cable entry	16	Overspill protection	40
Power consumption	16	External standards and guidelines	40
Current consumption	16	RF approvals	40
Ripple HART	16	Ordering information	41
Max. noise HART	16	Micropilot M FMR250	41
Overvoltage protector	16	Accessories	44
Performance characteristics	17	Weather protection cover	44
Reference operating conditions	17	Remote display FHX40	45
Maximum measured error	17	Horn cover for 80 mm (3") and 100 mm (4") horn antenna	46
Resolution	17	Commubox FXA195 HART	47
Reaction time	17	Commubox FXA291	47
Influence of ambiente temperature	17	ToF Adapter FXA291	47
Operating conditions: Installation	18	Documentation	48
Installation instructions	18	Technical Information	48
Beam angle	19	Operating Instructions	48
Installation in vessel FMR250	20	Certificates	49
FMR250 with top target positioner	23	Safety manual	49
Integrated air purge connection	23		
Operating conditions: Environment	24		
Ambient temperature range	24		
Storage temperature	24		
Climate class	24		
Degree of protection	24		
Vibration resistance	24		
Cleaning of the antenna	24		
Electromagnetic compatibility	24		

Function and system design

Measuring principle

The Micropilot is a "downward-looking" measuring system, operating based on the time-of-flight method. It measures the distance from the reference point (process connection) to the product surface. Radar impulses are emitted by an antenna, reflected off the product surface and received again by the radar system.

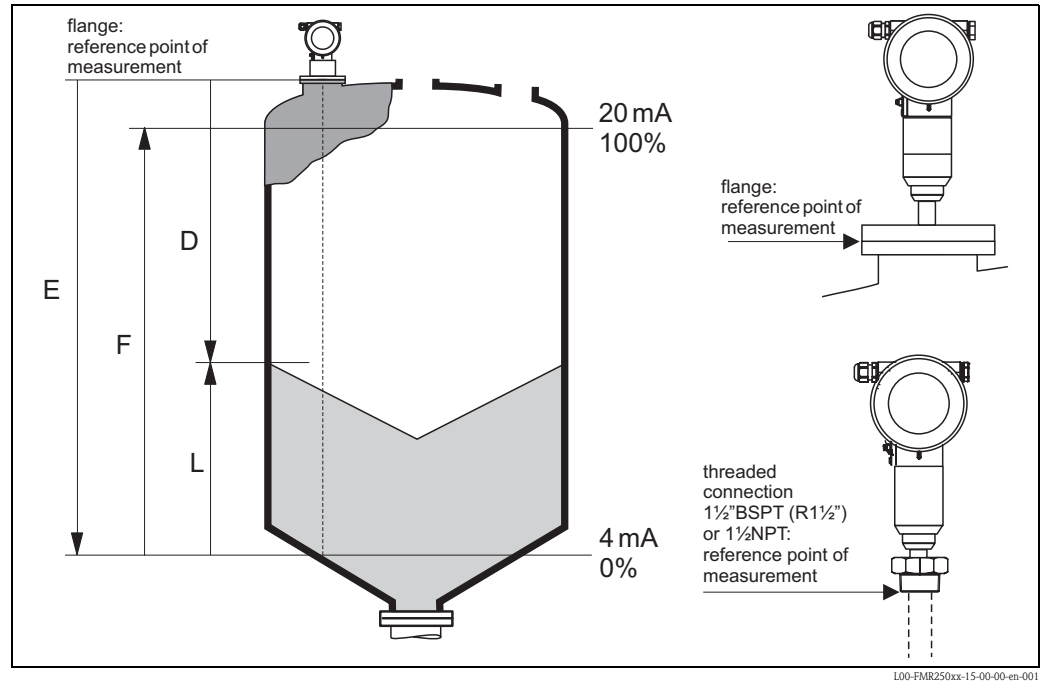

Input

The reflected radar impulses are received by the antenna and transmitted into the electronics. A microprocessor evaluates the signal and identifies the level echo caused by the reflection of the radar impulse at the product surface. The unambiguous signal identification is accomplished by the PulseMaster® software, based on many years of experience with time-of-flight technology.

The distance "D" to the product surface is proportional to the time of flight "t" of the impulse:

$$D = c \cdot t / 2,$$

with "c" being the speed of light.

Based on the known empty distance "E", the level "L" is calculated:

$$L = E - D$$

Refer to the above figure for the reference point for "E".

The Micropilot is equipped with functions to suppress interference echoes. The user can activate these functions. They ensure that interference echoes (i.e. from internals and struts) are not interpreted as level echo.

Output

The Micropilot is commissioned by entering an empty distance "E" (=zero), a full distance "F" (=span) and an application parameter. The application parameter automatically adapts the instrument to the process conditions. For models with a current output, the factory adjustment for zero point "E" and span "F" is 4 mA and 20 mA. For digital outputs and the display module, the factory adjustment for zero point "E" and span "F" is 0 % and 100 %.

A linearization with max. 32 points, based on a table entered either manually or semi-automatically, can be activated locally or remotely. This function provides a measurement in engineering units and a linear output signal for spheres, horizontal cylindrical tanks and vessels with conical outlet.

Equipment architecture

Stand-alone

The instrument provides a 4 to 20 mA output with HART protocol, or PROFIBUS PA respectively FOUNDATION Fieldbus communication.

4 to 20 mA output with HART protocol.

The complete measuring system consists of:

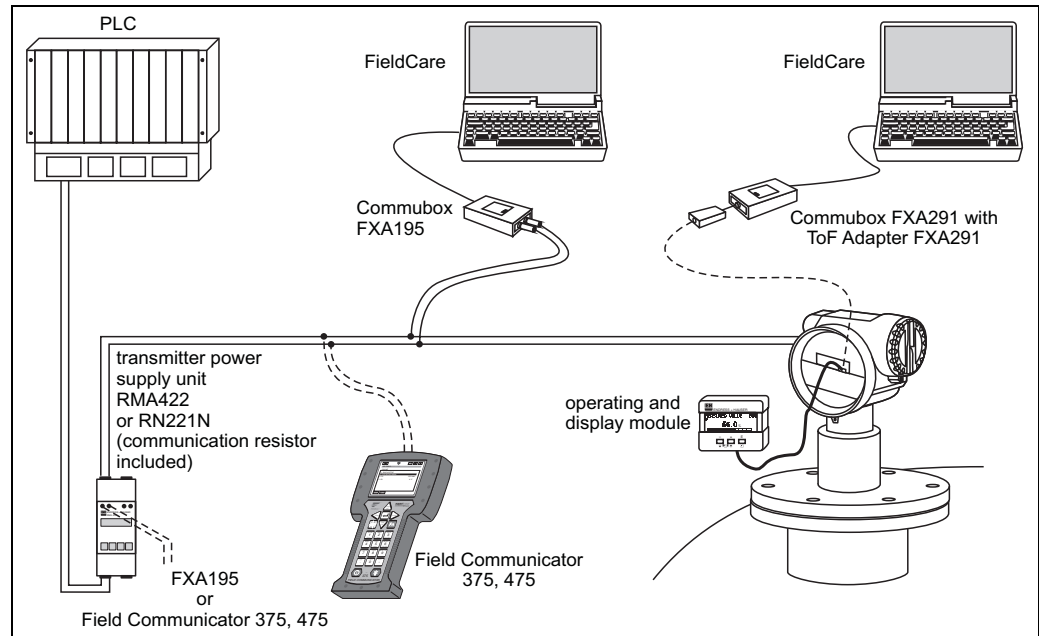

On-site operation

- with display and operating module ,
- with a Personal Computer, FXA291 with ToF Adapter FXA291 (USB) and the operating software "FieldCare".
FieldCare is a graphical operating software for instruments from Endress+Hauser (radar, ultrasonic, guided micro-impulse). It assists with commissioning, securing data, signal analysis and documentation of the measuring point.

Remote operation

- with Field Communicator 375, 475,
- with a Personal Computer, Commubox FXA195 and the operating software "FieldCare".

System integration via PROFIBUS PA

A maximum of 32 transmitters (8 if mounted in an explosion hazardous location Ex ia IIC according to FISCO-model) can be connected to the bus. The segment coupler provides the operating voltage to the bus. Both on-site as well as remote operation are possible. The complete measuring system consists of:

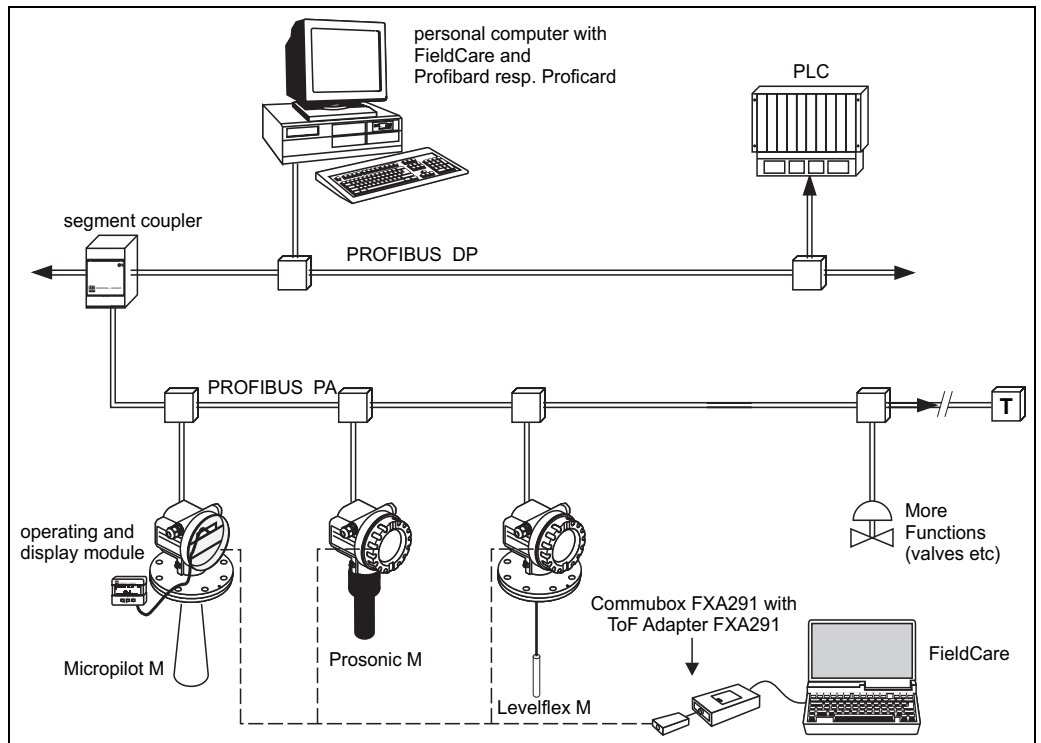

L00-FMxxxxxx-14-00-06-en-001

System integration via FOUNDATION Fieldbus

A maximum of 32 transmitters (standard, Ex em or Ex d) can be connected to the bus. For protection class Ex ia IIC: the max. number of transmitters depends on the established rules and standards for intrinsically safe circuits (EN 60079-14), proof of intrinsically safety. Both on-site as well as remote operation are possible. The complete measuring system consists of:

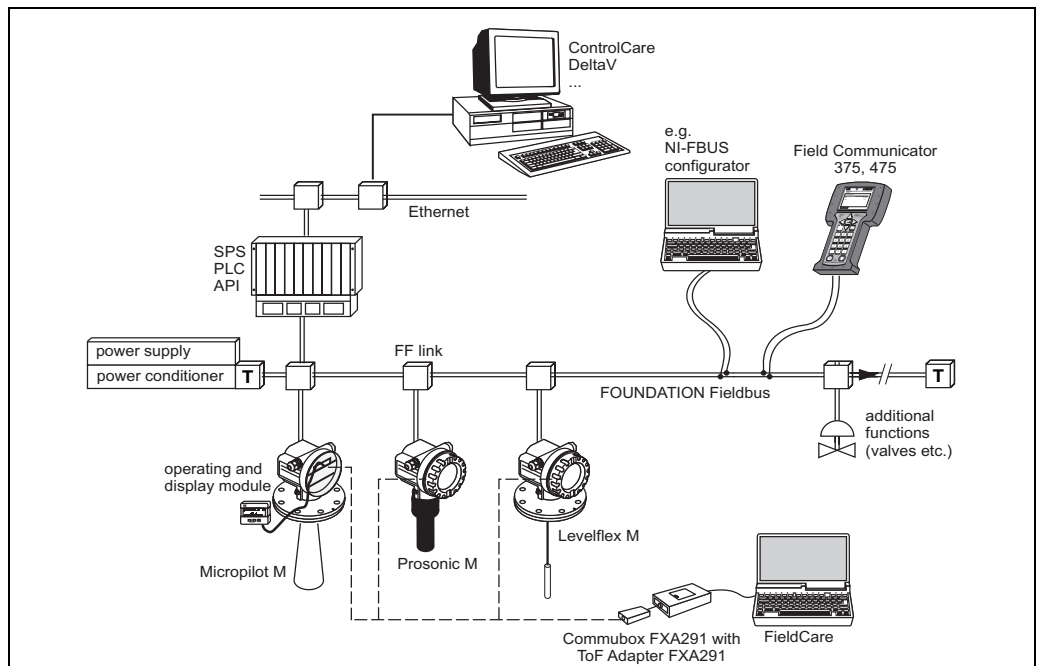

L00-FMxxxxxx-14-00-06-en-011

System integration via Fieldgate

Vendor Managed Inventory

By using Fieldgates to interrogate tank or silo levels remotely, suppliers of raw materials can provide their regular customers with information about the current supplies at any time and, for example, account for them in their own production planning. For their part, the Fieldgates monitor the configured level limits and, if required, automatically activate the next supply. The spectrum of options here ranges from a simple purchasing requisition via e-mail through to fully automatic order administration by coupling XML data into the planning systems on both sides.

Remote maintenance of measuring equipment

Fieldgates not only transfer the current measured values, they also alert the responsible standby personnel, if required, via e-mail or SMS. In the event of an alarm or also when performing routine checks, service technicians can diagnose and configure connected HART devices remotely. All that is required for this is the corresponding HART operating software (e.g. FieldCare) for the connected device. Fieldgate passes on the information transparently, so that all options for the respective operating software are available remotely. Some on-site service operations can be avoided by using remote diagnosis and remote configuration and all others can at least be better planned and prepared.

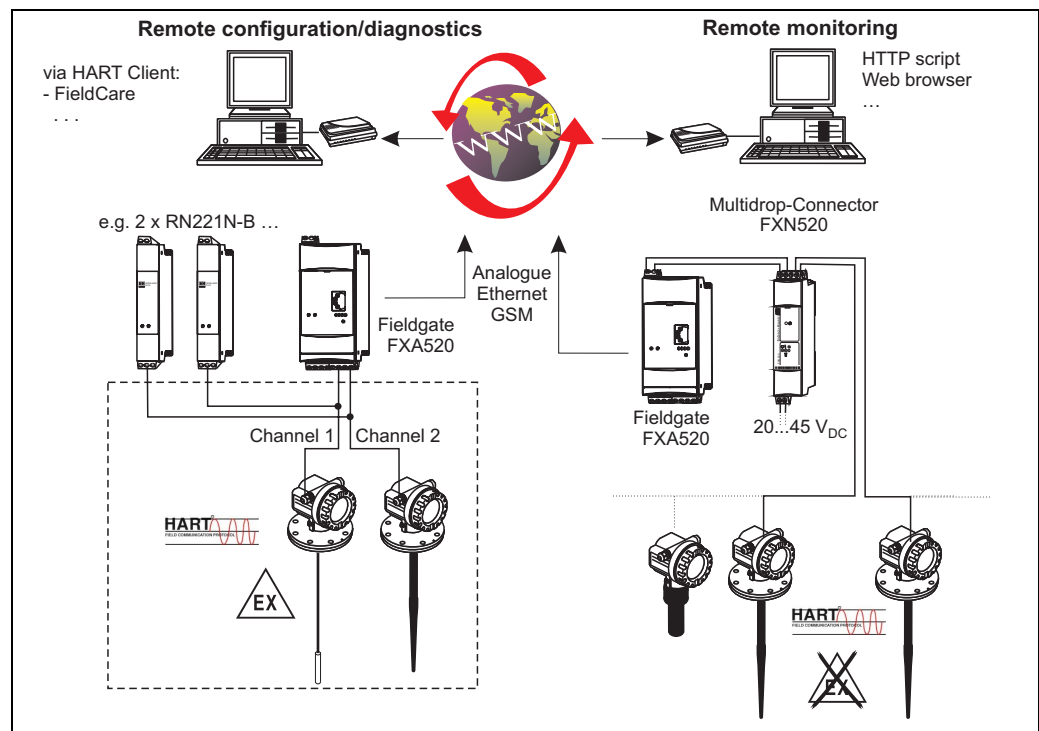

Note!

The number of instruments which can be connected in multidrop mode can be calculated by the "FieldNetCalc" program. A description of this program can be found in Technical Information TI00400F/00/EN (Multidrop Connector FXN520). The program is available from your Endress+Hauser sales organisation or in the internet at: www.endress.com → Select your country → Download → Search: Fielnetcalc.

Input

Measured variable The measured variable is the distance between a reference point (→  3) and a reflective surface (i.e. medium surface). The level is calculated based on the vessel height entered. The level can be converted into other units (volume, mass) by means of a linearization (32 points).

Measuring range The usable measuring range depends on the size of the antenna, the reflectivity of the medium, the mounting location and eventual interference reflections. The maximum configurable range is 70 m (230 ft).

Reduction of the max. possible measuring range through:



- Media with poor reflection properties (= small DC). For examples refer to table below.
- Angle of repose.
- Extremely loose surfaces of bulk solids, e.g. bulk solids with low bulk weight for pneumatic filling.
- Build-up, above all of moist products.

The following table describes the media groups and the dielectric constant ϵ_r .

Media group	DC (ϵ_r)	Examples	Signal attenuation
A	1.6 to 1.9	– Plastic granulate – White lime, special cement – Sugar	19 to 16 dB
B	1.9 to 2.5	– Portland cement, plaster	16 to 13 dB
C	2.5 to 4	– Grain, seeds – Ground stones – Sand	13 to 10 dB
D	4 to 7	– Naturally moist (ground) stones, ores – Salt	10 to 7 dB
E	> 7	– Metallic powder – Carbon black – Coal	< 7 dB

The respective lower group applies for very loose or loosened bulk solids.

Antenna selection

Antenna type	Application
FMR250-*D*... (DN80) FMR250-*E*... (DN100) 	The FMR250 with DN80 or DN100 horn antenna for all standard applications, particularly also for small nozzle sizes. To achieve an optimised signal strength it is recommended to use an antenna with as large as possible diameter. In small tanks in particular, an antenna extension should not be used wherever possible to optimize dynamics at close range.
FMR250-*G*... (DN200) FMR250-*H*... (DN250) ¹⁾ 	The FMR250 with DN200/DN250 parabolic antenna offers high beam focussing of 4°/3.5° and is thus ideal for applications with many installations.

1) increased near distance dynamics

Measuring conditions

- The measuring range begins, where the beam hits the bottom. Particularly with conical outlets the level cannot be detected below this point. The maximum measuring range can be increased in such applications by using a top target positioner (→ 18).
- In case of media with a low dielectric constant (groups A and B), the bottom can be visible through the medium at low levels. In order to guarantee the required accuracy in these cases, it is recommended to position the zero-point at a distance **C** above the bottom (see Fig.).
- In principle it is possible to measure up to the tip of the antenna with the FMR250. However, due to considerations regarding abrasion and build-up and depending on the orientation of the product surface (angel of repose), the end of the measuring range should be at a distance of approx. **A** (see Fig.). If required, and if some conditions (high DC value, flat angle of repose) are met, shorter distances can be achieved.

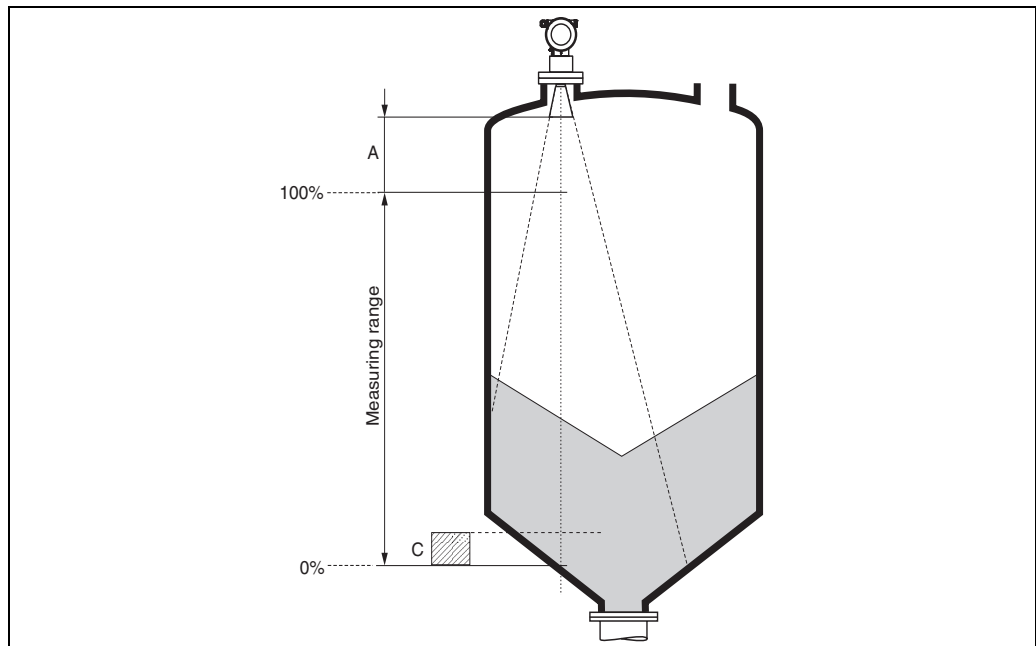

L00-FMR250xx-17-00-00-en-001

A [mm (in)]	C [mm (in)]
approx 400 (15.7)	approx 50 to 150 (1.97 to 5.91)

Operating frequency

- K-band

Transmitting power

Distance	Average energy density in beam direction measuring range = 70 m (230 ft)
1 m (3.3 ft)	< 64 nW/cm ²
5 m (16 ft)	< 2.5 nW/cm ²

Output

Output signal

HART

Signal coding	FSK ± 0.5 mA over currency signal
Data transmission rate	1200 Baud
Galvanic isolation	Yes (IO-Module)

PROFIBUS PA

Signal coding	Manchester Bus Powered (MBP)
Data transmission rate	31.25 KBit/s, voltage mode
Galvanic isolation	Yes (IO-Module)

FOUNDATION Fieldbus

Signal coding	Manchester Bus Powered (MBP)
Data transmission rate	31.25 KBit/s, voltage mode
Galvanic isolation	Yes (IO-Module)

Signal on alarm

Error information can be accessed via the following interfaces:

- Local display:
 - Error symbol
 - Plain text display
- Current output, signal on error can be selected (e.g. according to NAMUR recommendation NE43).
- Digital interface

Linearization

The linearization function of the Micropilot M allows the conversion of the measured value into any unit of length or volume. Linearization tables for calculating the volume in cylindrical vessels are pre-programmed. Other tables of up to 32 value pairs can be entered manually or semi-automatically.

Protocol specific data

HART

Manufacturer ID	000011 hex
Device Type Code	001E hex
Transmitter specific revision	05 hex
HART specification	5.0
DD-Files	Information and files can be found: <ul style="list-style-type: none"> ■ www.endress.com ■ www.hartcom.org
Load HART	Min. 250 Ω
Device variables	Primary value: level or volume ¹⁾
Supported features	<ul style="list-style-type: none"> ■ Burst mode ■ Additional Transmitter Status

1) according to configuration

PROFIBUS PA

Manufacturer ID	000011 hex
Ident number	1522 hex
Profile Version	3.0
GSD file	Information and files can be found:
GSD file version	<ul style="list-style-type: none"> ■ www.endress.com ■ www.profibus.org
Output values	Primary value: measured value Secondary value: distance
Input values	Display value of PLC
Supported features	<ul style="list-style-type: none"> ■ I&M ■ Identification & Maintenance

FOUNDATION Fieldbus H1

Manufacturer ID	452B48
Device Type	100F hex
Device Revision	05 hex
DD Revision	Information and files can be found: <ul style="list-style-type: none"> ■ www.endress.com ■ www.fieldbus.org
CFF Revision	
Devise Tester Version (ITK Version)	5.00
ITK Test Campaign Number	IT042000
Link Master (LAS) Capable	yes
Link Master / Basic Device Selectable	yes, default: Basic Device
Node Address	Default: 247
Features supported	Following methods are supported: <ul style="list-style-type: none"> ■ Basic setup ■ Safety settings ■ Acknowledge alarm ■ Linearisation ■ Extended calibration ■ Output ■ System parameters ■ Lock TB Manufacturer parameters

Virtual Communication Relationship (VCRs)

Number of VCRs	24
Number of Link Objects in VFD	24
Permanent entries	1
Client VCRs	0
Server VCRs	24
Source VCRs	23
Sink VCRs	0
Subscriber VCRs	23
Publisher VCRs	23

Devise Link Capabilities

Slot time	4
Min. inter PDU delay	4
Max. response delay	10

Transducer Blocks		
Block	Content	Output values
Sensor Block	contains all parameters related to the measurement	<ul style="list-style-type: none"> ■ level or volume¹⁾ (channel 1) ■ distance (channel 2)
Diagnosic Block	contains diagnostic information	no output values
Display Block	contains parameters to configure the local display	no output values

1) depending on the configuration of the sensor block

Function Blocks				
Block	Content	Number of blocks	Execution time	Functionality
Resource Block	The Resource Block contains all the data that uniquely identifies the field device. It is an electronic version of a nameplate of the device.	1	—	enhanced
Analog Input 1	The AI block takes the manufacturer's input data, selected by channel number, and makes it available to other function blocks at its output.	2	30 ms	standard
Analog Input 2			30 ms	
PID Block	The PID block serves as proportional-integral-derivative controller and is used almost universally to do closed-loop-control in the field including cascade and feedforward.	1	80 ms	standard
Arithmetic Function Block	This block is designed to permit simple use of popular measurement math functions. The user does not have to know how to write equations. The math algorithm is selected by name, chosen by the user for the function to be done.	1	50 ms	standard
Input Selector Block	The input selector block provides selection of up to four inputs and generates an output based on the configured action. This block normally receives its inputs from AI blocks. The block performs maximum, minimum, middle, average and 'first good' signal selection.	1	30 ms	standard
Signal Characterizer Block	The signal characterizer block has two sections, each with an output that is a non-linear function of the respective input. The non-linear function is determined by a single look-up table with 21 arbitrary x-y pairs.	1	40 ms	standard
Integrator Block	The Integrator Function Block integrates a variable as a function of the time or accumulates the counts from a Pulse Input block. The block may be used as a totalizer that counts up until reset or as a batch totalizer that has a setpoint, where the integrated or accumulated value is compared to pre-trip and trip settings, generating discrete signals when these settings are reached.	1	60 ms	standard

Additional Function Block Information	
Instantiable Function Blocks	No
Number of instanciable blocks	—

Auxiliary energy

Electrical connection

Terminal compartment

Three housings are available:

- Aluminium housing F12 with additionally sealed terminal compartment for:
 - standard,
 - Ex ia,
 - Ex ia with dust Ex.
- Aluminium housing T12 with separate terminal compartment for:
 - standard,
 - Ex d,
 - Ex ia (with overvoltage protection),
 - dust Ex.
- 316L housing F23 for:
 - standard,
 - Ex ia,
 - Ex ia with dust Ex.

The electronics and current output are galvanically isolated from the antenna circuit.

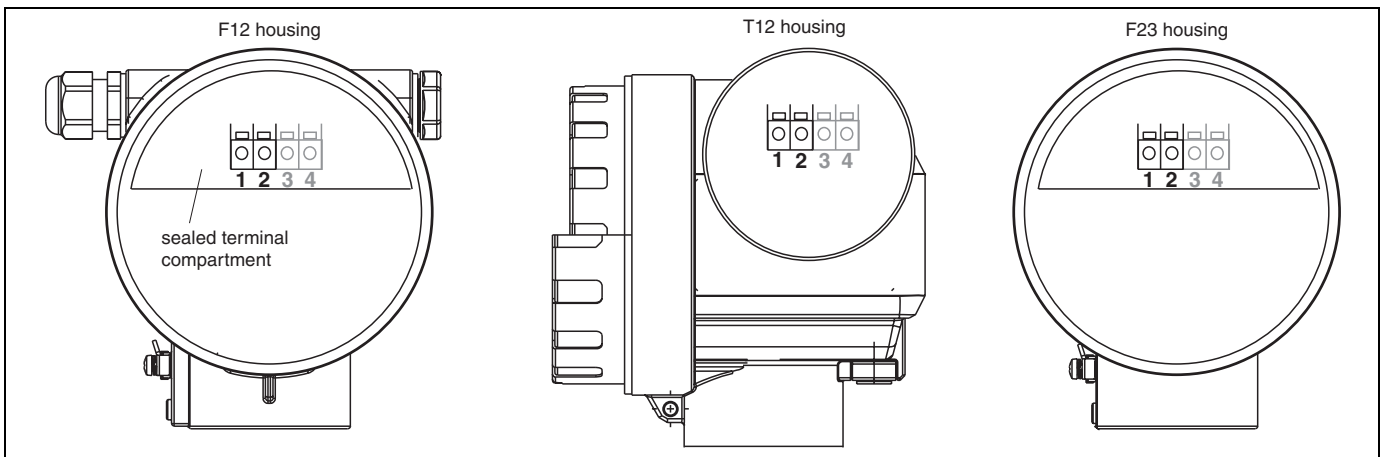

L00-FMR2xxxx-04-00-00-en-019

Cable gland

Type		Clamping area
Standard, EEx ia, IS	Plastic M20x1.5	5 to 10 mm (0.2 to 0.39 in)
EEx em, EEx nA	Metal M20x1.5	7 to 10.5 mm (0.28 to 0.41 in)

Terminals

For wire cross-sections of 0.5 to 2.5 mm² (20 to 14 AWG).

Terminal assignment

2-wire, 4 to 20 mA with HART

The 2-wire cable is connected to the screw terminals in the terminal compartment.

Cable specification:

A standard installation cable is sufficient if only the analogue signal is used. Use a screened cable when working with a superimposed communications signal (HART).

Note!

- Protective circuitry against reverse polarity, RFI, and over-voltage peaks is built into the device (refer to TI241F/00/EN "basics for EMC-tests").
- See TI402F/00/EN for connection to Tank Side Monitor NRF590.

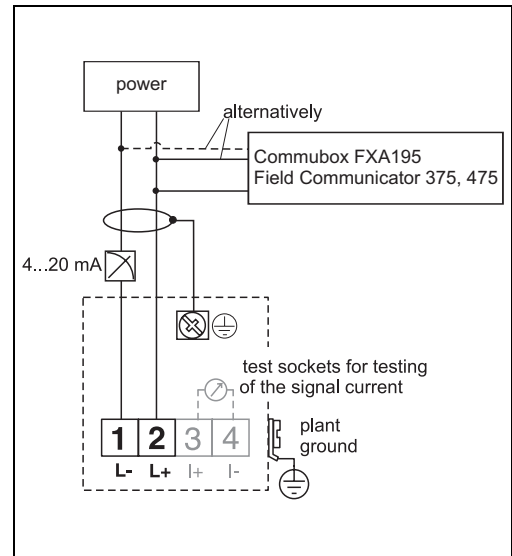

L00-FMxxxxxx-04-00-00-en-015

PROFIBUS PA

The digital communication signal is transmitted to the bus via a 2-wire connection. The bus also provides the auxiliary energy.

For further information on the network structure and earthing and for further bus system components such as bus cables, see the relevant documentation, e.g. Operating Instructions BA034S/04/EN "Guidelines for planning and commissioning PROFIBUS DP/PA" and the PNO Guideline.

Cable specification:

Use a twisted, screened two-wire cable, preferably cable type A.

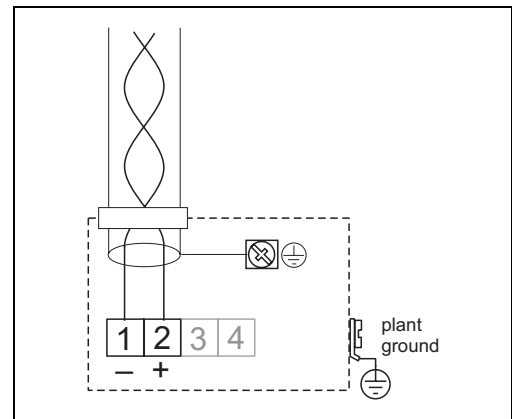

L00-FMxxxxxx-04-00-00-en-022

Note!

For further information on the cable specifications, see Operating Instructions BA034S/04/EN "Guidelines for planning and commissioning PROFIBUS DP/PA", PNO Guideline 2.092 "PROFIBUS PA User and Installation Guideline" and IEC61158-2 (MBP).

FOUNDATION Fieldbus

The digital communication signal is transmitted to the bus via a 2-wire connection. The bus also provides the auxiliary energy.

For further information on the network structure and earthing and for further bus system components such as bus cables, see the relevant documentation, e.g. Operating Instructions BA013S/04/EN "FOUNDATION Fieldbus Overview" and the FOUNDATION Fieldbus Guideline.

Cable specification:

Use a twisted, screened two-wire cable, preferably cable type A.

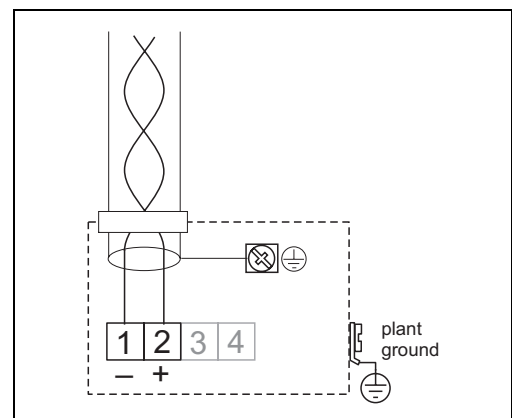

L00-FMxxxxxx-04-00-00-en-022

Note!

For further information on the cable specifications, see Operating Instructions BA013S/04/EN "FOUNDATION Fieldbus Overview", FOUNDATION Fieldbus Guideline and IEC61158-2 (MBP).

Load HART

Minimum load for HART communication: 250 Ω

Supply voltage

HART

The following values are the voltages across the terminals directly at the instrument:

Communication		Current consumption	Terminal voltage
HART	standard	4 mA	16 V to 36 V
		20 mA	7.5 V to 36 V
	Ex ia	4 mA	16 V to 30 V
		20 mA	7.5 V to 30 V
	Ex d	4 mA	16 V to 30 V
		20 mA	11 V to 30 V
	dust Ex	4 mA	16 V to 30 V
		20 mA	11 V to 30 V
Fixed current, adjustable e.g. for solar power operation (measured value transferred at HART)	standard	11 mA	10 V ¹⁾ to 36 V
	Ex ia	11 mA	10 V ¹⁾ to 30 V
Fixed current for HART Multidrop mode	standard	4 mA ²⁾	16 V to 36 V
	Ex ia	4 mA ²⁾	16 V to 30 V

1) Short-term min. start-up voltage: 11.4 V

2) Start up current 11 mA.

PROFIBUS PA and FOUNDATION Fieldbus

The following values are the voltages across the terminals directly at the device:

Type	Terminal voltage
Supply voltage	9 V to 30 V (Ex) ¹⁾ 9 V to 32 V (non-Ex) max. voltage: 35 V
Device (Lift off) minimum voltage	9 V
Polarity sensitive	No
FISCO/FNICO compliant in accordance to IEC60079-27	Yes

1) There may be additional restrictions for devices with an explosion protection certificate. Refer to the notes in the appropriate safety instructions (XA).

Cable entry ■ Cable gland: M20x1,5 (for Ex d: cable entry)
 ■ Cable entry: G½ or ½NPT

Power consumption min. 60 mW, max. 900 mW

Current consumption

HART

Device basic current	3,6 to 22 mA, for HART Multidrop: start up current is 11 mA
Breakdown signal (NAMUR NE43)	adjustable

PROFIBUS PA

Device basic current	max. 13 mA
Error current FDE (Fault Disconnection Electronic)	0 mA

FOUNDATION Fieldbus

Device basic current	15 mA
Device In-rush current	≤ 15 mA
Error current FDE (Fault Disconnection Electronic)	0 mA

FISCO

U_i	17,5 V
I_i	500 mA; with overvoltage protection 273 mA
P_i	5,5 W; with overvoltage protection 1,2 W
C_i	5 nF
L_i	0,01 mH

Ripple HART 47 to 125 Hz: $U_{ss} = 200 \text{ mV}$ (at 500 Ω)

Max. noise HART 500 Hz to 10 kHz: $U_{eff} = 2.2 \text{ mV}$ (at 500 Ω)

Overvoltage protector

The level transmitter Micropilot M with T12-housing (housing version "D", see ordering information, → 41ff.) is equipped with an internal overvoltage protector (600 V surge arrester) according to EN/IEC 60079-14 or EN/IEC 60060-1 (impulse current test 8/20 μs , $\hat{I} = 10 \text{ kA}$, 10 pulses). Connect the metallic housing of the Micropilot M to the tank wall or screen directly with an electrically conductive lead to ensure reliable potential matching.

Performance characteristics

Reference operating conditions	<ul style="list-style-type: none"> ■ temperature = $+20\text{ °C} \pm 5\text{ °C}$ ($+68\text{ °F} \pm 41\text{ °F}$) ■ pressure = 1013 mbar abs. $\pm 20\text{ mbar}$ (15.19 psi $\pm 0.3\text{ psi}$) ■ relative humidity (air) = $65\% \pm 20\%$ ■ ideal reflector ■ no major interference reflections inside the signal beam
Maximum measured error	<p>Typical statements for reference conditions, include linearity, repeatability, and hysteresis:</p> <ul style="list-style-type: none"> ■ up to 1 m (3.3 ft): $\pm 30\text{ mm}$ ($\pm 1.18\text{ in}$) ■ ex 1 m (3.3 ft): $\pm 15\text{ mm}$ ($\pm 0.59\text{ in}$) (or 0.04% of measuring range, whatever is larger)
Resolution	Digital / analog in % 4 to 20 mA: 1 mm (0.04 in)/ 0.03 % of measuring range
Reaction time	The reaction time depends on the parameter settings (min. 1 s). In case of fast level changes, the instrument needs the reaction time to indicate the new value.
Influence of ambiente temperature	<p>The measurements are carried out in accordance with EN61298-3:</p> <ul style="list-style-type: none"> ■ digital output (HART, PROFIBUS PA, FOUNDATION Fieldbus): <ul style="list-style-type: none"> – average T_K: 5 mm (0.2 in) /10 K, max. 15 mm (0.59 in) over the entire temperature range -40 °C to $+80\text{ °C}$ (-40 °F to $+176\text{ °F}$). ■ Current output (additional error, in reference to the span of 16 mA): <ul style="list-style-type: none"> – Zero point (4 mA) average T_K: 0,03 %/10 K, max. 0,45 % over the entire temperature range -40 °C to $+80\text{ °C}$ (-40 °F to $+176\text{ °F}$). – Span (20 mA) average T_K: 0,09 %/10 K, max. 0,95 % over the entire temperature range -40 °C to $+80\text{ °C}$ (-40 °F to $+176\text{ °F}$).

Operating conditions: Installation

Installation instructions

Orientation

- Recommended distance (1) wall – **outer edge** of nozzle: $\sim 1/6$ of vessel diameter. However, the device should not, under any circumstances, be mounted less than 20 cm (7.87 in) from the vessel wall.
Note!
If the tank wall is not smooth (corrugated metal, welding seams, irregularities etc.) the distance from the wall should be kept as large as possible.
If necessary, use a top target positioner to prevent interference reflections from the tank wall.
- Not in the centre (3), interference can cause signal loss.
- Not above the fill stream (4).
- It is recommended to use a weather protection cover (2) in order to protect the transmitter from direct sun or rain. Assembly and disassembly is simply done by means of a tension clamp (→ 44, "Accessories").
- In extremely dusty applications, the integrated air purge connection can prevent clogging of the antenna.

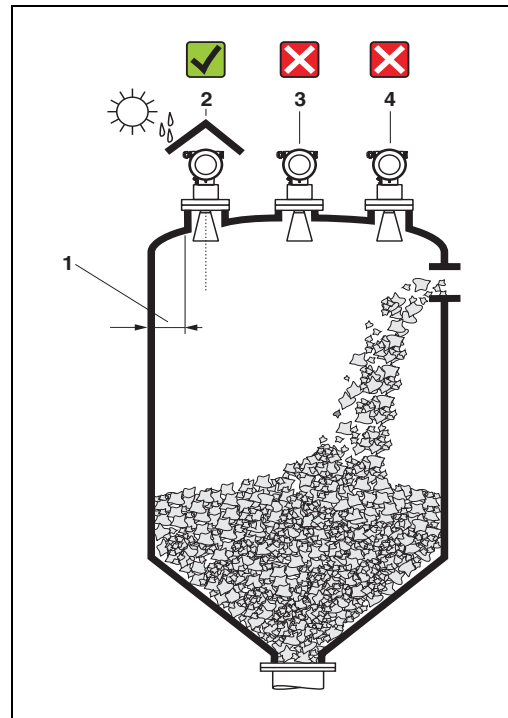

Vessel installations

- Avoid any installations (1), like limit switches, struts, etc., inside the signal beam (→ 19, "Beam angle").
- Symmetrical installations (2), i.e. reinforcing rings, heating coils, etc., can also interfere with the measurement.

Optimization options

- Antenna size: the bigger the antenna, the smaller the beam angle, the less interference echoes.
- Mapping: the measurement can be optimized by means of electronic suppression of interference echoes.
- Antenna alignment: refer to "Optimum mounting position", → 20.
- In devices with top target positioner, the sensor can be optimally aimed within the vessel, and/or interference reflections can be avoided.
The max. angle β is $\pm 15^\circ$.
- In particular, sensor alignment serves to:
 - prevent interference reflections
 - extend the maximum possible measuring range in conical outlets.
- Metallic screens (3) mounted at a slope spread the radar signals and can, therefore, reduce interference echoes.

Please contact Endress+Hauser for further information.

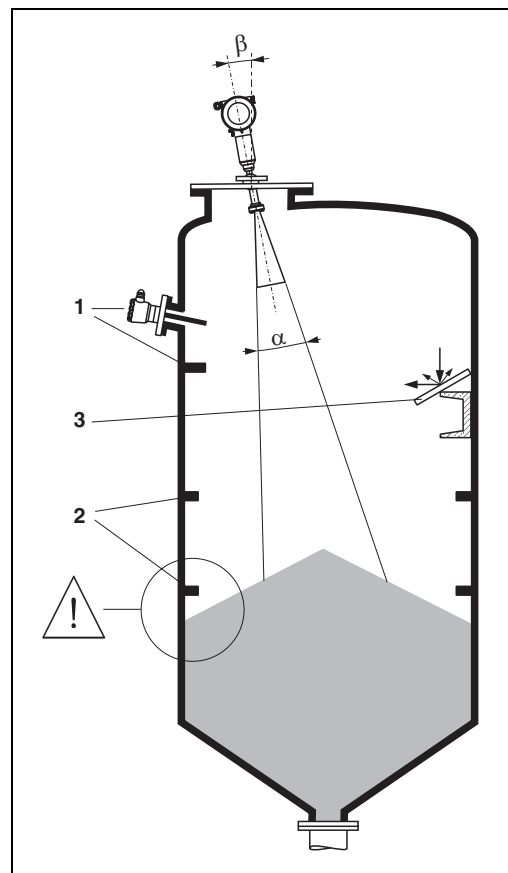

Measurement in a plastic tank

If the outer wall of the tank is made of a non-conductive material (e.g. GRP), microwaves can also be reflected off interfering installations outside the signal beam (e.g. metallic pipes (1), ladders (2), grates (3), ...). Therefore, there should be no such interfering installations in the signal beam.

Please contact Endress+Hauser for further information.

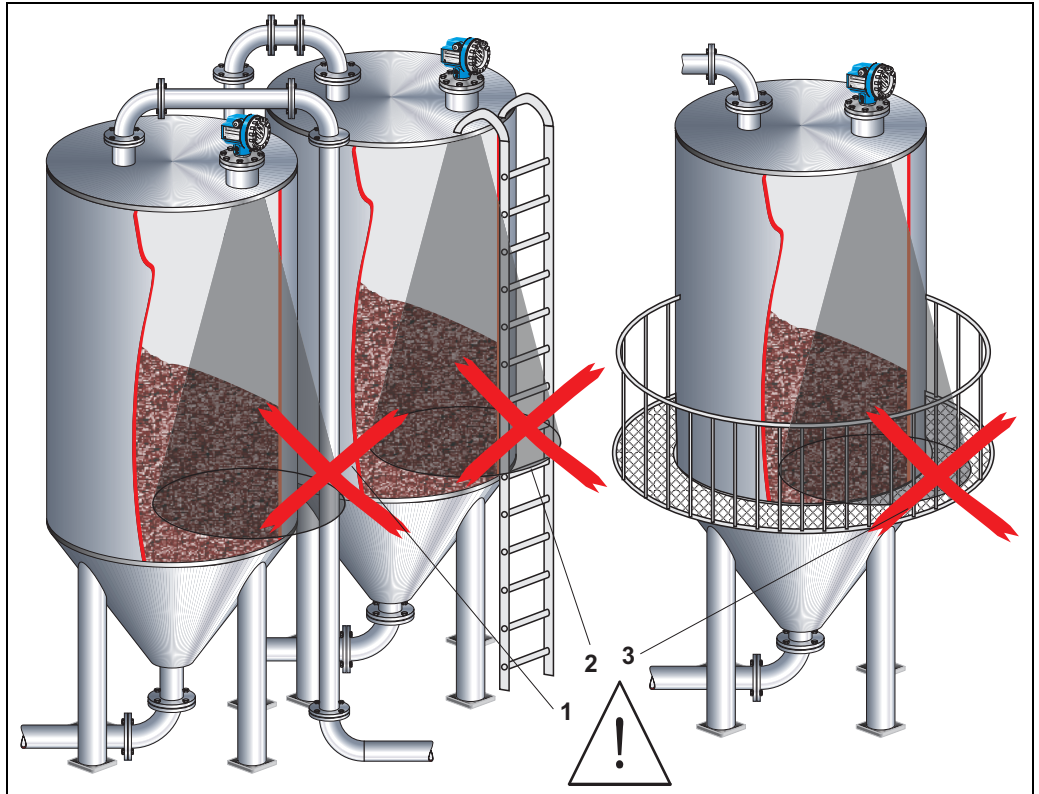

L00-FMR250xx-17-00-00-xx-014

Beam angle

The beam angle is defined as the angle α where the energy density of the radar waves reaches half the value of the maximum energy density (3dB-width). Microwaves are also emitted outside the signal beam and can be reflected off interfering installations. Beam diameter **W** as function of antenna type (beam angle α) and measuring distance **D**:

Antenna size	Horn antenna		Parabolic antenna	
	80 mm (3")	100 mm (4")	200 mm (8")	250 mm (10")
Beam angle α	10°	8°	4°	3.5°

Measuring distance (D)	Beamwidth diameter (W)			
	80 mm (3")	100 mm (4")	200 mm (8")	250 mm (10")
5 m (16 ft)	0,87 m (2.9 ft)	0,70 m (2.3 ft)	0,35 m (1.1 ft)	0,3 m (1 ft)
10 m (33 ft)	1,75 m (5.7 ft)	1,40 m (4.6 ft)	0,70 m (2.3 ft)	0,61 m (2 ft)
15 m (49 ft)	2,62 m (8.6 ft)	2,10 m (6.9 ft)	1,05 m (3.4 ft)	0,92 m (3 ft)
20 m (66 ft)	3,50 m (11 ft)	2,80 m (9.2 ft)	1,40 m (4.6 ft)	1,22 m (4 ft)
30 m (98 ft)	5,25 m (17 ft)	4,20 m (14 ft)	2,10 m (6.9 ft)	1,83 m (6 ft)
40 m (131 ft)	7,00 m (23 ft)	5,59 m (18 ft)	2,79 m (9.2 ft)	2,44 m (8 ft)
50 m (164 ft)	8,75 m (29 ft)	6,99 m (23 ft)	3,50 m (11 ft)	3,06 m (10 ft)

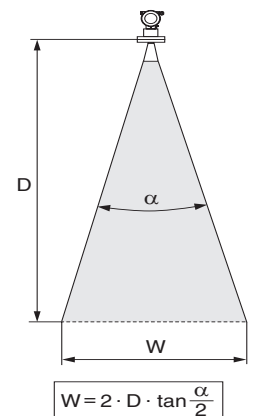

L00-FMR2xxxx-14-00-06-de-027

Installation in vessel FMR250 Optimum mounting position

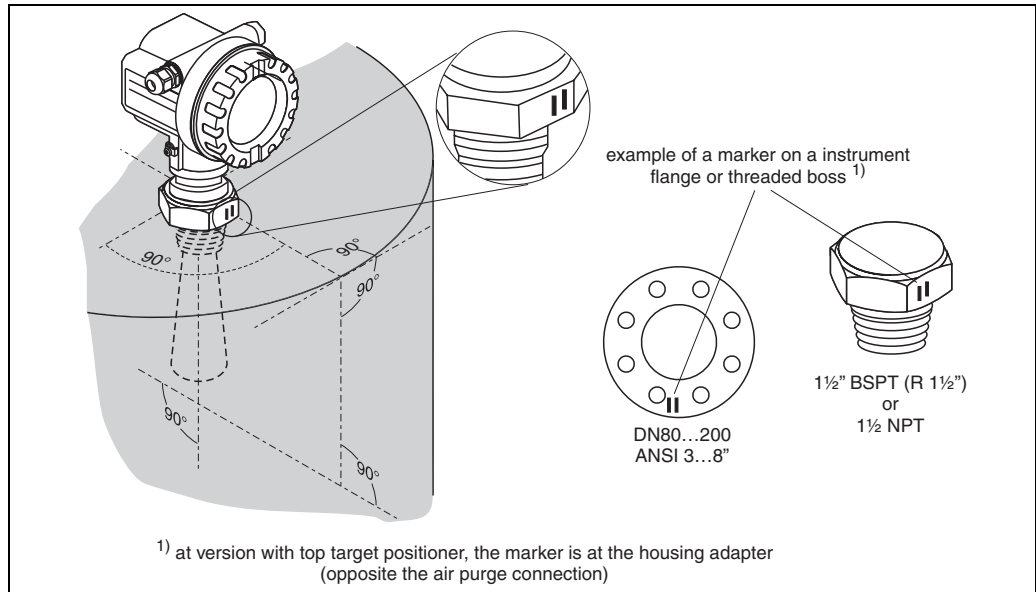

L00-FMR250xx-17-00-00-en-004

Standard installation FMR250 with horn antenna

- Observe installation instructions, → 18.
- Marker is aligned towards vessel wall.
The marker is good visibly situated between the sensor neck and the bolt-holes of the flange.
- After mounting, the housing can be turned 350° in order to simplify access to the display and the terminal compartment.
- The horn antenna should protrude from the nozzle. If this is not possible for mechanical reasons, larger nozzle heights can be accepted.
Note!
Please contact Endress+Hauser for application with higher nozzle.
- **Vertical horn antenna.**
Ideally, the horn antenna should be installed vertically. To avoid interference reflections or for optimum alignment within the vessel, the FMR250 with optional top target positioner can be swiveled by 15° in all directions.

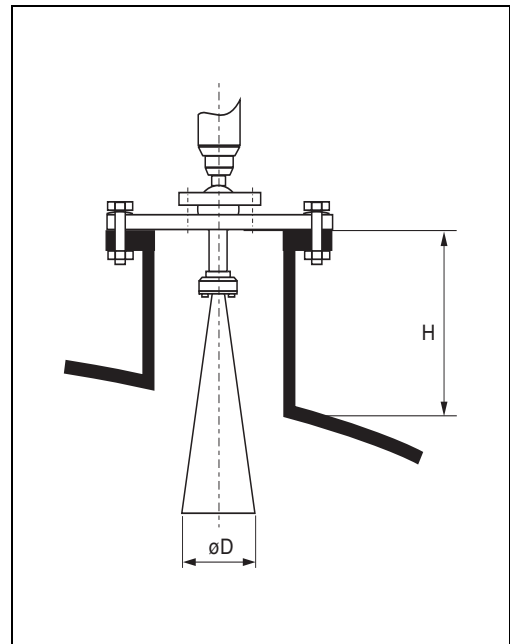

L00-FMR250xx-17-00-00-en-004

Antenna size	80 mm (3")	100 mm (4")
D [mm (in)]	75 (2.95)	95 (3.74)
H [mm (in)] (without antenna extension)	< 260 (< 10.2)	< 480 (< 18.9)

Standard installation FMR250 with parabolic antenna

- Observe installation instructions, → 18.
- Marker is aligned towards vessel wall.
The marker is good visibly situated between the sensor neck and the bold-holes of the flange.
- After mounting, the housing can be turned 350° in order to simplify access to the display and the terminal compartment.
- Ideally the parabolic antenna should protrude from the nozzle (1).
Particularly when using the top target positioner, please ensure that the parabolic reflector is protruding from the nozzle/roof so as not to inhibit alignment.

Note!

For applications with higher nozzle it may be necessary to install the parabolic antenna completely in the nozzle (2). The maximum height of the nozzle (H_{max}) to the parabolic mirror (option "G, H") should not exceed 500 mm (19.7 in). Interfering edges within the nozzle should be avoided.

■ **Vertical parabolic antenna.**

Ideally, the parabolic antenna should be installed vertically.

To avoid interference reflections or for optimum alignment within the vessel, the FMR250 with optional top target positioner can be swiveled by 15° in all directions.

Parabolic antenna	Option "G"	Option "H"
Antenna size	200 mm (8")	250 mm (10")
D [mm (in)]	173 (6.81)	236 (9.29)
H [mm (in)] (without antenna extension)	< 50 (< 1.96)	< 50 (< 1.96)

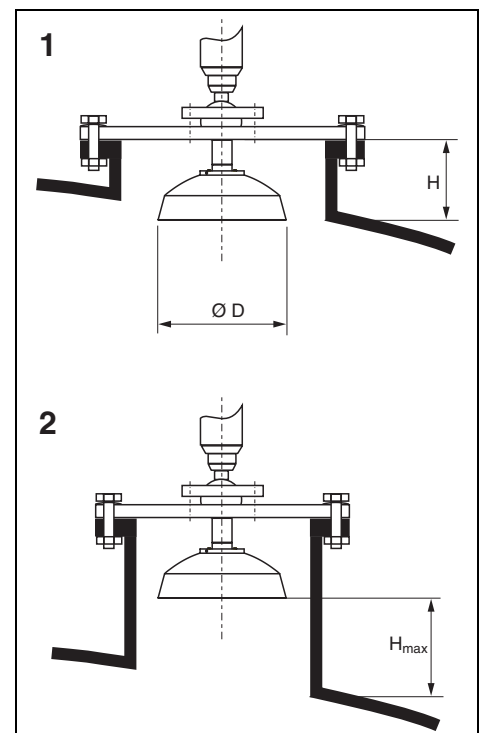

L00-FMR250xx-17-00-00-en-004

Examples for installation with small flange (< parabolic reflector)
for parabolic antenna (option "G, H")

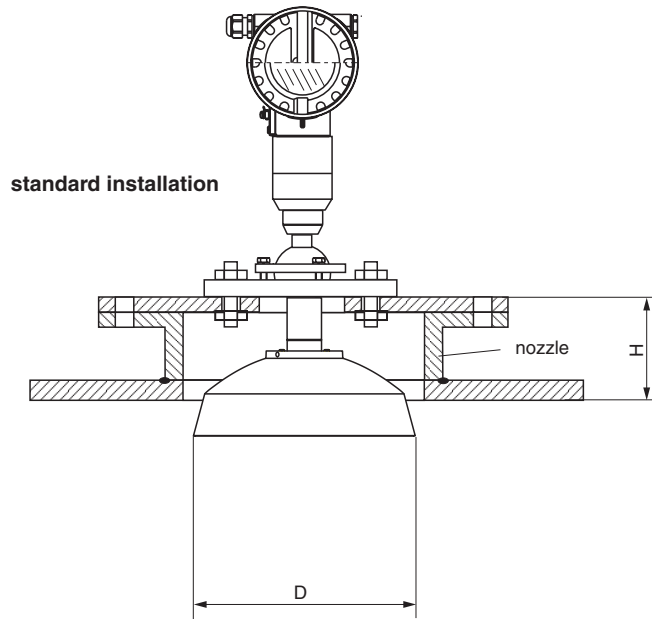

Antenna size	200 mm (8")	250 mm (10")
D [mm (inch)]	173 (6.81)	236 (9.29)
H [mm (inch)] ¹⁾	< 50 (< 1.96)	< 50 (< 1.96)

¹⁾ without antenna extension

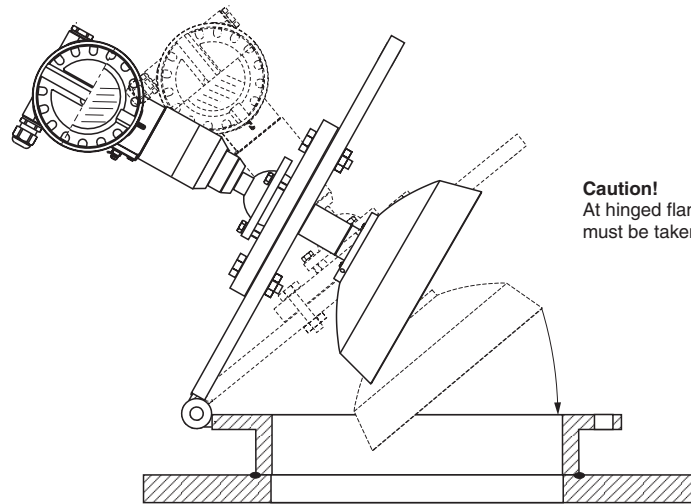
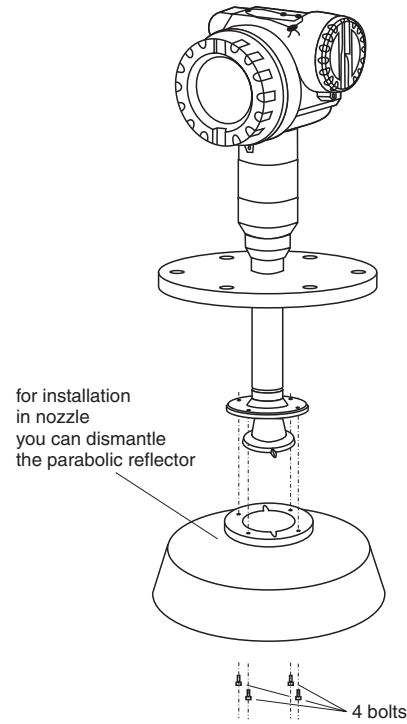

Caution!
At hinged flanges, the length of the antenna must be taken into account!

s0011471-en

FMR250 with top target positioner

Optimum mounting position

Using top target positioner it is possible to tilt the antenna axis by up to 15° in all directions. The top target positioner is used for the optimum alignment of the radar beam with the bulk solids surface.

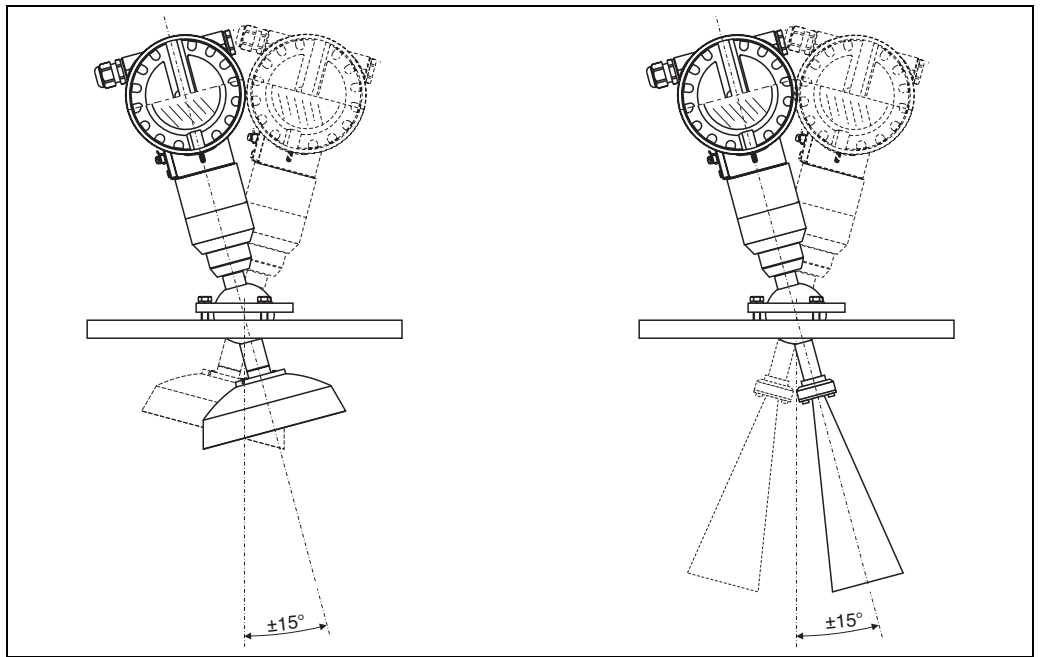

80011472

Align antenna axis:

1. Loosen screws.
2. Align antenna axis (here this is possible up to max. ±15° in all directions).
3. Tighten screws.

Integrated air purge connection

In extremely dusty applications, the integrated air purge connection can prevent clogging of the antenna. Pulsed operation is recommended.

- Pulsed operation:
max. pressure of purge air: 6 bar abs (87 psi).
- Permanent operation:
recommended pressure range of the purge air:
200 mbar to 500 mbar (3 psi to 7.25 psi).

Caution!

Make sure to use dry purge air.

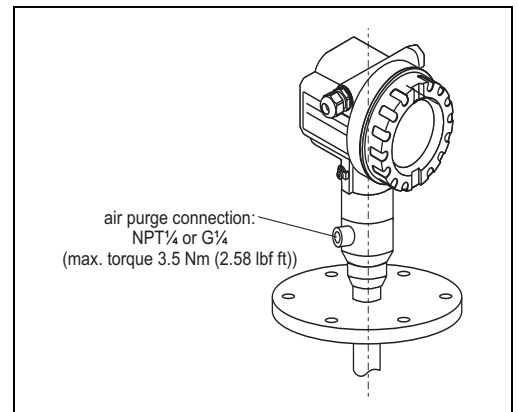

L00-FMR250xx-17-00-00-en-010

Operating conditions: Environment

Ambient temperature range	Ambient temperature for the transmitter: -40 °C to +80 °C (-40 °F to +176 °F) or -50 °C to +80 °C (-58 °F to +176 °F) on request. The functionality of the LCD display may be limited for temperatures $T_a < -20$ °C (-4 °F) and $T_a > +60$ °C (+140 °F). A weather protection cover should be used for outdoor operation if the instrument is exposed to direct sunlight.
Storage temperature	-40 °C to +80 °C (-40 °F to +176 °F) or -50 °C to +80 °C (-58 °F to +176 °F).
Climate class	DIN EN 60068-2-38 (test Z/AD)
Degree of protection	<ul style="list-style-type: none"> ■ housing: IP 65, NEMA 4X (open housing and pulled out display: IP20, NEMA1) ■ antenna: IP 68 (NEMA 6P)
Vibration resistance	DIN EN 60068-2-64 / IEC 68-2-64: 20...2000 Hz, 1 (m/s ²) ² /Hz
Cleaning of the antenna	<p>The antenna can get contaminated, depending on the application. The emission and reception of microwaves can thus eventually be hindered. The degree of contamination leading to an error depends on the medium and the reflectivity, mainly determined by the dielectric constant ϵ_r. If the medium tends to cause contamination and deposits, cleaning on a regular basis is recommended. Care has to be taken not to damage the antenna in the process of a mechanical or hose-down cleaning (eventually air purge connection). The material compatibility has to be considered if cleaning agents are used!</p> <p>The maximum permitted temperature at the flange should not be exceeded.</p>
Electromagnetic compatibility	<ul style="list-style-type: none"> ■ Electromagnetic compatibility in accordance with all the relevant requirements of the EN61326 series and NAMUR recommendation (NE21). For details refer to the Declaration of Conformity. Maximum deviation < 0.5 % of the span. ■ A standard installation cable is sufficient if only the analogue signal is used. Use a screened cable when working with a superimposed communications signal (HART).

Operating conditions: Process

Process temperature range / Process pressure limits

Note!

The specified range may be reduced by the selected process connection. The pressure rating (PN) specified on the nameplate refers to a reference temperature of 20 °C (68 °F), for ASME flanges to 100 °F. Observe pressure-temperature dependency.

The pressure values permitted at higher temperatures can be found in the following standards:

- EN 1092-1: 2001 Tab. 18

With regard to their temperature stability properties, the materials 1.4404 and 1.4435 are grouped under 13E0 in EN 1092-1 Tab. 18. The chemical composition of the two materials can be identical.

- ASME B 16.5a - 1998 Tab. 2-2.2 F316
- ASME B 16.5a - 1998 Tab. 2.3.8 N10276
- JIS B 2220

Feature "20 Antenna:"			Seal	Temperature	Pressure ¹⁾	Wetted parts
Type	Option	Size				
Horn	4	80 mm (3")	FKM Viton	-40 °C to +200 °C (-40 °F to +392 °F)	-1 bar to 16 bar (-14.5 psi to 232 psi)	PEEK, seal, 316L/1.4404/1.4435
	5	100 mm (4")	GLT			
	D	80 mm (3")				
	E	100 mm (4")				
Parabolic	G	200 mm (8")	FKM Viton	-40 °C to +200 °C (-40 °F to +392 °F)	-1 bar to 16 bar (-14.5 psi to 232 psi)	PTFE, seal, 316L/1.4404/1.4435
	H	250 mm (10")	GLT			

↑

Ordering information, →  41

1) Endress+Hauser UNI flange: -1 bar to 1 bar (-14.5 psi to 14.5 psi)

Optional top target positioner: ±15°, seal: FMK Viton GLT

Dielectric constant

In free space: $\epsilon_r \geq 1.6$ (for horizontal, even product surfaces: $\epsilon_r \geq 1.4$)

Mechanical construction

Design, dimensions

Housing dimensions

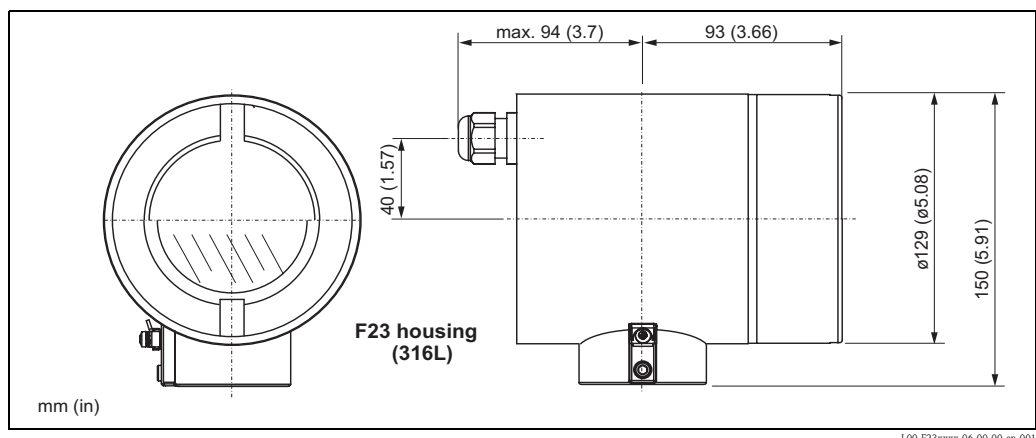
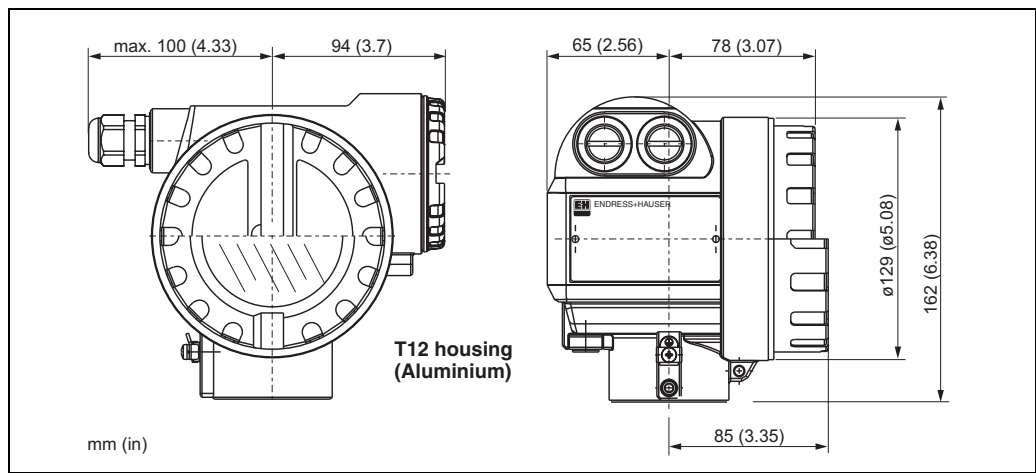
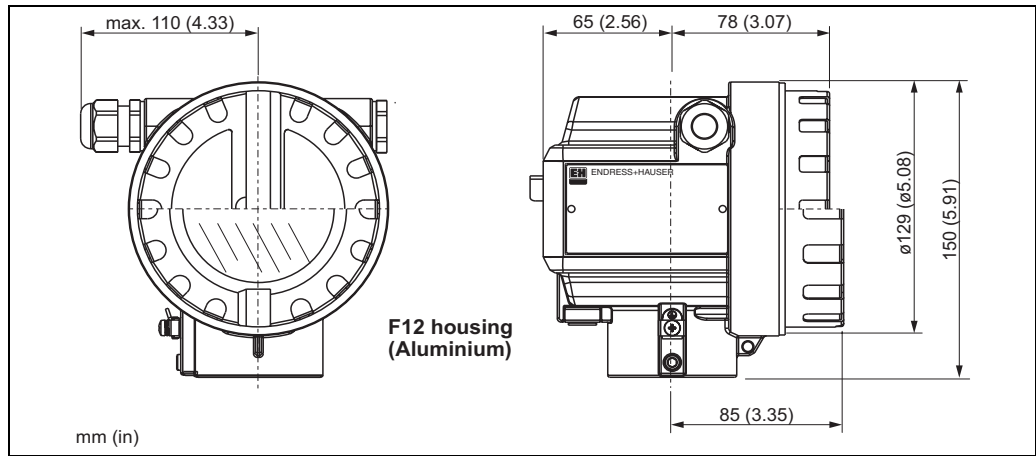

Process connection and antenna (option "4, 5")

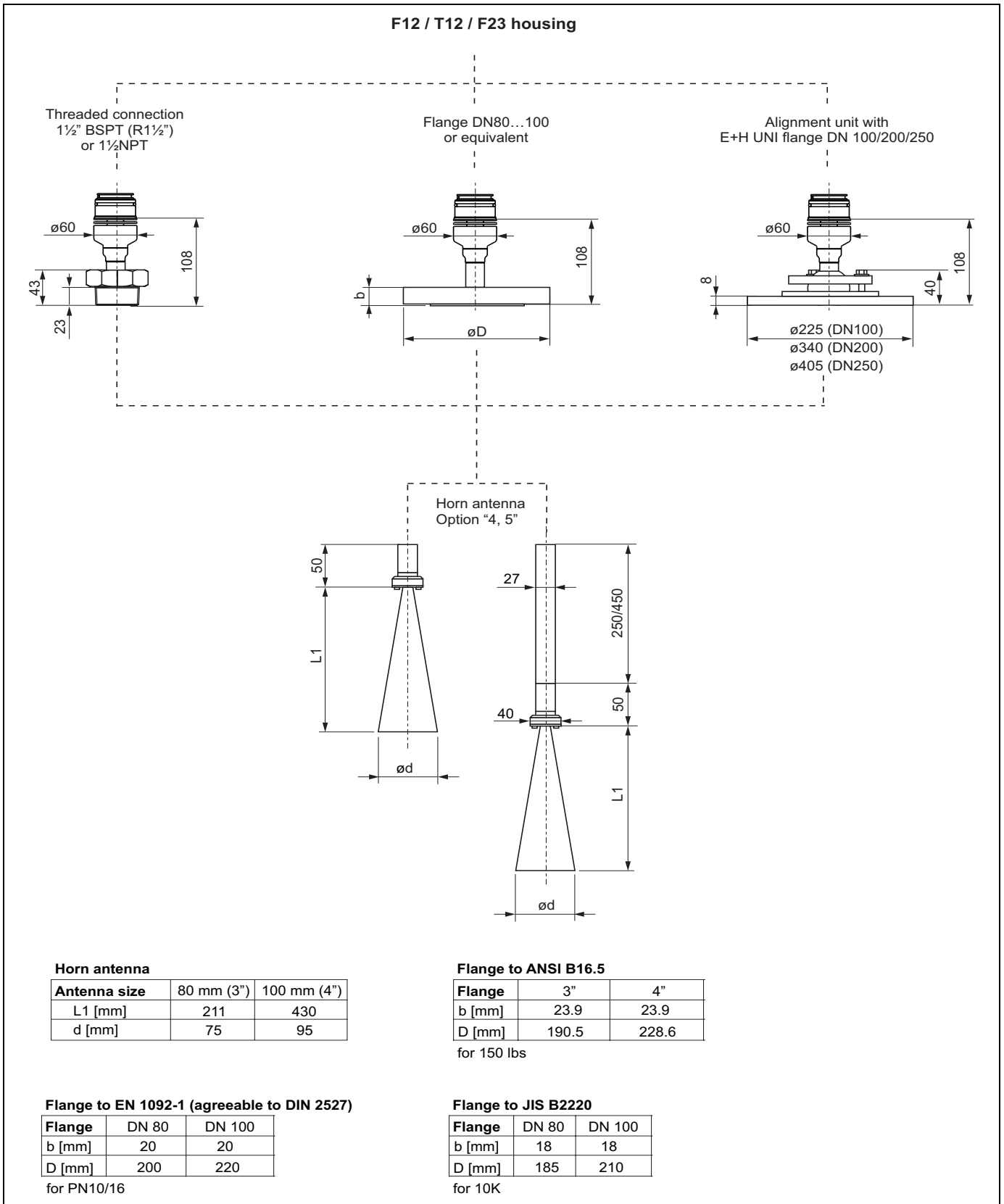

a0011475-en

Process connection and antenna (option "D, E, G, H")

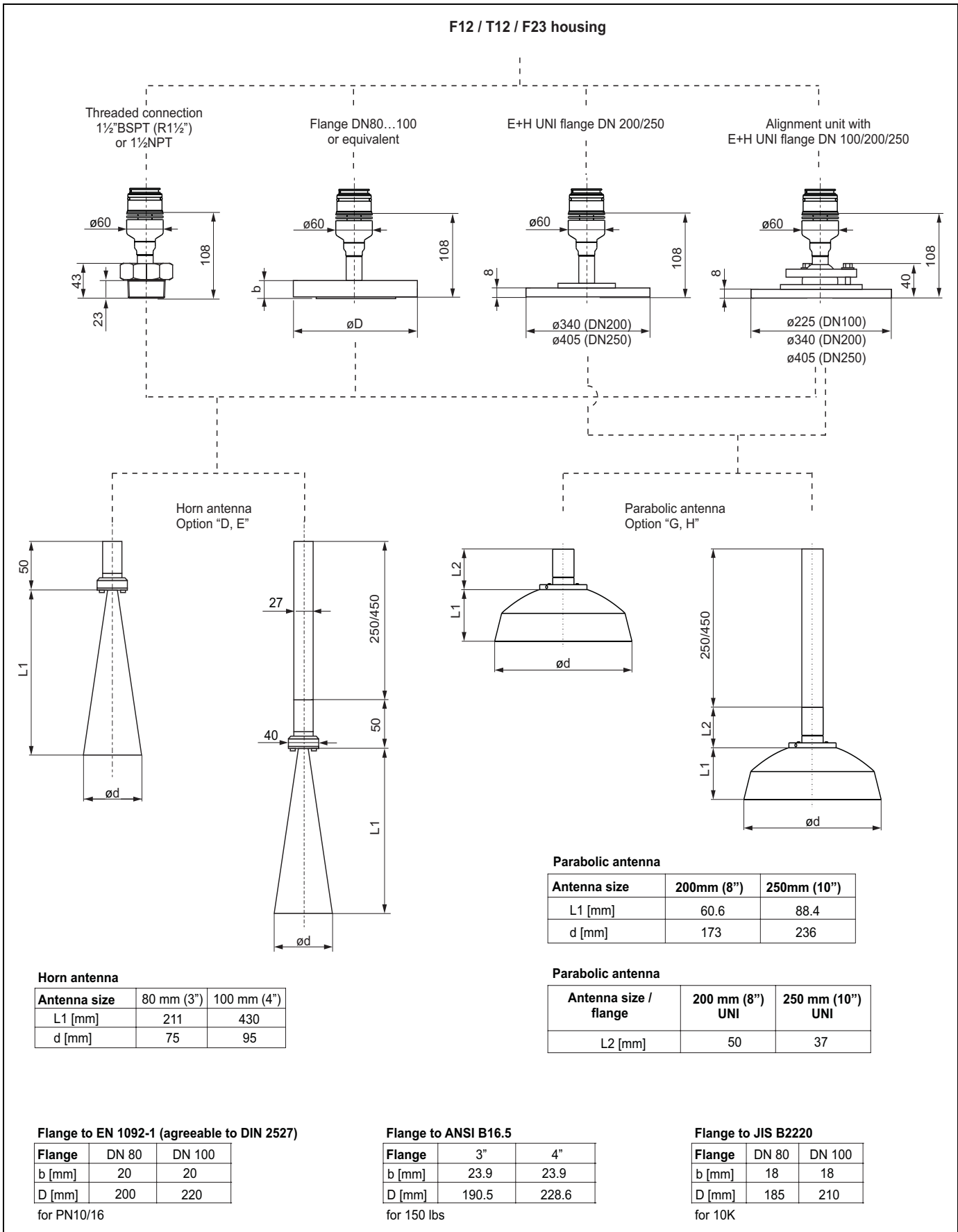

Endress+Hauser UNI flange Installation hints

The number of bolts has sometimes been reduced. The bolt-holes have been enlarged for adaption of dimensions, therefore, the flange needs to be properly aligned to the counterflange before the bolts are tightened.

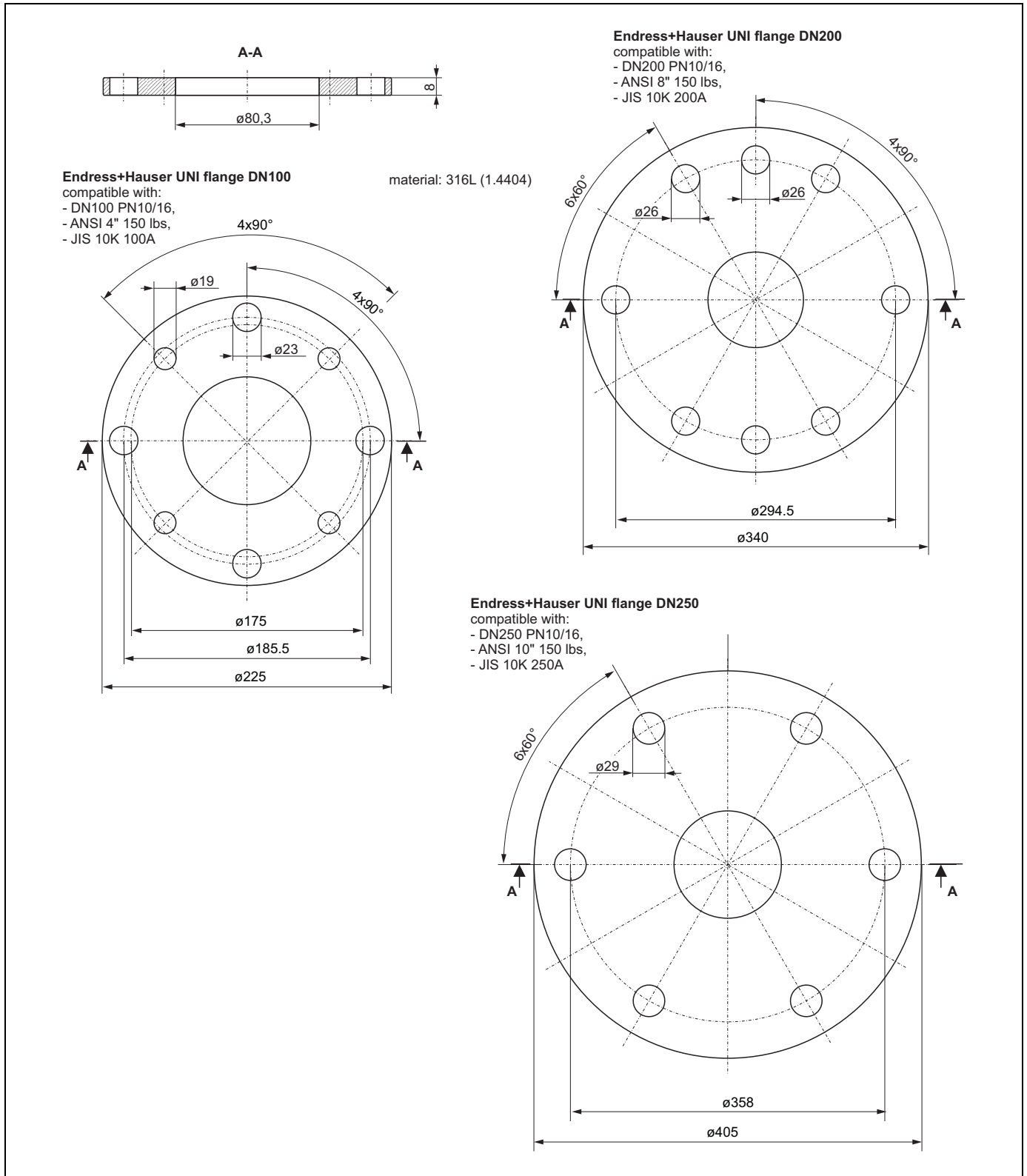

a0011480-en

Top target positioner with Endress+Hauser UNI flange

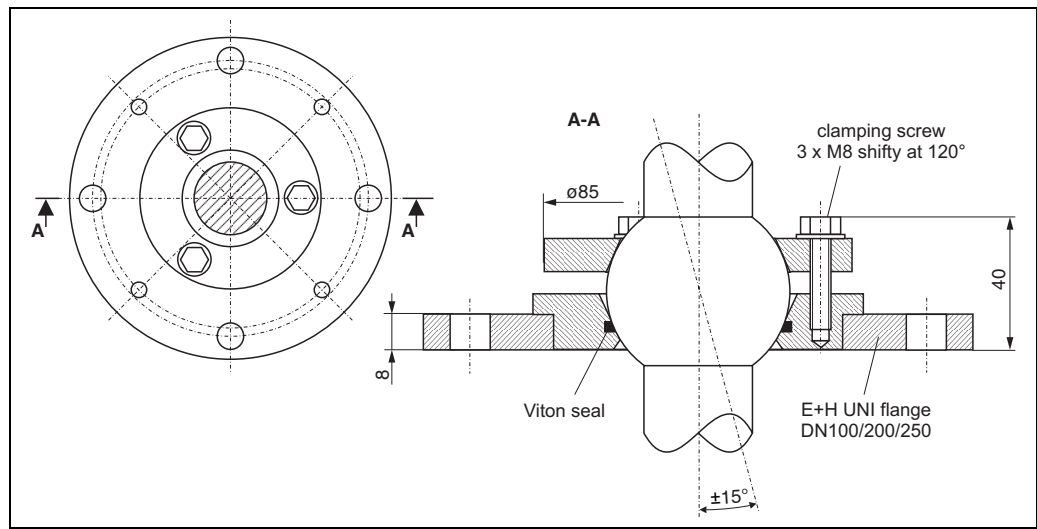

a0011477-en

Weight

Micropilot M	FMR250
Weight for F12 or T12 housing	Approx. 6 kg (13.32 lbs) + weight of flange
Weight for F23 housing	Approx. 9.4 kg (20.73 lbs) + weight of flange

**Material
(not in contact with process)**

Materials of T12 and F12 housing (seawater-resistant*, powder-coated)

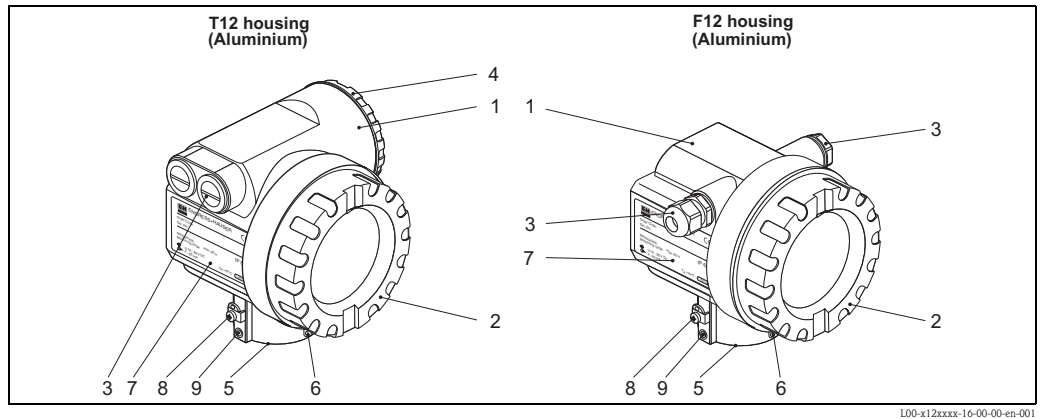

L00-x12xxxx-16-00-00-en-001

Pos.	Part	Material	
1	T12 and F12 housing	AlSi10Mg	
2	Cover (Display)	AlSi10Mg	
	Sealing	Fa. SHS: EPDM 70pW FKN	
	Window	ESG-K-Glass (Toughened safety glass)	
	Sealing of the glass	Silicone sealing compound Gomastit 402	
3	Sealing	Fa. SHS: EPDM 70 pW FKN	Trelleborg: EPDM E7502
	Cable gland	Polyamid (PA), CuZn nickel-plated	
	Plug	PBT-GF30	1.0718 galvanized
		PE	3.1655
Adapter	316L (1.4435)	AlMgSiPb (anodized)	
4	Cover (Connection compartment)	AlSi10Mg	
	Sealing	Fa. SHS: EPDM 70pW FKN	Trelleborg: EPDM E7502/E7515
	Clamp	Screws: A4; Clamp: Ms nickel-plated; Spring washer: A4	
5	Sealing ring	Fa. SHS: EPDM 70pW FKN	Trelleborg: EPDM E7502/E7515
6	Tag	304 (1.4301)	
	Rope	VA	
	Crimp sleeve	Aluminium	
7	Nameplate*	304 (1.4301)	
	Groove pin*	A2	
8	Ground terminal*	Screws: A2; Spring washer: A4; Clamp: 304 (1.4301) Holder: 301 (1.4310)	
9	Screws*	A2-70	

* Seawater-resistant on request (complete in 316L (1.4404)).

Materials of F23 housing (seawater-resistant*, corrosion-resistant)

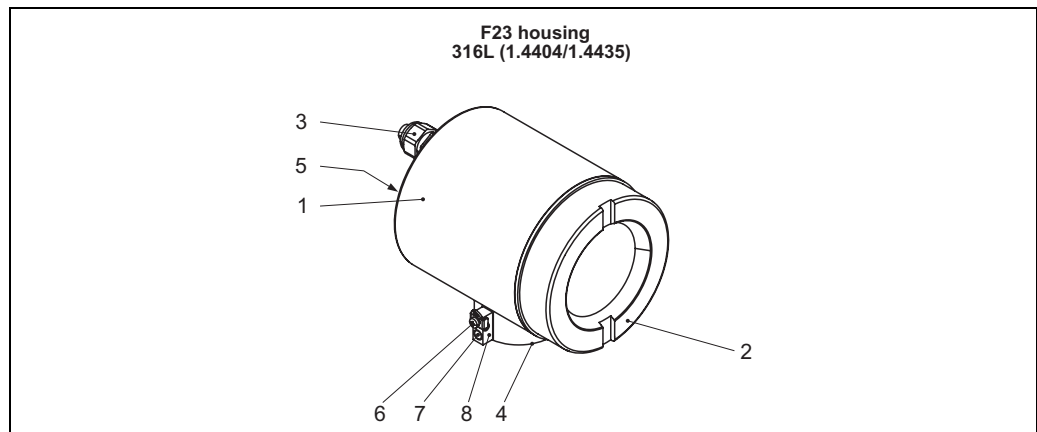

L00-x12xxxx-16-00-00-en-001

Pos.	Part	Material	
1	F23 housing	Housing body: 316L (1.4404); Sensor neck: 316L (1.4435); earth connection block: 316L (1.4435)	
2	Cover	316L (1.4404)	
	Sealing	Fa. SHS: EPDM 70pW FKN	
	Window	ESG-K-Glass (Toughened safety glass)	
	Sealing of the glass	Silicone sealing compound Gomastit 402	
3	Sealing	Fa. SHS: EPDM 70pW FKN	Trelleborg: EPDM E7502
	Cable gland	Polyamid (PA), CuZn nickel-plated	
	Plug	PBT-GF30	1.0718 galvanized
		PE	3.1655
Adapter	316L (1.4435)		
4	Sealing ring	Fa. SHS: EPDM 70pW FKN	Trelleborg: EPDM E7502
5	Nameplate*	304 (1.4301)	
	Groove pin*	A2	
6	Grounding terminal*	Screws: A2; Spring washer: A4; Clamp: 304 (1.4301); Holder: 301 (1.4310)	
7	Screw*	A2-70	
8	Tag	304 (1.4301)	
	Rope	316 (1.4401)	
	Crimp sleeve	Aluminium	

* Seawater-resistant on request (complete in 316L (1.4404)).

Material
(in contact with process)

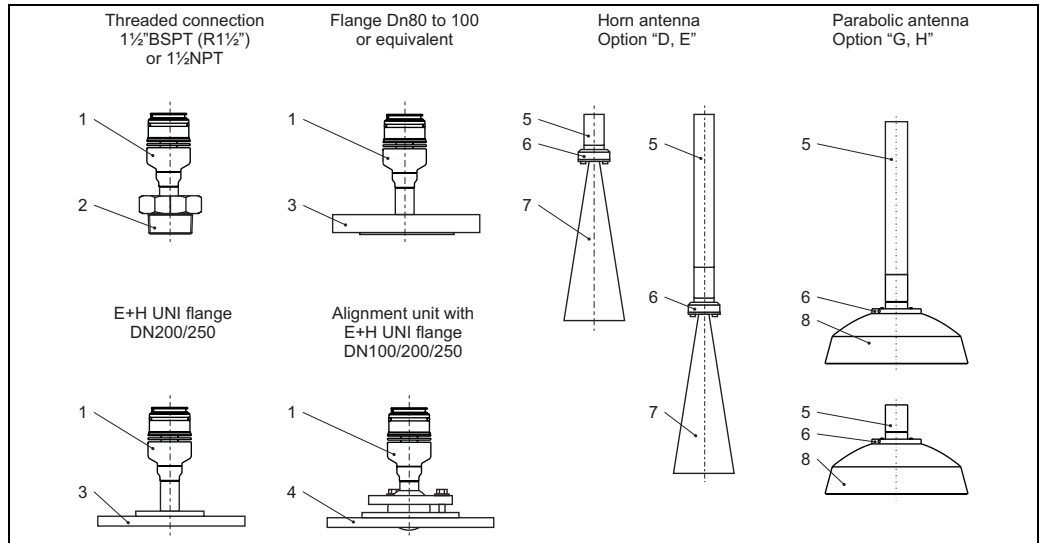

L00-FMR250xx-16-00-00-en-001

Pos.	Part	Material
1	Adapter	316L (1.4404)
	Plug	A4
	Adapter (G → NPT)	316L (1.4404)
	Sealing	Viton
2	Process connection	R1½": 316L (1.4404) 1½" NPT: 316L (1.4404/1.4435)
3	Flange	316L (1.4404 / 1.4435)
	Adapter	316L (1.4404)
4	Flange	316L (1.4404)
	Ball	316L (1.4404)
	Screws	A2
	Spring washer	1.4310
	Jammes flange	316L (1.4404)
	Adapter	316L (1.4404)
5	Pipe	316L (1.4404)
	Parts for process separation	316L (1.4404)
6	Adapter Horn/Parabolic	316L (1.4404)
	Horn	316L (1.4404)
7	Screws	A4
	Parabolic reflector	316L (1.4404)
8	Screws	A4

Flange

Endress+Hauser supplies DIN/EN flanges made of stainless steel according to AISI 316L (DIN/EN material number 1.4404 or 1.4435). With regard to their temperature stability properties, the materials 1.4404 and 1.4435 are grouped under 13E0 in EN1092-1 Tab. 18. The chemical composition of the two materials can be identical.

Process connection See "Ordering information", → 41 ff.

Seal See "Ordering information", → 41 ff.

Antenna See "Ordering information", → 41 ff.

Human interface

Operation concept

The display of the process value and the configuration of the Micropilot occur locally by means of a large 4-line alphanumeric display with plain text information. The guided menu system with integrated help texts ensures a quick and safe commissioning. To access the display the cover of the electronic compartment may be removed even in hazardous area (IS and XP).

Remote commissioning, including documentation of the measuring point and in-depth analysis functions, is supported via the FieldCare, the graphical operating software for Endress+Hauser time-of-flight systems.

Display elements

Liquid crystal display (LCD):

Four lines with 20 characters each. Display contrast adjustable through key combination.

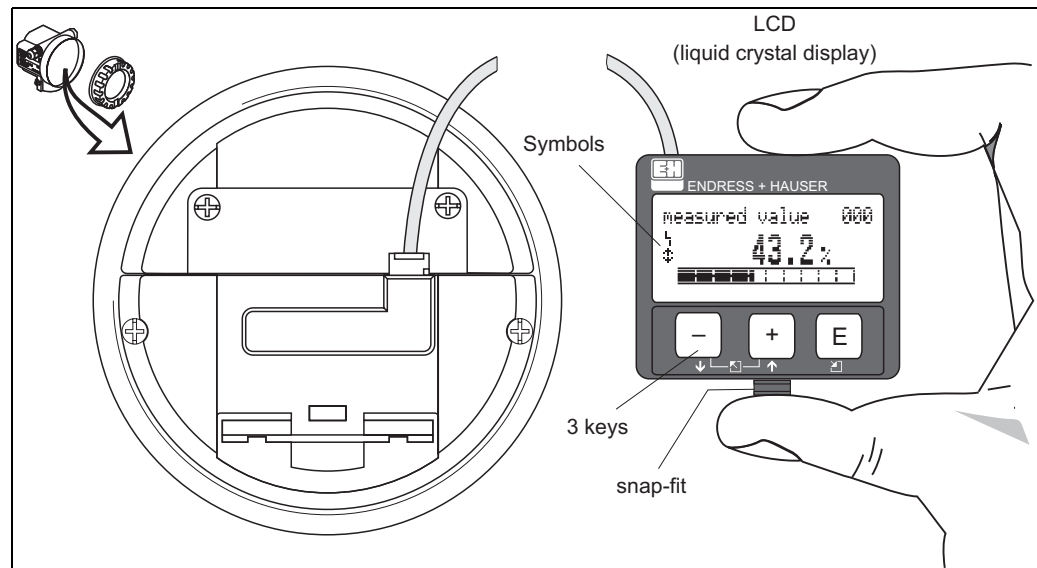

L00-FMxxxxx-07-00-00-en-001

The LCD display can be removed to ease operation by simply pressing the snap-fit (see graphic above). It is connected to the device by means of a 500 mm (19.7 in) cable.















The following table describes the symbols that appear on the liquid crystal display:

Sybmol	Meaning
	ALARM_SYMBOL This alarm symbol appears when the instrument is in an alarm state. If the symbol flashes, this indicates a warning.
	LOCK_SYMBOL This lock symbol appears when the instrument is locked, i.e. if no input is possible.
	COM_SYMBOL This communication symbol appears when a data transmission via e.g. HART, PROFIBUS PA or FOUNDATION Fieldbus is in progress.
	SIMULATION_SWITCH_ENABLE This communication symbol appears when simulation in FOUNDATION Fieldbus is enabled via the DIP switch.

Operating elements

The operating elements are located inside the housing and are accessible for operation by opening the lid of the housing.

Function of the keys

Key(s)	Meaning
 or 	Navigate upwards in the selection list. Edit numeric value within a function.
 or 	Navigate downwards in the selection list. Edit numeric value within a function.
  or 	Navigate to the left within a function group.
	Navigate to the right within a function group, confirmation.
 and  or  and 	Contrast settings of the LCD.
 and  and 	Hardware lock / unlock After a hardware lock, an operation of the instrument via display or communication is not possible! The hardware can only be unlocked via the display. An unlock parameter must be entered to do so.

On-site operation

Operation with device display

The LC-Display allows configuration via 3 keys directly at the instrument. All device functions can be set through a menu system. The menu consists of function groups and functions. Within a function, application parameters can be read or adjusted. The user is guided through a complete configuration procedure.

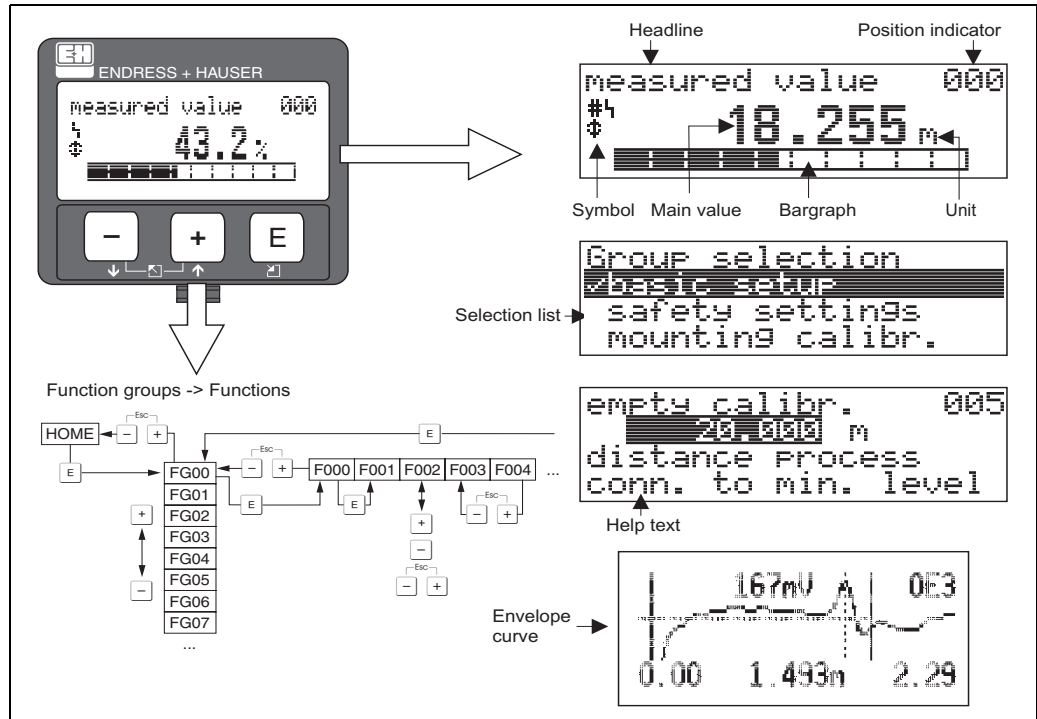

L00-FMRxxxxx-07-00-00-en-002

Operation with the Field Communicator 375, 475

All device functions can be adjusted via a menu operation with the Field Communicator 375, 475.

Note!

Further information on the handheld unit is given in the respective operating manual included in the transport bag of the Field Communicator 375, 475.

Remote operation

The MicroPilot M can be remotely operated via HART, PROFIBUS PA and FOUNDATION Fieldbus. On-site adjustments are also possible.

FieldCare

FieldCare is an Endress+Hauser asset management tool based on FDT technology. With FieldCare, you can configure all Endress+Hauser devices as well as devices from other manufacturers that support the FDT standard. Hardware and software requirements you can find on the internet: www.endress.com → select your country → search: FieldCare → FieldCare → Technical Data.

FieldCare supports the following functions:

- Configuration of transmitters in online operation
- Singal analysis via envelope curve
- Tank linearisation
- Loading and saving device data (upload/download)
- Documentation of the measuring point

Connection options:

- HART via Commubox FXA195 and the USB port on a computer
- PROFIBUS PA via segment coupler and PROFIBUS interface card
- Commubox FXA291 with ToF Adapter FXA291 (USB) via service interface

Menu-guided commissioning

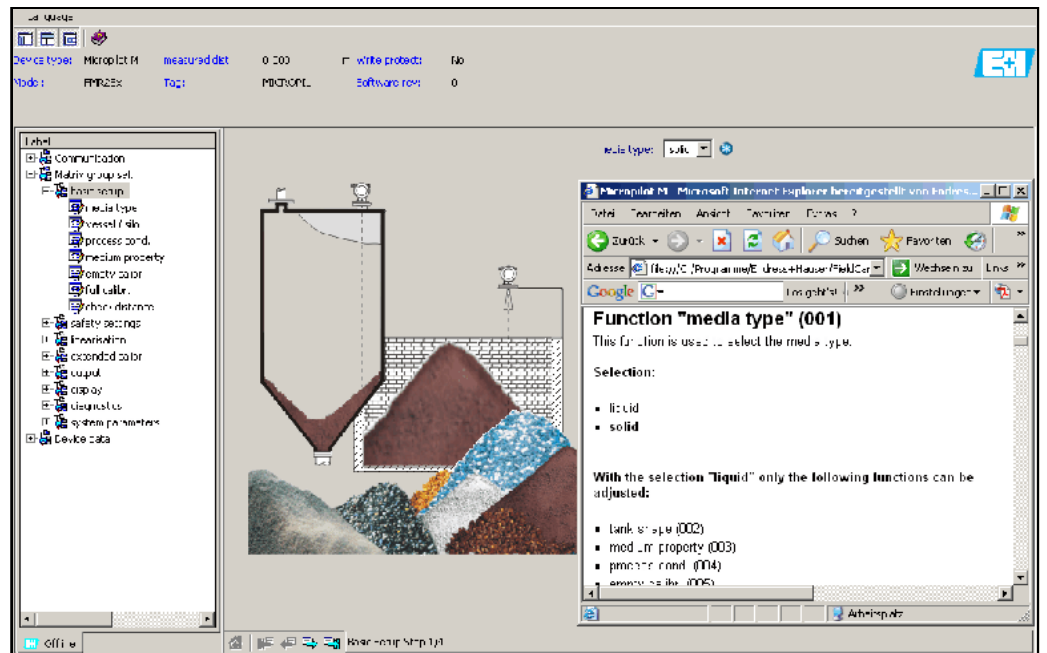

MicroPilotMen-415

Signal analysis via envelope curve

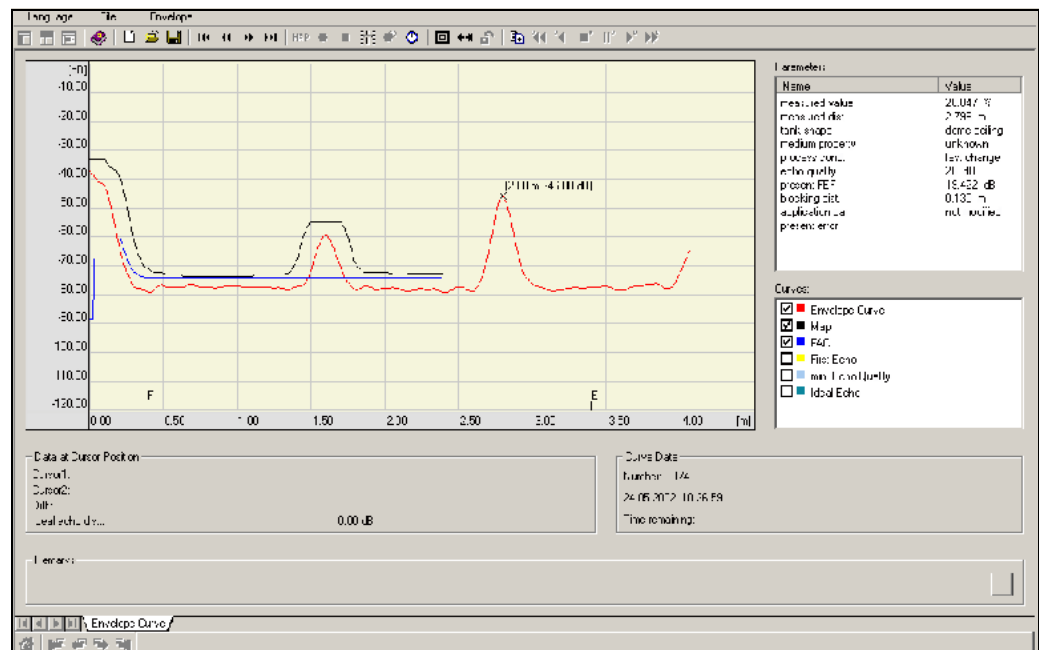

MicropilotM-en-410

Tank linearisation

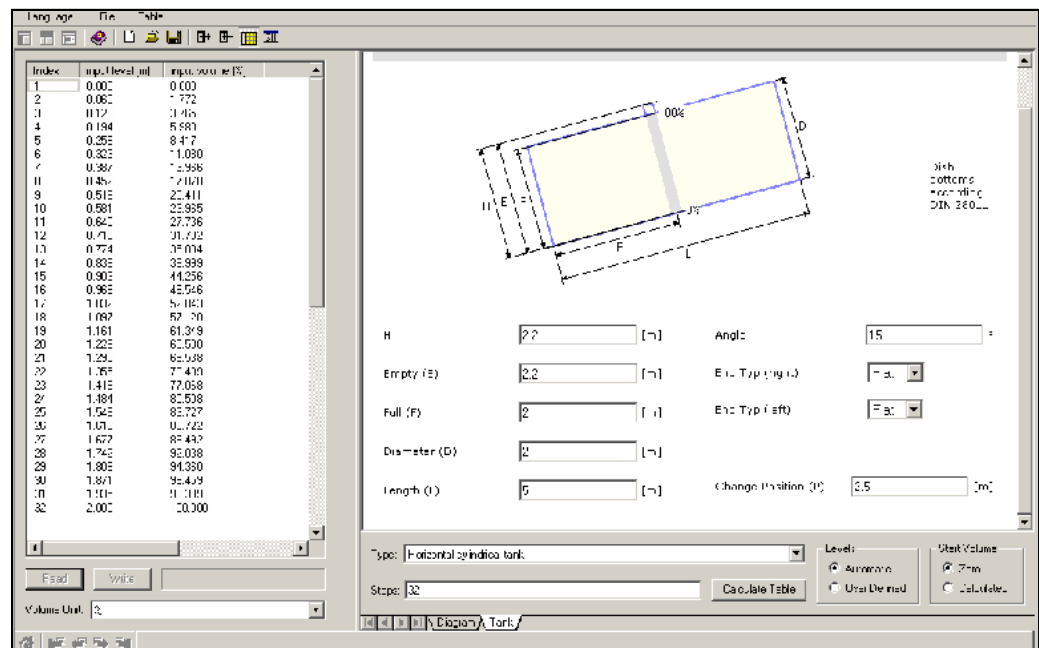

MicropilotM-en-417

Operation with NI-FBUS configurator (only FOUNDATION Fieldbus)

The NI-FBUS Configurator is an easy-to-use graphical environment for creating linkages, loops, and a schedule based on the fieldbus concepts.

You can use the NI-FBUS Configurator to configure a fieldbus network as follows:

- Set block and device tags
- Set device addresses
- Create and edit function block control strategies (function block applications)
- Configure vendor-defined function and transducer blocks
- Create and edit schedules
- Read and write to function block control strategies (function block applications)
- Invoke Device Description (DD) methods
- Display DD menus
- Download a configuration
- Verify a configuration and compare it to a saved configuration
- Monitor a downloaded configuration
- Replace devices
- Log project download changes
- Save and print a configuration

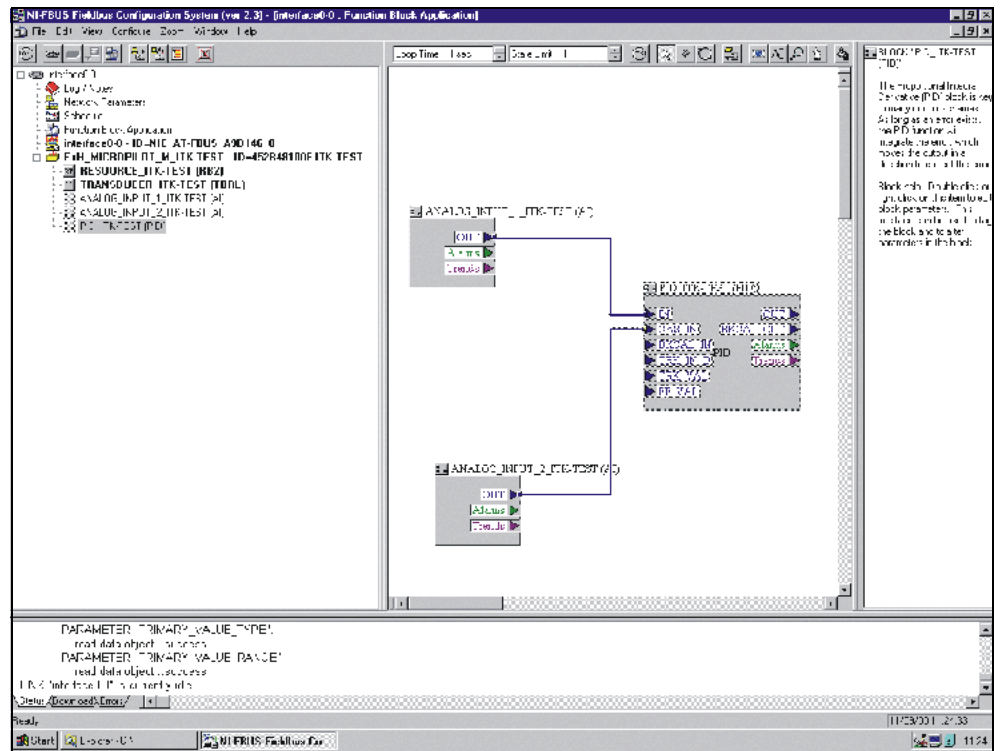

L00-fmxxxxx-20-00-00-en-001

Certificates and approvals

CE approval	The measuring system meets the legal requirements of the EC-guidelines. Endress+Hauser confirms the instrument passing the required tests by attaching the CE-mark.
Ex approval	See "Ordering information", → 41ff.
Overspill protection	SIL 2, for 4 to 20 mA output signal (see SD00327F/00/EN "Functional Safety Manual").
External standards and guidelines	<p>EN60529 Protection class of housing (IP-code).</p> <p>EN61010 Safety regulations for electrical devices for measurement, control, regulation and laboratory use.</p> <p>EN61326-X EMC product family standard for electrical equipment for measurement, control and laboratory use.</p> <p>NAMUR User Association for Automation in Process Industries.</p>
RF approvals	R&TTE, FCC

Ordering information

Micropilot M FMR250

Instrument selection

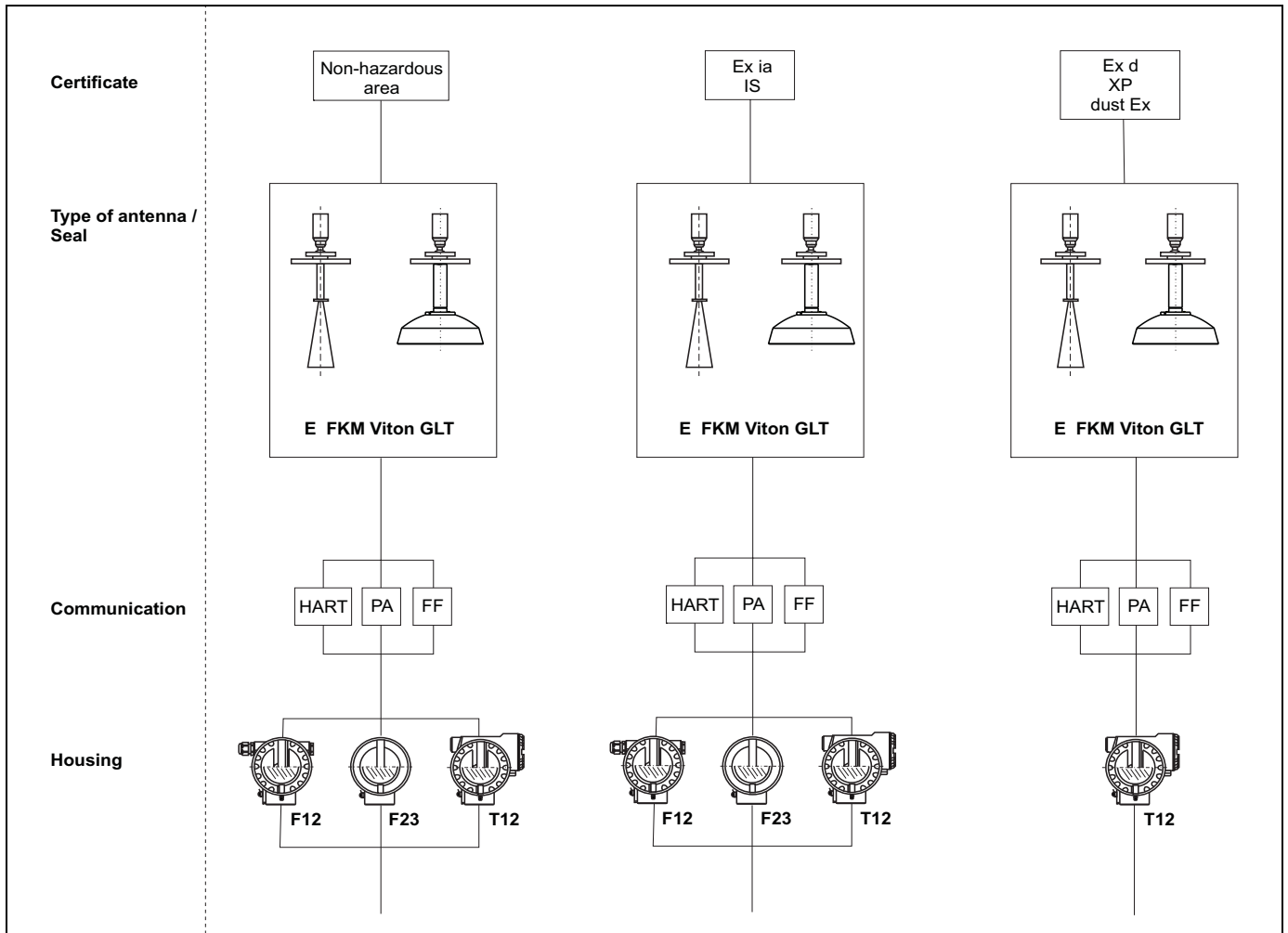

a0011489-es

Ordering structure Micropilot M FMR250

10	Approval:		
	A	Non-hazardous area	
	1	ATEX II 1/2G EEx ia IIC T6	
	4	ATEX II 1/2G EEx d [ia] IIC T6	
	G	ATEX II 3G EEx nA II T6	
	B	ATEX II 1/2GD EEx ia IIC T6, Alu blind cover	
	C	ATEX II 1/2G EEx ia IIC T6, ATEX II 1/3D	
	D	ATEX II 1/2D, Alu blind cover	
	E	ATEX II 1/3D	
	I	NEPSI Ex ia IIC T6	
	J	NEPSI Ex d (ia) ia IIC T6	
	Q	NEPSI DIP	
	L	TISS EEx d (ia) IIC T3	
	S	FM IS-Cl.I/II/III Div.1 Gr.A-G, zone 0, 1, 2	
	T	FM XP-Cl.I/II/III Div.1 Gr.A-G, zone 1, 2	
	N	CSA General Purpose	
	U	CSA IS Cl.I/II/III Div.1 Gr.A-G, zone 0, 1, 2	
	V	CSA XP Cl.I/II/III Div.1 Gr.A-G, zone 1, 2	
	Y	Special version, TSP-No. to be spec.	
20	Antenna:		
	D	Horn 80mm/3", increased near distance dynamics	
	E	Horn 100mm/4", increased near distance dynamics	
	G	Parabolic 200mm/8", increased near distance dynamics	
	H	Parabolic 250mm/10", increased near distance dynamics	
	9	Special version, TSP-No. to be spec.	
30	Antenna seal; Temperature:		
	E	FKM Viton GLT; -40...200°C/-40...392 °F	
	Y	Special version, TSP-No. to be spec.	
40	Antenna extension:		
	1	Not selected	
	2	250mm/10"	
	3	450mm/18"	
	9	Special version, TSP-No. to be spec.	
50	Process connection:		
	GGJ	Thread EN10226 R1-1/2, 316L	
	GNJ	Thread ANSI NPT1-1/2, 316L	
	X3J	UNI flange DN200/8"/200, 316L max PN1/14.5lbs/1K, compatible DN200 PN10/16, 8" 150lbs, 10K 200	
	X5J	UNI flange DN250/10"/250, 316L max PN1/14.5lbs/1K, compatible DN250 PN10/16, 10" 150lbs, 10K 250	
	XCJ	Top target pos., UNI DN100/4"/100, 316L max PN1/14.5lbs/1K, compatible DN100 PN10/16, 4" 150lbs, 10K 100	
	XEJ	Top target pos., UNI DN200/8"/200, 316L max PN1/14.5lbs/1K, compatible DN200 PN10/16, 8" 150lbs, 10K 200	
	XFJ	Top target pos., UNI DN250/10"/250, 316L max PN1/14.5lbs/1K, compatible DN250 PN10/16, 10" 150lbs, 10K 250	
	CMJ	DN80 PN10/16 B1, 316L flange EN1092-1 (DIN2527 C)	
	COJ	DN100 PN10/16 B1, 316L flange EN1092-1 (DIN2527 C)	
	ALJ	3" 150lbs RF, 316/316L flange ANSI B16.5	
	APJ	4" 150lbs RF, 316/316L flange ANSI B16.5	
	KLJ	10K 80A RF, 316L flange JIS B2220	
	KPJ	10K 100A RF, 316L flange JIS B2220	
	YY9	Special version, TSP-No. to be spec.	
60	Output; Operation:		
	A	4-20mA SIL HART; 4-line display VU331, envelope curve display on site	
	B	4-20mA SIL HART; w/o display, via communication	
	K	4-20mA SIL HART; prepared for FHX40, remote display (Accessory)	
	C	PROFIBUS PA; 4-line display VU331, envelope curve display on site	
	D	PROFIBUS PA; w/o display, via communication	
	L	PROFIBUS PA; prepared for FHX40, remote display (Accessory)	
	E	FOUNDATION Fieldbus; 4-line display, envelope curve display on site	
	F	FOUNDATION Fieldbus; w/o display, via communication	

Accessories

Weather protection cover

A Weather protection cover made of stainless steel is recommended for outdoor mounting (order code: 543199-0001). The shipment includes the protective cover and tension clamp.

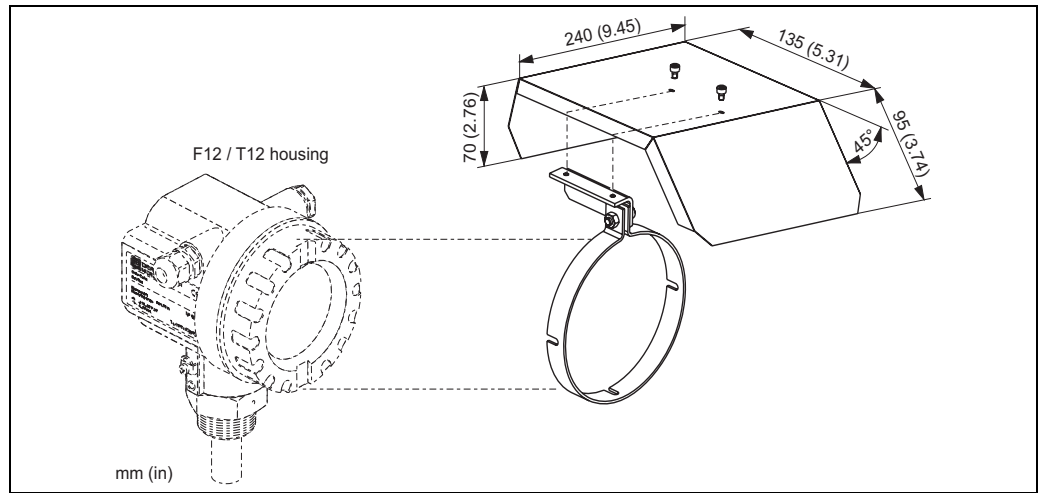

Remote display FHX40

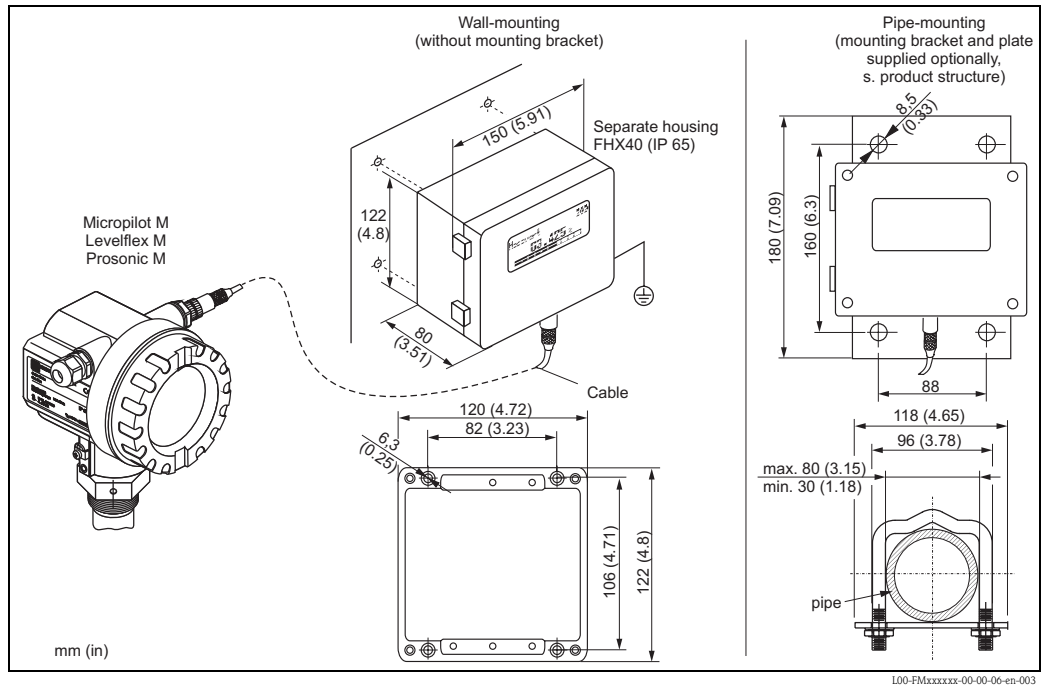

Technical data (cable and housing) and product structure:

Max. cable length	20 m (66 ft)
Temperature range	-40 °C to +60 °C (-40 °F to +140 °F)
Degree of protection	IP65/67 (housing); IP68 (cable) acc. to IEC60529
Materials	Housing: AlSi12; cable glands: nickle plated brass
Dimensions [mm (in)]	122x150x80 (4.8x5.91x3x15) / HxWxD

010	Approval:
	A Non-hazardous area 2 ATEX II 2G Ex ia IIC T6 3 ATEX II 2D Ex ia IIIC T80°C G IECEx zone1 Ex ia IIC T6/T5 S FM IS Cl.I Div.1 Gr.A-D, zone 0 U CSA IS Cl.I Div.1 Gr.A-D, zone 0 N CSA General Purpose K TIIS Ex ia IIC T6 C NEPSI Ex ia IIC T6/T5 Y Special version, TSP-No. to be spec.
020	Cable:
	1 20m/65ft; for HART 5 20m/65ft; for PROFIBUS PA/FOUNDATION Fieldbus 9 Special version, TSP-No. to be spec.
030	Additional option:
	A Basic version B Mounting bracket, pipe 1" / 2" Y Special version, TSP-No. to be spec.
995	Marking:
	1 Tagging (TAG), see additional spec.
FHX40 -	Complete product designation

For connection of the remote display FHX40 use the cable which fits the communication version of the respective instrument.

**Horn cover for
80 mm (3") and 100 mm (4")
horn antenna**

Technical data

Materials	
Horn cover	PTFE
Screws	316L
Holding ring	316L
Contact ring	316L
O-ring seal	Silicone
Flat seal	PTFE

Process conditions	
Vessel pressure max.	0,5 bar (7.252 psi)
Process temperature max.	130 °C (266 °F)

Dimensions

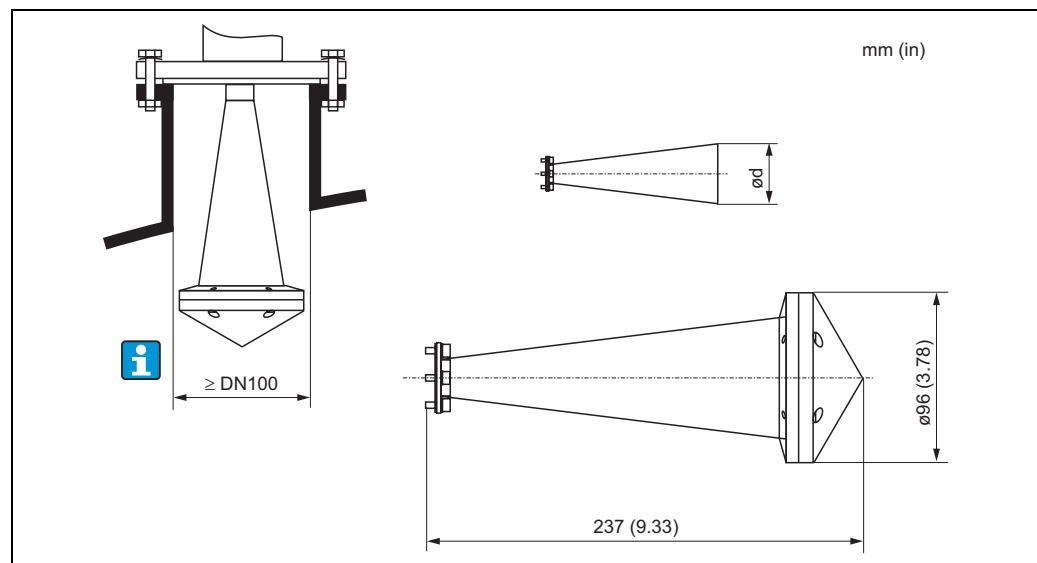

Horn cover for horn antenna 80 mm (3")
 – for antenna diameter $d = 75$ mm (2.95 in)
 – for FMR240: antenna variant G, 4
 – for FMR250: antenna variant D

Note!

The horn cover is not allowed to use in areas, where explosion proofed equipment is necessary.

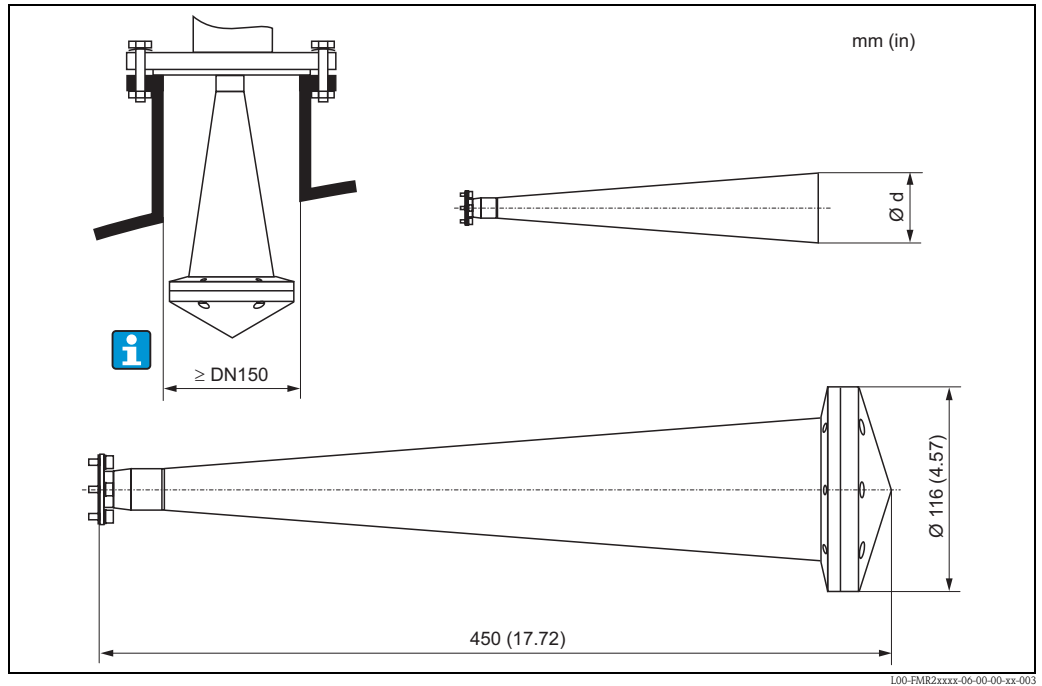

Horn cover for horn antenna 100 mm (4")
 – for antenna diameter $d = 95$ mm (3.74 in)
 – for FMR240: antenna variant H, S
 – for FMR250: antenna variant E

Note!

The horn cover is not allowed to use in areas, where explosion proofed equipment is necessary.

Ordering information

Horn antenna	80 mm (3")	100 mm (4")
Order code	71105890	71105889

Commubox FXA195 HART

For intrinsically safe communication with FieldCare via the USB interface.
 For details refer to TI00404F/00/EN.

Commubox FXA291

The Commubox FXA291 connects Endress+Hauser field instruments with CDI interface (= Endress+Hauser Common Data Interface) to the USB interface of a personal computer or a notebook.
 For details refer to TI00405C/07/EN.

Note!

For the instrument you need the "ToF Adapter FXA291" as an additional accessory.

ToF Adapter FXA291

The ToF Adapter FXA291 connects the Commubox FXA291 via the USB interface of a personal computer or a notebook to the instrument. For details refer to KA00271F/00/A2.

Documentation

Technical Information**Fieldgate FXA320, FXA520**

Technical Information for Fieldgate FXA320/520, TI00369F/00/EN.

Operating Instructions**Micropilot M**

Correlation of operating instructions to the instrument:

Output	Communication	Operating Instructions	Description of Instrument Functions	Brief Operating Instructions (in the Instrument)
A, B, K	HART	BA00284F/00/EN	BA00291F/00/EN	KA00235F/00/A2
C, D, L	PROFIBUS PA	BA00331F/00/EN	BA00291F/00/EN	KA00235F/00/A2
E, F, M	FOUNDATION Fieldbus	BA00336F/00/EN	BA00291F/00/EN	KA00235F/00/A2

Certificates

Correlation of safety instructions (XA) and certificates (ZD, ZE) to the instrument:

Feature	Variant	ZD00021F	ZD00209F	ZD00208F	ZD00171F	ZD00170F	ZD00169F	ZD00168F	XA00448F	XA00447F	XA00446F	XA00445F	XA00345F	XA00344F	XA00343F	XA00342F	XA00315F	XA00314F	XA00313F	XA00233F
		<p>10 Approval:</p> <p>Non-hazardous area A</p> <p>ATEX II 1/2GD Ex ia IIC T6, Alu blind cover B</p> <p>ATEX II 1/2G Ex ia IIC T6,ATEX II 1/3D C</p> <p>ATEX II 1/2D, Alu blind cover D</p> <p>ATEX II 1/3D E</p> <p>ATEX II 3G Ex nA II T6 G</p> <p>NEPSI Ex ia IIC T6 I</p> <p>NEPSI Ex d(ia)ia IIC T6 J</p> <p>TIIS Ex d (ia) IIC T3 L</p> <p>CSA General Purpose N</p> <p>NEPSI DIP Q</p> <p>FM IS Cl.I,II,III Div.1 Gr.A-G, zone 0, 1, 2 S</p> <p>FM XP Cl.I,II,III Div.1 Gr.A-G, zone 1, 2 T</p> <p>CSA IS Cl.I,II,III Div.1 Gr.A-G, zone 0, 1, 2 U</p> <p>CSA XP Cl.I,II,III Div.1 Gr.A-G, zone 1, 2 V</p> <p>Special version Y</p> <p>ATEX II 1/2G Ex ia IIC T6 1</p> <p>ATEX II 1/2G Ex d (ia) IIC T6 4</p>																		
<p>60 Output; Operation:</p> <p>4-20mA SIL HART, 4-line display VU331¹⁾ A</p> <p>4-20mA SIL HART. w/o display²⁾ B</p> <p>PROFIBUS PA, 4-line display VU331¹⁾ C</p> <p>PROFIBUS PA, w/o display²⁾ D</p> <p>FOUNDATION Fieldbus, 4-line display¹⁾ E</p> <p>FOUNDATION Fieldbus, w/o display²⁾ F</p> <p>4-20mA SIL HART, prepared for FHX40 K</p> <p>PROFIBUS PA, prepared for FHX40 L</p> <p>FOUNDATION Fieldbus, prepared for FHX40 M</p> <p>Special version Y</p>																				
<p>70 Housing:</p> <p>F12 Alu, coated IP65 NEMA4X A</p> <p>F23 316L IP65 NEMA4X B</p> <p>T12 Alu, coated IP65 NEMA4X³⁾ C</p> <p>T12 Alu, coated IP65 NEMA4X + OVP^{3,4)} D</p> <p>Special version Y</p>																				

- 1) Envelope curve display on site.
- 2) Via communication.
- 3) Separate conn. compartment.
- 4) OVP = overvoltage protection.

Safety manual

Functional safety manual for Micropilot M (→ SD00327F/00/EN).

This product may be protected by at least one of the following patents.
Further patents are pending.

- US 5,387,918 \cong EP 0 535 196
- US 5,689,265 \cong EP 0 626 063
- US 5,659,321
- US 5,614,911 \cong EP 0 670 048
- US 5,594,449 \cong EP 0 676 037
- US 6,047,598
- US 5,880,698
- US 5,926,152
- US 5,969,666
- US 5,948,979
- US 6,054,946
- US 6,087,978
- US 6,014,100

Instruments International

Endress+Hauser
Instruments International AG
Kaegenstrasse 2
4153 Reinach
Switzerland

Tel. +41 61 715 81 00
Fax +41 61 715 25 00
www.endress.com
info@ii.endress.com

Endress+Hauser 
People for Process Automation

