



DG — Two-point control, directly operated

The variable pump can be set to a minimum swivel angle by connecting an external control pressure to port X.

This will supply control fluid directly to the stroke piston; a minimum control pressure of $p_{st} \geq 725$ psi (50 bar) is required. ◦

The variable pump can only be switched between $V_{g \max}$ or $V_{g \min}$ ◦

Please note, that the required control pressure at port X is directly dependent on the actual operating pressure p_B in port B. (See control pressure characteristic).

Control pressure $p_{st} = 0$ psi (0 bar) $\hat{=}$ $V_{g \max}$
 Control pressure $p_{st} \geq 725$ psi (50 bar) $\hat{=}$ $V_{g \min}$

Control pressure characteristic

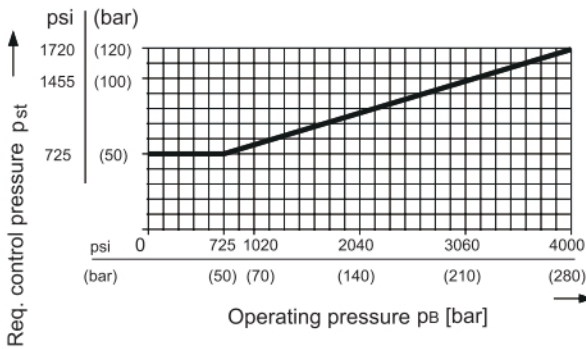

Circuit diagram

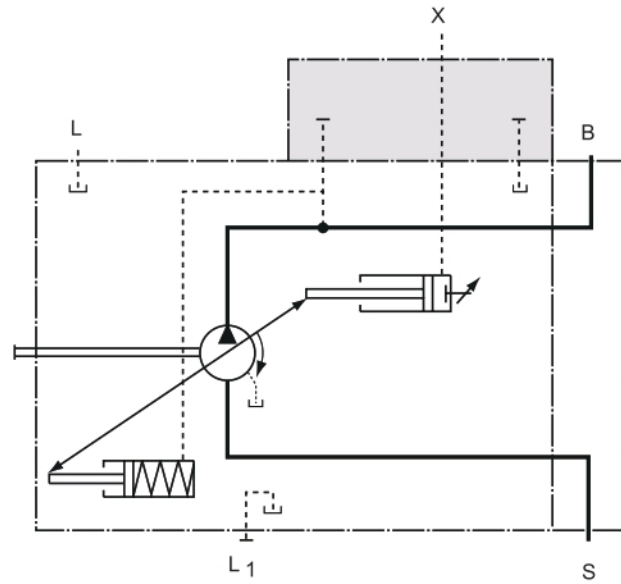

	Port for
B	Service line
S	Suction line
L \ L1	Case drain(L1 plugged)
X	Pilot pressure

DR — Pressure control

A

10

PA10VSO

The pressure control limits the maximum pressure at the pump output within the pump control range. The variable pump only supplies as much hydraulic fluid as is required by the consumers. If the operating pressure exceeds the pressure setpoint set at the integrated pressure valve, the pump will adjust towards a smaller displacement and the control deviation will be reduced. The pressure can be set steplessly at the control valve.

Static characteristic

(at $n_1 = 1800 \text{ rpm}$; $t_{\text{fluid}} = 122^\circ\text{F}$ (50°C)

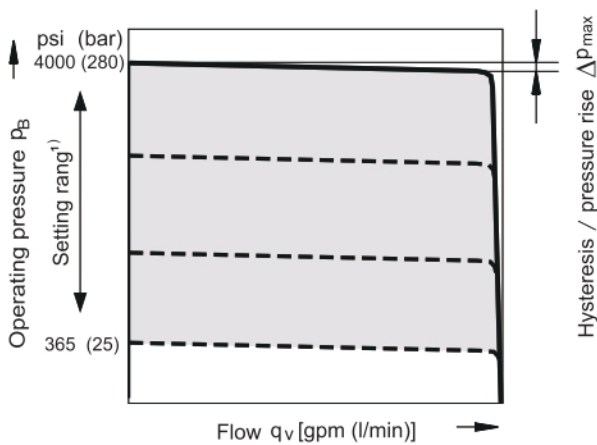

¹⁾In order to prevent damage to the pump and the system, this setting range is the permissible setting range and must not be exceeded. The range of possible settings at the valve are greater.

Circuit diagram, sizes 18 to 100

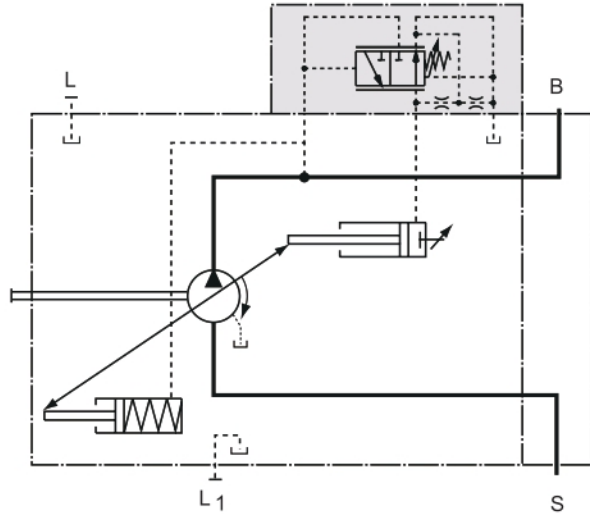

Circuit diagram, size 140

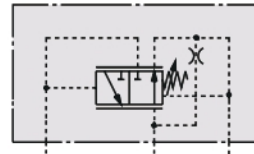

	Port for
B	Service line
S	Suction line
L、L1	Case drain(L1 plugged)

Control data

Hysteresis and repeatability Δp_{max} approx. 3 bar

Pressure rise, maximum

NG	18	28	45	71	100	140
Δp psi	60	60	90	8	115	175
(bar)	(4)	(4)	(6)	(8)	(10)	(12)

Contr. fluid consum__max. approx. 0.8 gpm (3 l/min)
please following page A-8

DRG — Pressure control, remotely operated



A pressure relief valve can be externally piped to port X for remote setting of pressure below the setting of the DR control valve spool. This relief valve is not included in the delivery contents of the DRG control.

The differential pressure at the DRG control valve is set as standard to 290 psi (20 bar). This results in a pilot oil flow to the relief valve of approx. 0.4 gpm (1.5 l/min) at port X. If another setting is required (range from 145 to 320 psi (10-22 bar)) please state in clear text.

The max. length of piping should not exceed 6.6 ft (2m).

Static characteristic

(at $n_1 = 1800 \text{ rpm}$; $t_{\text{fluid}} = 122^\circ\text{F}$ (50 °C))

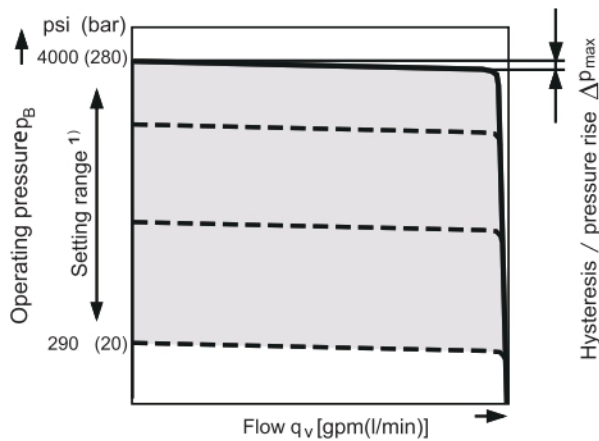

¹⁾ In order to prevent damage to the pump and the system, this setting range is the permissible setting range and must not be exceeded.

The range of possible settings at the valve are greater.

Circuit diagram, sizes 18 to 100

Not included in the delivery contents

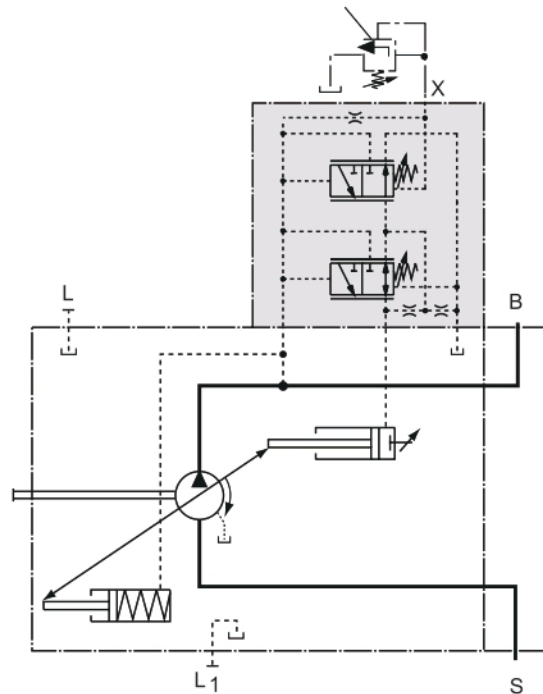

Circuit diagram, size 140

Not included in the delivery contents

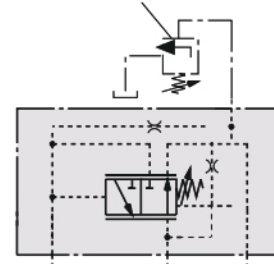

		Port for
B		Service line
S		Suction line
L · L1		Case drain (L1 plugged)
X	NG 18 to 100 without adapter	Pilot pressure
X	NG 140 with adapter	Pilot pressure

Control data

Hysteresis and repeatability Δp_{max} approx. 45 psi (3 bar)

Pressure rise, maximum

NG	18	28	45	71	100	140
Δp psi (bar)	60 (4)	60 (4)	90 (6)	115 (8)	145 (10)	175 (12)

Contr. fluid consum__max. approx. 1.2 gpm (4.5 l/min) please following page A-8

DFR/DFR1 — Pressure and flow control



A

12

PA10VSO

In addition to the pressure control function, the pump flow may be varied by means of a differential pressure over an adjustable orifice (e.g. directional valve) installed in the service line to the actuator. The pump flow is equal to the actual required flow by the actuator, regardless of changing pressure levels.

The pressure control overrides the flow control function.

Note

The DFR1 version has no connection between X and the reservoir. Unloading the LS-pilot line must be possible in the valve system. Because of the flushing function sufficient unloading of the X-line must also be provided.

Static characteristic

Flow control at $n_1 = 1500 \text{ rpm}$; $t_{\text{fluid}} = 122^\circ\text{F} (50^\circ\text{C})$

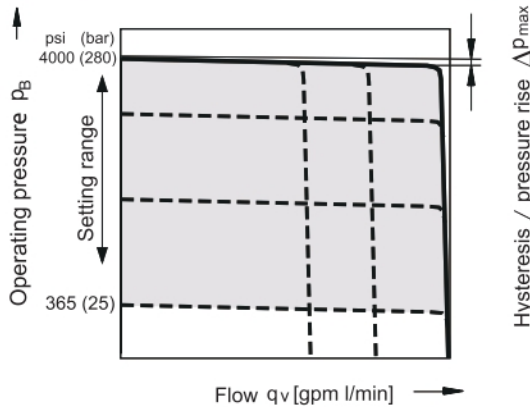

1) In order to prevent damage to the pump and the system, this setting range is the permissible setting range and must not be exceeded. The range of possible settings at the valve are greater.

Static characteristic at variable speed

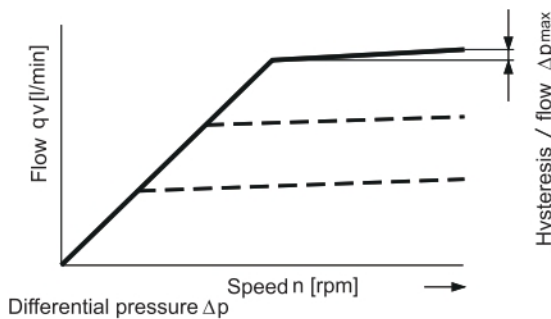

Standard setting : 200 to 320 psi (14 to 22 bar).
If another setting is required, please state in clear text. Relieving the load on port X to the reservoir results in a zero stroke ("standby") pressure which lies about 15 to 30 psi (1 to 2 bar) higher than the differential pressure Δp . System influences are not taken into account.

Circuit diagram, sizes 18 to 100

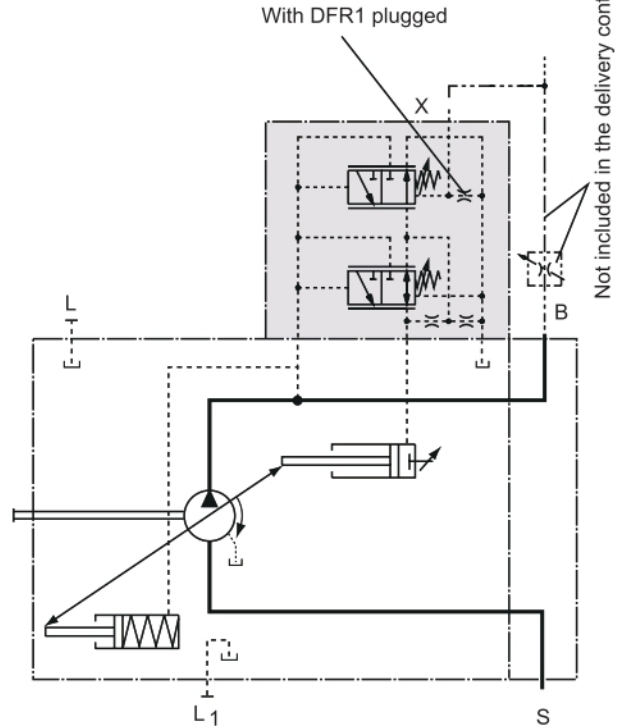

Circuit diagram, size 140

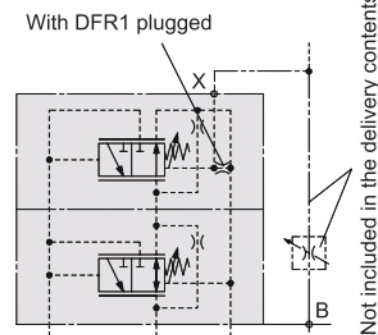

	Port for
B	Service line
S	Suction line
L, L1	Case drain (L1 plugged)
X	Pilot pressure

Control data

Data for pressure control DR, please see following page A-10. Maximum flow deviation measured at drive speed $n = 1500 \text{ rpm}$.

NG	18	28	45	71	100	140
$\Delta q_v \text{ max}$ gpm	0.24	0.26	0.48	0.75	1.06	1.60
l/min	(0.9)	(1.0)	(1.8)	(2.8)	(4.0)	(6.0)

Contr fluid consum. DFR __max.approx. 0.8 to 1.2 gpm (3 to 4.5 l/min)

Contr fluid consum. DFR1 __max.approx 0.8 gpm(3 l/min) please following page A-8



DFLR — Pressure, flow and power control

Execution of the pressure control like,DR(G),please following page A-10(11).
Execution of the flow control like DFR,DFR1,please following page A-12.

In order to achieve a constant drive torque with varying operating pressures, the swivel angle and with it the output flow from the axial piston pump is varied so that the product of flow and pressure remains constant.

Flow control is possible below the power control curve.

The power characteristic is set in the factory; when ordering,please state in clear text, e.g. 27HP (20 kW) at 1800 rpm

Control data

For pressure control DR data,please following page A-10.

For flow control DFR / DFR1 data,please following page A-12.

Static curves and torque characteristic

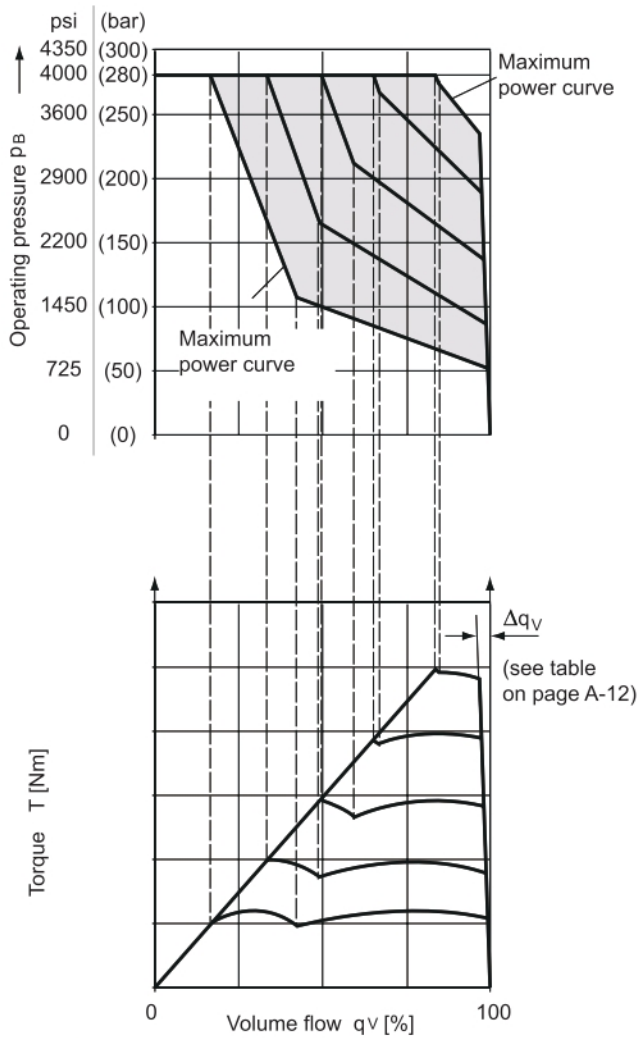

Circuit diagram, sizes 28 to 100

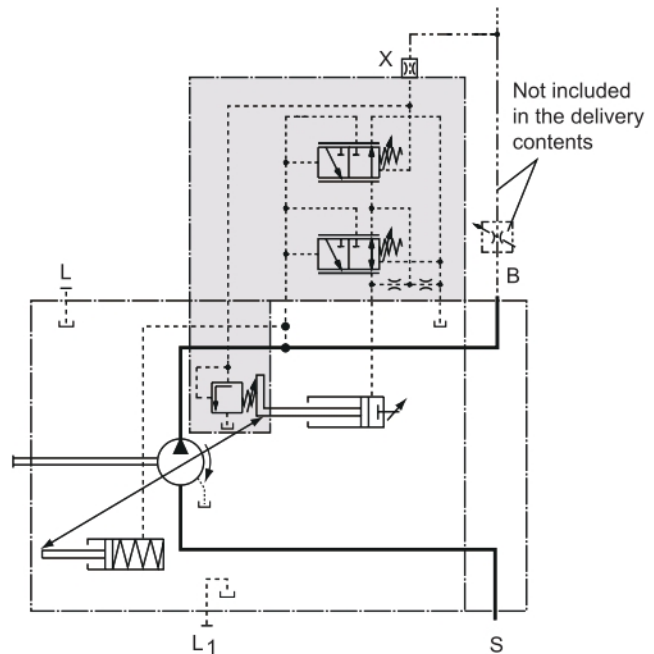

Circuit diagram, size 140

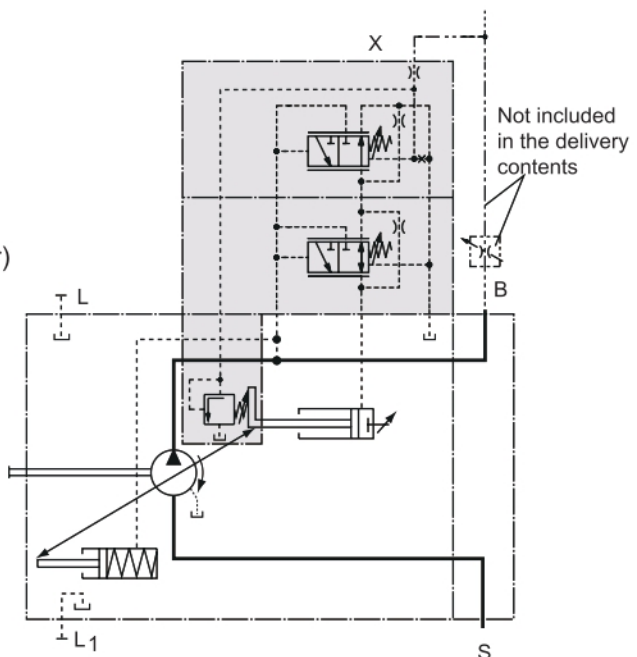

Control data

Beginning of control _____ 735 psi (50 bar)

Control fluid consumption_max.approx. 1.45 gpm (5.5 l/min)
please following page A-8

	Port for
B	Service line
S	Suction line
L · L1	Case drain (L1 plugged)
X	Pilot pressure

ED — Electro-hydraulic pressure control

A

14

PA10VSO

The ED valve is set to a certain pressure by a specified, variable solenoid current.

If there is a change at the consumer (load pressure), the position of the control piston changes. This causes an increase or decrease in the pump swivel angle (flow) in order to maintain the electrically set pressure level.

The pump thus only delivers as much hydraulic fluid as the consumers can take. The desired pressure level can be set steplessly by varying the solenoid current.

When the solenoid current signal drops towards a zero value, the maximum output pressure is limited to p_{max} by an adjustable hydraulic pressure cut-off (secure fail safe function in case of a loss of power e.g. for use as fan drives).

The response time characteristic of the ED-control was optimized for the use as a fan drive system.

When ordering, state the type of application in clear text.

Static current-pressure characteristic ED

(measured at pump in zero stroke – negative characteristic)

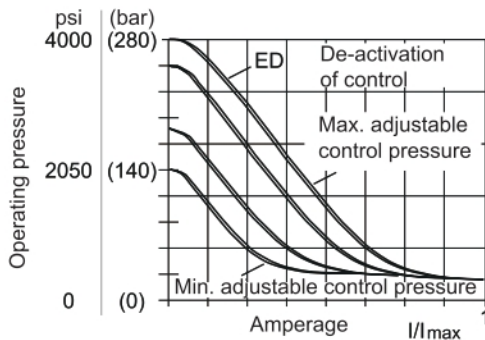

Hysteresis static current-press. characteristic < 45 psi 3 bar

Static flow-pressure characteristic

(at $n_1 = 1800 \text{ rpm}$; $t_{fluid} = 122^\circ\text{F}$ (50°C))

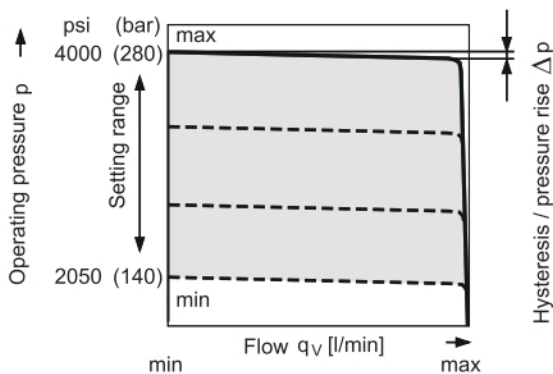

Control data

Stand-by standard setting 290 psi (20 bar), other values on request.

Hysteresis and pressure rise $\Delta p < 60 \text{ psi}$ (4 bar)

Control fluid consumption $0.8 \text{ to } 1.2 \text{ gpm}$ (3 to 4.5 l/min)

Influence of pressure setting on standby level

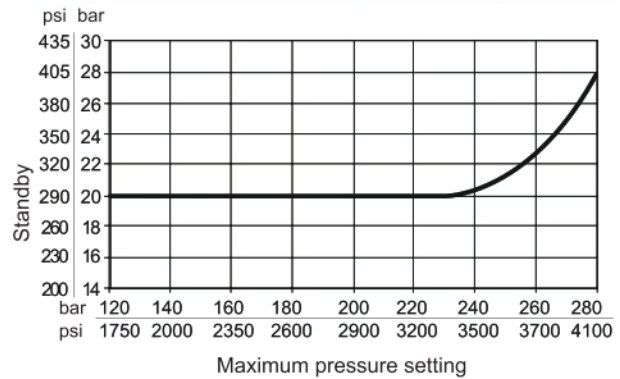

Circuit diagram ED..

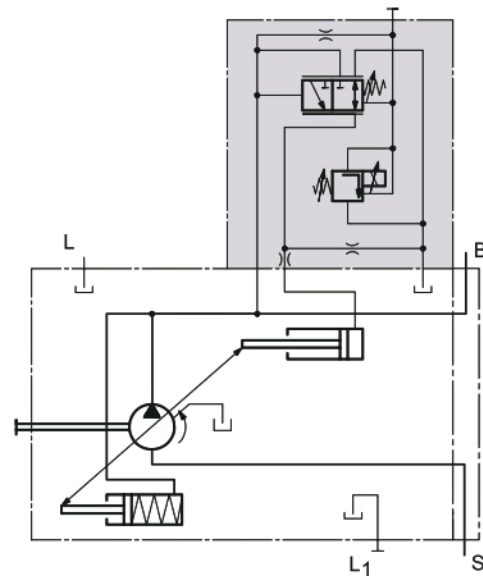

	Port for
B	Service line
S	Suction line
L \ L1	Case drain (L1 plugged)

Technical data, solenoid	ED71	ED72
Voltage	12 V(±20 %)	24 V(±20%)
Control current		
Control begin at $q_{v \text{ min}}$	100 mA	50 mA
End of control at $q_{v \text{ max}}$	1200 mA	600 mA
Limiting current	1.54 A	0.77 A
Nominal resistance (at 68°F (20°C))	5.5 Ω	22.7 Ω
Dither frequency	100 to 200 Hz	100 to 200 Hz
Actuated time	100 %	100 %

For type of protection, Please contact YEOSHE.
For details on the control electronics, following page A-15.

Operating temperature range at valve -4°F to 239°F (-20°C to $+115^\circ\text{C}$)



ER — Electro-hydraulic pressure control

The ER valve is set to a specific pressure by a specified, variable solenoid current.

If there is a change at the consumer (load pressure), the position of the control piston changes.

This causes an increase or decrease in the pump swivel angle (flow) in order to maintain the electrically set pressure level.

The pump thus only delivers as much hydraulic fluid as the consumers can take. The desired pressure level can be set steplessly by varying the solenoid current.

If the solenoid current drops to zero, the pressure is limited to p_{min} (stand-by).

Observe the project planning note on page A-1.

Static current-pressure characteristic ER

(measured at pump in zero stroke – positive characteristic)

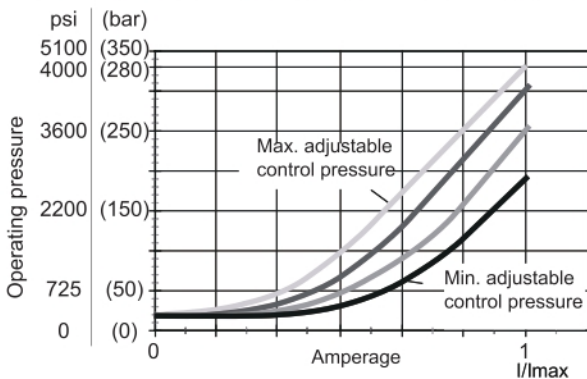

Hysteresis static current-press. characteristic < 45 psi (3 bar)
Influence of pressure setting on stand-by ± 30 psi (± 2 bar)

Static flow-pressure characteristic

(at $n = 1800$ rpm; $t_{fluid} = 122^\circ\text{F}$ (50°C))

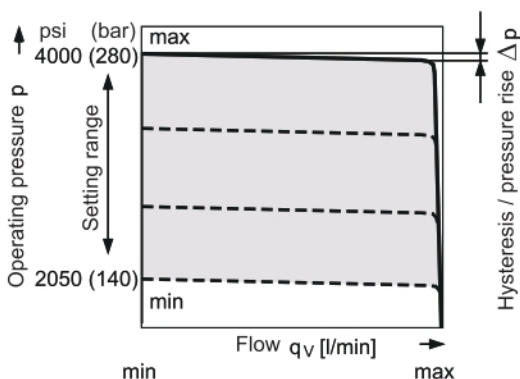

Control data

Standby standard setting 290 psi (20 bar), other values on request.

Hysteresis and pressure increase $\Delta p < 60$ psi (4 bar)
Control fluid consumption 0.8 to 1.2 gpm (3 to 4.5 l/min)

Circuit diagram ER..

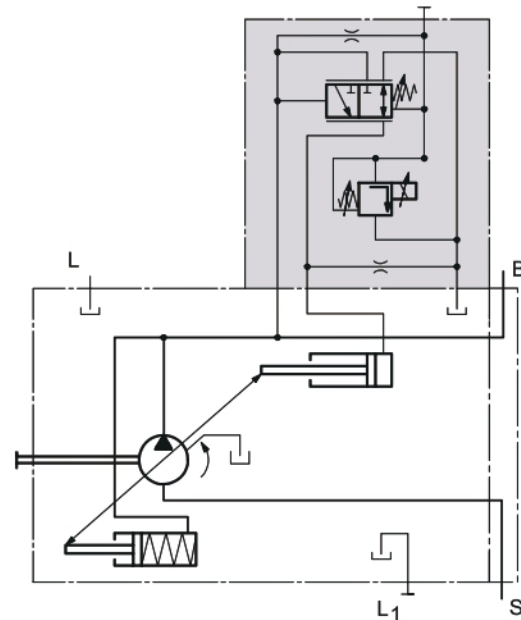

	Port for
B	Service line
S	Suction line
L · L1	Case drain (L1 plugged)

Technical data, solenoid	ER71	ER72
Voltage	12 V ($\pm 20\%$)	24 V ($\pm 20\%$)
Control current		
Control begin at $q_{v\ min}$	100 mA	50 mA
End of control at $q_{v\ max}$	1200 mA	600 mA
Limiting current	1.54 A	0.77 A
Nominal resistance 20°C	5.5 Ω	22.7 Ω
Dither frequency	100 to 200 Hz	100 to 200 Hz
Actuated time	100 %	100 %

For type of protection, Please contact YEOSHE.

Operating temperature range at valve -4°F to 239°F (-20°C to $+115^\circ\text{C}$)

The following electric controllers and amplifiers are available for controlling the proportional solenoids

- 1) Power outlets for 2 valves, can be actuated separately
- 2) Only 24V nominal voltage