

APPROVALS



ENGINEERING CODE
142HA13

APPROVED REFRIGERANT
R-134a

POWER SUPPLY
220-240 V 50 Hz

STANDARD CONDITIONS
ASHRAE

APPLICATION
HBP

COOLING CAPACITY
2973 W (HBP)

EFFICIENCY
2.41 W/W (HBP)

MOTOR TYPE
CSCR

STARTING TORQUE
HST

DATA

General Data

Type	Hermetic reciprocating
Technology Type	On-Off
Displacement	34.38 cm ³
Compressor Cooling	Fan/NotControlled/220
Fan Air Flow	800 m ³ /h
Expansion Device	Capillary Tube or Expansion Valve
Horse Power	1 1/4 hp
Max Condensing Pressure Operating	13.92 bar
Max Condensing Pressure Peak	15.62 bar
Power Supply	220-240 V 50 Hz
Evaporating Temperature Range	-15 °C to 10 °C

Electrical Data

Motor type	CSCR
Starting Torque	HST
Start Winding Resistance	8.7 Ω at 25° C
Run Winding Resistance	2 Ω at 25° C

Mechanical Data

Maximum Recommended Refrigerant Charge	800 g
Oil Charge	750 ml
Oil Type Configuration	ESTER
Oil Type Viscosity	ISO22
Pressurization	Dry air charge
Weight	19.8 Kg
Free Internal Volume	3.9 L

Electrical Components

	Description
Start Capacitor	72-88 Uf / 330 V
CSR / CSIR Box	YES
Starting Device	RVA4M3C-109
Run Capacitor	17.5
Motor Protection	T0335/C9

External Characteristics

Base Plate	Large	
Tray Holder	No	
Height	253 mm	
Connector	Internal Diameter	Shape
Suction	12.77 mm	Vertical/Copper
Discharge	8 mm	Slanted J/Copper
Process	6.42 mm	Vertical/Copper

PERFORMANCE

Rated Points

Condensing Temperature	Evaporating Temperature	Cooling Capacity	Power Consumption	Current	Gas Flow Rate	Efficiency
54.40°C	7.20°C	2973 W	1236 W	5.92 A	65.83 kg/h	2.41 W/W

Test Condition: ASHRAEHBP46, Fan/NotControlled/220, Return Gas 35°C, Evaporation 7.20°C, Condensing 54.40°C, Ambient 35°C, Liquid 46.1°C, Subcooling 8.3K. Data in accordance to EN

12900:2013 and AHRI 540:2015 polynomial equation and uncertainty guidance.

Performance Curve Data

Condensing Temperature 35°C

Evaporating Temperature °C	Cooling Capacity W	Power W	Current A	Gas Flow Rate kg/h	Efficiency W/W
-15	1795	710	3.68	33.12	2.53
-10	2206	782	3.97	40.85	2.82
-5	2671	852	4.26	49.64	3.14
0	3205	921	4.56	59.81	3.48
5	3821	990	4.86	71.71	3.86
10	4534	1059	5.17	85.66	4.28

Test Condition: ASHRAEHBP46, Fan/NotControlled/220, Return Gas 35°C, Ambient 35°C, Subcooling 8.3K. Data in accordance to EN 12900:2013 and AHRI 540:2015 polynomial equation and uncertainty guidance.

Condensing Temperature 45°C

Evaporating Temperature °C	Cooling Capacity W	Power W	Current A	Gas Flow Rate kg/h	Efficiency W/W
-15	1413	714	3.72	28.16	1.98
-10	1801	810	4.1	36.03	2.22
-5	2232	906	4.48	44.84	2.46
0	2720	1001	4.88	54.91	2.72
5	3279	1096	5.29	66.58	2.99
10	3922	1192	5.7	80.19	3.29

Test Condition: ASHRAEHBP46, Fan/NotControlled/220, Return Gas 35°C, Ambient 35°C, Subcooling 8.3K. Data in accordance to EN 12900:2013 and AHRI 540:2015 polynomial equation and uncertainty guidance.

Condensing Temperature 55°C

Evaporating Temperature °C	Cooling Capacity W	Power W	Current A	Gas Flow Rate kg/h	Efficiency W/W
-10	1340	848	4.23	29.23	1.58
-5	1742	962	4.71	38.16	1.81
0	2189	1076	5.21	48.24	2.03
5	2695	1190	5.72	59.80	2.26
10	3275	1306	6.25	73.17	2.51

Test Condition: ASHRAEHBP46, Fan/NotControlled/220, Return Gas 35°C, Ambient 35°C, Subcooling 8.3K. Data in accordance to EN 12900:2013 and AHRI 540:2015 polynomial equation and uncertainty guidance.

Operating Envelope

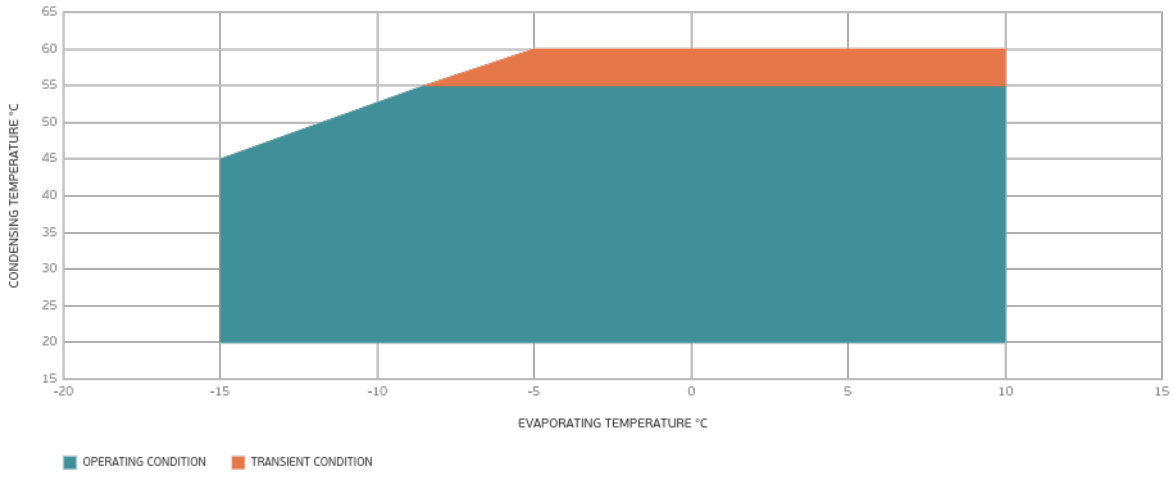

External Dimensions

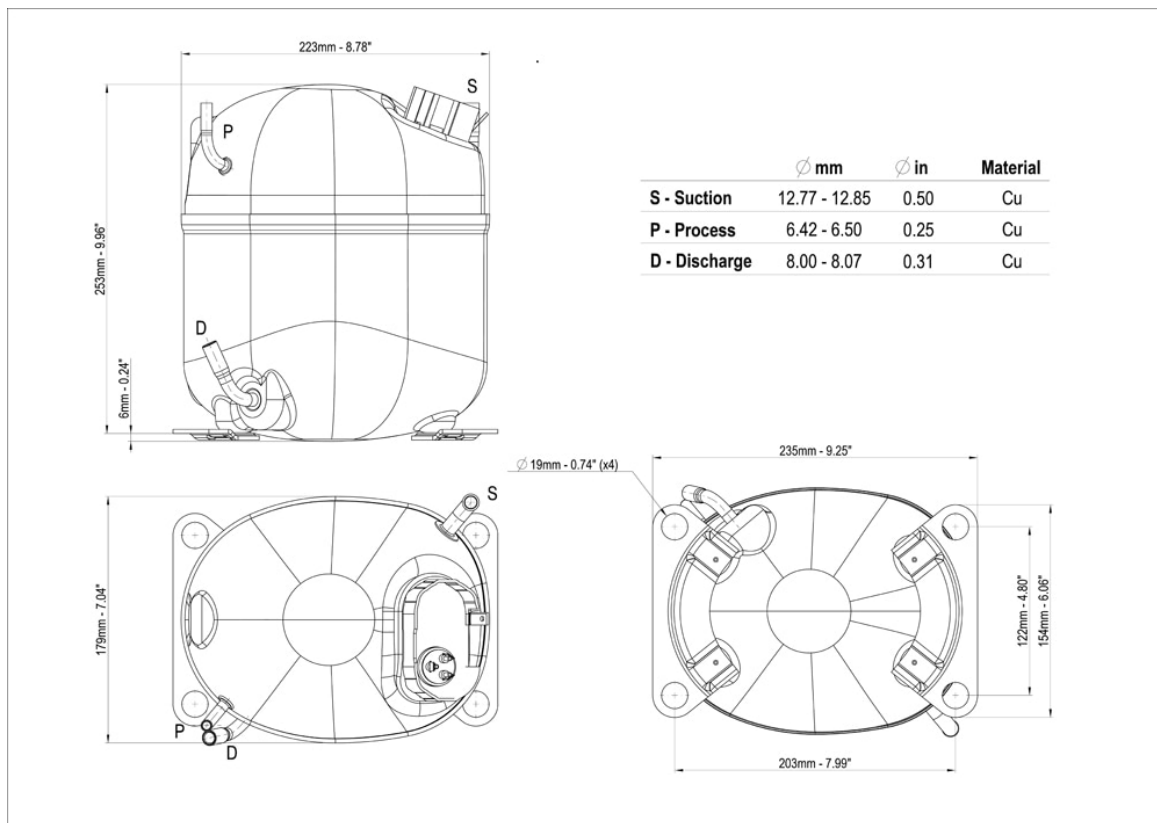

Wiring Diagram

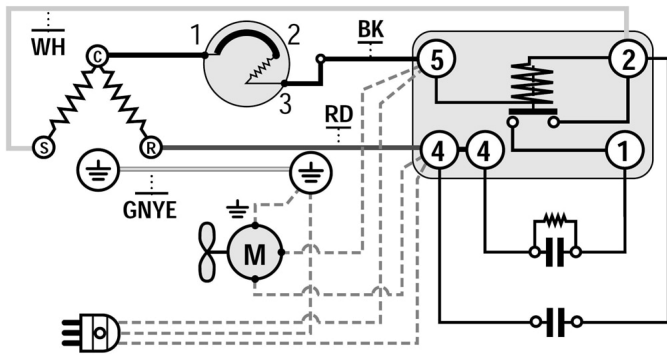

Assembly Instructions

