

QMRL/OP-0F

cubic photosensors



Micro Detectors

Italian Sensors Technology



Indicative image

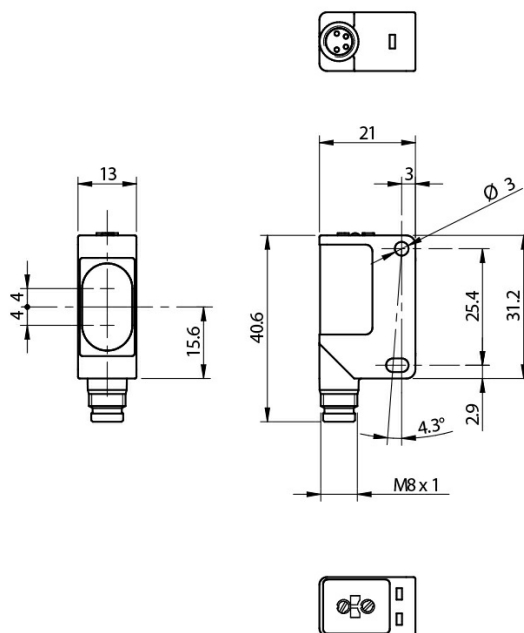

Detection properties

Nominal sensing distance 0,4...4m with reflector RL110 EGx5

Thermal drift of Sr $\leq 10\%$ Sr

Repeat Accuracy 5%

Sensitivity adjustment Trimmer

Application

Function Principle Transparent object

Notes with reflector RL110 EGx2

Optic position 90°

Outputs

Output type PNP

Output Function Lon/Don selectable

Switching frequency 1kHz

Electrical data

Operating Voltage	10...30Vdc
No-Load supply current	≤30mA
Load current	≤100mA
Leakage current	≤10μA
Output voltage drop	2V max. IL =100 mA
Max ripple content	10%
LED indicators	Yellow (status output) , green (excess gain)
Time delay before availability	≤200ms
Short-circuit protection	Yes
Reverse Polarity Protection	Yes
Emission	Red (630 nm)
Interference to external light	3000lux (incandescent lamp), 10000lux (sunlight)
Impulsive Overvoltage Protection	Yes

Mechanical data

Dimensions	40,6x21x13mm
Weight	10g
Housing Material	PA66
Connections	M8 Plug 4pin
Active Head Material	PMMA
Tightening torque	1Nm
Operating temperature	- 25°C...+ 70° C (Without freeze)
Storage temperature	- 30°C...+ 80° C (Without freeze)
Diameter/Dimension	Cubic

Test/Approvals

Approvals	CE cULus
EMC compatibility	EN 60947-5-2
Shocks and vibrations	Vibration IEC 60068-2-6 / Shock IEC 60068-2-27
Degree of protection	IP67

ELECTRICAL DIAGRAMS OF THE CONNECTIONS

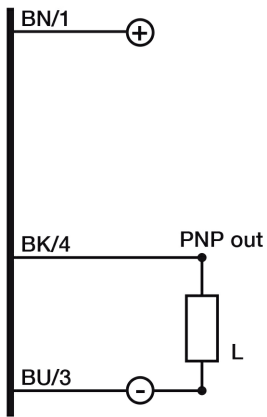

CONNECTOR

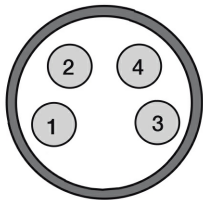

RESPONSE CURVES

Dimensione Spot

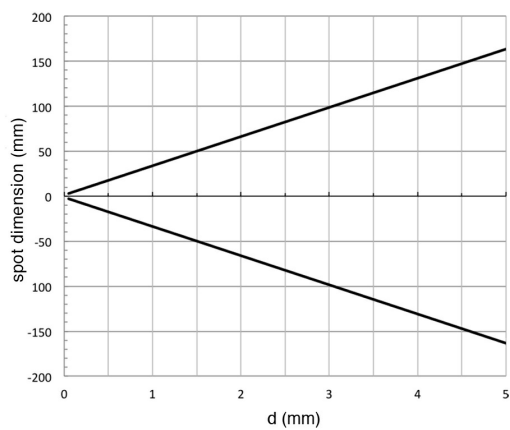

Disassamento Parallelo

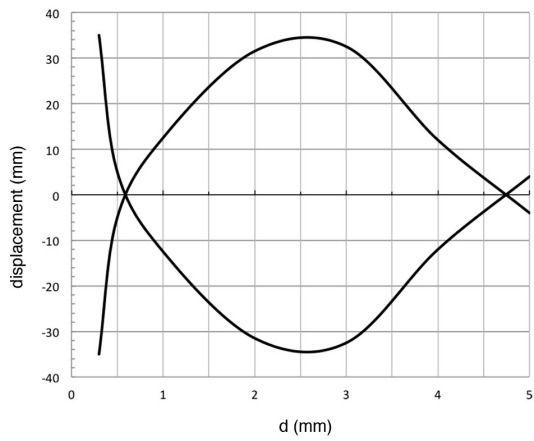

Eccesso di Guadagno

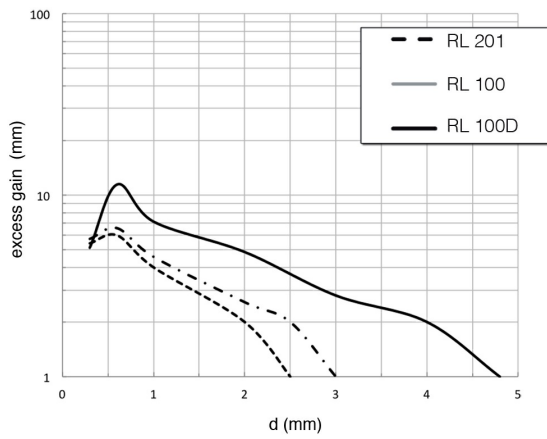

M.D. Micro Detectors S.p.A.

Strada S. Caterina, 235

41122 Modena (MO)

Tel. 059 420411

Fax 059 253973

E-mail info@microdetectors.com

date of printing

16/09/2021 14:48:02