

# PFK1/BP-3H

cylindrical inductive



Micro Detectors

Italian Sensors Technology



Indicative image

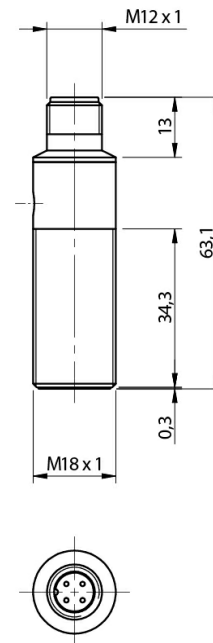

## Detection properties

Nominal sensing distance	8mm
Operanting distance	0...6,5mm
Standard target	24x24mm FE360
Correction Factor	copper: 0,20 / aluminium: 0,30 / brass: 0,40 / stainless steel: 0,65
Thermal drift of Sr	< 10%
Repeat Accuracy	5% (UB 24V Ta=23°C ±5°C)
Hysteresis	1 ... 20%

## Outputs

Output type	PNP
Output Function	NO + NC
Switching frequency	1,5kHz

## Electrical data

Operating Voltage	10...30Vdc
No-Load supply current	≤ 15mA
Load current	≤ 200mA
Leakage current	≤ 10μA
Output voltage drop	≤ 2V @200mA

Max ripple content	≤10%
LED indicators	Yellow LED output state
Time delay before availability	≤ 50ms
Short-circuit protection	Yes (auto-reset)
Reverse Polarity Protection	Yes
Protection against inductive loads	Yes

## Mechanical data

Mounting	Shielded
Dimensions	M18 x 1 / L = 63,1mm
Weight	55g
Housing Material	stainless steel AISI316L
Connections	M12 Plug
Active Head Material	PPS
Tightening torque	50Nm
Operating temperature	-40°C...+80°C (up to 100°C for short exposure during cleaning process)
Diameter/Dimension	M18

## Test/Approvals

Approvals	CE cULus
EMC compatibility	IEC 60947-5-2
Shocks and vibrations	Vibration IEC 60068-2-6 / Shock IEC 60068-2-27
Degree of protection	IP68, IP69K

## Accessories

Supplied Accessories	2 nuts M18x1
----------------------	--------------

---

# ELECTRICAL DIAGRAMS OF THE CONNECTIONS

---

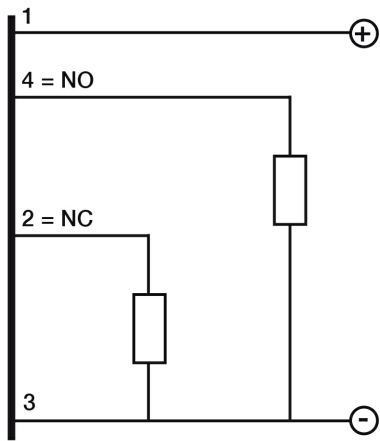

## CONNECTOR

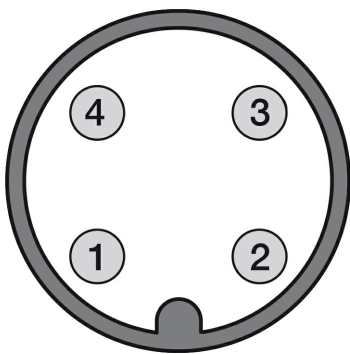

## INSTALLATION

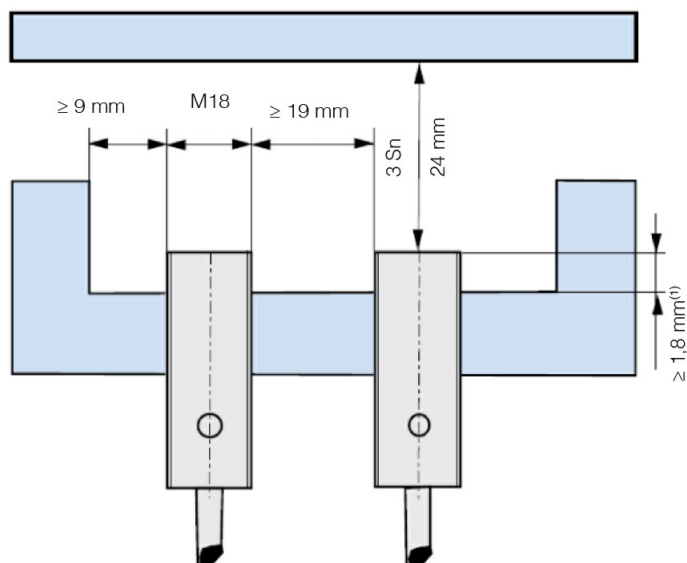

<sup>(1)</sup> ≥ 3,6 mm for non magnetic materials

# RESPONSE CURVES

---

## Disassamento Parallelo

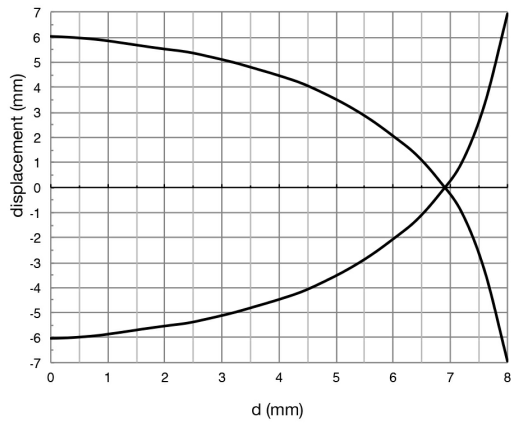

---

**M.D. Micro Detectors S.p.A.**

Strada S. Caterina, 235

41122 Modena (MO)

Tel. 059 420411

Fax 059 253973

E-mail [info@microdetectors.com](mailto:info@microdetectors.com)

**date of printing**

09/09/2021 10:57:32