

### TECHNICAL SPECIFICATION:

- All parts of fan should be properly assembled, no oil or dirt on the surface, no obvious distortion, mechanical damage and other defects.
- Fan rotation is flexible, no delay no operation sound, no scratch and other undesirable phenomena.
- The safety requirement of fan is performed according to GB12350-2009, the electrical strength is 1500V•min, and the insulation resistance is not less than 100M Ω at room temperature.
- Motor insulation class, F CLASS.
- Motor protection level, IP44, fan protection level, IP2X.
- The fan balance level is:  $1380 \pm 10\%$  r/min high G6. 3, vibration value is less than 5.4mm/s.
- MAER box.
- Built-in heat protector.

Test data at free:

Connection	UAC (V)±5%	f (Hz)	P1 (W)±10%	I (A)±10%	n (r/min)±10%	Noise db(A)
	1~220V	50	230	1.14	1380	67

### Performance parameters at key point:

	psf	I	P1	n	Q	Note
	(pa)	(A)	(W)	(r/min)	(m³/h)	
①	0	0.93	204	1394	4900	
②	27	1.01	222	1374	4534	
③	68	1.13	249	1339	3993	MAX EFF.
④	74	1.17	257	1324	3719	I MAX

PS: Fan working performance tested with MAER wall plate, and under standard atmospheric pressure at 20°C

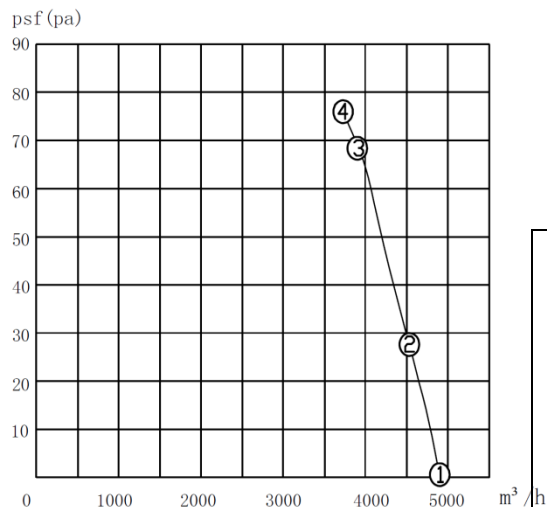

### WIRING DIAGRAM

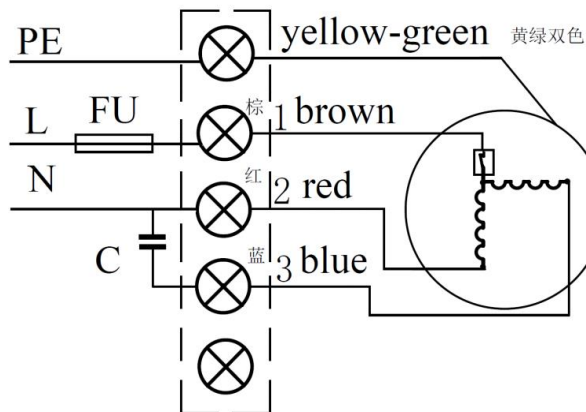

	Product model	<b>YDWF74L60P4-522N-450S</b>
	Product type	External rotor axial flow fan
	Customer	乌克兰 (Ukraine)
	Product number	MAER - 1803210
	Certification	CE, CCC

### Condition of use:

- Voltage and frequency: 1 ~ 220V + 5% (50 Hz)
- Qualification requirements: Terminal block, the recommended standard of lead wire is not less than 0.5mm².
- Installation position: vertical or upward.
- Ambient temperature: -40 ~ 80°C.

### THE EXTERNAL WIRING DIAGRAM:

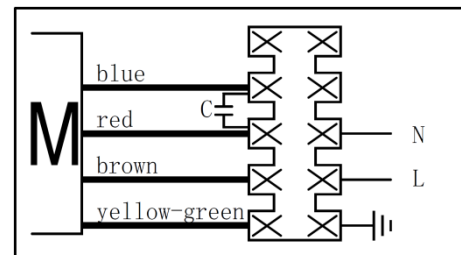

### MARK

**MAER** AXIAL FAN MOTOR  
MOTORS & FANS

**MODEL: YDWF74L60P4-522N-450 SUCTION  
4E-450-S**

VOLTAGE: 220V / 50Hz

N.W/G.W. 7.3/8.7 kg

MEAS: 50x50x22 cm

CL. F WITH TERMINAL BOX

20180509X

### Nameplate:

YDWF74L60P4-522N-450 S 1~220V50Hz 6μF / 450V  
249W 1.13A 1339r/min @ 68Pa  
CL. F IP54 2018/05

Tel: +380678807231, +380500679006  
web: [www.iceteco.com](http://www.iceteco.com)  
e-mail: [iceteko@gmail.com](mailto:iceteko@gmail.com)

	The signature	(date)(month)(year)	ZHEJIANG MAER FAN MOTOR CO., LTD.
state	Deliver before After the confirmat ion		
drawing			
audit			
approval			