



**APPROVALS**



**ENGINEERING CODE**  
513306244

**APPROVED REFRIGERANT**  
R-290

**POWER SUPPLY**  
220-240 V 50 Hz

**STANDARD CONDITIONS**  
ASHRAE

**APPLICATION**  
LBP

**COOLING CAPACITY**  
205 W (LBP)

**EFFICIENCY**  
1.37 W/W (LBP)

**MOTOR TYPE**  
CSIR

**STARTING TORQUE**  
HST

**DATA**

**General Data**

Type	Hermetic reciprocating
Technology Type	On-Off
Displacement	4.5 cm <sup>3</sup>
Compressor Cooling	Static/NotControlled/220
Expansion Device	Capillary Tube or Expansion Valve
Horse Power	1/5 hp
Power Supply	220-240 V 50 Hz
Evaporating Temperature Range	-40 °C to -10 °C

**Electrical Data**

Motor type	CSIR
Starting Torque	HST
Start Winding Resistance	21.1 Ω at 25° C
Run Winding Resistance	14.4 Ω at 25° C
Rated Load Amperage (RLA) at 50 Hz	1.35 A

## Mechanical Data

Oil Charge	180 ml
Oil Type Configuration	ESTER
Oil Type Viscosity	ISO22
Weight	7.76 Kg

## Electrical Components

	Description
Starting Device	Relay   MTRP-0015*
Start Capacitor	43-53 Uf / 330 V
Motor Protection	T0231/G6

## External Characteristics

Tray Holder	No	
Connector	Internal Diameter	Shape
Suction	6.1 mm	Slanted 42° up + 45° to Back/Copper
Discharge	4.94 mm	Slanted parallel BP+24° to Back/Copper
Process	6.1 mm	Slanted 45° up + 45° to Back/Copper

## PERFORMANCE

## Rated Points

Condensing Temperature	Evaporating Temperature	Cooling Capacity	Power Consumption	Current	Gas Flow Rate	Efficiency
54.40°C	-23.30°C	205 W	150 W	1.01 A	2.10 kg/h	1.37 W/W

Test Condition: ASHRAELBP32, Static/NotControlled/220, Return Gas 32.2°C, Evaporation -23.30°C, Condensing 54.40°C, Ambient 32.2°C, Liquid 32.2°C, Subcooling 22.2K. Data in accordance to EN

12900:2013 and AHRI 540:2015 polynomial equation and uncertainty guidance.

## Performance Curve Data

### Condensing Temperature 35°C

Evaporating Temperature °C	Cooling Capacity W	Power W	Current A	Gas Flow Rate kg/h	Efficiency W/W
-40	105	97	0.89	1.06	1.08
-35	137	107	0.9	1.38	1.27
-30	174	118	0.92	1.76	1.48
-25	219	128	0.94	2.22	1.7
-20	271	138	0.97	2.76	1.96
-15	331	146	1	3.38	2.27
-10	401	152	1.04	4.12	2.63

Test Condition: ASHRAELBP32, Static/NotControlled/220, Return Gas 32.2°C, Ambient 32.2°C, Liquid 32.2°C. Data in accordance to EN 12900:2013 and AHRI 540:2015 polynomial equation and uncertainty guidance.

### Condensing Temperature 45°C

Evaporating Temperature °C	Cooling Capacity W	Power W	Current A	Gas Flow Rate kg/h	Efficiency W/W
-40	94	99	0.9	0.95	0.95
-35	125	111	0.92	1.26	1.12
-30	162	124	0.94	1.64	1.31
-25	205	137	0.97	2.08	1.5
-20	256	150	1.01	2.61	1.71
-15	316	162	1.05	3.23	1.95
-10	385	172	1.09	3.95	2.23

Test Condition: ASHRAELBP32, Static/NotControlled/220, Return Gas 32.2°C, Ambient 32.2°C, Liquid 32.2°C. Data in accordance to EN 12900:2013 and AHRI 540:2015 polynomial equation and uncertainty guidance.

## Condensing Temperature 55°C

Evaporating Temperature °C	Cooling Capacity W	Power W	Current A	Gas Flow Rate kg/h	Efficiency W/W
-40	80	100	0.89	0.80	0.8
-35	110	113	0.92	1.11	0.97
-30	146	128	0.96	1.48	1.14
-25	189	144	1	1.92	1.31
-20	239	160	1.04	2.43	1.5
-15	297	176	1.09	3.04	1.7
-10	365	190	1.15	3.74	1.92

Test Condition: ASHRAELBP32, Static/NotControlled/220, Return Gas 32.2°C, Ambient 32.2°C, Liquid 32.2°C. Data in accordance to EN 12900:2013 and AHRI 540:2015 polynomial equation and uncertainty guidance.

## Operating Envelope

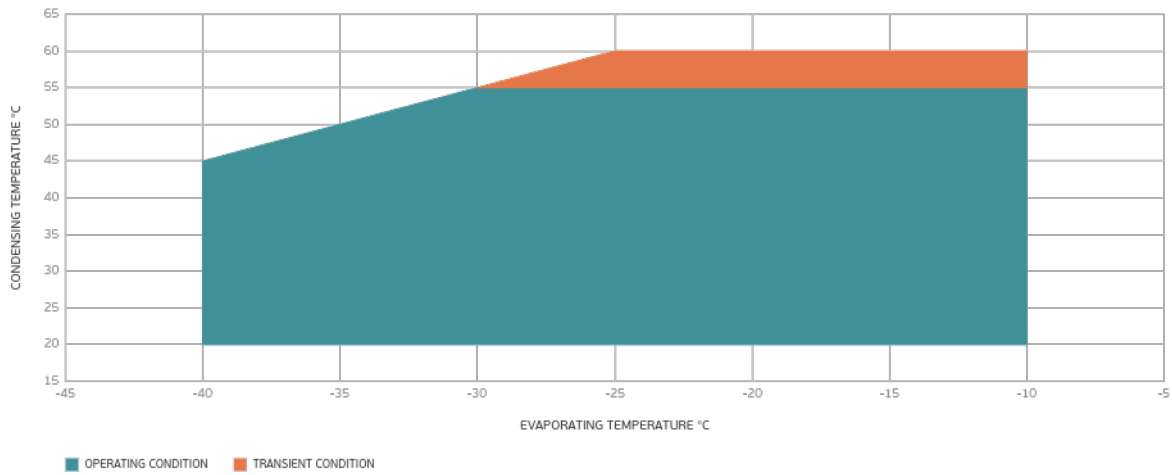

## External Dimensions

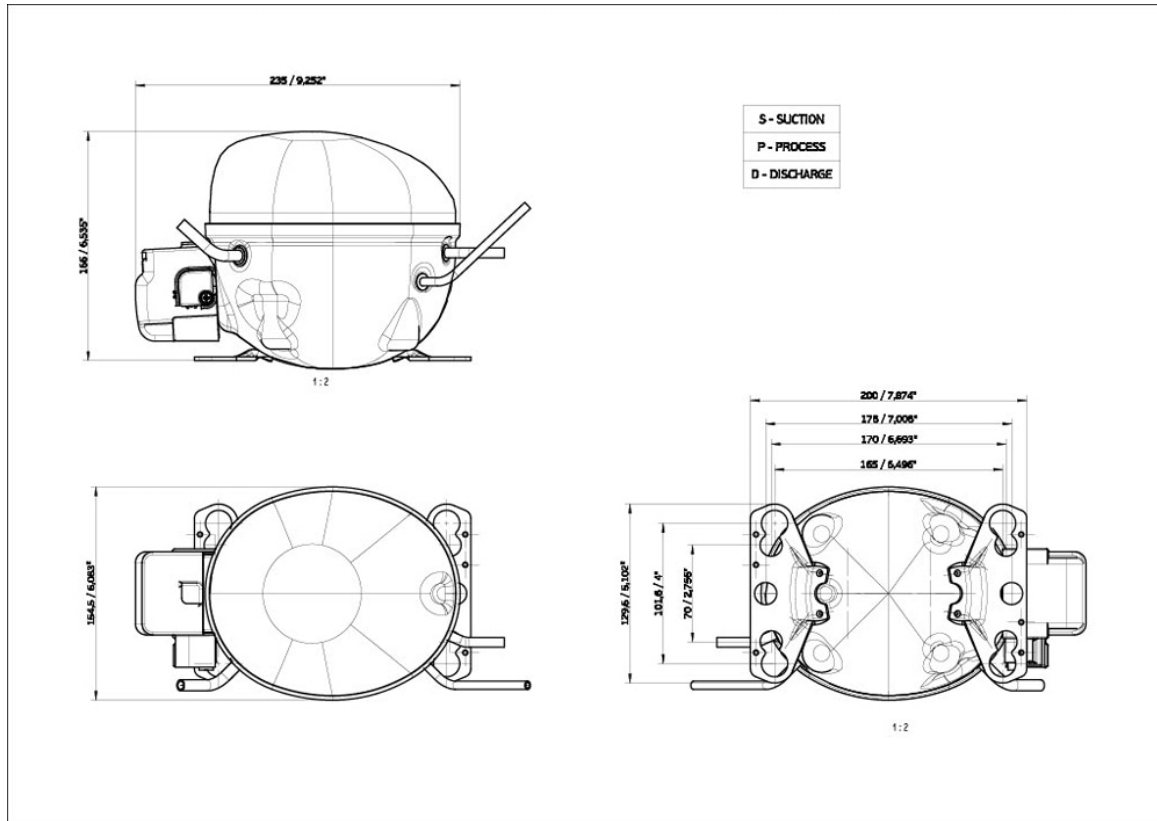

## Wiring Diagram

SM28-4

