

S 62 - S 63 - S65

LIBRETTO PEZZI DI RICAMBIO  
SPARE PARTS LIST



**SICE**  
AUTOMOTIVE EQUIPMENT

Ed. 05/2013

## PARTI DI RICAMBIO

Per ordinazioni specificare sempre il numero di matricola rilevabile sull'apposita targhetta posta sul dispositivo. Indicare sempre il numero di riferimento e il numero di codice del particolare.

## SPARE PARTS

When ordering always specify the serial number shown on the data label placed on the device. Please also always specify the reference and the code number of the spares you require.

S 62 - S 63 - S 65

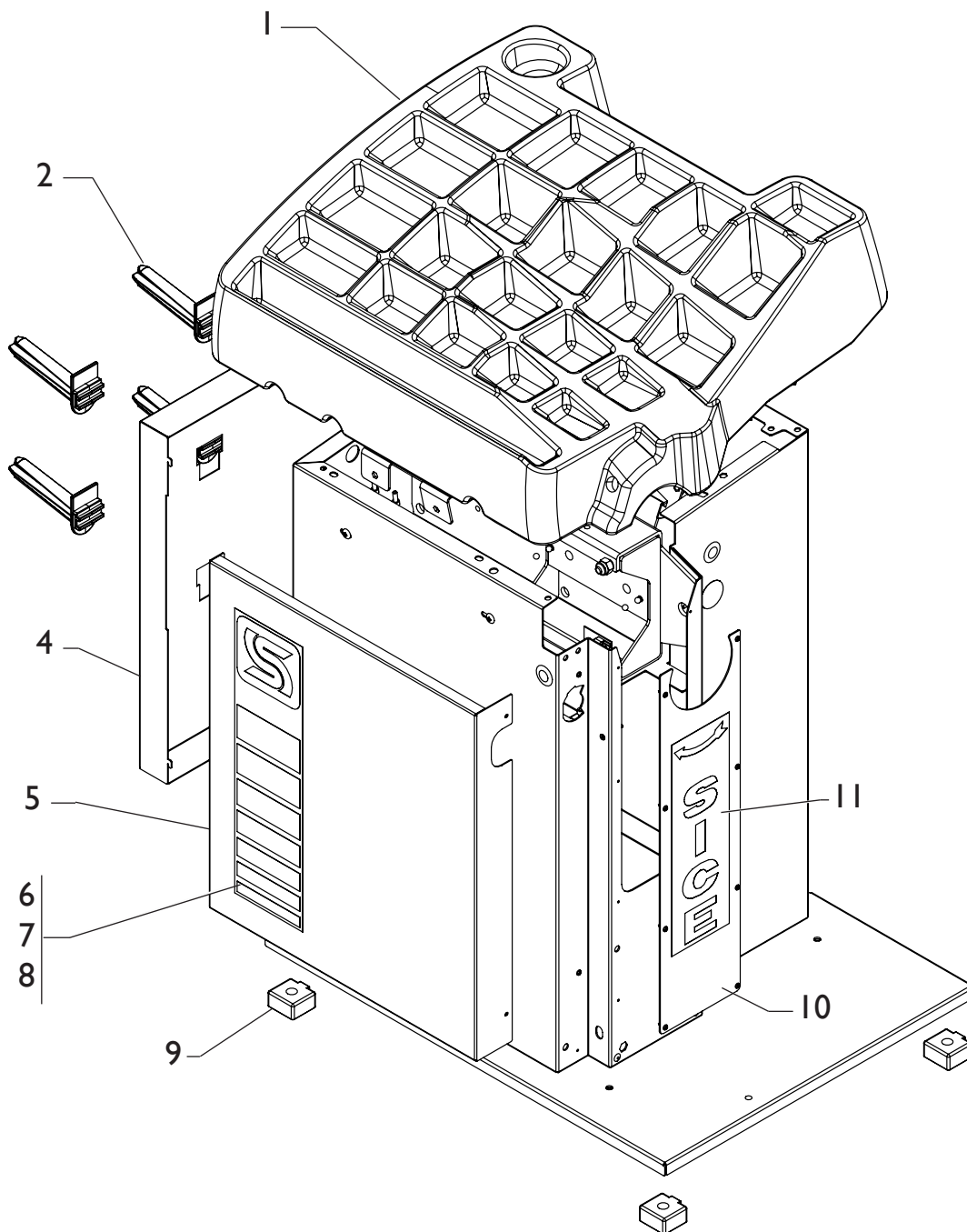

- 1 4-406558
- 2 438319
- 4 4-103002
- 5 4-102967
- 6 4-406670
- 7 4-407055
- 8 4-407243
- 9 4-406032
- 10 4-102945
- 11 4-406724

- COPERCHIO
- SUPPORTO
- PANNELLO LATERALE
- PANNELLO FRONTALE
- ADESIVO S63
- ADESIVO S65
- ADESIVO S62
- PIEDE
- PANNELLO
- ADESIVO SICE

- COVER
- SUPPORT
- SIDE PANEL
- FRONT PANEL
- LABEL
- LABEL
- LABEL
- FOOT
- PANEL
- LABEL

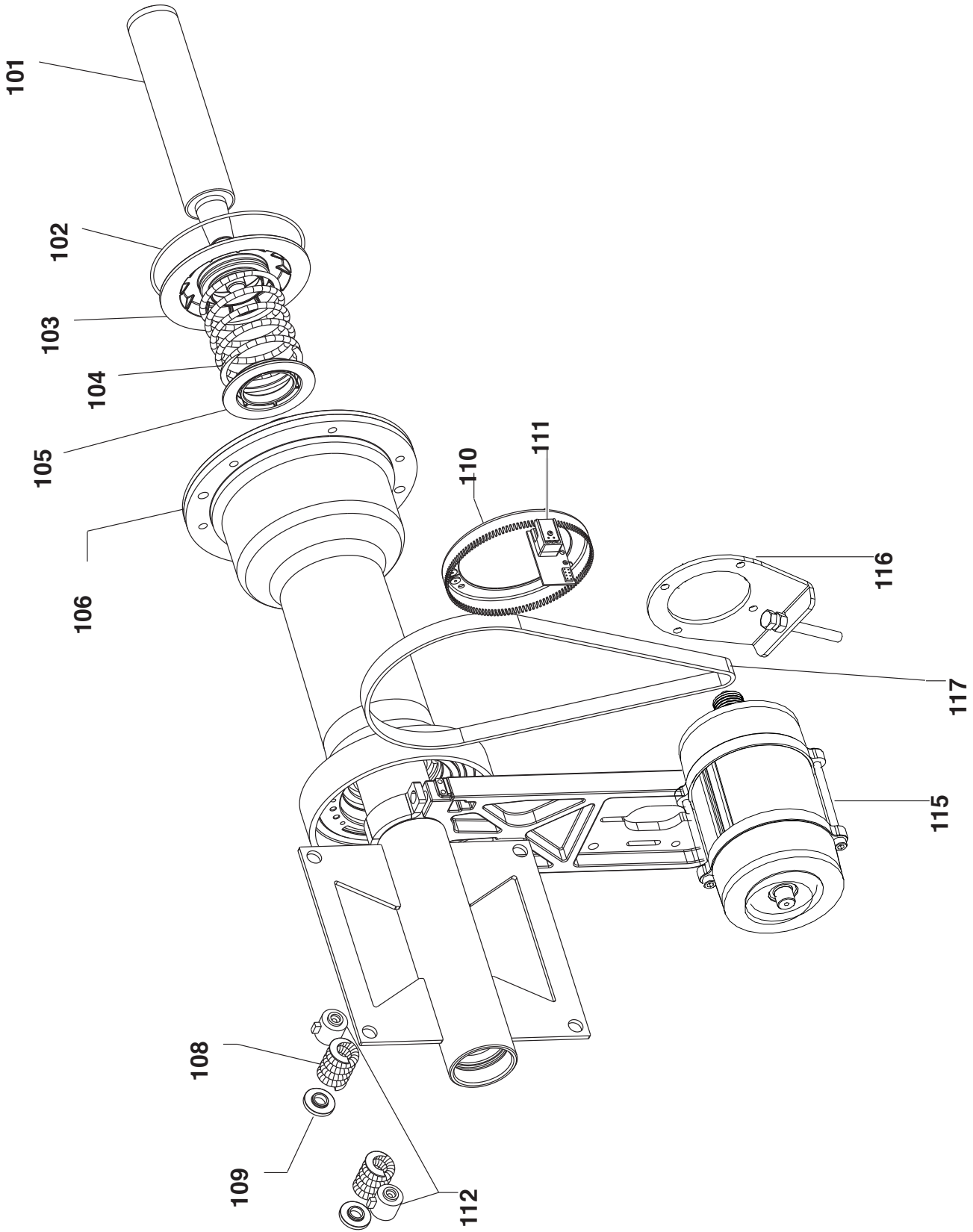

0101	5-101514	MOZZO	HUB
0102	4-101740	ANELLO	RING
0103	4-104590	DISCO	DISK
0104	4-104588	MOLLA	SPRING
0105	4-104589	DISCO	DISK
0106	5-103258	GRUPPO	ASSEMBLY
0108	4-104652	MOLLA	SPRING
0109	4-104650	BOCCOLA	BUSHING
0110	5-102161	KIT DISCO	DISK
0111	5-101447	SCHEDA ENCODER	ENCODER
0112	5-103533	PICK-UP	PICK-UP
0115	5-103200	MOTORE AC 230V+PULEGGIA	MOTOR+PULLEY
0115	5-103201	MOTORE AC 115V+PULEGGIA	MOTOR+PULLEY
0116	4-104598	FLANGIA	FLANGE
0117	3-03052	CINGHIA	BELT

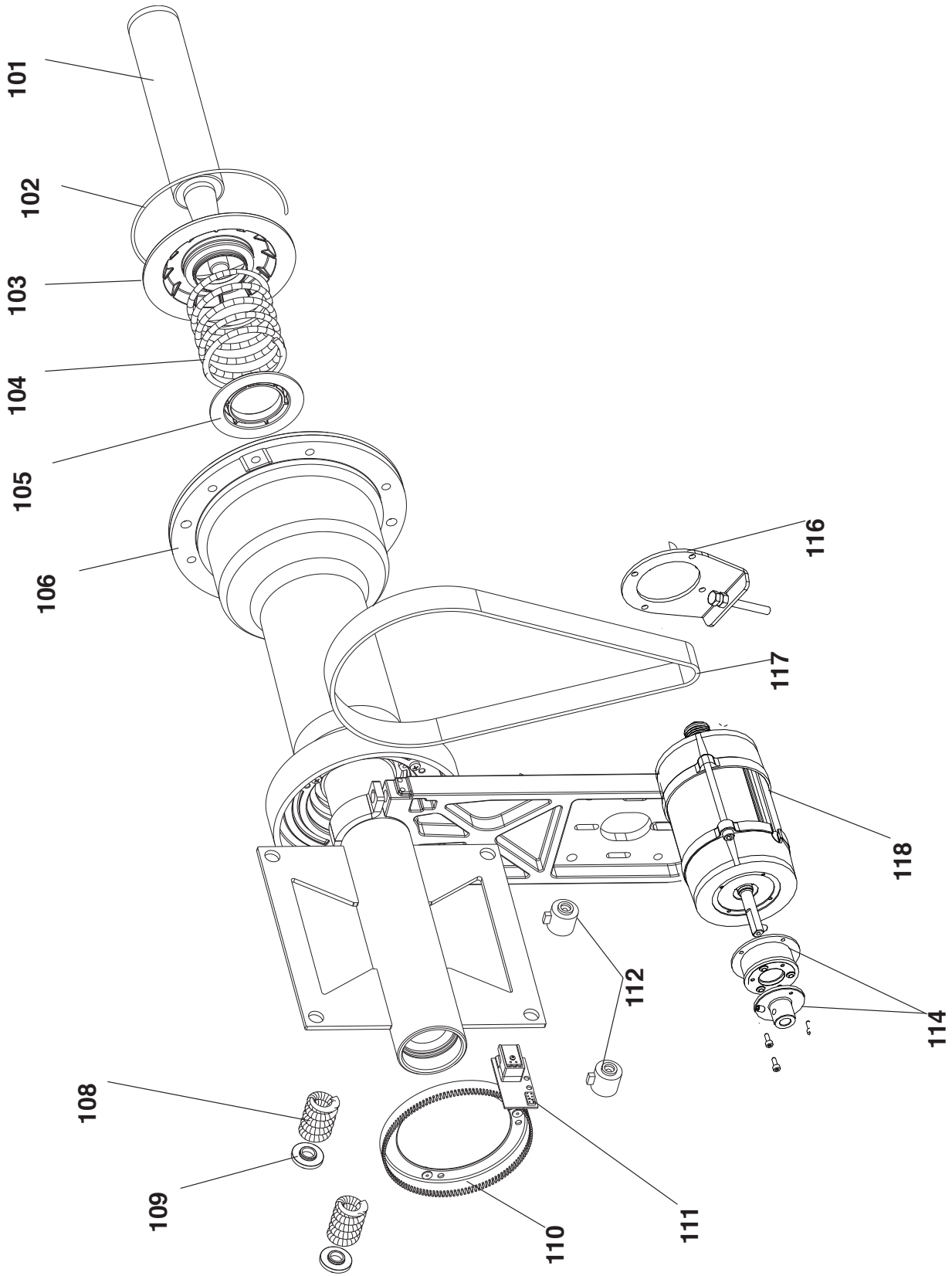

0101	5-101514	MOZZO	HUB
0102	4-101740	ANELLO	RING
0103	4-104590	DISCO	DISK
0104	4-104588	MOLLA	SPRING
0105	4-104589	DISCO	DISK
0106	5-103258	GRUPPO	ASSEMBLY
0108	4-104652	MOLLA	SPRING
0109	4-104650	BOCCOLA	BUSHING
0110	5-102161	KIT DISCO	DISK
0111	5-101447	SCHEDA ENCODER	ENCODER
0112	5-103533	PICK-UP	PICK-UP
0114	5-103692	FRENO+MOZZO+CONN	PIN
0116	4-104598	FLANGIA	FLANGE
0117	3-03052	CINGHIA	BELT
0118	5-100172	MOTORE AC 230V+PULEGGIA	MOTOR
0118	5-100180	MOTORE AC 115V+PULEGGIA	MOTOR

200

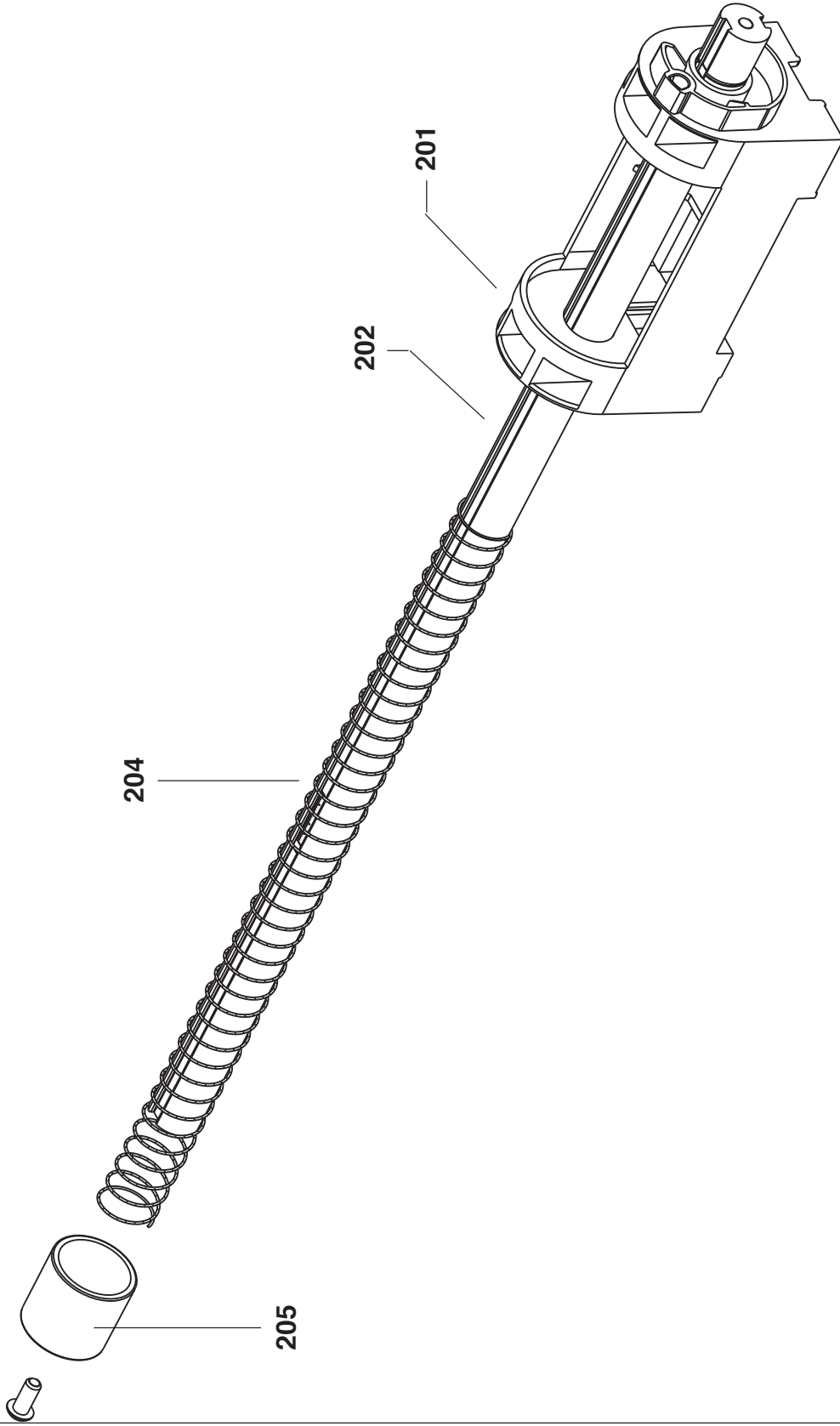



200	5-104342	TASTATORE MANUALE	MANUAL FEELER
201	4-108592	SUPPORTO	SUPPORT
202	5-104662	ASTA+TARGHETTA	ROD+LABEL
204	4-108611	MOLLA	SPRING
205	4-108594	BOCCOLA	BUSHING

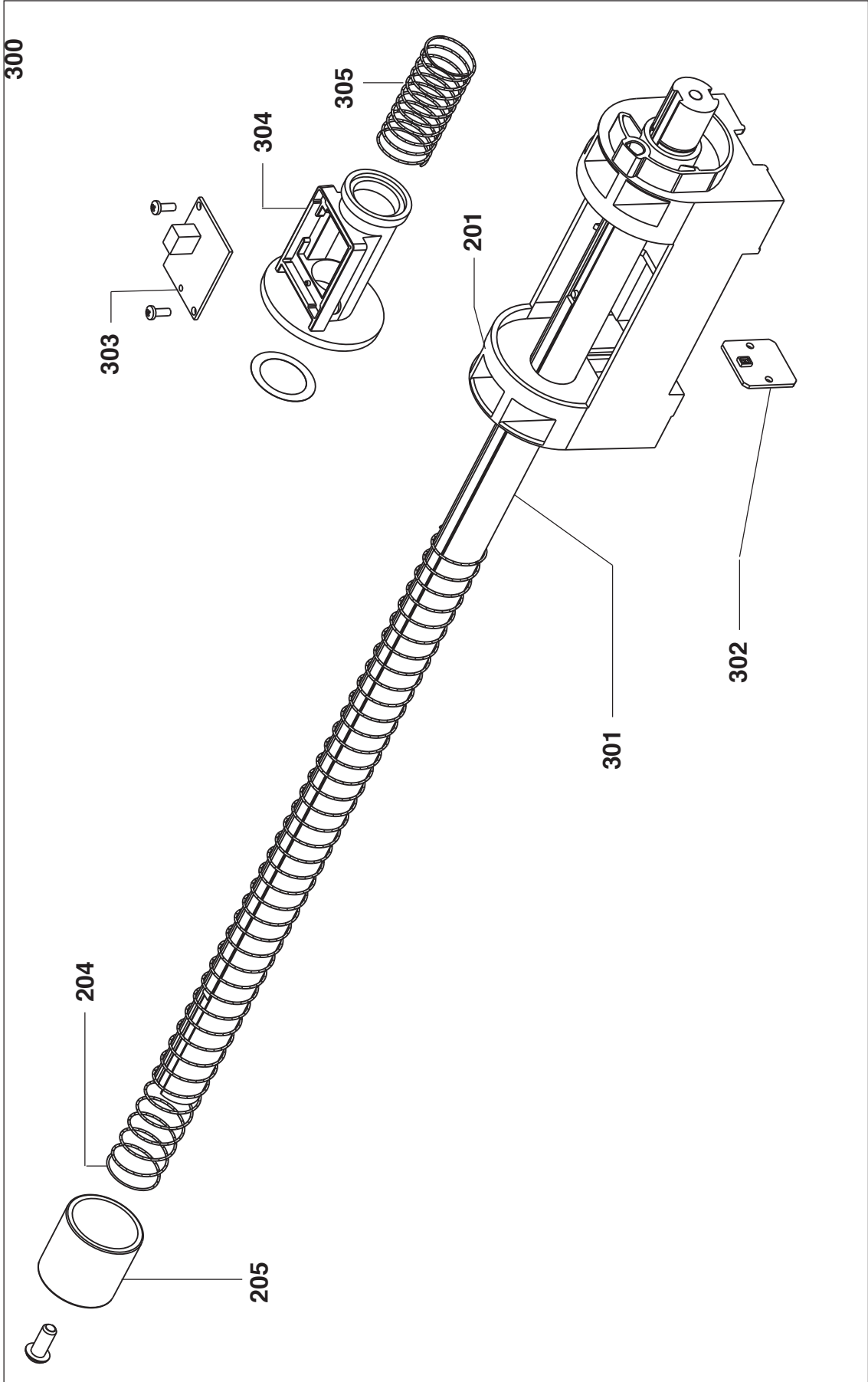

300

300	5-100965	TASTATORE DIGITALE	DIGITAL FEELER
201	4-108592	SUPPORTO	SUPPORT
204	4-108611	MOLLA	SPRING
205	4-108594	BOCCOLA	BUSHING
301	5-103203	ASTA+MAGNETI+TARGHETTA	STAFF+MAGNET+LABEL
302	5-103204	SCHEDA ENCODER	ENCODER BOARD
303	5-103205	SCHEDA MAGNETI	BOARD
304	4-108799	SUPPORTO+ENCODER	SUPPORT+ENCODER
305	4-108612	MOLLA	SPRING

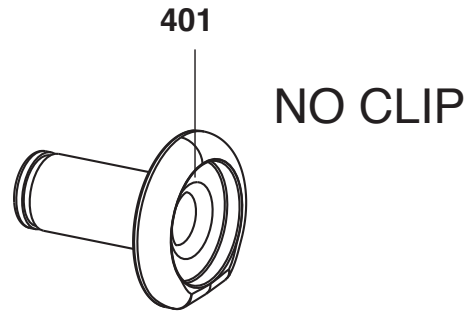
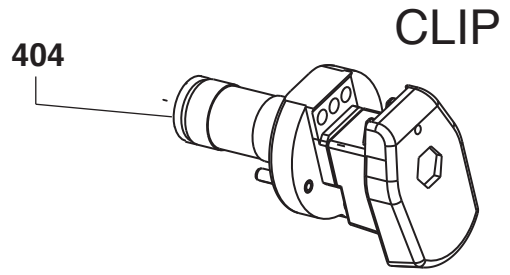
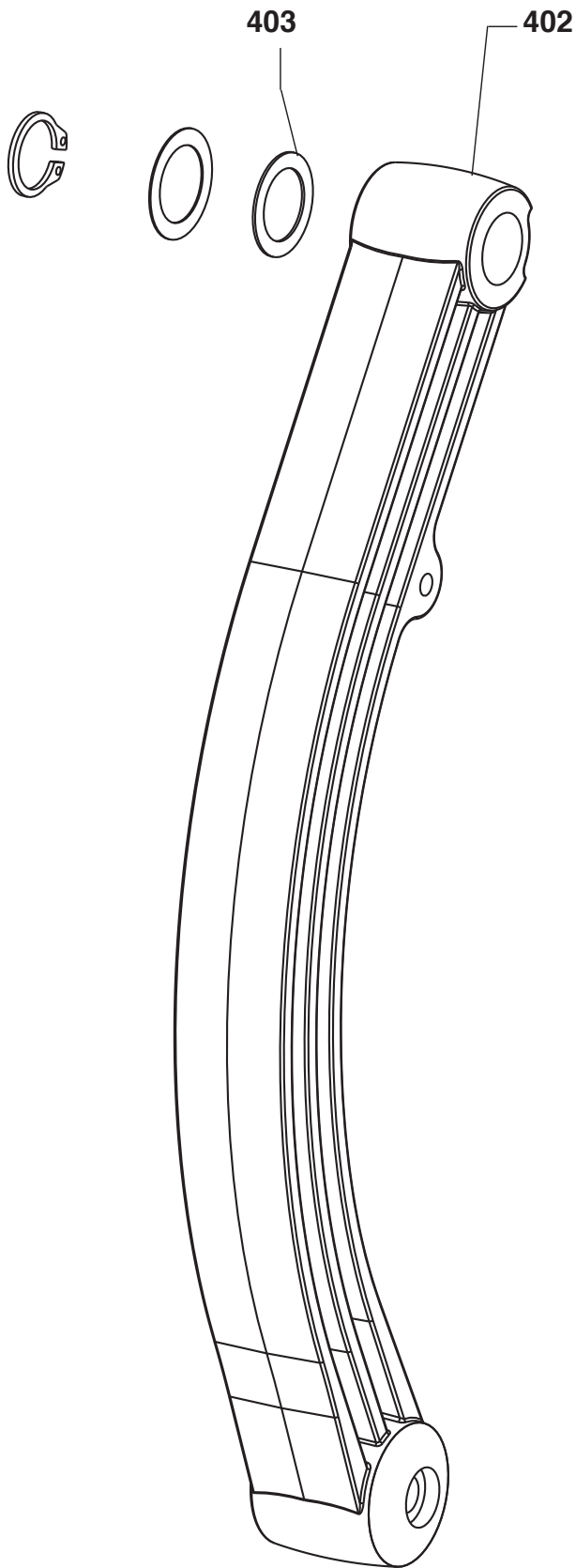

S 62 - S 63 - S 65

0401 4-108607 MANINA NO CLIP  
0402 4-108606 LEVA RILEVATORE  
0403 450073 ANELLO  
0404 5-101462 TERMINALE CLIP

TERMINAL NO CLIP  
LEVER  
RING  
TERMINAL CLIP

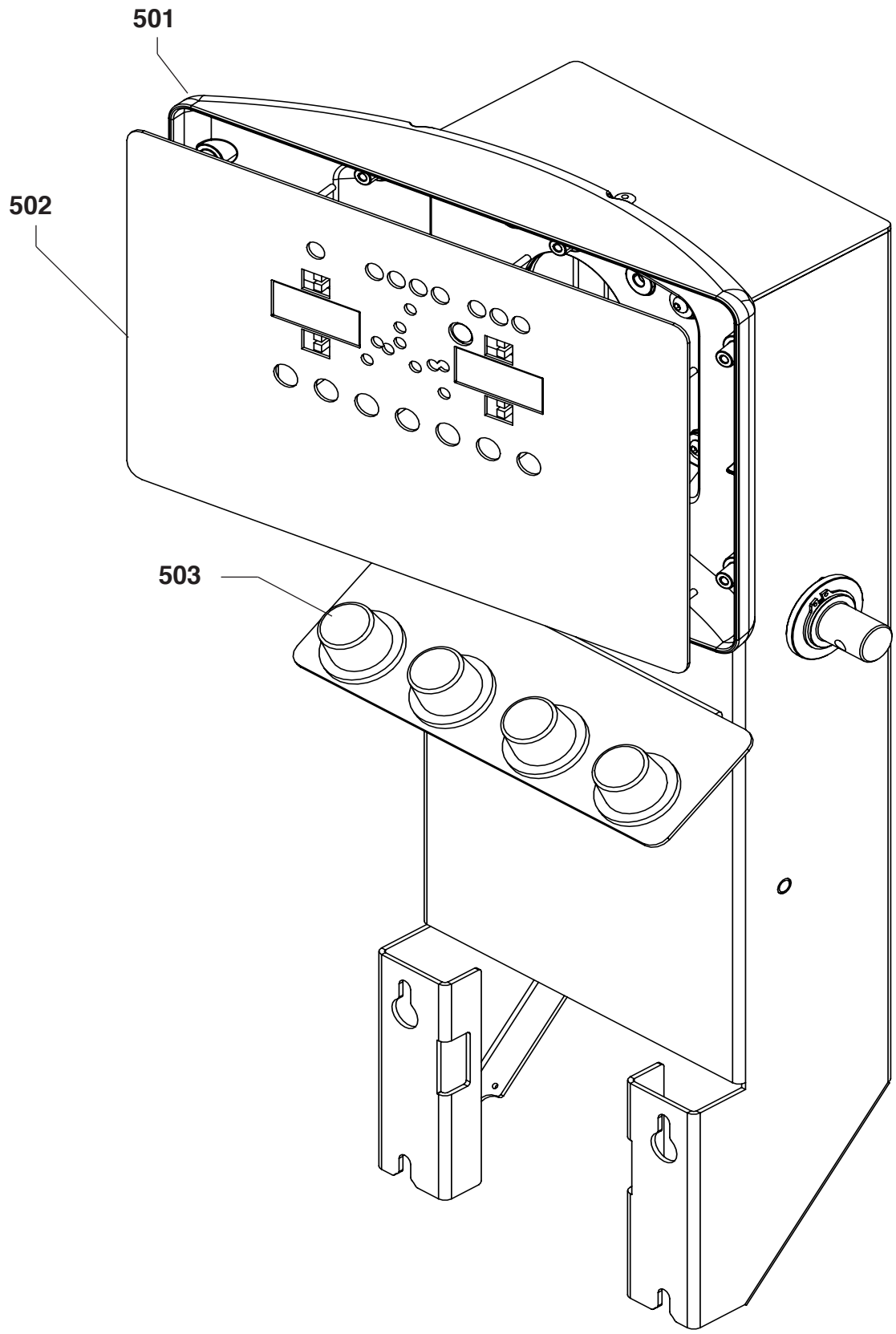

501 4-406647  
502 4-114194  
503 441224

CONSOLLE  
PANNELLO TASTIERA  
PORTACONI

CONSOLLE  
KEYBOARD PANEL  
CONES SUPPORT

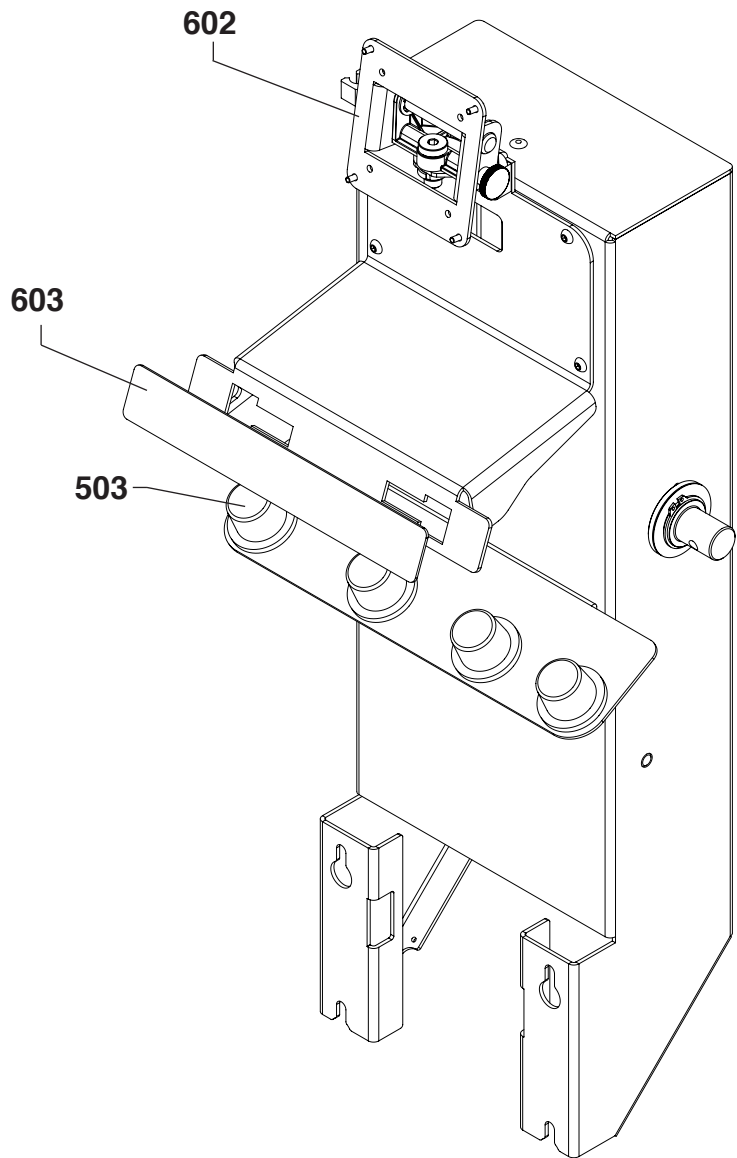
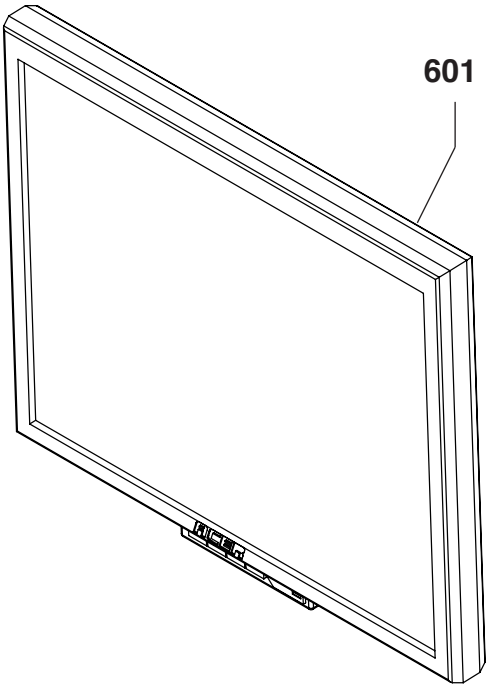



503	441224	PORTACONI
601	4-103594	MONITOR 17"
601	3-01952	MONITOR 19"
602	5-103706	SUPPORTO MONITOR
603	5-103707	TASTIERA

CONES SUPPORT
MONITOR 17"
MONITOR 19"
MONIITOR SUPPORT
KEYBOARD

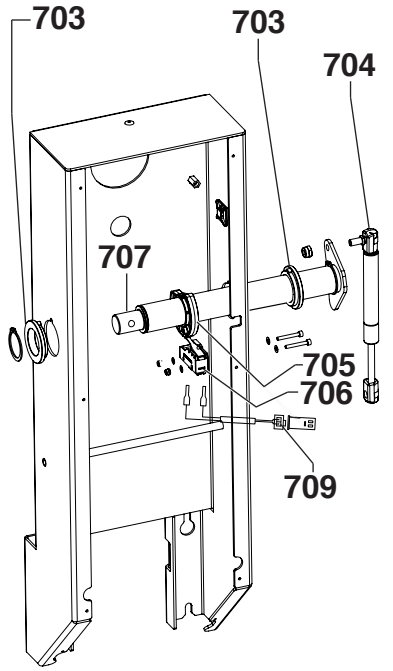
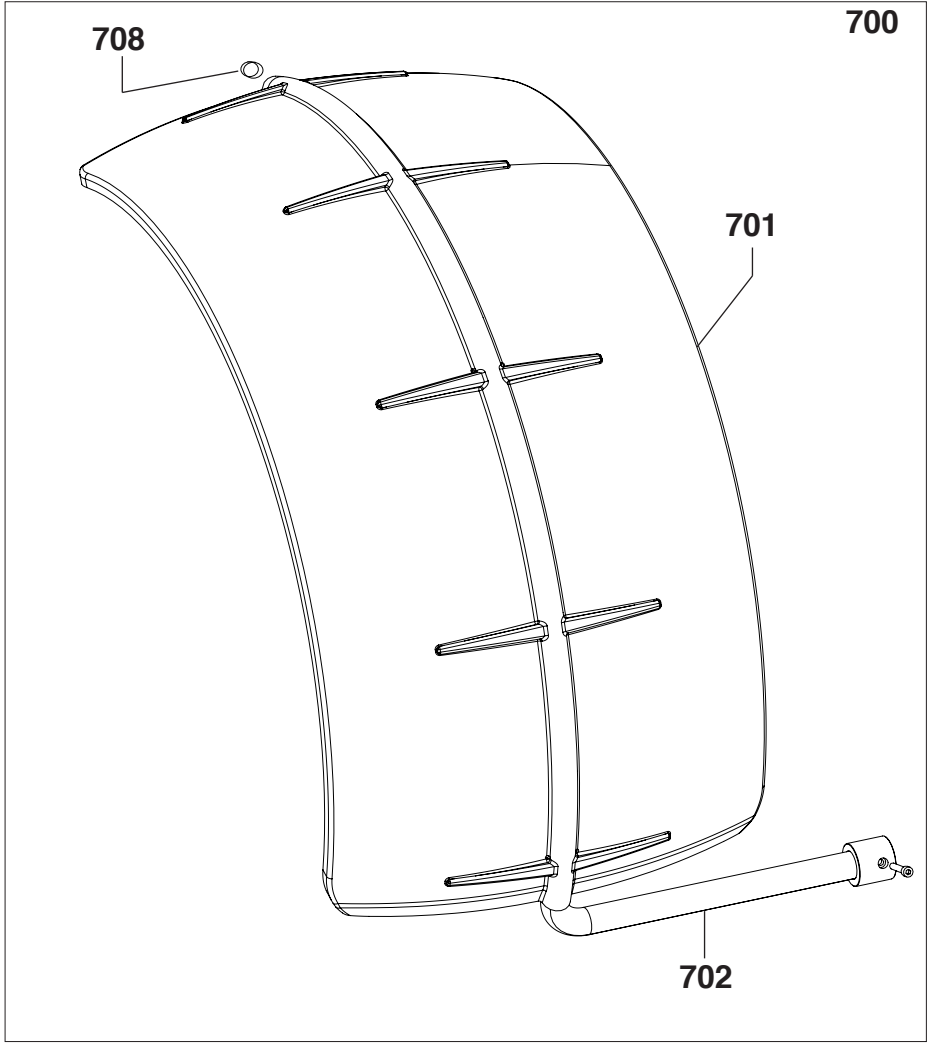

700	5-103705	PROTEZIONE RUOTA CPL
701	4-406533	PROTEZIONE RUOTA
702	4-103499	SUPPORTO PROTEZIONE
703	4-400288	BOCCOLA
704	4-103662	MOLLA A GAS
705	4-104570	CAMMA
706	4-109005	MICRO
707	4-103092	PERNO
708	3-90225	TAPPO
709	4-109501	CAVO

KIT WHEEL PROTECTION
WHEEL PROTECTION
SUPPORT
BUSHING
GAS SPRING
CAM
MICRO
PIN
PLUG
CABLE

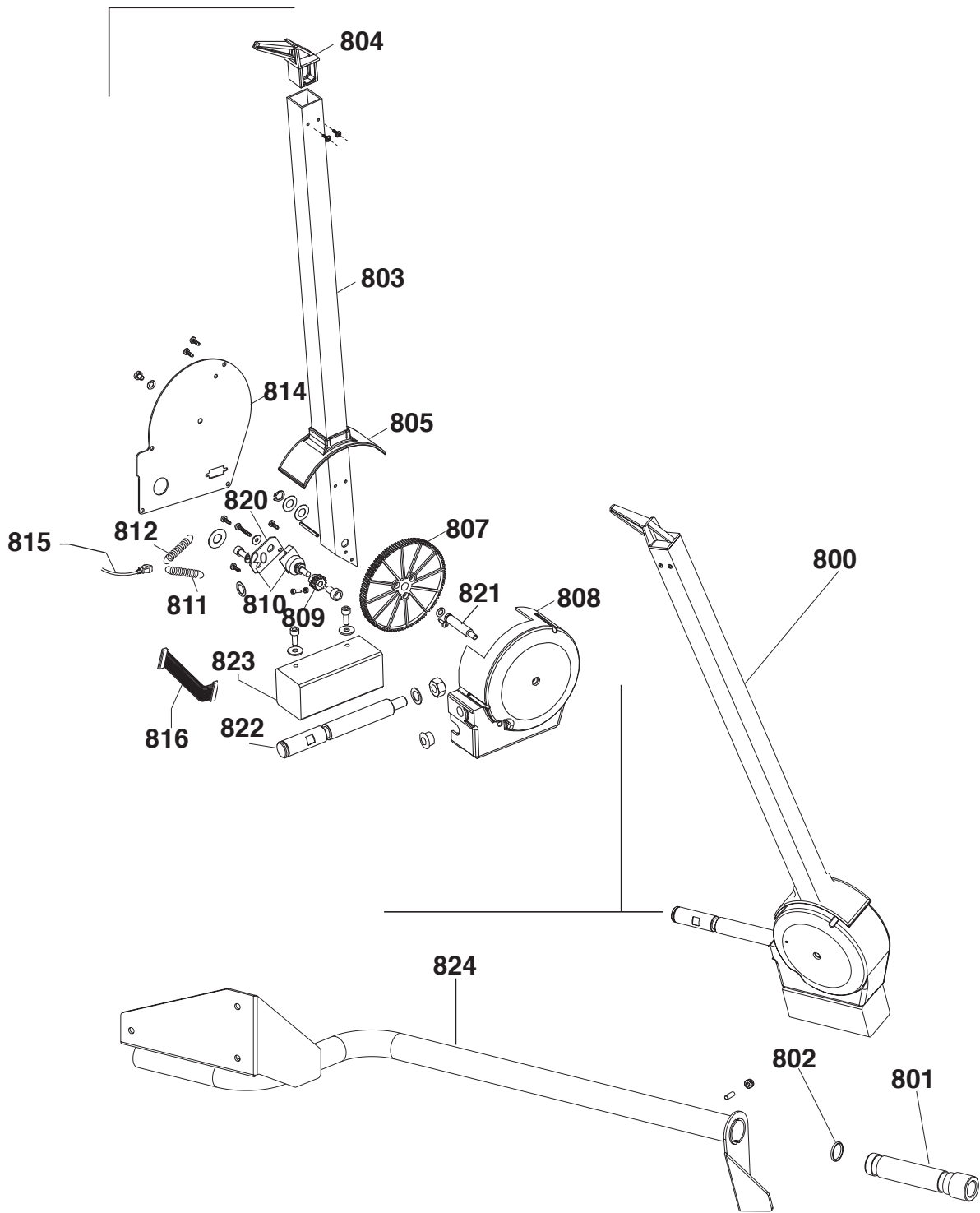

800	257670	RILEVATORE	SIGNAL TRACER
801	4-104994	BOCCOLA	BUSHING
802	421590	GUARNIZIONE	GASKET
803	353559	BRACCIO	ARM
804	453572	TASTATORE	FEELER PIN
805	454458	PROTEZIONE	SHIELD
807	453579	INGRANAGGIO	GEAR
808	454457	CORPO	BODY
809	449326	PIGNONE	PINION
810	5-101455	POTENZIOMETRO	POTENTIOMETER
811	455120	MOLLA	SPRING
812	454239	MOLLA	SPRING
814	4-106072	COPERCHIO	LID
815	4-106012	CONNETTORE	CONNECTOR
816	4-106036	CAVO	CABLE
820	353573	LAMIERA POTENZIOMETRO	PROTECTION
821	353574	PERNO	PIN
822	353575	PERNO	PIN
823	353577	CONTRAPPESO	POIND
824	4-104813	SUPPORTO TASTATORE	SUPPORT

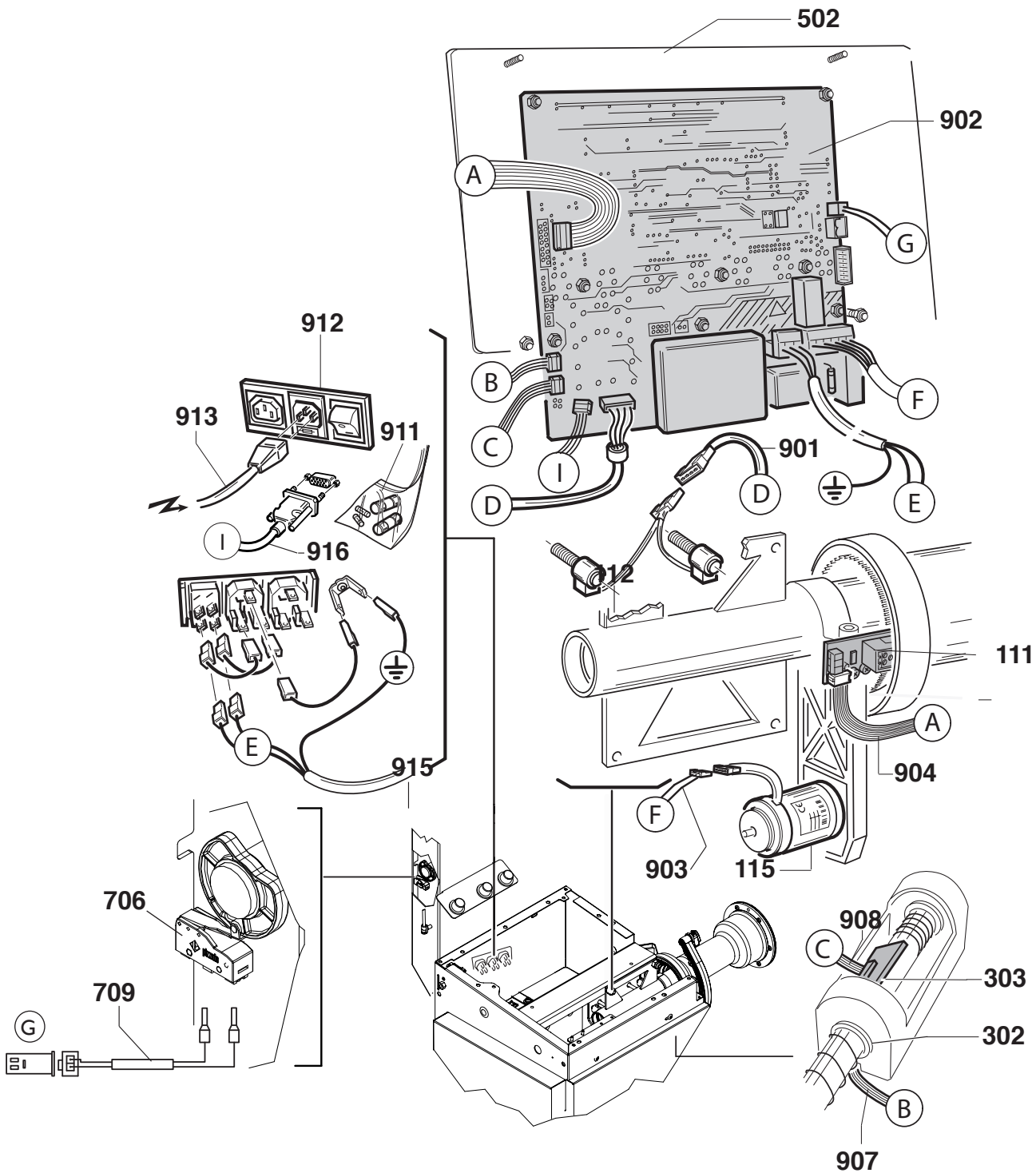

0111	5-101447	SCHEDA ENCODER	ENCODER BOARD
0112	5-103533	PICK-UP	PICK-UP
0115	5-103200	MOTORE AC 230V+PULEGGIA	MOTOR+PULLEY
0115	5-103201	MOTORE AC 115V+PULEGGIA	MOTOR+PULLEY
0302	5-103204	SCHEDA ENCODER	ENCODER BOARD
0303	5-103205	SCHEDA MAGNETI	MAGNETS BOARD
0502	4-407109	PANNELLO TASTIERA	KEYBOARD PANEL
0706	4-109005	MICRO	MICRO
0709	4-109501	CAVO	CABLE
0901	4-109787	CAVO PROLUNGA PICK UP	CABLE
0902	5-103206	SCHEDA EL .+SW	BOARD+SW
0903	4-109820	CAVO PROLUNGA MOTORE	CABLE
0904	4-109785	CAVO FLAT 8 VIE	FLAT CABLE
0907	4-109760	CAVO FLAT 4 VIE	FLAT CABLE
0908	4-109761	CAVO FLAT 6 VIE	FLAT CABLE
0911	5-102043	KIT 3 FUSIBILI 8AT	FUSE KIT
0912	3-01941	INTERRUTTORE	SWITCH
0913	3-01943	CAVO RETE	CABLE
0915	4-109786	CAVO ALIM.	CABLE
0916	462711	CAVO FLAT 3 POLI	FLAT CABLE

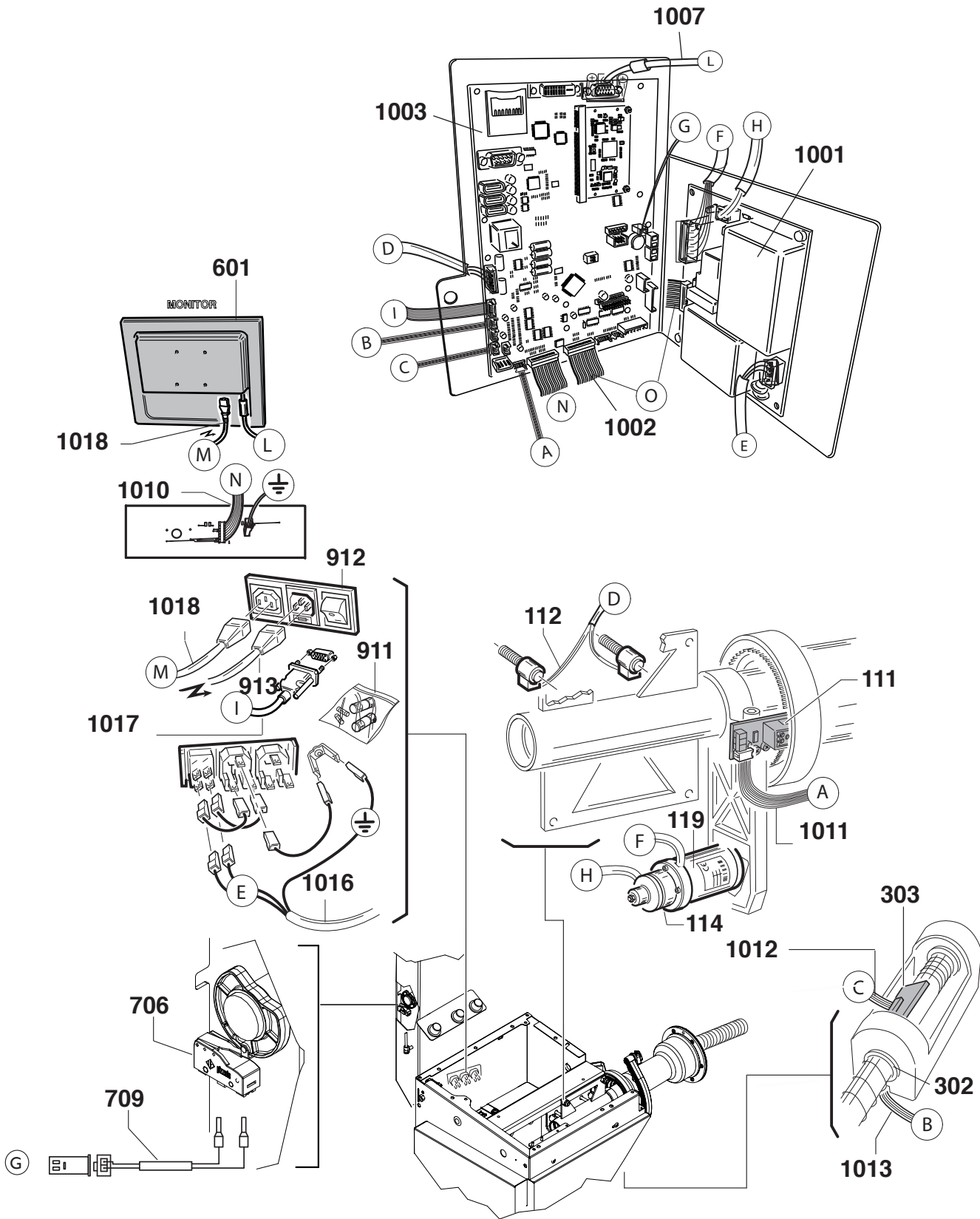



0111	5-101447	SCHEDA ENCODER	ENCODER BOARD
0112	5-103533	PICK-UP	PICK-UP
0114	5-103692	FRENO+MOZZO	BRAKE
0119	5-100172	MOTORE AC230+PULEGGIA	MOTOR+PULLEY
0119	5-100180	MOTORE AC115+PULEGGIA	MOTOR+PULLEY
0302	5-103204	SCHEDA ENCODER	ENCODER BOARD
0303	5-103205	SCHEDA MAGNETI	MAGNETS BOARD
0601	4-103594	MONITOR 17"	MONITOR 17"
0601	3-01952	MONITOR 19"	MONITOR 19"
0706	4-109005	MICRO	MICRO
0709	4-109501	CAVO	CABLE
1001	5-100117	SCHEDA ALIMENTATORE	POWER BOARD
1002	4-109502	CAVO FLAT 18 VIE	FLAT CABLE
<b>1003</b>	<b>5-105851</b>	<b>SCHEDA CPU</b>	<b>CPU BOARD</b>
1007	4-106133	CAVO PROLUNGA	CAVO PROLUNGA
1010	4-104684	CAVO FLAT 16 VIE	FLAT CABLE
1011	449319	CAVO FLAT 8 VIE	FLAT CABLE
1012	4-109588	CAVO FLAT 6VIE	FLAT CABLE
1013	4-109587	CAVO FLAT 4 VIE	FLAT CABLE
1016	4-108093	CAVO WLIMENTAZIONE	POWER CABLE
1017	455181	CAVO	CABLE
1018	3-01942	CAVO MONITOR	CABLE

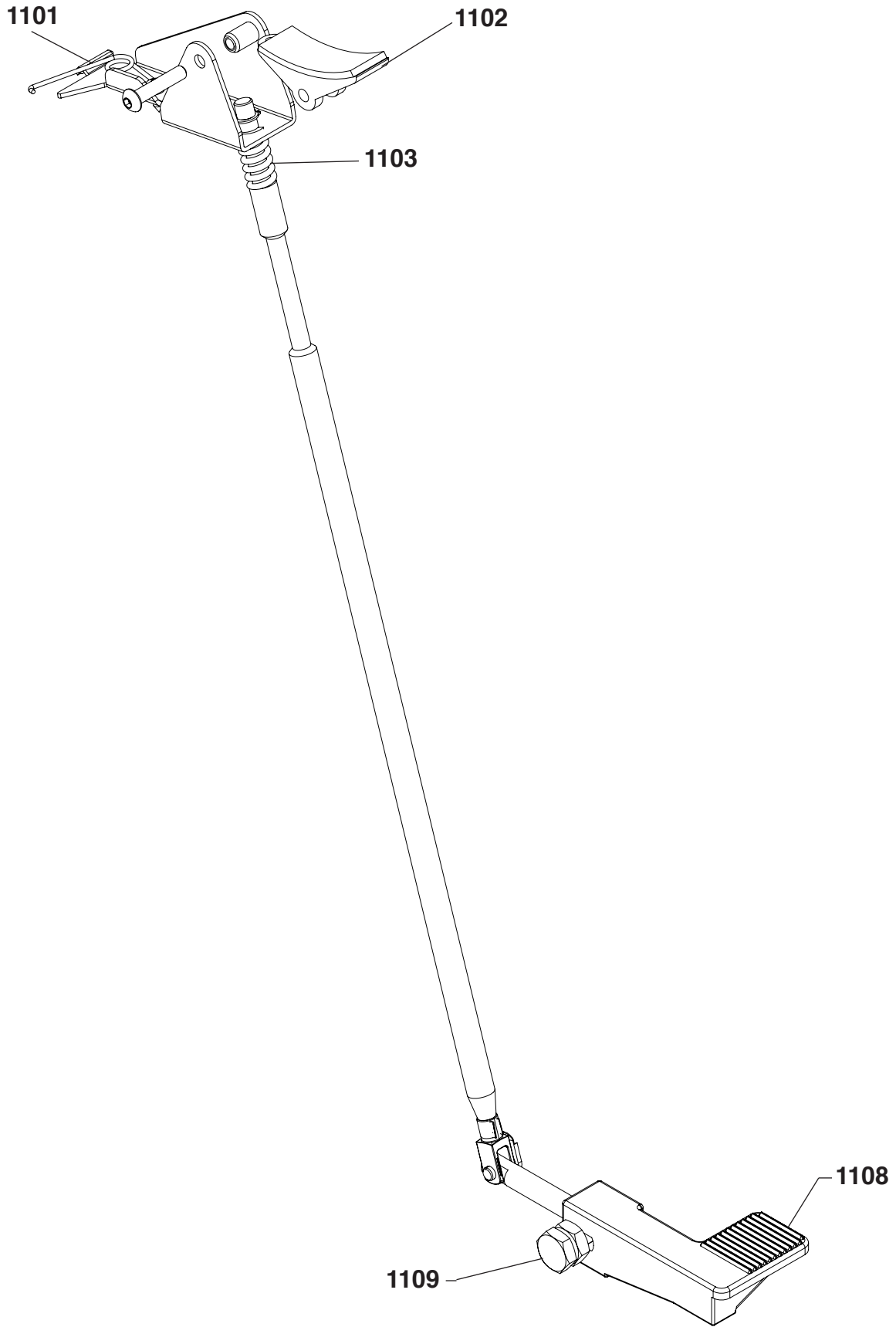

1101	4-110623	MOLLA
1102	4-102639	PATTINO
1103	4-103659	MOLLA
1108	4-103647	PEDALE
1109	4-110038	FULCRO PEDALE

SPRING
PAD
SPRING
PEDAL
PEDAL PIN



**SICE**  
**AUTOMOTIVE EQUIPMENT**

SOCIETA' ITALIANA COSTRUZIONI ELETTROMECCANICHE S.I.C.E. - S.p.A.  
Via Modena, 34 - 42015 CORREGGIO (R.E.) - ITALY  
Tel. (0522) 693640 Export dept.: Tel. (059) 348611  
Fax (0522) 642882 Fax (059) 359358  
E-mail: sice@sice.it Internet: <http://www.sice.it> E-mail: [sice@atlantesrl.com](mailto:sice@atlantesrl.com)