

**Gru standard** STD Crane Grue standard - Standardcrane - Grúa standard

- **Bracci stabilizzatori standard** mm. **5500**  
*Std outrigger booms - Standardstützarme - Bras de stabisation std. - Brazos estabilizadores std.*
- **Angolo di rotazione** **365°**  
*Slewing angle - Angle de rotation - Schwenkbereich - Giro*
- **Tiranti di ancoraggio (Kg. 15)** n° **6 M18 x 1,5** mat. 39 Ni Cr Mo3.  
*Tierods about anchorage - Ancrage - Zugstangen verankerbühör - Tirantes de fijacion*
- **Portata raccomandata** l/min. **20**  
*Recommended oil flow - Débit recommandé - Empfohlene Fördermenge - Caudal requerido*
- **Capacità del serbatoio** litri **30**  
*Tank capacity - Capacité du reservoir - Tankinhalt - Capacidad del deposito de aceite*
- **Pressione massima** bar. **250**  
*Rated pressure - Pression maxi - Betriebsdruck - Presion maxima*

**HC 80 A4 BC**

**Massa della gru senza olio nel serbatoio**

*Overhung crane without oil in the tank - Poids de la grue sans oil reservoir  
Gewichte des kranes ohne öl im tank - Peso de la grua sin aceite en el deposito*

**Kg. 850**

**Momento di sollevamento massimo**

*Maximum lifting moment - Moment de levage maxi  
Max. Lastmoment - Momento de elevacion maxima*

**t m 5.8**

**Sbraccio oleodinamico**

*Maximum hydraulic reach - Allongement hydraulique  
Hydraulische Reichweite - Alcance hidraulico*

- **ORIZZONTALE** - Horizontal - Horizontal - Horizontal - Horizontal

- **VERTICALE** - Vertical - Vertical - Vertikal - Vertical

**m. 8.75**

**m. 11.9**

**Sbraccio con prolunghe**

*Maximum reach with manual exstensions - Allongement avec rallonges manuelles  
Reichweite, manuelle Verlängerungen - Alcance con prolongas manuale*

- **ORIZZONTALE** - Horizontal - Horizontal - Horizontal - Horizontal

- **VERTICALE** - Vertical - Vertical - Vertikal - Vertical

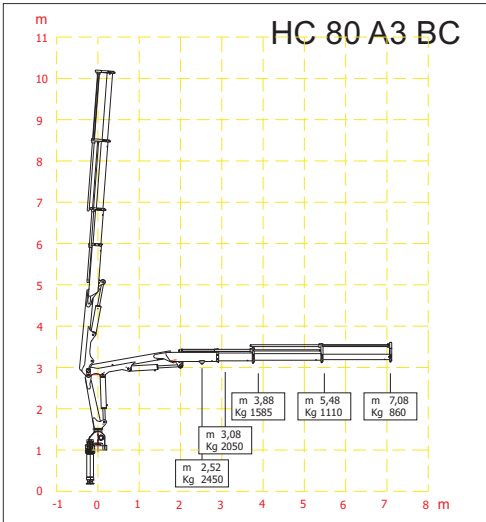
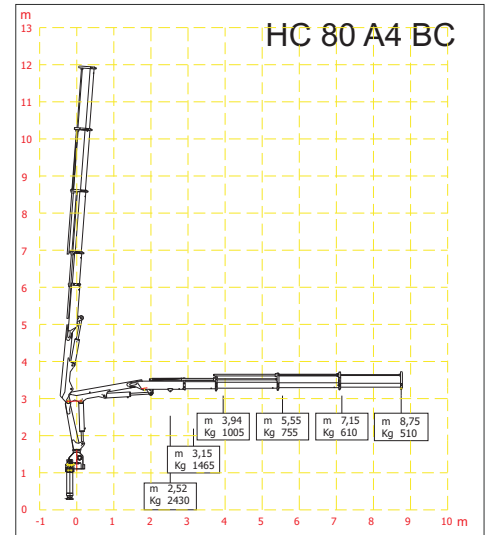

**HC 80 A3 BC**

**Massa della gru senza olio nel serbatoio**

*Overhung crane without oil in the tank - Poids de la grue sans oil reservoir  
Gewichte des kranes ohne öl im tank - Peso de la grua sin aceite en el deposito*

**Kg 830**

**Momento di sollevamento massimo**

*Maximum lifting moment - Moment de levage maxi  
Max. Lastmoment - Momento de elevacion maxima*

**tm 6.3**

**Sbraccio oleodinamico**

*Maximum hydraulic reach - Allongement hydraulique  
Hydraulische Reichweite - Alcance hidraulico*

- **ORIZZONTALE** - Horizontal - Horizontal - Horizontal - Horizontal

- **VERTICALE** - Vertical - Vertical - Vertikal - Vertical

**m 7.08**

**m 10.1**

**Sbraccio con prolunghe**

*Maximum reach with manual exstensions - Allongement avec rallonges manuelles  
Reichweite, manuelle Verlängerungen - Alcance con prolongas manuale*

- **ORIZZONTALE** - Horizontal - Horizontal - Horizontal - Horizontal

- **VERTICALE** - Vertical - Vertical - Vertikal - Vertical

# HC 80 A4 BC

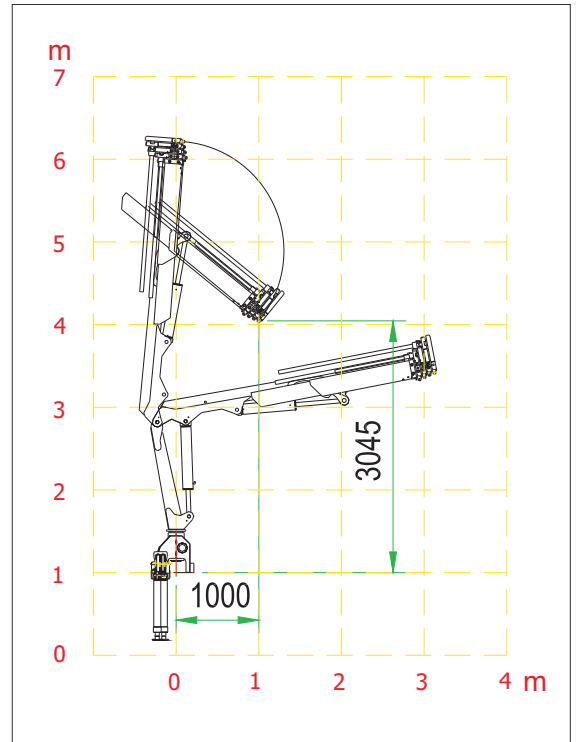
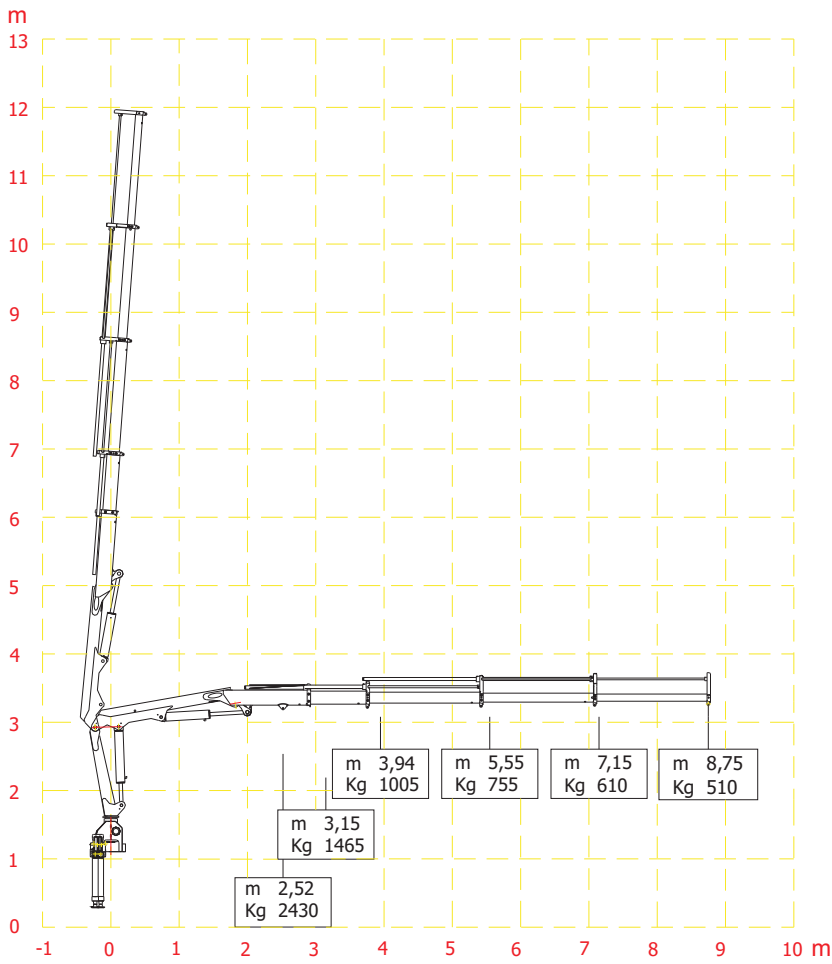

# HC 80 A3 BC

