

APPROVALS



 **ENGINEERING CODE**
923EA04

 **APPROVED REFRIGERANT**
R-404A

 **POWER SUPPLY**
220-240 V 50 Hz

 **STANDARD CONDITIONS**
ASHRAE

 **APPLICATION**
LBP

 **COOLING CAPACITY**
1076 W (LBP)

 **EFFICIENCY**
1.45 W/W (LBP)

 **MOTOR TYPE**
CSCR

 **STARTING TORQUE**
HST

DATA

General Data

Type	Hermetic reciprocating
Technology Type	On-Off
Displacement	22.37 cm ³
Compressor Cooling	Fan/NotControlled/220
Fan Air Flow	520 m ³ /h
Expansion Device	Capillary Tube or Expansion Valve
Horse Power	1 hp
Max Condensing Pressure Operating	24.71 bar
Max Condensing Pressure Peak	27.71 bar
Power Supply	220-240 V 50 Hz
Evaporating Temperature Range	-40 °C to -10 °C

Electrical Data

Motor type	CSCR
Starting Torque	HST
Start Winding Resistance	8.4 Ω at 25° C
Run Winding Resistance	1.9 Ω at 25° C

Mechanical Data

Maximum Recommended Refrigerant Charge	800 g
Oil Charge	450 ml
Oil Type Configuration	ESTER
Oil Type Viscosity	ISO22
Pressurization	Dry air charge
Weight	17.5 Kg
Free Internal Volume	3.3 L

Electrical Components

	Description
Run Capacitor	15
CSR / CSIR Box	YES
Starting Device	RVA3N3C-122
Motor Protection	MST26AHK-3261
Start Capacitor	130-156 Uf / 250 V

External Characteristics

Base Plate	Universal	
Tray Holder	No	
Height	234 mm	
Connector	Internal Diameter	Shape
Suction	9.6 mm	Vertical/Copper
Discharge	6.42 mm	Vertical/Copper
Process	6.42 mm	Vertical/Copper

PERFORMANCE

Rated Points

Condensing Temperature	Evaporating Temperature	Cooling Capacity	Power Consumption	Current	Gas Flow Rate	Efficiency
54.40°C	-23.30°C	1076 W	742 W	3.45 A	24.89 kg/h	1.45 W/W

Test Condition: ASHRAELBP32, Fan/NotControlled/220, Return Gas 32.2°C, Evaporation -23.30°C, Condensing 54.40°C, Ambient 32.2°C, Liquid 32.2°C, Subcooling 22.2K. Data in accordance to EN

12900:2013 and AHRI 540:2015 polynomial equation and uncertainty guidance.

Performance Curve Data

Condensing Temperature 35°C

Evaporating Temperature °C	Cooling Capacity W	Power W	Current A	Gas Flow Rate kg/h	Efficiency W/W
-40	494	425	2.21	11.33	1.16
-35	664	495	2.45	15.28	1.34
-30	881	566	2.72	20.33	1.56
-25	1143	636	3.03	26.50	1.8
-20	1452	707	3.38	33.84	2.05
-15	1807	778	3.76	42.36	2.32
-10	2207	848	4.18	52.09	2.6

Test Condition: ASHRAELBP32, Fan/NotControlled/220, Return Gas 32.2°C, Ambient 32.2°C, Liquid 32.2°C. Data in accordance to EN 12900:2013 and AHRI 540:2015 polynomial equation and uncertainty guidance.

Condensing Temperature 45°C

Evaporating Temperature °C	Cooling Capacity W	Power W	Current A	Gas Flow Rate kg/h	Efficiency W/W
-35	615	507	2.5	14.12	1.21
-30	823	593	2.83	18.96	1.39
-25	1075	679	3.18	24.88	1.58
-20	1372	766	3.56	31.90	1.79
-15	1712	852	3.97	40.05	2.01
-10	2095	939	4.4	49.36	2.23

Test Condition: ASHRAELBP32, Fan/NotControlled/220, Return Gas 32.2°C, Ambient 32.2°C, Liquid 32.2°C. Data in accordance to EN 12900:2013 and AHRI 540:2015 polynomial equation and uncertainty guidance.

Condensing Temperature 55°C

Evaporating Temperature °C	Cooling Capacity W	Power W	Current A	Gas Flow Rate kg/h	Efficiency W/W
-30	740	609	2.93	17.02	1.21
-25	981	708	3.32	22.66	1.39
-20	1265	807	3.74	29.36	1.57
-15	1590	906	4.17	37.13	1.76
-10	1957	1006	4.61	46.01	1.95

Test Condition: ASHRAELBP32, Fan/NotControlled/220, Return Gas 32.2°C, Ambient 32.2°C, Liquid 32.2°C. Data in accordance to EN 12900:2013 and AHRI 540:2015 polynomial equation and uncertainty guidance.

Operating Envelope



External Dimensions

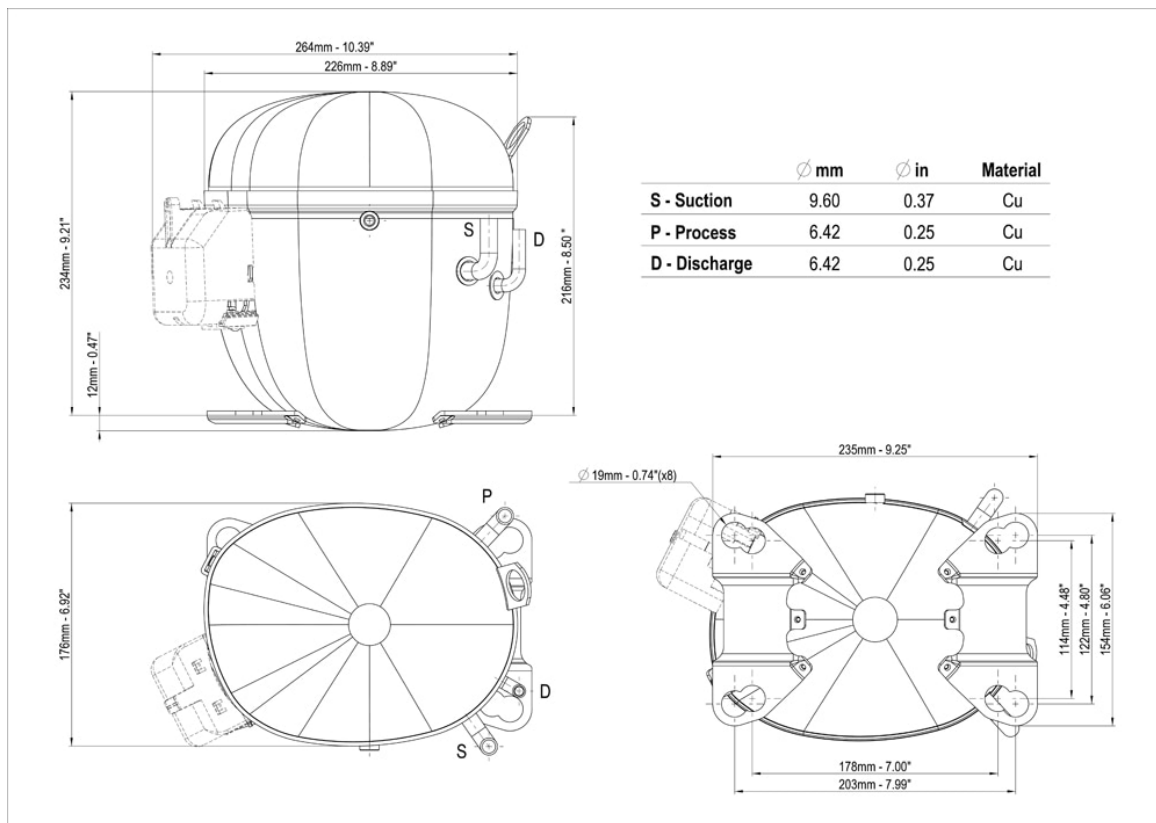

Wiring Diagram

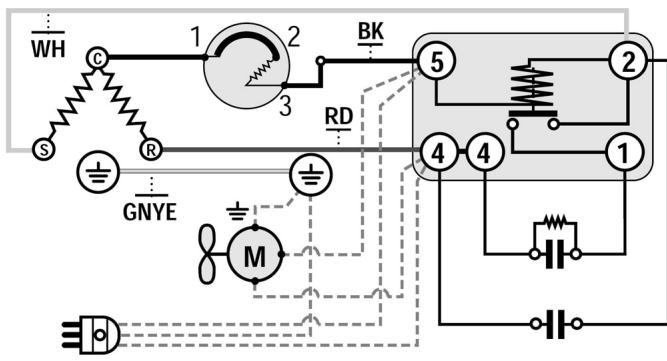

Assembly Instructions

