



**APPROVALS**



**ENGINEERING CODE**  
513306216

**APPROVED REFRIGERANT**  
R-404A

**POWER SUPPLY**  
220-240 V 50 Hz

**STANDARD CONDITIONS**  
ASHRAE

**APPLICATION**  
LBP

**COOLING CAPACITY**  
243 W (LBP)

**EFFICIENCY**  
1.32 W/W (LBP)

**MOTOR TYPE**  
CSIR

**STARTING TORQUE**  
HST

**DATA**

**General Data**

Type	Hermetic reciprocating
Technology Type	On-Off
Displacement	4.5 cm <sup>3</sup>
Compressor Cooling	Static/NotControlled/220
Expansion Device	Capillary Tube or Expansion Valve
Horse Power	1/4 hp
Power Supply	220-240 V 50 Hz
Evaporating Temperature Range	-40 °C to -10 °C

**Electrical Data**

Motor type	CSIR
Starting Torque	HST

**Mechanical Data**

Oil Charge	180 ml
Oil Type Configuration	ESTER
Oil Type Viscosity	ISO22
Weight	7.8 Kg

## Electrical Components

	Description
Starting Device	Relay   MTRP-0015*
Start Capacitor	43-53 Uf / 330 V
Motor Protection	T0040/G6

## External Characteristics

Tray Holder	Yes	
Connector	Internal Diameter	Shape
Suction	6.1 mm	Slanted 42°/Copper
Discharge	4.86 mm	Straight/Copper
Process	6.1 mm	Slanted 42°/Copper

## PERFORMANCE

### Rated Points

Condensing Temperature	Evaporating Temperature	Cooling Capacity	Power Consumption	Current	Gas Flow Rate	Efficiency
54.40°C	-23.30°C	243 W	183 W	1.18 A	5.64 kg/h	1.32 W/W

Test Condition: ASHRAELBP32, Static/NotControlled/220, Return Gas 32.2°C, Evaporation -23.30°C, Condensing 54.40°C, Ambient 32.2°C, Liquid 32.2°C, Subcooling 22.2K. Data in accordance to EN 12900:2013 and AHRI 540:2015 polynomial equation and uncertainty guidance.

### Performance Curve Data

Condensing Temperature 35°C

Evaporating Temperature °C	Cooling Capacity W	Power W	Current A	Gas Flow Rate kg/h	Efficiency W/W
-40	122	113	0.99	2.80	1.08
-35	159	127	1.02	3.66	1.25
-30	205	142	1.06	4.73	1.45
-25	262	156	1.11	6.06	1.67
-20	329	171	1.16	7.68	1.92
-15	410	187	1.21	9.61	2.19
-10	504	202	1.26	11.89	2.49

Test Condition: ASHRAELBP32, Static/NotControlled/220, Return Gas 32.2°C, Ambient 32.2°C, Liquid 32.2°C. Data in accordance to EN 12900:2013 and AHRI 540:2015 polynomial equation and uncertainty guidance.

### Condensing Temperature 45°C

Evaporating Temperature °C	Cooling Capacity W	Power W	Current A	Gas Flow Rate kg/h	Efficiency W/W
-40	108	113	0.99	2.48	0.96
-35	146	131	1.03	3.35	1.12
-30	192	149	1.08	4.41	1.29
-25	246	168	1.14	5.70	1.47
-20	312	187	1.2	7.25	1.67
-15	388	206	1.27	9.09	1.88
-10	477	226	1.33	11.25	2.11

Test Condition: ASHRAELBP32, Static/NotControlled/220, Return Gas 32.2°C, Ambient 32.2°C, Liquid 32.2°C. Data in accordance to EN 12900:2013 and AHRI 540:2015 polynomial equation and uncertainty guidance.

### Condensing Temperature 55°C

Evaporating Temperature °C	Cooling Capacity W	Power W	Current A	Gas Flow Rate kg/h	Efficiency W/W
-40	83	110	0.99	1.90	0.76
-35	122	131	1.03	2.80	0.93
-30	168	153	1.09	3.86	1.1
-25	222	175	1.16	5.12	1.27
-20	285	198	1.24	6.62	1.44
-15	359	222	1.32	8.37	1.62
-10	443	245	1.4	10.42	1.81

Test Condition: ASHRAELBP32, Static/NotControlled/220, Return Gas 32.2°C, Ambient 32.2°C, Liquid 32.2°C. Data in accordance to EN 12900:2013 and AHRI 540:2015 polynomial equation and uncertainty guidance.

### Operating Envelope

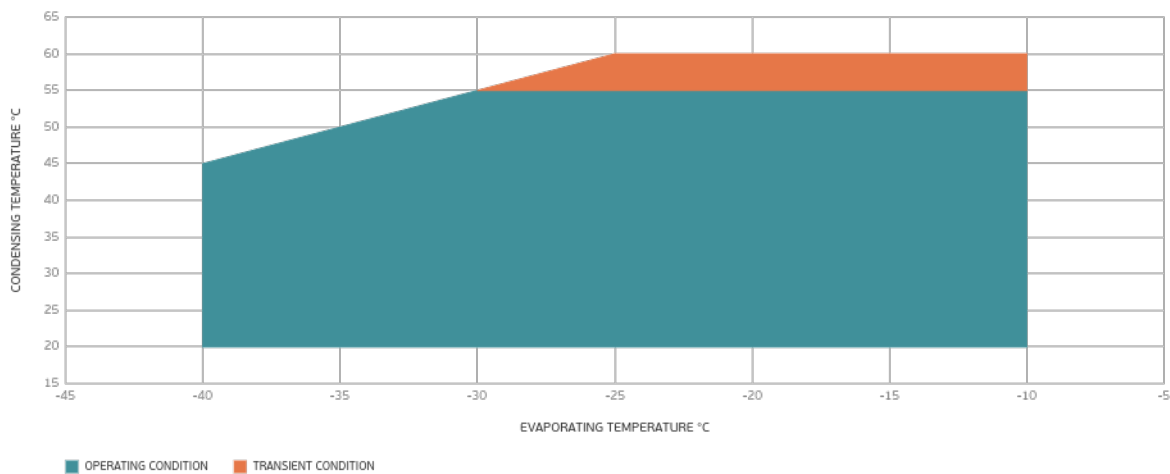

## External Dimensions

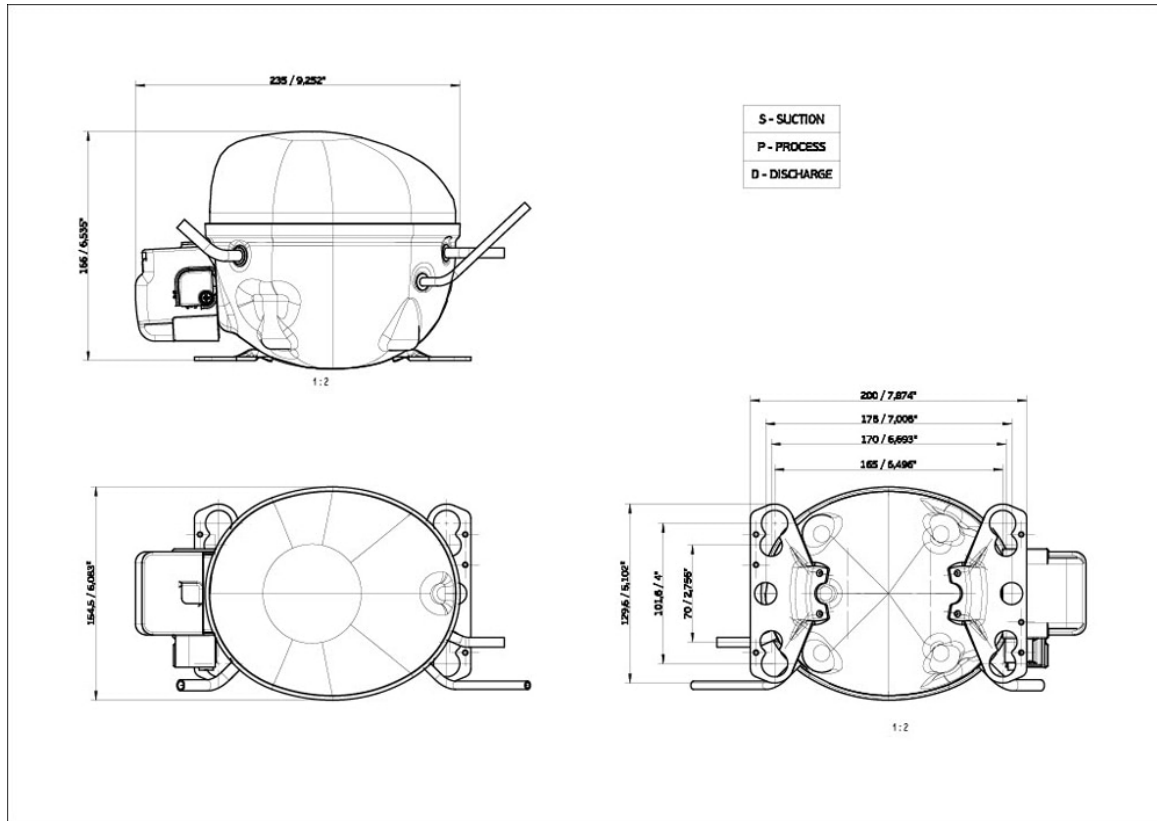

## Wiring Diagram

SM28-4

