

	FLOWDRILL -				FLOWTAP
	Ø	L	Ø	L	Ø
M2	1,8	3200	0,5	2	1600
M3	2,7	3000	0,6	2	1350
M4	3,7	2600	0,7	2	1000
M5	4,5	2500	0,8	2	800
M6	5,4	2400	1,0	2	650
M8	7,3	2200	1,3	2	500
M10	9,2	2000	1,5	3	400
M12	10,9	1800	1,7	3	330
M16	14,8	1400	2,2	4	250
M18	16,7	1300	2,5	5	220
M20	18,7	1200	2,7	5	200
BSP 1/8"	9,2	2000	1,5	3	400
BSP 1/4"	12,4	1600	2,0	3	360
BSP 3/8"	15,9	1400	2,3	4	300
BSP 1/2"	19,9	1200	3,0	5	270
BSP 3/4"	25,4	1000	3,5	6	200
BSP 1"	31,9	800	5,0	9	180

Flowdrill 8, 2
 0,1 6 15%
 50%
 (+1 /)
 10 000
 5 000
FLOWDRILL:
 Flowdrill
 0,1
FLOWTAP:
 2 - 20, G1/16" - G1".
 TiN
 MF / NPT / UNC / UNF / Rp / Rc / BSPP / BSPT / NC / API

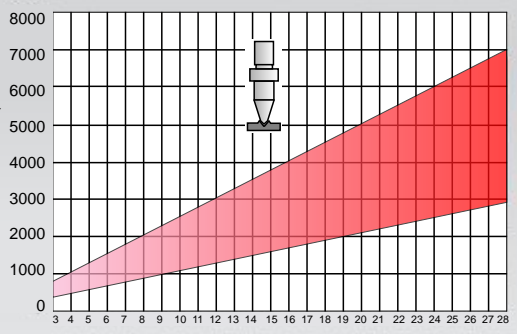

“ ”
 : 056/ 790-06-95 (96)
 : 056/ 790-50-30 (31)
 flowdrill@tppspectr.com.ua

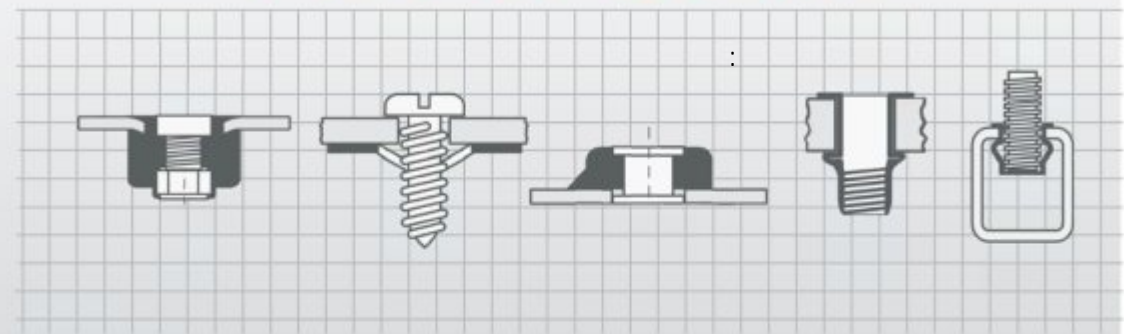
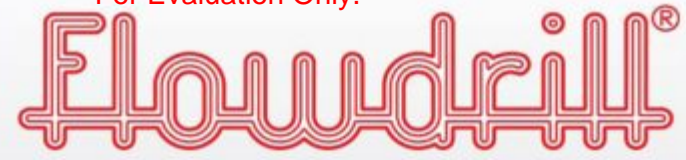
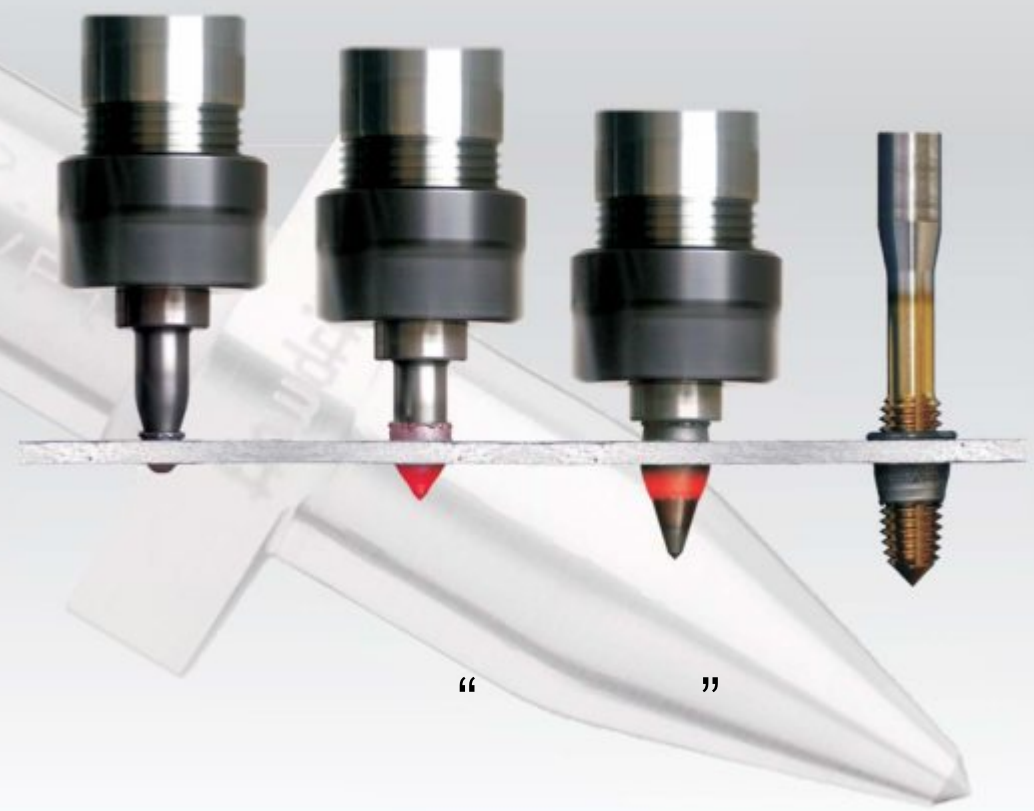

St. Louis, USA Chatham, UK Utrecht, NL Weismen, D

Flowdrill GmbH, Germany Tel.: + 49 6201 29091 0 Fax: + 49 6201 29091 15 info@flowdrill-gmbh.de	Flowdrill B.V., Netherlands Tel.: + 31 30 241 6606 Fax: + 31 30 241 3860 info@flowdrill.nl	Flowdrill (UK) Ltd., United Kingdom Tel.: +44 1634 309 422 Fax: +44 1634 303 306 flowdrill.uk@virgin.net	Flowdrill Inc., USA Tel.: +1 314 968 1134 Fax: +1 314 968 1510 info@flowdrill.com
--	--	--	---

Flowdrill® is the registered trademark of Flowdrill B.V. NL - 3542 Utrecht. Copyright by Flowdrill 10/2008



▶ **Flowdrill -**
Flowdrill



▶ **Flowtap -**
Flowtap

▶ 5



▶ **Flowdrill -**



▶ **Flowtap -**



▶ **StarterSet MC2 -**



▶ **Flow2go -**



«Flow2go»

Flowdrill B.V.

25

Flowdrill.