

THE BRAND: MONITOR AUDIO

Monitor Audio is a British owned and managed global specialist in hi-fi loudspeaker design. For over forty years we've been creating stereo and surround sound systems and a range of sonically matched architectural speakers for ultra discreet high quality sound around the home, outside and in commercial installations.

Whatever your taste and budget, you'll discover a Monitor Audio speaker that answers your desire for great sound. Since hi-fi was in its infancy, we've dedicated all our technical expertise, innovation and craftsmanship to the creation of world-class loudspeakers, which communicate the essence of our brand and reward the people who buy them. We want you to share and enjoy the blend of style, quality, performance and sophistication that makes Monitor Audio unique.

Our success is not simply a matter of excellent sound quality, although expert listeners around the world will testify to that. It's more about how we deliver the sonic superlatives. By consistently refining and applying our technologies, Monitor Audio has become the world's foremost expert in developing metal dome drivers. Metal is not the easiest material to shape, which is why many of our competitors choose paper or plastic. When treated correctly metal offers amazing properties for more life-like sound reproduction.



CONTENTS

INTRODUCTION > P.2

RESIDENTIAL > P.15

FLAGSHIP > P.29

COMMERCIAL > P.33

OUTDOOR > P.35

SUBWOOFERS > P.41

ACCESSORIES > P.45



FROM LEFT TO RIGHT: CP-CT380, CP-WT380, CP-WT380IDC, CP-CT380IDC (NOT TO SCALE)

PRODUCT NAMING SYSTEM

EXAMPLES

CT265-FX

WT380-IDC

APPLICATIONS

C:	IN CEILING
W:	IN WALL
T:	TRIMLESS
CP:	CONTROLLED PERFORMANCE (BACK BOX)
PRO:	COMMERCIAL
CL:	CLIMATE
G:	GARDEN
AW:	ALL WEATHER
SS:	SUPER SLIM

MID / BASS DRIVER TECHNOLOGY

1:	MMP II MID / BASS DRIVER C-CAM TWEETER HIGH FREQUENCY LEVEL SWITCH
2:	C-CAM MID / BASS DRIVER C-CAM TWEETER HIGH FREQUENCY LEVEL SWITCH BOUNDARY COMPENSATION SWITCH 3-WAY IDC MODELS AVAILABLE
3:	C-CAM RST MID / BASS DRIVER C-CAM TWEETER HIGH FREQUENCY LEVEL SWITCH BOUNDARY COMPENSATION SWITCH MID FREQUENCY LEVEL SWITCH
4:	C-CAM RST MID / BASS DRIVER RIBBON TWEETER HIGH FREQUENCY LEVEL SWITCH BOUNDARY COMPENSATION SWITCH MID FREQUENCY LEVEL SWITCH

MID / BASS DRIVER SIZE

20:	2"
30:	3"
40:	4"
50:	5"
60:	6"
65:	6½"
80:	8"

SPECIAL FEATURES

T2:	DUAL TWEETER / DUAL WOUND VOICE COIL BASS DRIVERS / STEREO
FX:	DUAL TWEETER / SURROUND DIPOLE/BIPOLE MODES
LCR:	HORIZONTAL OR VERTICAL USE FOR LEFT, CENTRE OR RIGHT CHANNELS
W:	SUBWOOFER
IDC:	INVERTED DUAL CONCENTRIC TWEETER / MID-BASS MODULE
X:	FULL-SIZE

DRIVERS, TWEETERS & TECHNOLOGY



MMP II DRIVER: Metal Matrix Polymer driver cones have a polypropylene base loaded with metallic particles to offer a rigid and responsive structure. They are manufactured using a sophisticated high-pressure injection process, which modulates cone thickness at critical points to optimise stiffness and consistency, resulting in a superior sonic performance.

MMP II DRIVERS FEATURE IN:

CWT SERIES / CT SERIES / CP SERIES / PRO-IC SERIES



RST TECHNOLOGY: The Rigid Surface Technology (RST) cone profile is inspired by the Japanese art of Origami, which demonstrates how a very light material (like paper) can be strengthened and made more rigid by making small and precise folds on its surface. Developed and perfected using sophisticated computer modelling (Finite Element Analysis), the strengthening effect of RST means that we can use thinner, lighter and more responsive C-CAM cones, which provide speed and accuracy while offering greatly reduced distortion. The RST patterns also help to displace standing waves that can propagate on the cone's surface.

RST TECHNOLOGY FEATURES IN:

CT SERIES / CP SERIES / SOUNDFRAME SERIES



C-CAM DRIVER: Ceramic-Coated Aluminium Magnesium is a material originally developed by the aerospace industry for jet engine components. C-CAM cones have a much higher resistance to bending stress and therefore exhibit much greater fidelity over their entire operating range. C-CAM tweeters and woofers share an audible consistency producing a smooth transition of frequencies and a sense of realism and cohesion in the soundstage.

C-CAM DRIVERS FEATURE IN:

CSS230 / CWT SERIES / CT SERIES / CP SERIES / IN-WALL SUBWOOFER / SOUNDFRAME SERIES / SOUNDBAR SERIES / CLIMATE SERIES / AWC SERIES / CW SERIES / CLG SERIES



RDT II (RIGID DIAPHRAGM TECHNOLOGY 2ND GENERATION):

A composite 'sandwich' structure made from ultra-thin low mass skins, bonded to a honeycomb Nomex® core material. It is very light and very strong, meaning that it can respond with great speed without bending – just like a perfect piston. RDT II uses C-CAM for the front skin, while the rear skin is made from a woven carbon fibre material. We discovered that the new structure reduces distortion by over 8dB above 300Hz, which makes RDT II the lowest distortion cone technology in Monitor Audio's history.

RDT II FEATURE IN:

PL100 II / PL200 II / PL300 II / PL500 II / PLC150 II / PLC350 II



C-CAM GOLD DOME TWEETER: The gold dome tweeter is formed from a ceramic-coated aluminium/magnesium alloy, gold anodised to a specific thickness for ideal stiffness and damping characteristics. The gold dome is thinner, lighter, more rigid and therefore more efficient than domes made from other materials which are prone to distortion in the audio band.

C-CAM GOLD DOME TWEETERS FEATURE IN:

CSS230 / CWT SERIES / CT SERIES / CP SERIES / SOUNDFRAME SERIES / SOUNDBAR SERIES / PRO-IC SERIES / CLIMATE SERIES / AWC SERIES



RIBBON TWEETER: Monitor Audio's proprietary ribbon tweeter design uses an ultra-thin sandwich of C-CAM alloy suspended in a powerful transverse magnetic field of high energy NeFeB rare earth magnets. The ribbon serves as both voice coil and radiating diaphragm, with every part of the ribbon driven directly and simultaneously without energy storage. Having a mass of just 18mg, its diaphragm is able to start and stop in an instant, producing a transient response capable of defining the leading edge and natural harmonic resonance of complex musical sounds. Specified to reach ultra-high frequencies up to an elusive 100 kHz.

RIBBON TWEETERS FEATURE IN:

CP SERIES



MPD (MICRO PLEATED DIAPHRAGM) HIGH FREQUENCY TRANSDUCER: Developed over many months of intensive testing and listening, the MPD High Frequency Transducer is a landmark achievement by the engineering team for Platinum II. It represents an imaginative re-working of an existing technology, transforming a successful idea into an audiophile super-driver, having greater accuracy and efficiency than ever before. Using a new, proprietary low-mass pleated diaphragm with a surface area eight times larger than that of a traditional dome tweeter, the MPD transducer works like a super-fast accordion by rapidly squeezing the pleats to produce a smooth, wide, naturally fast response up to 100kHz. As a result it sounds more lifelike, releasing the high harmonic spectrum of every note without the distortion that blurs definition.

MPD HIGH FREQUENCY TRANSDUCER FEATURE IN:

PL100 II / PL200 II / PL300 II / PL500 II / PLC150 II / PLC350 II



IDC DRIVER MODULE: Employing a unique pivoting Inverted Dual Concentric midrange/tweeter module allows for the speakers to be discreetly positioned and the sound to be directed toward the listening zone. With the IDC module installed, these architectural speakers become true 3-way designs, offering superior performance and flexibility over typical 2-way or fixed angle speakers. An inverted 4" midrange driver provides superior dispersion while enabling the midrange cone and tweeter dome assembly to be set as far forward as possible, allowing a clear acoustic 'sighting' of the desired listening zone and reducing undesirable diffraction effects.

IDC DRIVER MODULES FEATURE IN:

CT SERIES / CP SERIES / SOUNDFRAME SERIES

DRIVERS, TWEETERS & TECHNOLOGY



T2 DUAL TWEETER CONFIGURATION (STEREO): Dual, independent, pivoting 1-inch C-CAM tweeters and dual wound voice coil bass drivers for high performance stereo sound from a single speaker. Ideal for bathrooms, hallways, or any area where space does not allow for stereo pairs.

T2 DESIGN FEATURES IN:
CT SERIES / CLIMATE SERIES / AWC SERIES



ADJUSTABLE RESPONSE CONTROLS: Optimum imaging and set-up are established via pivoting tweeters, pivoting IDC driver modules, high-frequency, midrange-frequency, and/or boundary compensation controls (depending on model). The boundary compensation control provides a gentle midrange roll-off response, while preserving extreme low frequency output when the speaker is placed close to ceiling and wall boundaries.

ADJUSTABLE RESPONSE CONTROLS FEATURE IN:
CWT SERIES / CT SERIES / CP SERIES / SOUNDFRAME SERIES (SF1&SF2 only)



FX DUAL TWEETER CONFIGURATION (SURROUND): For use in di-pole or bi-pole modes, FX speakers are ideal for surround or rear channel use in home cinema applications for a fully immersive experience.

FX DESIGN FEATURES IN:
CT SERIES



TRI-GRIP DOG LEG FIXINGS: This unique 3-position 'dog' style fixing provides a greater contact surface area than other types, whilst saving installation time. The Tri-Grip fixings are made from a tough re-enforced polymer, giving a secure fixing without the risk of over-tightening.

TRI-GRIP DOG LEG FIXINGS FEATURE IN:
CSS230 / CWT SERIES / CT SERIES / CP SERIES / IN-WALL SUBWOOFER / AWC SERIES / PLATINUM SERIES II



TRIMLESS GRILES: A 'stealthy' super-narrow bezel ensure a near-invisible blend between the grille and décor. The grilles attach magnetically to the speaker frame, allowing removal and re-fixing in seconds (except for PRO-80LV & IWS-10 In-Wall subwoofer).

TRIMLESS GRILES FEATURE IN:

CSS230 / CWT SERIES / CT SERIES / CP SERIES / PRO-IC SERIES / IN-WALL SUBWOOFER / AWC SERIES / PLATINUM SERIES II



PAINTABLE GRILES: To further integrate with any décor, Monitor Audio's Custom Install collection provides paintable grilles with nearly all speakers.

PAINTABLE GRILES FEATURE IN:

CSS230 / CWT SERIES / CT SERIES / CP SERIES / PRO-IC SERIES / CLIMATE SERIES / IN-WALL SUBWOOFER / AWC SERIES



SEALED BACK BOXES

These rigid, mineral-filled enclosures provide an ideal air load for the drivers, optimising midrange and bass performance while maintaining sonic consistency regardless of interior wall construction. The back box also retains the bass driver's backwave, limiting the transmission of sound to adjacent rooms.

SEALED BACK BOXES FEATURE IN:

CSS230 / CP SERIES / INWALL SUBWOOFER / SOUNDFRAME SERIES / SOUNDBAR SERIES / CLIMATE SERIES / CLG SERIES / PLATINUM SERIES II

	Category	Application	Model Name	Page	Frequency Response	Impedance	Sensitivity (1W@1m)	Maximum SPL	Power Handling (RMS)	Recommended Amp Requirements	Drivers & Technology	Optional Square Grilles	
RESIDENTIAL	SLIM RANGE	Super Slim	In-Ceiling	CSS230	17	100Hz-30kHz sealed / 85Hz-30kHz open	8Ω	86dB	103.8dBA	Closed back - 40W Opened back - 60W	10 - 60W	3 x 3" C-CAM Driver / 1" C-CAM Tweeter	✓
		Slim	In-Ceiling	CWT140	17	75Hz - 30kHz	6Ω	85dB	102.8dBA	50W	10 - 50W	4" MMP II Driver / 1" C-CAM Tweeter	✓
			In-Ceiling	CWT240	17	75Hz - 30kHz	6Ω	85dB	102.8dBA	50W	10 - 50W	4" C-CAM Driver / 1" C-CAM Tweeter	✓
			In-Ceiling	CWT160	17	60Hz - 30kHz	6Ω	88dB	107.2dBA	70W	15 - 70W	6" MMP II Driver / 1" C-CAM Tweeter	✓
			In-Ceiling	CWT180	17	48Hz - 30kHz	6Ω	90dB	110.6dBA	120W	30 - 120W	8" MMP II Driver / 1" C-CAM Tweeter	✓
	CORE RANGE	CT	In-Ceiling	CT165	18	60Hz - 25kHz	6Ω	88.5dB	107.4dBA	65W	20 - 65W	6 ^{1/2} " MMP II Driver / 1" C-CAM Tweeter	✓
			In-Ceiling	CT180	18	50Hz - 25kHz	6Ω	90dB	111.6dBA	120W	30 - 120W	8" MMP II Driver / 1" C-CAM Tweeter	✓
			In-Ceiling	CT265	18	60Hz - 30kHz	6Ω	88.5dB	108dBA	75W	20 - 75W	6 ^{1/2} " C-CAM Driver / 1" C-CAM Tweeter	✓
			In-Ceiling	CT280	18	50Hz - 30kHz	6Ω	90dB	111.6dBA	120W	30 - 120W	8" C-CAM Driver / 1" C-CAM Tweeter	✓
			In-Ceiling	CT265-IDC	18	60Hz - 30kHz	6Ω	88.5dB	108dBA	85W	20 - 85W	6 ^{1/2} " C-CAM Driver / 4" C-CAM IDC Driver / 1" C-CAM Tweeter	✓
			In-Ceiling	CT280-IDC	19	50Hz - 30kHz	6Ω	90dB	111.6dBA	120W	30 - 120W	8" C-CAM Driver / 4" C-CAM IDC Driver / 1" C-CAM Tweeter	✓
			In-Ceiling	CT380-IDC	19	45Hz - 30kHz	6Ω	90dB	112dBA	150W	40 - 150W	8" C-CAM RST Driver / 4" C-CAM IDC Driver / 1" C-CAM Tweeter	✓
			In-Ceiling	CT265-FX	19	60Hz - 30kHz	6Ω	88.5dB	108dBA	85W	20 - 85W	6 ^{1/2} " C-CAM Driver / 2 x 1" C-CAM Tweeters	✓
			In-Ceiling	CT380-FX	19	45Hz - 30kHz	6Ω	90dB	111.6dBA	120W	30 - 120W	8" C-CAM RST Driver / 2 x 1" C-CAM Tweeters	✓
			In-Ceiling	CT165-T2	19	60Hz - 25kHz	6+6Ω	88.5dB	107.9dBA	65W	20 - 65W	6 ^{1/2} " MMP II Driver / 2 x 1" C-CAM Tweeters	✓
		In-Ceiling	CT180-T2	19	50Hz - 25kHz	6+6Ω	90dB	111.6dBA	120W	30 - 120W	8" MMP II Driver / 2 x 1" C-CAM Tweeters	✓	
		WT	In-Wall	WT165	20	60Hz - 25kHz	6Ω	88.5dB	107.4dBA	65W	20 - 65W	6 ^{1/2} " MMP II Driver / 1" C-CAM Tweeter	-
			In-Wall	WT180	20	50Hz - 25kHz	6Ω	90dB	111.6dBA	120W	30 - 120W	8" MMP II Driver / 1" C-CAM Tweeter	-
	In-Wall		WT265	20	55Hz - 30kHz	6Ω	88.5dB	107.4dBA	65W	20 - 65W	6 ^{1/2} " C-CAM Driver / 1" C-CAM Tweeter	-	
	In-Wall		WT280	20	45Hz - 30kHz	6Ω	90dB	111.6dBA	120W	30 - 120W	8" C-CAM Driver / 1" C-CAM Tweeter	-	
	In-Wall		WT280-IDC	21	45Hz - 30kHz	6Ω	90dB	111.6dBA	120W	40 - 150W	8" C-CAM Driver / 4" C-CAM IDC Driver / 1" C-CAM Tweeter	-	
	In-Wall		WT380-IDC	21	45Hz - 30kHz	6Ω	90dB	112dBA	150W	30 - 120W	8" C-CAM RST Driver / 4" C-CAM IDC Driver / 1" C-CAM Tweeter	-	
	In-Wall		WT150-LCR	21	60Hz - 30kHz	8Ω	88dB	108dBA	100W	30 - 100W	2 x 5" MMP II Drivers / 1" C-CAM Tweeter	-	
	CONTROLLED PERFORMANCE RANGE	CP-CT	In-Ceiling	CPC120	23	100 Hz - 20kHz	8Ω	85dB	101.9dBA	20W (50W using crossover)	5-20W (5-50W using crossover)	2" Micro Driver	-
			In-Ceiling	CP-CT150	23	75Hz - 25kHz	6Ω	85dB	102.8dBA	50W	20 - 50W	5" MMP II Driver / 1" C-CAM Tweeter	✓
			In-Ceiling	CP-CT260	23	66Hz - 25kHz	6Ω	88dB	106.9dBA	65W	20 - 65W	6" C-CAM Driver / 1" C-CAM Tweeter	✓
			In-Ceiling	CP-CT380	23	50Hz - 25kHz	6Ω	89dB	109.6dBA	120W	30 - 120W	8" C-CAM RST Driver / 1" C-CAM Tweeter	✓
			In-Ceiling	CP-CT380IDC	23	50Hz - 30kHz	6Ω	89dB	109.6dBA	120W	30 - 120W	8" C-CAM RST Driver / 4" C-CAM IDC Driver / 1" C-CAM Tweeter	✓
CP-WT		In-Wall	CP-WT150	24	75Hz - 25kHz	6Ω	85dB	102.8dBA	50W	20 - 50W	5" MMP II Driver / 1" C-CAM Tweeter	-	
		In-Wall	CP-WT260	24	65Hz - 25kHz	6Ω	88dB	106.9dBA	65W	20 - 65W	6" C-CAM Driver / 1" C-CAM Tweeter	-	
		In-Wall	CP-WT380	24	50Hz - 25kHz	6Ω	89dB	109.6dBA	120W	30 - 120W	8" C-CAM RST Driver / 1" C-CAM Tweeter	-	
		In-Wall	CP-WT380IDC	24	50Hz - 30kHz	6Ω	89dB	109.6dBA	120W	30 - 120W	8" C-CAM RST Driver / 4" C-CAM IDC Driver / 1" C-CAM Tweeter	-	
		In-Wall	CP-WT140LCR	25	60Hz - 25kHz	6Ω	88dB	108.8dBA	100W	20 - 100W	2 x 4" MMP II Drivers / 1" C-CAM Tweeter	-	
		In-Wall	CP-WT240LCR	25	60Hz - 25kHz	6Ω	88dB	108.8dBA	100W	20 - 100W	2 x 4" C-CAM Drivers / 1" C-CAM Tweeter	-	
		In-Wall	CP-IW260X	25	50Hz - 30kHz	6Ω	89dB	113.8dBA	150W	60 - 150W	2 x 6 ^{1/2} " C-CAM Drivers / 2 x 4" C-CAM Drivers / 1" C-CAM Tweeter	-	
		In-Wall	CP-IW460X	25	50Hz - 60kHz	6Ω	89dB	113.8dBA	150W	60 - 150W	2 x 6 ^{1/2} " C-CAM RST Drivers / 2 x 4" C-CAM RST Drivers / Ribbon Tweeter	-	
INTERIOR DESIGN RANGE	SoundFrame	In-Wall	SF1	26	55Hz - 35kHz	8Ω	86dB	106dBA	100W	20 - 100W	6 ^{1/2} " C-CAM RST Driver / 4" C-CAM IDC Driver / 1" C-CAM Tweeter	-	
		In-Wall	SF2	26	55Hz - 35kHz	8Ω	86dB	106dBA	100W	20 - 100W	6 ^{1/2} " C-CAM RST Driver / 4" C-CAM IDC Driver / 1" C-CAM Tweeter	-	
		In-Wall	SF3	26	75Hz - 35kHz	8Ω	86dB	102.5dBA	50W	20 - 50W	4" MMP II Driver / 1" C-CAM Tweeter	-	
		On-Wall	SF1	26	55Hz - 35kHz	8Ω	86dB	106dBA	100W	20 - 100W	6 ^{1/2} " C-CAM RST Driver / 4" C-CAM IDC Driver / 1" C-CAM Tweeter	-	
		On-Wall	SF2	26	55Hz - 35kHz	8Ω	86dB	106dBA	100W	20 - 100W	6 ^{1/2} " C-CAM RST Driver / 4" C-CAM IDC Driver / 1" C-CAM Tweeter	-	
		On-Wall	SF3	26	75Hz - 35kHz	8Ω	86dB	102.5dBA	50W	20 - 50W	4" MMP II Driver / 1" C-CAM Tweeter	-	

Feature	HF Level Switch (+3dB/0dB/-3dB)	MF Level Switch (+3dB/0dB/-3dB)	Boundary Compensation Switch	Bi pole/ Di pole Switch	Mounting Depth	Cutout Dimensions	Overall Depth (With Grille)	Overall Dimensions (With Grille)	Construction Material	Weight	Pre-Construction Bracket
-	-	-	-	-	2" / 50mm	8 ^{1/4} " / 211mm	2 ^{1/8} " (54mm)	9 ^{13/16} " (250mm)	Mineral Filled ABS Plastic (RoHS2 Compliant)	6lb 5oz (2.88kg)	CB6 (Purple)
-	-	-	-	-	3 ^{7/8} " / 99mm	5 ^{7/8} " / 149mm	4 ^{1/16} " (103.4mm)	Round: 7 ^{7/8} " (180.2mm) Square: 6 ^{15/16} x 6 ^{15/16} " (176.7 x 176.7mm)	Mineral Filled ABS Plastic (RoHS2 Compliant)	2lb 9oz (1.18kg)	CB4 (Pink)
-	-	-	-	-	3 ^{7/8} " / 99mm	5 ^{7/8} " / 149mm	4 ^{1/16} " (103.4mm)	Round: 7 ^{7/8} " (180.2mm) Square: 6 ^{15/16} x 6 ^{15/16} " (176.7 x 176.7mm)	Mineral Filled ABS Plastic (RoHS2 Compliant)	2lb 9oz (1.18kg)	CB4 (Pink)
-	-	-	-	-	3 ^{7/8} " / 99mm	6 ^{11/16} " / 170mm	4 ^{1/16} " (102.8mm)	Round: 8 ^{1/16} " (204.2mm) Square: 7 ^{13/16} x 7 ^{13/16} " (199.2 x 199.2mm)	Mineral Filled ABS Plastic (RoHS2 Compliant)	4lb 10oz (2.10kg)	CB5 (Blue)
-	-	-	-	-	3 ^{5/16} " / 99.4mm	8 ^{3/8} " / 213mm	4 ^{1/16} " (103.3mm)	Round: 9 ^{15/16} " (251.7mm) Square: 9 ^{11/16} x 9 ^{11/16} " (246.7 x 246.7mm)	Mineral Filled ABS Plastic (RoHS2 Compliant)	6lb (2.72kg)	CB6 (Purple)
-	✓	-	-	-	4 ^{1/2} " / 114mm	8 ^{1/4} " / 211mm	4 ^{3/8} " (118mm)	9 ^{13/16} " (250mm)	Mineral Filled ABS Plastic (RoHS2 Compliant)	4lb 4oz (1.92kg)	CB6 (Purple)
-	✓	-	-	-	4 ^{3/4} " / 121mm	9 ^{3/4} " / 247mm	4 ^{5/16} " (125mm)	11 ^{1/4} " (285mm)	Mineral Filled ABS Plastic (RoHS2 Compliant)	6lb (2.72kg)	CB8 (Green)
-	✓	-	✓	-	4 ^{1/2} " / 114mm	8 ^{1/4} " / 211mm	4 ^{3/8} " (118mm)	9 ^{13/16} " (250mm)	Mineral Filled ABS Plastic (RoHS2 Compliant)	4lb 8oz (2.04kg)	CB6 (Purple)
-	✓	-	✓	-	4 ^{3/4} " / 121mm	9 ^{3/4} " / 247mm	4 ^{5/16} " (125mm)	11 ^{1/4} " (285mm)	Mineral Filled ABS Plastic (RoHS2 Compliant)	6lb 2oz (2.8kg)	CB8 (Green)
IDC	✓	-	✓	-	5 ^{7/8} " / 149mm	8 ^{1/4} " / 211mm	6" (153mm)	9 ^{13/16} " (250mm)	Mineral Filled ABS Plastic (RoHS2 Compliant)	6lb 10oz (2.54kg)	CB6 (Purple)
IDC	✓	-	✓	-	6 ^{1/8} " / 156mm	9 ^{3/4} " / 247mm	6 ^{5/16} " (160mm)	11 ^{1/4} " (285mm)	Mineral Filled ABS Plastic (RoHS2 Compliant)	7lb 8oz (3.42kg)	CB8 (Green)
IDC	✓	-	✓	-	6 ^{1/8} " / 156mm	9 ^{3/4} " / 247mm	6 ^{5/16} " (160mm)	11 ^{1/4} " (285mm)	Mineral Filled ABS Plastic (RoHS2 Compliant)	8lb (3.64kg)	CB8 (Green)
FX	✓	-	-	✓	5 ^{7/8} " / 149mm	8 ^{1/4} " / 211mm	6" (153mm)	9 ^{13/16} " (250mm)	Mineral Filled ABS Plastic (RoHS2 Compliant)	4lb 10oz (2.08kg)	CB6 (Purple)
FX	✓	-	-	✓ Additional 12V Trigger Switching	6 ^{1/8} " / 156mm	9 ^{3/4} " / 247mm	6 ^{5/16} " (160mm)	11 ^{1/4} " (285mm)	Mineral Filled ABS Plastic (RoHS2 Compliant)	7lb (3.2kg)	CB8 (Green)
T2	-	-	-	-	4 ^{1/2} " / 114mm	8 ^{1/4} " / 211mm	4 ^{3/8} " (118mm)	9 ^{13/16} " (250mm)	Mineral Filled ABS Plastic (RoHS2 Compliant)	4lb 10oz (2.08kg)	CB6 (Purple)
T2	✓	-	-	-	4 ^{3/4} " / 121mm	9 ^{3/4} " / 247mm	4 ^{5/16} " (125mm)	11 ^{1/4} " (285mm)	Mineral Filled ABS Plastic (RoHS2 Compliant)	6lb 10oz (3kg)	CB8 (Green)
-	✓	-	-	-	3 ^{3/8} " / 85.5mm	13 ^{1/16} x 8 ^{3/8} " / 332 x 213mm	3 ^{1/2} " (89.5mm)	14 ^{9/16} x 9 ^{13/16} " (370 x 250mm)	Mineral Filled ABS Plastic (RoHS Compliant)	4lb 14oz (2.21kg)	WB6 (Purple)
-	✓	-	-	-	3 ^{11/16} " / 93mm	15 ^{1/4} x 9 ^{3/16} " / 387 x 234mm	3 ^{13/16} " (97.5mm)	17 ^{3/8} x 11 ^{5/16} " (441 x 288mm)	Mineral Filled ABS Plastic (RoHS Compliant)	6lb 12oz (3.08kg)	WB8 (Green)
-	✓	-	✓	-	3 ^{3/8} " / 85.5mm	13 ^{1/16} x 8 ^{3/8} " / 332 x 213mm	3 ^{1/2} " (89.5mm)	14 ^{9/16} x 9 ^{13/16} " (370 x 250mm)	Mineral Filled ABS Plastic (RoHS Compliant)	5lb (2.26kg)	WB6 (Purple)
-	✓	-	✓	-	3 ^{11/16} " / 93mm	15 ^{1/4} x 9 ^{3/16} " / 387 x 234mm	3 ^{13/16} " (97.5mm)	17 ^{3/8} x 11 ^{5/16} " (441 x 288mm)	Mineral Filled ABS Plastic (RoHS Compliant)	6lb 14oz (3.1kg)	WB8 (Green)
IDC	✓	-	✓	-	3 ^{11/16} " / 93mm	15 ^{1/4} x 9 ^{3/16} " / 387 x 234mm	3 ^{13/16} " (97.5mm)	17 ^{3/8} x 11 ^{5/16} " (441 x 288mm)	Mineral Filled ABS Plastic (RoHS Compliant)	7lb 14oz (3.6kg)	WB8 (Green)
IDC	✓	✓	✓	-	3 ^{13/16} " / 97.5mm	15 ^{1/4} x 9 ^{3/16} " / 387 x 234mm	4" (101.5mm)	17 ^{3/8} x 11 ^{5/16} " (441 x 288mm)	Mineral Filled ABS Plastic (RoHS Compliant)	9lb (4.1kg)	WB8 (Green)
LCR	-	-	-	-	4" / 100.2mm	5 ^{3/4} x 13 ^{7/8} " / 145 x 353mm	4 ^{1/8} " (105.4mm)	177.4 x 385.2mm (7 x 15 ^{3/16} "	Mineral Filled ABS Plastic (RoHS Compliant)	3.76kg (8.3lb)	WB5LCR (Yellow)
LCR	✓	-	-	-	4" / 100.2mm	5 ^{3/4} x 13 ^{7/8} " / 145 x 353mm	4 ^{1/8} " (105.4mm)	177.4 x 385.2mm (7 x 15 ^{3/16} "	Mineral Filled ABS Plastic (RoHS Compliant)	3.80kg (8.4lb)	WB5LCR (Yellow)
-	-	-	-	-	3 ^{5/8} " / 91.5mm	2 ^{1/2} " / 65mm	3 ^{3/4} " (96mm)	3 ^{1/8} " (80mm)	Steel Bezel / Aluminium Enclosure	0.42lb (0.19 Kg)	-
-	✓	-	-	-	5 ^{15/16} " / 151mm	8 ^{3/8} " / 212mm	6 ^{1/8} " (155mm)	9 ^{13/16} " (250mm)	Mineral Filled ABS Plastic (RoHS Compliant)	4lb 12oz (2.14kg)	CB6 (Purple)
-	✓	-	✓	-	5 ^{15/16} " / 151mm	9 ^{5/8} " / 244mm	6 ^{1/8} " (155mm)	11 ^{1/4} " (285mm)	Mineral Filled ABS Plastic (RoHS Compliant)	6lb 2oz (2kg)	CB8 (Green)
-	✓	-	✓	-	7 ^{1/8} " / 181mm	10 ^{13/16} " / 274mm	7 ^{3/8} " (187mm)	12 ^{3/16} " (309mm)	Mineral Filled ABS Plastic (RoHS Compliant)	8lb 4oz (3.74kg)	CB10 (Brown)
IDC	✓	✓	✓	-	7 ^{1/8} " / 181mm	10 ^{13/16} " / 274mm	7 ^{3/8} " (187mm)	12 ^{3/16} " (309mm)	Mineral Filled ABS Plastic (RoHS Compliant)	9lb 8oz (4.3kg)	CB10 (Brown)
-	✓	-	-	-	3 ^{3/4} " / 96mm	12 ^{3/16} x 8 ^{1/8} " / 326 x 207mm	4" (102mm)	14 ^{3/16} x 9 ^{1/2} " (360.5 x 242mm)	Mineral Filled ABS Plastic (RoHS Compliant)	5lb 14oz (2.65kg)	WB6 (Purple)
-	✓	-	✓	-	3 ^{3/4} " / 96mm	15 x 9" / 381 x 228mm	4" (102mm)	16 ^{5/16} x 10 ^{5/16} " (415 x 262.5mm)	Mineral Filled ABS Plastic (RoHS Compliant)	7lb 4oz (3.31kg)	WB8 (Green)
-	✓	-	✓	-	3 ^{7/8} " / 99mm	17 ^{1/4} x 10 ^{9/16} " / 438 x 269mm	4 ^{3/16} " (106mm)	18 ^{5/8} x 11 ^{15/16} " (472.5 x 303.5mm)	Mineral Filled ABS / Die-Cast Aluminium Baffle (RoHS Compliant)	10lb 14oz (4.95kg)	WB10 (Brown)
IDC	✓	✓	✓	-	3 ^{7/8} " / 99mm	17 ^{1/4} x 10 ^{9/16} " / 438 x 269mm	4 ^{3/16} " (106mm)	18 ^{5/8} x 11 ^{15/16} " (472.5 x 303.5mm)	Mineral Filled ABS / Die-Cast Aluminium Baffle (RoHS Compliant)	12lb 6oz (5.62kg)	WB10 (Brown)
LCR	✓	-	-	-	3 ^{13/16} " / 97mm	7 ^{3/16} x 11 ^{3/4} " / 183 x 299mm	4 ^{1/16} " (103mm)	8 ^{9/16} x 13 ^{1/16} " (217 x 333mm)	Mineral Filled ABS Plastic (RoHS Compliant)	5lb 8oz (2.5kg)	WB4LCR (Dark Brown)
LCR	✓	-	✓	-	3 ^{13/16} " / 97mm	7 ^{3/16} x 11 ^{3/4} " / 183 x 299mm	4 ^{1/16} " (103mm)	8 ^{9/16} x 13 ^{1/16} " (217 x 333mm)	Mineral Filled ABS Plastic (RoHS Compliant)	5lb 8oz (2.5kg)	WB4LCR (Dark Brown)
Full Size	✓	✓	✓	-	3 ^{3/4} " / 96mm	34 ^{21/32} x 9" / 880 x 230mm	4" (102mm)	3 ^{3/4} " (96mm)	Cast Polymer (RoHS2 Compliant)	26lb 6oz (11.98kg)	-
Full Size	✓	✓	✓	-	3 ^{3/4} " / 96mm	34 ^{21/32} x 9" / 880 x 230mm	4" (102mm)	3 ^{3/4} " (96mm)	Cast Polymer / Die- Cast Aluminium Baffle (RoHS2 Compliant)	28lb 6oz (12.98kg)	-
-	-	-	-	-	2 ^{15/16} " / 75mm	19 ^{11/16} x 13 ^{3/4} " / 501 x 351mm	3 ^{7/16} " (87.5mm)	21 ^{3/4} x 15 ^{13/16} " (552 x 402mm)	MDF	16lb 10oz (7.53kg)	-
-	-	-	-	-	2 ^{15/16} " / 75mm	29 ^{1/2} x 7 ^{7/8} " / 751 x 201mm	3 ^{7/16} " (87.5mm)	31 ^{5/8} x 9 ^{15/16} " (802.5 x 252.5mm)	MDF	16lb (7.26kg)	-
-	-	-	-	-	2 ^{5/16} " / 59.5mm	9 ^{7/8} x 9 ^{7/8} " / 251 x 251 mm	3" (77.5mm)	11 ^{7/8} x 11 ^{7/8} " (301.5 x 301.5mm)	MDF	6lb 10oz (3kg)	-
-	-	-	-	-	-	-	3 ^{7/16} " (87.5mm)	21 ^{1/4} x 15 ^{5/16} " (539 x 389mm)	MDF	16lb 6oz (7.44kg)	-
-	-	-	-	-	-	-	3 ^{7/16} " (87.5mm)	31 ^{1/8} x 9 ^{7/16} " (790 x 240mm)	MDF	15lb 9oz (7.06kg)	-
-	-	-	-	-	-	-	3" (77.5mm)	11 ^{3/8} x 11 ^{3/8} " (289 x 289mm)	MDF	6lb (2.76kg)	-

		Category	Application	Model Name	Page	Frequency Response	Impedance	Sensitivity (1W@1m)	Maximum SPL	Power Handling (RMS)	Recommended Amp Requirements	Driver & Technology	
RESIDENTIAL	INTERIOR DESIGN	Passive Soundbars	On-Wall	SB-2	27	90Hz - 30kHz	8Ω	86dB	104 (108.8 all channels driven)	40W	30 - 100W	3 x 4" C-CAM Drivers / 3 x 1" C-CAM Tweeters / ABR	
			On-Wall	SB-3	27	80Hz - 30kHz	8Ω	84dB/87dB/84dB	104 (108.8 all channels driven)	40W/80W/40W	30 - 100W	4 x 4" C-CAM Drivers / 3 x 1" C-CAM Tweeters / ABR	
		Invisible In-Wall	In-Wall	IV140	27	75Hz - 18KHz (CP sealed) 55Hz-18KHz (Open back)	8Ω	82dB (when installed as directed)	102.8dBA	50 Watts (full range - IEC268-5 rating) 100 Watts Music program (Using Minimum 80Hz High Pass filter)	20-50 Watts (full range) 20- 100 Watts (Using Minimum 80Hz High Pass filter)	1 x Low-Frequency exciter 2 x High-Frequency exciter	
FLAGSHIP	Platinum	In-Wall	PLIW II	31	52Hz - 100kHz	4Ω (3.7Ω min. @ 2.8KHz)	90dB	117dBA (pair)	200W	100 - 200W	2 x 6 ^{1/2} " RDT II Drivers / 4" RDT II Driver / MPD HF Transducer		
COMMERCIAL			In-Ceiling / In-Wall	PRO-65	34	75Hz - 20kHz	8Ω	86dB	101.5dBA	30W	10-30W	6 ^{1/2} " MMP II Driver / 1" fabric soft dome tweeter	
			In-Ceiling / In-Wall	PRO-80	34	60Hz - 20kHz	8Ω	87dB	103.8dBA	40W	10-40W	8" MMP II Driver / 1" fabric soft dome tweeter	
			In-Ceiling / In-Wall	PRO-80LV	34	65Hz - 25kHz	16Ω / 70V (4,8, 16,32,64 W) / 100V (8,16,32,64 W) power selection	87dB	103.8dBA	40W	10-40W	8" MMP II Driver / 1" fabric soft dome tweeter	
OUTDOOR	CLIMATE	Climate	On-Wall	CL50	36	75Hz - 30kHz	8Ω	87dB	106.8dBA	80W	10-80W	5 ^{1/2} " C-CAM Driver / 1" C-CAM Tweeter	
			On-Wall	CL60	36	63Hz - 30kHz	8Ω	88dB	108.8dBA	100W	15-100W	6 ^{1/2} " C-CAM Driver / 1" C-CAM Tweeter	
			On-Wall	CL60-T2	36	63Hz - 30kHz	2 x 8Ω	88dB	108.8dBA	2 x 50W	15-100W	6 ^{1/2} " C-CAM Driver / 2 x 1" C-CAM Tweeters	
			On-Wall	CL80	36	50Hz - 30kHz	8Ω	89.5dB	111.1dBA	120W	20-120W	8" C-CAM Driver / 1" C-CAM Tweeter	
	Climate Garden	In-Ground / On-Wall	CLG140	37	100Hz - 30kHz	70/100 Volt line level	88dB	104dBA	40W (crossover set to minimum 100Hz @ 12dB/Octave)	10-40W per speaker	4" MMP II Driver / 1" C-CAM Tweeter		
		In-Ground	CLG-W12	37, 43	30Hz - 100Hz	4Ω or 70/100V line level (cable select)	87dB	110dBA	250W	100-250W	12" C-CAM Driver		
	ALL WEATHER	AWC		In-Ceiling / In-Wall	AWC265	39	60Hz - 30kHz	8Ω 4.4Ω @190Hz	88dB	105.8dBA	60W	20 - 60W	6 ^{1/2} " C-CAM Driver / 1" C-CAM Tweeter
				In-Ceiling / In-Wall	AWC265-T2	39	50Hz - 30kHz	8Ω 4.5Ω @185Hz	89dB	109dBA	100W	20 - 100W	6 ^{1/2} " C-CAM Driver / 2 x 1" C-CAM Tweeters
In-Ceiling / In-Wall				AWC280	39	60Hz - 30kHz	8 + 8Ω 4.5Ω @185Hz	88dB (both channels driven)	105.8dBA	60W	20 - 60W	8" C-CAM Driver / 1" C-CAM Tweeter	
In-Ceiling / In-Wall				AWC280-T2	39	50Hz - 30kHz	8 + 8Ω 4.5Ω @185Hz	89dB (both channels driven)	109dBA	100W	20 - 100W	8" C-CAM Driver / 2 x 1" C-CAM Tweeters	
SUBWOOFER	Subwoofer	In-Wall	IWS-10	42	28Hz - 120Hz	8Ω	86dB	Single unit 109.8dB; Pair 115.8dB	150 W	-	C-CAM Driver		
	Box	In-Wall	IWB-10	42	-	-	-	-	-	-	-		
	Amplifier	-	IWA-250	42	25Hz-120Hz	-	-	-	-	-	-		
	Custom Subwoofer	On-Floor	CW8	43		> 20KΩ		105.8dBA				8" C-CAM Driver / ABR	
		On-Floor	CW10	43		> 20KΩ		105.8dBA				10" C-CAM Driver / ABR	
ACCESSORIES	Square Grilles				46								
	SoundFrame Frameless Grilles				46								
	CLG-Spike R				47								
	CLG-Mount				47								
	Pre-Construction Brackets				47								
	Back-boxes				47								
	Coming Soon - Firehoods				47								



RESIDENTIAL



RANGES: - SLIM
- CORE
- CONTROLLED PERFORMANCE
- INTERIOR DESIGN

SLIM / CORE / CONTROLLED PERFORMANCE: MOUNTING DEPTH OVERVIEW

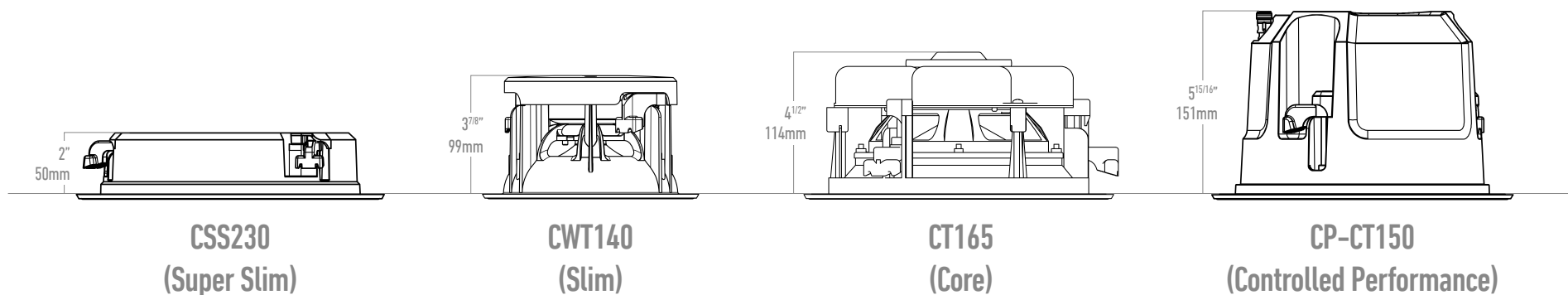

ILLUSTRATION COMPARING MOUNTING DEPTH, FEATURING SLIMMEST MODELS FROM EACH IN-CEILING RANGE (SCALE - 1:5)

SLIM RANGE

Maximum depth of 4"

Featuring versatile installation options for both in-ceiling and in-wall applications, the Slim Range offers exceptional audio performance in a near invisible easy-to-install format. Behind super-discreet trimless grilles, acoustic systems of Monitor Audio's trademark bass drivers and pivoting C-CAM gold dome tweeters have been optimised by FEA analysis to deliver high efficiency combined with a broad frequency response, for a wide range of demanding residential and commercial installations.

Having a physical depth of less than 10cm (4"), the Super Slim and Slim models are perfect for easy installation in many more locations, being ideal for standard stud walls and where depth is restricted. What's more, by integrating the bass driver basket with the frame, our engineers have reduced overall speaker size by 25% over conventional speakers without any performance penalty. All Slim, Core and Controlled Performance range models incorporate Monitor Audio's innovative, robust and reliable Tri-Grip fixing design: a secure 'dog' style fixing with three contact points.

Wherever Monitor Audio's speakers are installed, their innate versatility, 'stealthy' appearance and high performance will deliver great sound and easy, discreet, décor-friendly installation.

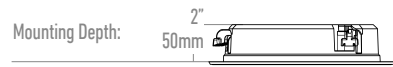

IMAGE OF CW240 SHOWING SIDE DETAIL AND CIRCULAR GRILLE (NOT TO SCALE)

SLIM RANGE (IN-CEILING)

SUPER SLIM

CSS230



Cutout Diameter: 8^{1/4}" / 211mm

- 2" mounting depth
- C-CAM gold dome tweeter
- 3 x 3" C-CAM drivers, enabling slim profile with the performance of a single 6" driver
- Sealed rear enclosure for acoustic isolation
- Rubber plug can be removed for open back design and increased low frequency performance
- Magnetic grille attachment
- Tri-Grip dog leg fixings.

SLIM

CWT140

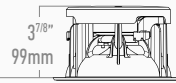

5^{7/8}" / 149mm

- Less than 4" mounting depth
- 1" C-CAM pivoting gold dome tweeter
- 4" MMP II driver
- Magnetic grille attachment
- Tri-Grip dog leg fixings.

CWT240

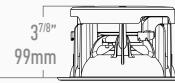

5^{7/8}" / 149mm

- Less than 4" mounting depth
- 1" C-CAM pivoting gold dome tweeter
- 4" C-CAM driver
- Magnetic grille attachment
- Tri-Grip dog leg fixings.

CWT160

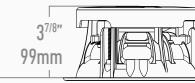

6^{11/16}" / 170mm

- Less than 4" mounting depth
- 1" C-CAM pivoting gold dome tweeter
- 6" MMP II driver
- Magnetic grille attachment
- Tri-Grip dog leg fixings.

CWT180

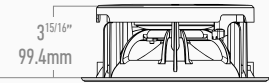

8^{3/8}" / 213mm

- Less than 4" mounting depth
- 1" C-CAM pivoting gold dome tweeter
- 8" MMP II driver
- Magnetic grille attachment
- Tri-Grip dog leg fixings.

CORE RANGE (IN-CEILING)

Depth between 4^{1/2}" - 6^{1/2}"

Please refer to Page 39 for AWC (All weather in-ceiling) speakers >

CORE MODELS

CT165

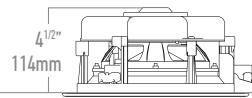

8^{1/4}" / 211mm

- Less than 5" mounting depth
- 1" C-CAM pivoting gold dome tweeter
- 6^{1/2}" MMP II driver
- HF level switch
- Magnetic grille attachment
- Tri-Grip dog leg fixings.

CT180

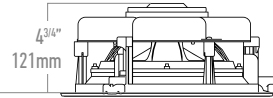

9^{3/4}" / 247mm

- Less than 5" mounting depth
- 1" C-CAM pivoting gold dome tweeter
- 8" MMP II driver
- HF level switch
- Magnetic grille attachment
- Tri-Grip dog leg fixings.

CT265

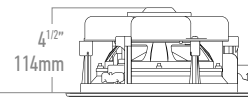

8^{1/4}" / 211mm

- Less than 5" mounting depth
- 1" C-CAM pivoting gold dome tweeter
- 6^{1/2}" C-CAM driver
- HF level switch
- Boundary compensation switch
- Magnetic grille attachment
- Tri-Grip dog leg fixings.

CT280

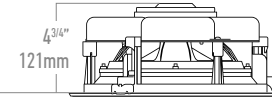

9^{3/4}" / 247mm

- Less than 5" mounting depth
- 1" C-CAM pivoting gold dome tweeter
- 8" C-CAM driver
- HF level switch
- Boundary compensation switch
- Magnetic grille attachment
- Tri-Grip dog leg fixings.

CT265-IDC

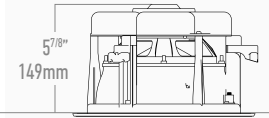

8^{1/4}" / 211mm

- Less than 6" mounting depth
- Pivoting IDC module (1" C-CAM gold dome tweeter, 4" C-CAM RST inverted mid range driver)
- 6^{1/2}" C-CAM driver
- HF level switch
- Boundary compensation switch
- Magnetic grille attachment
- Tri-Grip dog leg fixings.

IDC | 3-WAY

Mounting Depth:

Cutout Diameter:

Monitor Audio's in-wall and in-ceiling speakers are engineered for high performance, reliability and ease-of-use. They've been developed using the advanced driver technologies of our award-winning hi-fi speaker ranges to deliver world-famous sound quality without compromising room design. Available across four performance levels, Monitor Audio's architectural speakers bring innovation to every application - wherever you decide to experience dynamic music and film sound, there's an in-wall or in-ceiling speaker that's perfect for the role, expertly optimised for rhythmic wideband audio, seamless room integration and easy, secure installation.

FX | SURROUND

T2 | STEREO

CT280-IDC

CT380-IDC

CT265-FX

CT380-FX

CT165-T2

CT180-T2

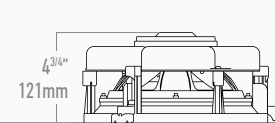
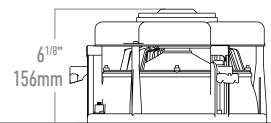
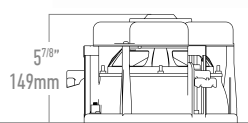
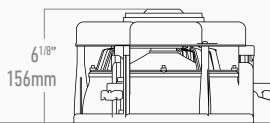
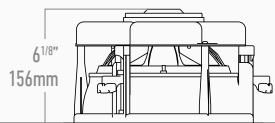

9 3/4" / 247mm

9 3/4" / 247mm

8 1/4" / 211mm

9 3/4" / 247mm

8 1/4" / 211mm

9 3/4" / 247mm

- Less than 7" mounting depth
- Pivoting IDC module (1" C-CAM gold dome tweeter, 4" C-CAM RST inverted mid range driver)
- 8" C-CAM driver
- HF level switch
- Boundary compensation switch
- Magnetic grille attachment
- Tri-Grip dog leg fixings.

- Less than 7" mounting depth
- Pivoting IDC module (1" C-CAM gold dome tweeter, 4" C-CAM RST inverted mid range driver)
- 8" C-CAM RST driver
- HF level switch
- Boundary compensation switch
- Magnetic grille attachment
- Tri-Grip dog leg fixings.

- Less than 6" mounting depth
- 2 x 1" C-CAM gold dome tweeters
- 6 1/2" C-CAM driver
- HF level switch
- Bi pole / Di pole switch
- Magnetic grille attachment
- Tri-Grip dog leg fixings.

- Less than 8" mounting depth
- 2 x 1" C-CAM gold dome tweeters
- 8" C-CAM RST driver
- HF level switch
- Bi pole / Di pole switch
- Additional 12V trigger switching
- Magnetic grille attachment
- Tri-Grip dog leg fixings.

- Less than 5" mounting depth
- 2 x 1" C-CAM pivoting gold dome tweeters
- 6 1/2" MMP II driver
- Magnetic grille attachment
- Tri-Grip dog leg fixings.

- Less than 5" mounting depth
- 2 x 1" C-CAM pivoting gold dome tweeters
- 8" MMP II driver
- HF level switch
- Magnetic grille attachment
- Tri-Grip dog leg fixings.

CORE RANGE (IN-WALL)

Maximum depth of 4"

CORE MODELS

WT165

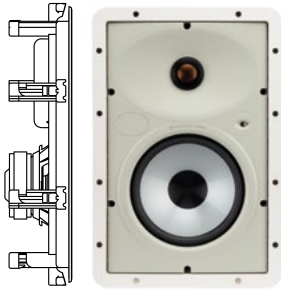

Mounting Depth: $3^{3/8}$ " / 85.5mm
Cutout Dimensions: $13^{1/16}$ " x $8^{3/8}$ " / 332 x 213mm

- Less than 4" mounting depth
- 1" C-CAM pivoting gold dome tweeter
- $6^{1/2}$ " MMP II driver
- HF level switch
- Magnetic grille attachment
- Tri-Grip dog leg fixings.

WT180

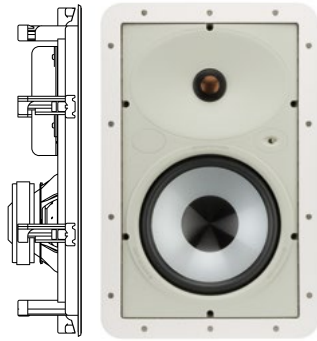

Mounting Depth: $3^{11/16}$ " / 93mm
Cutout Dimensions: $15^{1/4}$ " x $9^{3/16}$ " / 387 x 234mm

- Less than 4" mounting depth
- 1" C-CAM pivoting gold dome tweeter
- 8" MMP II driver
- HF level switch
- Magnetic grille attachment
- Tri-Grip dog leg fixings.

WT265

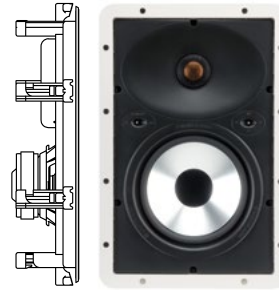

Mounting Depth: $3^{3/8}$ " / 85.5mm
Cutout Dimensions: $13^{1/16}$ " x $8^{3/8}$ " / 332 x 213mm

- Less than 4" mounting depth
- 1" C-CAM pivoting gold dome tweeter
- $6^{1/2}$ " C-CAM driver
- HF level switch
- Magnetic grille attachment
- Tri-Grip dog leg fixings.

WT280



Mounting Depth: $3^{11/16}$ " / 93mm
Cutout Dimensions: $15^{1/4}$ " x $9^{3/16}$ " / 387 x 234mm

- Less than 4" mounting depth
- 1" C-CAM pivoting gold dome tweeter
- 8" C-CAM driver
- HF level switch
- Boundary compensation switch
- Magnetic grille attachment
- Tri-Grip dog leg fixings.

IDC | 3-WAY

WT280-IDC

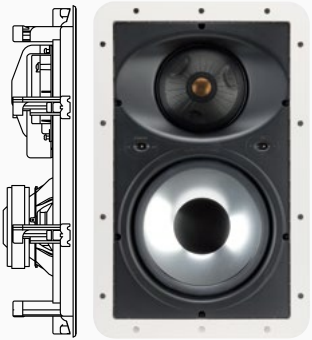

3^{11/16}" / 93mm
15^{1/4}" x 9^{3/16}" / 387 x 234mm

- Less than 4" mounting depth
- Pivoting IDC module (1" C-CAM gold dome tweeter, 4" C-CAM RST inverted mid range driver)
- 8" C-CAM driver
- HF level switch
- Boundary compensation switch
- Magnetic grille attachment
- Tri-Grip dog leg fixings.

WT380-IDC

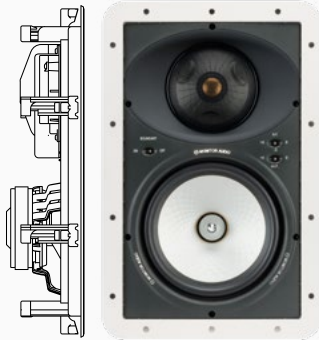

3^{13/16}" / 97.5mm
15^{1/4}" x 9^{3/16}" / 387 x 234mm

- Less than 4" mounting depth
- Pivoting IDC module (1" C-CAM gold dome tweeter, 4" C-CAM RST inverted mid range driver)
- 8" C-CAM RST driver
- HF & MF level switches
- Boundary compensation switch
- Magnetic grille attachment
- Tri-Grip dog leg fixings.

LCR

WT150-LCR



4" / 100.2mm
5^{3/4}" x 13^{7/8}" / 145 x 353mm

- 4" mounting depth
- 1" C-CAM pivoting gold dome tweeter
- 2 x 5" MMP II drivers
- Magnetic grille attachment
- Tri-Grip dog leg fixings
- Fit within standard 400mm / 16" centre studs.

WT250-LCR



4" / 100.2mm
5^{3/4}" x 13^{7/8}" / 145 x 353mm

- 4" mounting depth
- 1" C-CAM pivoting gold dome tweeter
- 2 x 5" C-CAM drivers
- HF level switch
- Magnetic grille attachment
- Tri-Grip dog leg fixings
- Fit within standard 400mm / 16" centre studs.

CONTROLLED PERFORMANCE RANGE

Given the choice, most home owners would favour great sound from 'invisible' speakers over traditional box designs. But as every custom installer will confirm, fitting drivers flush with room surfaces is only part of the solution. They know that sound quality relies as much on the acoustics of the void behind the walls and ceilings, as the size and shape of the room in front of them. This is why the challenge of achieving the wide, detailed, dynamic sound of box speakers - in a room without boxes - is made so much easier with Monitor Audio's 'Controlled Performance' range. Unlike open-backed architectural speakers, the CP range is fitted with fully-sealed back-boxes that reduce the sound from the back of the cabinet by around 30dB. They are, in fact, brilliant miniature cabinet speakers optimised for in-wall/in-ceiling locations. From our CP models you'll enjoy the performance of a genuine Monitor Audio cabinet speaker, and the super-discreet qualities of near-invisible installation combined.



IMAGES OF CP-CT380iDC SHOWING SIDE DETAIL AND BACK-BOX (NOT TO SCALE)

CONTROLLED PERFORMANCE RANGE (IN-CEILING)

MICRO SPEAKER

CPC120



Mounting Depth:



Cutout Diameter:

2 1/2" / 65mm

- Less than 4" mounting depth
- 2" Full range micro-driver
- Sealed back box
- Quick and easy discreet flush-fit to walls or ceilings
- Conventional fitment clips offer quick and simple installation
- Available in four finishes (brushed steel, chrome, brass and white).

CORE MODELS

CP-CT150

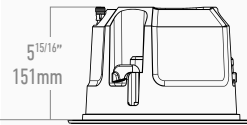

8 3/8" / 212mm

- Less than 6" mounting depth
- 1" C-CAM pivoting gold dome tweeter
- 5" MMP II driver
- HF level switch
- Sealed back box
- Magnetic grille attachment
- Tri-Grip dog leg fixings.

CP-CT260

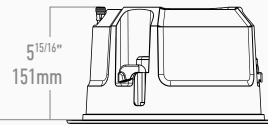

9 5/8" / 244mm

- Less than 6" mounting depth
- 1" C-CAM pivoting gold dome tweeter
- 6" C-CAM driver
- HF level switch
- Boundary compensation switch
- Sealed back box
- Magnetic grille attachment
- Tri-Grip dog leg fixings.

CP-CT380

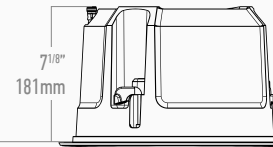

10 13/16" / 274mm

- Less than 8" mounting depth
- 1" C-CAM pivoting gold dome tweeter
- 8" C-CAM RST driver
- HF level switch
- Boundary compensation switch
- Sealed back box
- Magnetic grille attachment
- Tri-Grip dog leg fixings.

IDC | 3-WAY

CP-CT380IDC

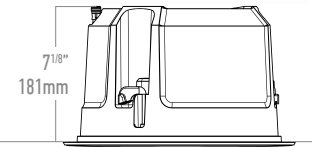

10 13/16" / 274mm

- Less than 8" mounting depth
- Pivoting IDC module (1" C-CAM gold dome tweeter, 4" C-CAM RST inverted mid range driver)
- 8" C-CAM RST driver
- HF & MF level switches
- Boundary compensation switch
- Sealed back box
- Magnetic grille attachment
- Tri-Grip dog leg fixings.

CONTROLLED PERFORMANCE RANGE (IN-WALL)

CORE MODELS

CP-WT150

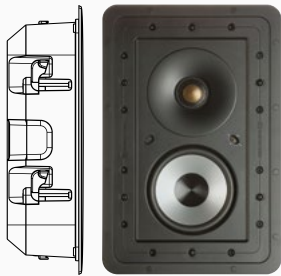

Mounting Depth: 3^{3/4}" / 96mm
Cutout Dimensions: 12^{13/16}" x 8^{1/8}" / 326 x 207mm

- Less than 4" mounting depth
- 1" C-CAM pivoting gold dome tweeter
- 5" MMP II driver
- HF level switch
- Sealed back box
- Magnetic grille attachment
- Tri-Grip dog leg fixings.

CP-WT260

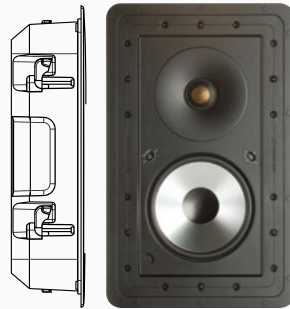

Mounting Depth: 3^{3/4}" / 96mm
Cutout Dimensions: 15 x 9" / 381 x 228mm

- Less than 4" mounting depth
- 1" C-CAM pivoting gold dome tweeter
- 6" C-CAM driver
- HF level switch
- Boundary compensation switch
- Sealed back box
- Magnetic grille attachment
- Tri-Grip dog leg fixings.

CP-WT380

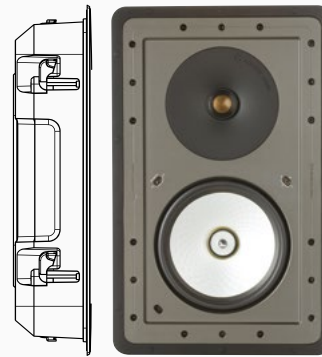

Mounting Depth: 3^{7/8}" / 99mm
Cutout Dimensions: 17^{1/4}" x 10^{9/16}" / 438 x 269mm

- Less than 4" mounting depth
- 1" C-CAM pivoting gold dome tweeter
- 8" C-CAM RST driver
- HF level switch
- Boundary compensation switch
- Sealed back box
- Magnetic grille attachment
- Tri-Grip dog leg fixings.

IDC | 3-WAY

CP-WT380IDC

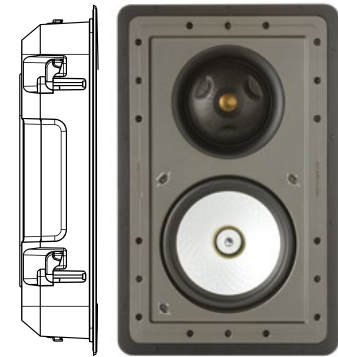

Mounting Depth: 3^{7/8}" / 99mm
Cutout Dimensions: 17^{1/4}" x 10^{9/16}" / 438 x 269mm

- Less than 4" mounting depth
- Pivoting IDC module (1" C-CAM gold dome tweeter, 4" C-CAM RST inverted mid range driver)
- 8" C-CAM RST driver
- HF & MF level switches
- Boundary compensation switch
- Sealed back box
- Magnetic grille attachment
- Tri-Grip dog leg fixings.

LCR

CP-WT140LCR



Mounting Depth:
3¹³/₁₆" / 97mm

Cutout Dimensions:
7³/₁₆" x 11³/₁₆" / 183 x 299mm

- Less than 4" mounting depth
- 1" C-CAM pivoting gold dome tweeter
- 2 x 4" MMP II drivers
- HF level switch
- Sealed back box
- Magnetic grille attachment
- Tri-Grip dog leg fixings
- Fit within standard 400mm / 16" centre studs.

CP-WT240LCR



Mounting Depth:
3¹³/₁₆" / 97mm

Cutout Dimensions:
7³/₁₆" x 11³/₁₆" / 183 x 299mm

- Less than 4" mounting depth
- 1" C-CAM pivoting gold dome tweeter
- 2 x 4" C-CAM drivers
- HF level switch
- Boundary compensation switch
- Sealed back box
- Magnetic grille attachment
- Tri-Grip dog leg fixings
- Fit within standard 400mm / 16" centre studs.

PERFORMANCE FULL SIZE

The 'Controlled Performance' CP-IW260X and CP-IW460X in-wall designs have overcome the challenges of scale to deliver the natural, full-range audio energy you'd expect from a free-standing high-end box. In a leap of engineering ingenuity, we've distilled the know-how driving our flagship hi-fi speakers into a super-compact in-wall format, so that dedicated music lovers and home theatre fans can enjoy the rich, detailed, high-impact dynamics they crave, from a speaker that physically disappears in the room. Both Full Size models can be installed in horizontal or vertical orientations, with the HF tweeter module of the CP-IW460X designed to rotate 90° to suit the chosen speaker placement.

CP-IW260X

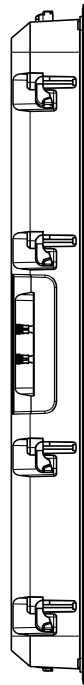

Mounting Depth:
3³/₄" / 96mm

Cutout Dimensions:
34²/₁₃₂" x 9" / 880 x 230mm

- Less than 4" mounting depth
- 1" C-CAM gold dome tweeter
- 2 x 6¹/₂" C-CAM bass drivers
- 2 x 4" C-CAM mid range drivers
- HF & MF level switches
- Boundary compensation switch
- Portrait or landscape orientation
- Sealed back box
- Magnetic grille attachment
- Tri-Grip dog leg fixings.

CP-IW460X



Mounting Depth:
3³/₄" / 96mm

Cutout Dimensions:
34²/₁₃₂" x 9" / 880 x 230mm

- Less than 4" mounting depth
- 1" C-CAM ribbon transducer
- 2 x 6¹/₂" C-CAM RST bass drivers
- 2 x 4" C-CAM RST mid range drivers
- Die-cast alloy bass driver chassis provides rigidity; results in punch bass and clean mid-range performance due to reduced transfer of vibrations
- HF & MF level switches
- Boundary compensation switch
- Innovative HF tweeter rotating system to facilitate portrait or landscape orientation
- Sealed back box
- Magnetic grille attachment
- Tri-Grip dog leg fixings.

Pre Construction Bracket WB12 now available

INTERIOR DESIGN RANGE

SOUNDFRAME

- 'In-Wall' or 'On-Wall' versions available
- Ultra slim profile
- Customized grille options
- Pivoting tweeters
- Easy Install, wire-free look
- Available finishes: Black gloss / white gloss

Frameless grille options available - entire front profile of the speaker can display colour or artwork of your choosing, without the surrounding black/white frame (available for all SoundFrame models). See Accessories (Page 46).



SF1

In-Wall Mounting Depth:
In-Wall Cutout Dimensions:
On-Wall Overall Dimensions (H x W x D):

2¹⁵/₁₆" / 75mm
 19¹¹/₁₆" x 13³/₁₆" / 501 x 351mm
 21¹/₄" x 15⁵/₁₆" x 3⁷/₁₆" / 539 x 389 x 87.5mm

- Less than 3" mounting depth (InWall version)
- Pivoting IDC module (1" C-CAM gold dome tweeter, 4" C-CAM RST inverted mid range driver)
- 6¹/₂" C-CAM RST driver
- Library or bespoke grille artwork available
- Sealed back box
- HF Control.

SF2

In-Wall Mounting Depth:
In-Wall Cutout Dimensions:
On-Wall Overall Dimensions (H x W x D):

2¹⁵/₁₆" / 75mm
 29¹/₂" x 7⁷/₈" / 751 x 201mm
 31¹/₈" x 9⁷/₁₆" x 3⁷/₁₆" / 790 x 240 x 87.5mm

- Less than 3" mounting depth (InWall version)
- Pivoting IDC module (1" C-CAM gold dome tweeter, 4" C-CAM RST inverted mid range driver)
- 6¹/₂" C-CAM RST driver
- Library or bespoke grille artwork available
- Sealed back box
- HF Control.

SF3

In-Wall Mounting Depth:
In-Wall Cutout Dimensions:
On-Wall Overall Dimensions (H x W x D):

2⁵/₁₆" / 59.5mm
 9⁷/₈" x 9⁷/₈" / 251 x 251mm
 11³/₈" x 11³/₈" x 3" / 289 x 289 x 77.5mm

- Less than 3" mounting depth (InWall version)
- 1" C-CAM pivoting gold dome tweeter
- 4" C-CAM driver
- Library or bespoke grille artwork available
- Sealed back box.

PASSIVE SOUNDBARS

SB-2



Overall Dimensions (H x W x D):
5^{11/16} x 43^{11/16} x 3^{1/2}"
145 x 1110 x 89mm

- 3 x 1" C-CAM gold dome tweeters
- 3 x 4" C-CAM drivers
- 3 x ABRs (auxiliary bass radiator)
- Freestanding or wall mountable (wall bracket sold separately)
- Suitable for 50 - 60" TVs.

SB-3



Overall Dimensions (H x W x D):
5^{11/16} x 51^{9/16} x 3^{1/2}"
145 x 1310 x 89mm

- 3 x 1" C-CAM gold dome tweeters
- 4 x 4" C-CAM drivers
- 4 x ABRs (auxiliary bass radiator)
- Freestanding or wall mountable (wall bracket sold separately)
- Suitable for ≥60" TVs.

INVISIBLE IN-WALL

IV140



Closed back



Opened back

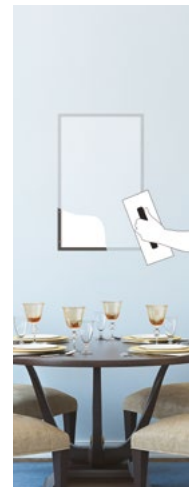

Overall Dimensions (H x W x D):
25^{5/16} x 15^{13/16} x 3^{13/16}"
642 x 401 x 95.5mm

- 2-way system with integrated crossover
- Pre-construction speaker designed to be plastered in to create 'invisible' appearance
- Low-frequency exciter, featuring high power ceramic magnetics and 40mm voice coil
- Dual High-frequency exciters, incorporating high power Neo magnets and 30mm voice coils
- Rigid MDF back box construction
- Integrated 'hybrid' controlled performance back box system – Fully sealed or open-back
- High Quality crossover – including metallised film capacitors and low loss steel core inductors
- Protected against overload by PTC's (automatically re-setting breakers)
- Ideal for home cinema, distributed audio, hospitality, retail and commercial background music applications where aesthetics and discretion are key factors.



FLAGSHIP



PLATINUM II RANGE (Unique Technology)

For over 40 years, our work as engineers and audio enthusiasts has been dedicated to the unveiling of the Platinum II flagship range. With our most advanced driver, crossover and acoustics systems set within luxurious cabinets, we've tuned the virtues that have won Monitor Audio worldwide acclaim to a new intensity, allowing rarefied audio transparency to be revealed and enjoyed. Platinum II is our magnum opus, as inspirational and satisfying to us as we hope it will be to you.

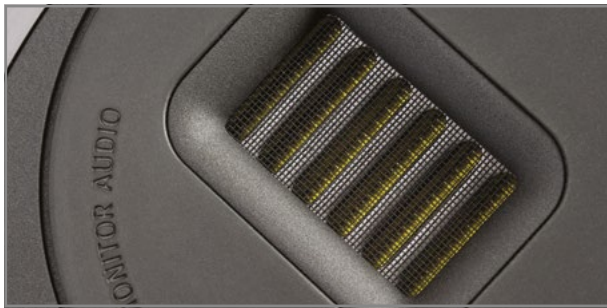

MPD (MICRO PLEATED DIAPHRAGM) HIGH FREQUENCY TRANSDUCER:

Developed over many months of intensive testing and listening, the MPD High Frequency Transducer is a landmark achievement by the engineering team for Platinum II. It represents an imaginative re-working of an existing technology, transforming a successful idea into an audiophile super-driver, having greater accuracy and efficiency than ever before. Using a new, proprietary low-mass pleated diaphragm with a surface area eight times larger than that of a traditional dome tweeter, the MPD transducer works like a super-fast accordion by rapidly squeezing the pleats to produce a smooth, wide, naturally fast response up to 100kHz. As a result it sounds more lifelike, releasing the high harmonic spectrum of every note without the distortion that blurs definition.



RDT II (RIGID DIAPHRAGM TECHNOLOGY 2ND GENERATION):

A composite 'sandwich' structure made from ultra-thin low mass skins, bonded to a honeycomb Nomex® core material. It is very light and very strong, meaning that it can respond with great speed without bending - just like a perfect piston. RDT II uses C-CAM for the front skin, while the rear skin is made from a woven carbon fibre material. We discovered that the new structure reduces distortion by over 8dB above 300Hz, which makes RDT II the lowest distortion cone technology in Monitor Audio's history.

PLATINUM II RANGE

PLATINUM IN-WALL II

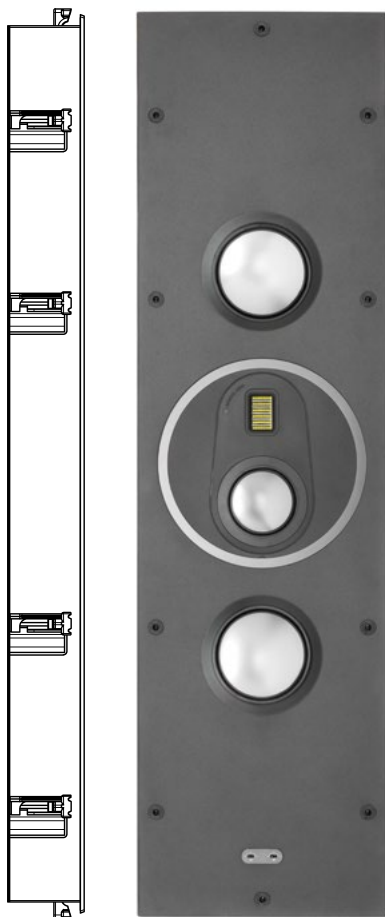

Mounting Depth:
3¹³/₁₆" / 97.5mm

Cutout Dimensions:
46⁷/₁₆" x 11⁷/₈"
1179 x 302mm

- Flagship in wall luxury speaker
- Less than 4" mounting depth
- MPD high frequency transducer
- 2 x 6¹/₂" RDT II bass drivers
- 4" RDT II mid range driver
- HF & MF level switches
- Mid range/tweeter module rotates for horizontal or vertical placement.
- Sealed back box
- Magnetic grille attachment
- Tri-Grip dog leg fixings.







COMMERCIAL

COMMERCIAL RANGE

COMMERCIAL SPEAKER WITH POWER TAPS

PRO-IC

PRO-65



PRO-80



PRO-80LV



Mounting Depth:

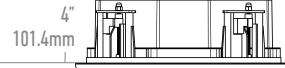
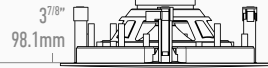

Cutout Diameter:

7 7/8" / 200.5mm

9 5/8" / 245mm

10 3/8" / 264mm

- Less than 4" mounting depth
- 1" pivoting tweeter
- 6 1/2" MMP II driver
- Magnetic grille attachment
- Dog leg fixings
- Dust protection covers
- Only available in packs of 5.

- Less than 4" mounting depth
- 1" pivoting tweeter
- 8" MMP II driver
- Magnetic grille attachment
- Dog leg fixings
- Dust protection covers
- Only available in packs of 5.

- Less than 4" mounting depth
- 1" C-CAM gold dome tweeter
- 8" MMP II driver
- Dog leg fixings
- Dust protection covers
- Ideal for projects with a large quantity of loudspeakers over large distances
- Transformer with 70/100V input for installation on one amplifier channel
- 16Ω, power level taps at 4,8,16,32W
- Fireproof steel rear can
- 'Easy-fit' connection block – Provides link out for 'daisy chain' connection
- Anchor point fixings
- Only available in packs of 4.



OUTDOOR

CLIMATE RANGE

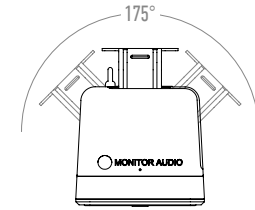

CL50 Top View: Bracket allows for 175° rotation on horizontal axis.

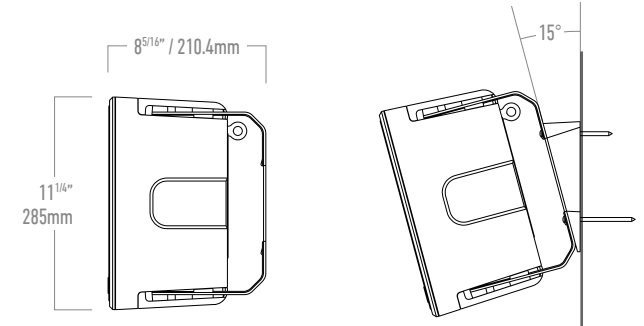

CL50 Side View: Speaker position can be fine tuned by using optional 15° angle block.

CL50

Overall Dimensions (H x W x D):

11 1/4" x 6 13/16" x 6 1/4"
285 x 172.5 x 158.5mm

- Wall mounted
- 1" C-CAM gold dome tweeter
- 5 1/2" C-CAM driver
- Rear mounted ABR (auxiliary bass radiator)
- Aluminium grille prevents rust
- Solid polypropylene sealed enclosure
- Certified to IP55 rating - resistant to UV, corrosion, water
- Installation flexibility: 175° rotational bracket and anchor point fixings.
- Operating temperature range: -25°C to 65°C / -13° to 149°F.

CL60

12 13/16" x 7 5/16" x 7"
325 x 185 x 178.5mm

- Wall mounted
- 1" C-CAM gold dome tweeter
- 6" C-CAM driver
- Rear mounted ABR (auxiliary bass radiator)
- Aluminium grille prevents rust
- Solid polypropylene sealed enclosure
- Certified to IP55 rating - resistant to UV, corrosion, water
- Installation flexibility: 175° rotational bracket and anchor point fixings.
- Operating temperature range: -25°C to 65°C / -13° to 149°F.

CL60-T2

12 13/16" x 7 5/16" x 7"
325 x 185 x 178.5mm

- Wall mounted
- 2 x 1" C-CAM gold dome tweeters
- 6" C-CAM driver
- Rear mounted ABR (auxiliary bass radiator)
- Aluminium grille prevents rust
- Solid polypropylene sealed enclosure
- Certified to IP55 rating - resistant to UV, corrosion, water
- Installation flexibility: 175° rotational bracket and anchor point fixings
- T2: Stereo with double tweeter.
- Operating temperature range: -25°C to 65°C / -13° to 149°F.

CL80

15 15/16" x 9 1/16" x 8 11/16"
405 x 230 x 221mm

- Wall mounted
- 1" C-CAM gold dome tweeter
- 8" C-CAM driver
- Rear mounted ABR (auxiliary bass radiator)
- Aluminium grille prevents rust
- Solid polypropylene sealed enclosure
- Certified to IP55 rating - resistant to UV, corrosion, water
- Installation flexibility: 175° rotational bracket and anchor point fixings.
- Operating temperature range: -25°C to 65°C / -13° to 149°F.



LIFESTYLE IMAGE NOT TO SCALE

CLIMATE GARDEN RANGE

CLG140

Overall Dimensions
(Without Spike or Bracket):
7¹/₂ x 5¹/₈ x 6⁷/₈ / 190.9 x 130 x 175mm

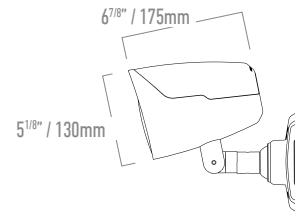
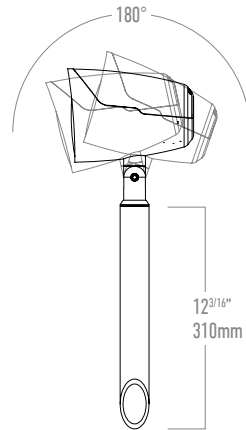

- 4" C-CAM driver
- 1" C-CAM gold dome tweeter
- 70/100V line operation with cable connection provided
- Optional wall bracket or ground spike (sold separately)
- Certified to IP55 rating
- Rigid, high impact cast polymer cabinet for long life and durability
- Dark Brown finish to blend into garden environment
- Custom DSP filter settings for Crown CDi series
- Designed to operate under extreme climatic conditions between -20 to 70°C / -4 to 158°F.

Position close to the garden surface with the CLG-SPIKE R, which neatly encapsulates and channels the connecting cable into the ground for a discreetly installed result.

The ball joint design in the CLG-MOUNT allows for greater freedom of positioning the CLG140, to adapt perfectly to the intended environment.

CLG-W12

Overall Dimensions:
31⁷/₈ x 14¹⁵/₁₆ x 19⁷/₈ / 810 x 380 x 505.5mm

- Long Throw 12" C-CAM driver
- Passive design with 70/100V and 4Ω tap for flexible system design
- High impact moulded cabinet - robust and waterproof
- Certified to IP67 rating
- Dark Brown finish to blend into garden environment
- Custom DSP filter settings for Crown CDi series
- Designed to operate under extreme climatic conditions between -20 to 70°C / -4 to 158°F.

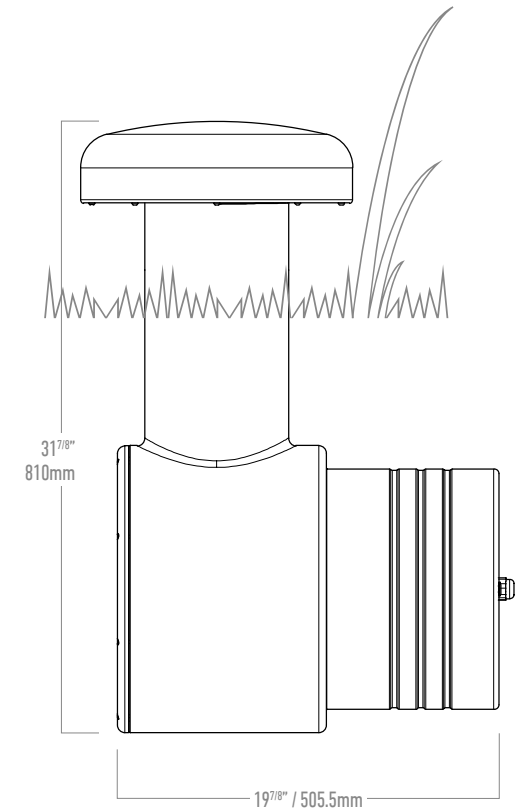

ALL WEATHER RANGE

With more of us enjoying the freedom of recreation in the great outdoors, make the party with a burst of full-range fidelity from the new super-discreet weatherproof AWC series speaker. Created for sound in tougher environmental conditions, where a higher IP rating is required.

Developed using all-C-CAM driver systems derived from our critically acclaimed hi-fi speakers, the four new All Weather in-Ceiling models are meticulously engineered with advanced levels of water, dust, corrosion, UV and temperature protection to provide outdoor audio installations with great sound and long-term reliability in the most challenging all-weather environments. All AWC models feature round grilles, with optional square grilles available separately.



ALL WEATHER RANGE (IN-CEILING)

AWC265



AWC265-T2



AWC280



AWC280-T2



Mounting Depth:

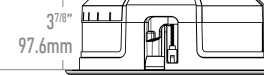
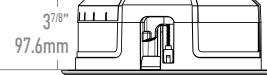
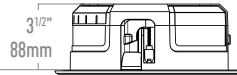
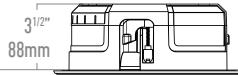

Cutout Diameter:

8 1/4" / 211mm

8 1/4" / 211mm

9 3/4" / 247mm

9 3/4" / 247mm

- Less than 4" mounting depth
- 1" C-CAM gold dome tweeter
- 6 1/2" C-CAM driver.

- Less than 4" mounting depth
- 2 x 1" C-CAM gold dome tweeters
- 6 1/2" C-CAM driver.

- Less than 4" mounting depth
- 1" C-CAM gold dome tweeter
- 8" C-CAM driver.

- Less than 4" mounting depth
- 2 x 1" C-CAM gold dome tweeters
- 8" C-CAM driver.

- Certified for Extreme climate conditions (Salt Spray, UV stability, Water, Vibration, Anti-corrosion) **Front: IP55 Rear: IP4X**
- Stainless Steel "Trimless" grille
- Non-ferrous Samarium Cobalt magnets for grille attachment – Prevents rust and corrosion
- Neoprene barriers to prevent ingress of moisture
- Gold plated push terminals with silicone cover
- Stainless steel fixing screws with Neoprene covers
- Magnetic grille attachment
- Tri-Grip dog leg fixings
- Operating temperature range: -34 to 79°C / -29 to 174°F.

Gold plated push terminals with silicone cover:



Stainless steel fixing screws with Neoprene covers:







SUBWOOFERS

IN-WALL SUBWOOFER

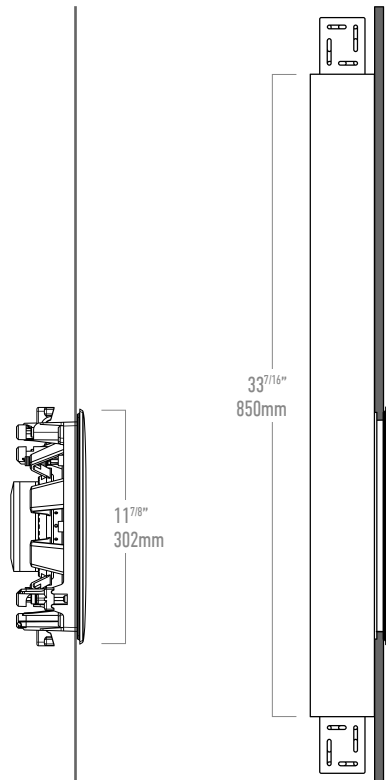

IWS-10 installed without IWB-10

IWS-10 installed with IWB-10



IWS-10 (In-Wall Subwoofer)

Cutout Dimensions:
11 x 11 x 3^{1/2}" / 280 x 280 x 90mm

- Less than 4" mounting depth
- 10" C-CAM RDT driver
- Ideally but not exclusively pairs with its IWB-10 back box
- Tri-Grip dog leg fixings.

IWB-10 (In-Wall Box)

Overall Dimensions:
33^{1/2} x 13^{13/16} x 3^{11/32}" / 850 x 351 x 85mm

- Designed to provide optimum performance for IWS-10
- Fits into standard 14" stud bays (16" centres)
- Heavy duty MDF construction
- Rugged laminated vinyl finish
- Pre-wired with external high quality push type terminals
- Supplied with mounting brackets for installation.

IWA-250 (Amplifier)

Overall Dimensions:
1^{3/4} x 17 x 10^{3/8}" / 43.7 x 432 x 263mm

- Class D power amplifier
- Heavy-duty 1U rack mount case
- Will power single or dual IWS-10s
- Switch mode power supply
- DSP controlled with advanced limiters
- <0.5W standby power consumption (ErP certified)
- DC short circuit protection, over-current and thermal protection
- Supplied with rack mounting brackets for installation.



IWS-10 square grille

CUSTOM SUBWOOFER

- Two, side mounted ABRs (auxiliary bass radiators) to increase output and reduce distortion
- Tuned for High SPL and impact
- High power digital Class-D amplifier delivering over 400W R.M.S
- IR sensor for remote control (Published feature codes)
- RS-232 for integration with system controllers (Published feature code)
- USB P.C. application for full feature adjustment and installer set-up
- LFE Balanced XLR Input and un-balance RCA
- Stereo RCA line level inputs
- Phase and power mode switches
- Auto standby (signal sensing) and 12V trigger
- 4 pre-set EQ's optimised for: Flat, Music, Movie and Impact with customisation using application
- Robust metal mesh grille
- Rigid MDF cabinet construction with durable vinyl finish.

CW8

(Long throw 8" C-CAM driver)



Cabinet Dimensions
(H x W x D):

10^{5/8} x 10^{1/4} x 10^{7/8}"
270 x 260 x 276mm

CW10

(Long throw 10" C-CAM driver)



12^{3/8} x 12 x 12^{5/8}"
315 x 305 x 320mm

CLG-W12 (Garden Subwoofer)



Overall Dimensions (H x W x D):
31^{7/8} x 14^{15/16} x 19^{7/8}"
810 x 380 x 505.5mm

- Long Throw 12" C-CAM driver
- Passive design with 70/100V and 4Ω tap for flexible system design
- High impact moulded cabinet - robust and waterproof
- Certified to IP67 rating
- Dark Brown finish to blend into garden environment
- Custom DSP filter settings for Crown CDi series
- Operating temperature range: -20 to 70°C / -4 to 158°F.





ACCESSORIES

SQUARE GRILLE OPTIONS

All-round performance in a square

Designed to suit contemporary interior styling, our updated square trimless grilles are available for numerous in-ceiling speakers (listed on Page 10). Only pre-packaged with the CWT series, sold separately for all other ranges.

Please refer to Page 10 for the full list of compatible speakers >



SOUNDFRAME FRAMELESS GRILLES (NEW)

ORIGINAL
SF1 On-Wall with original
frame and grille.
Scale 1:10 Approx.

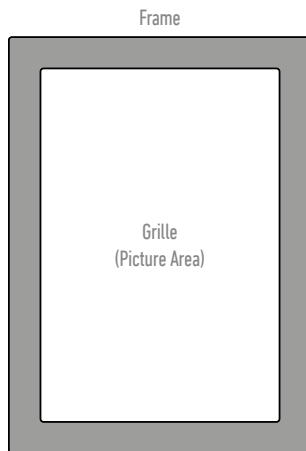

FRAMELESS
SF1 On-Wall with new
frameless grille.
Scale 1:10 Approx.

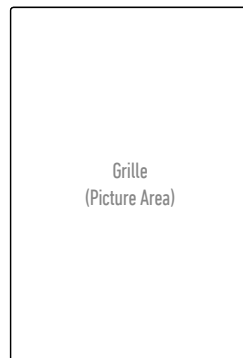

The extensive SoundFrame grille library is now available as a frameless option for all SoundFrame speaker models, as well as our custom made Bespoke Grille printing service.

CLG SERIES ACCESSORIES



^ CLG-MOUNT

< CLG-SPIKE R

Monitor Audio's CLG140 garden satellite speaker is a versatile outdoor solution. Whether floorstanding or wall or tree mounted, the CLG140 can be coupled with the CLG-SPIKE R or CLG-MOUNT to adapt to your requirements.

PRE-CONSTRUCTION BRACKETS

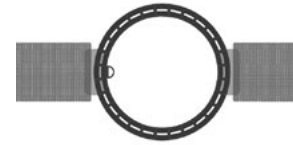

In-Ceiling Pre-Construction Bracket

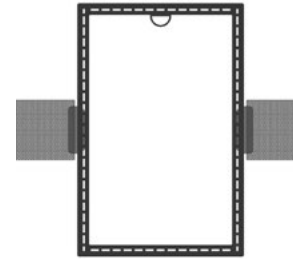

In-Wall Pre-Construction Bracket

- CB4:** CWT140, CWT240
- CB5:** CWT160
- CB6:** CSS230, CWT180, CT165, CT165-T2, CT265, CT265-FX, CT265-IDC, CP-CT150, AWC265, AWC265-T2
- CB8:** CT180, CT180-T2, CT280, CT280-IDC, CT380-IDC, CT380-FX, CP-CT260, PRO-80, AWC280, AWC280-T2
- CB10:** CP-CT380, CP-CT380IDC
- WB6:** WT165, WT265, CP-WT150
- WB8:** WT180, WT280, WT280-IDC, WT380-IDC, CP-WT260
- WB10:** CP-WT380, CP-WT380IDC
- WB12:** CP-IW260W, CP-IW460X
- WB4LCR:** CP-WT140LCR, CP-WT240LCR
- WB5LCR:** WT150-LCR, WT250-LCR
- PRO-IC65 CONSTRUCTION BRACKET:** PRO-65
- CB8-LV:** PRO-80LV

BACK-BOXES

A selection of in-wall and in-ceiling back-boxes, designed for installing in concrete. Suits various Monitor Audio CI models.

- CCB-R:** Internal volume 5.5L | CWT140, CWT240, CWT160, CT180, CT165, CT165-T2, CT265
- CCB-L:** Internal volume 8.5L | CT265-IDC, CT265-FX, CP-CT150, CP-CT260, CT180, CT180-T2, CT280
- WCB-L:** Internal volume 17L | WT165, WT180, WT280, WT280-IDC, WT380-IDC, CP-WT260



CCB-R



CCB-L



WCB-L



**FIREHOOD
(COMING SOON)**

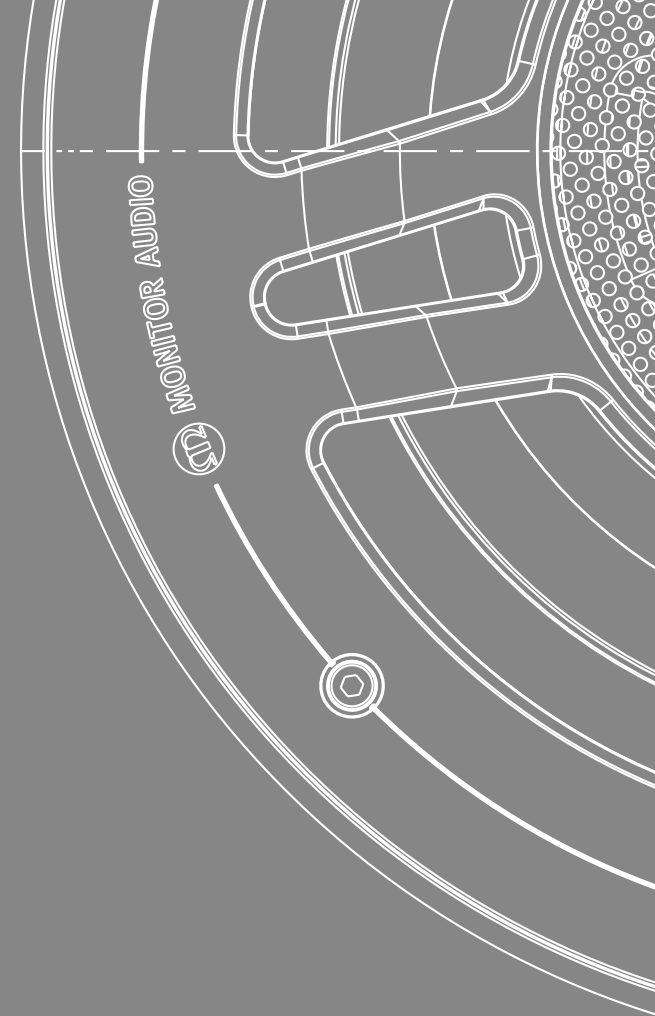

MONITOR AUDIO LTD

24 Brook Road, Rayleigh
Essex, SS6 7XJ
England

Tel: + 44 (0)1268 740580

Fax: + 44 (0)1268 740589

Email: info@monitoraudio.com

www.monitoraudio.com

Designed in the United Kingdom