

WOODPECKER CNC

Assembly instructions

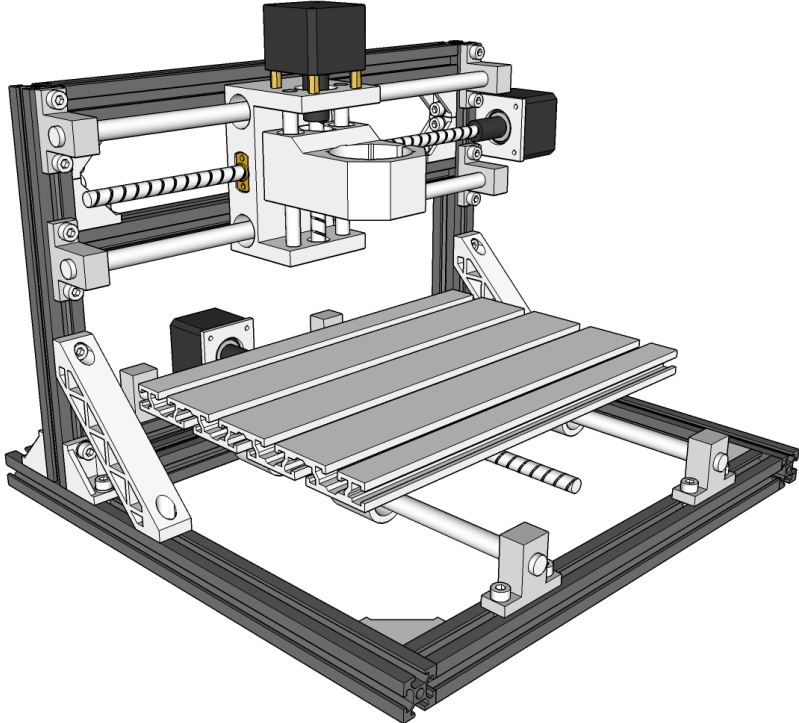

◆ • Component size:

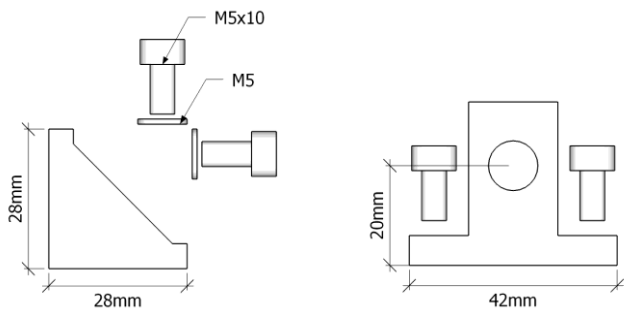
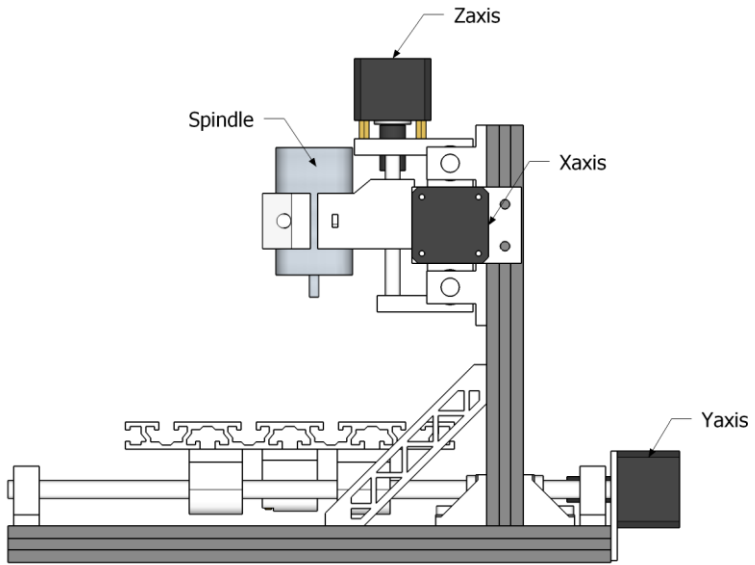

1. Frame installation

- base: 330mm×2、300mm×3、Corner pieces×6、M5*10×12、Spacer×12

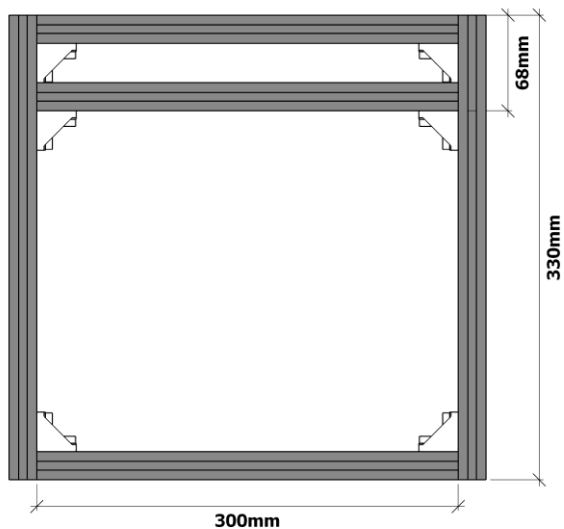

- Top frame: 220mm×2、300mm×2、Corner pieces×4、M5*10×8、Spacer×8

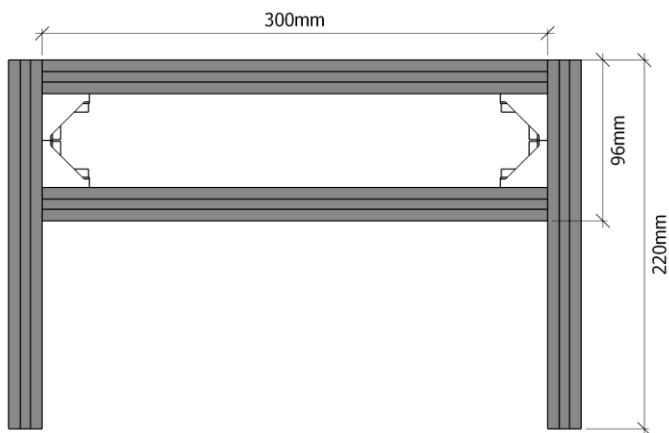

- Frame installation: Corner pieces $\times 6$, M5*10 $\times 16$, Spacer $\times 12$, Connector $\times 2$

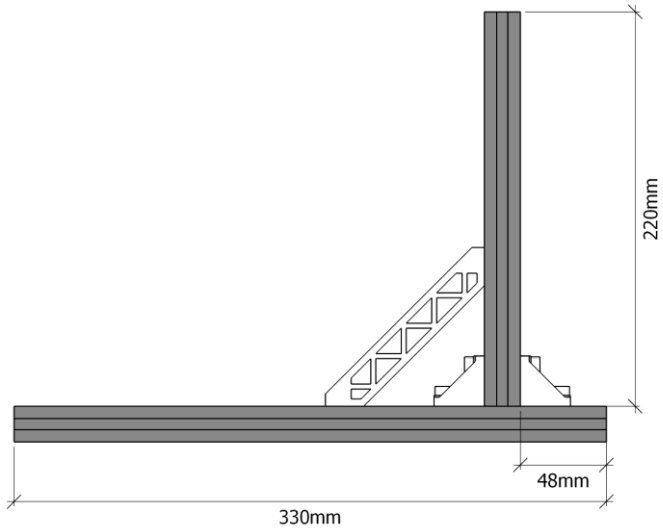

- axis support base dimensions 1:

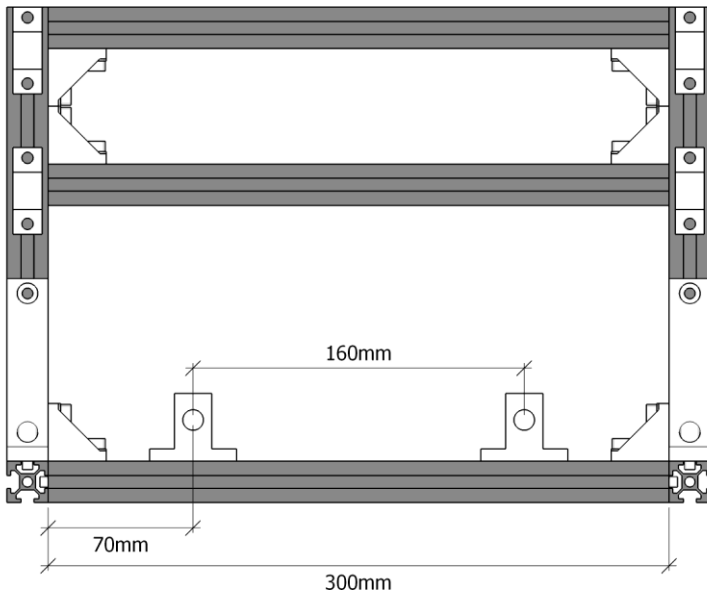

- axis support base dimensions 2:

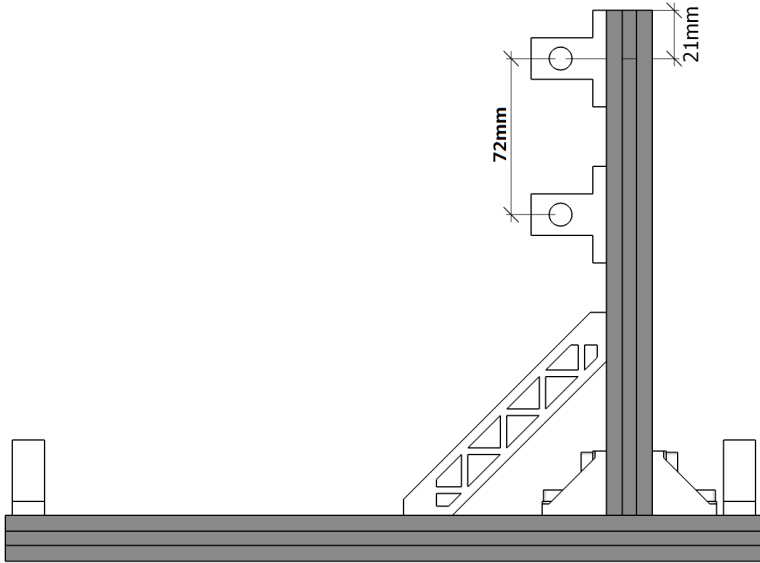

- Y-axis installation: M6*10×10、Slider×5、Mesa×1

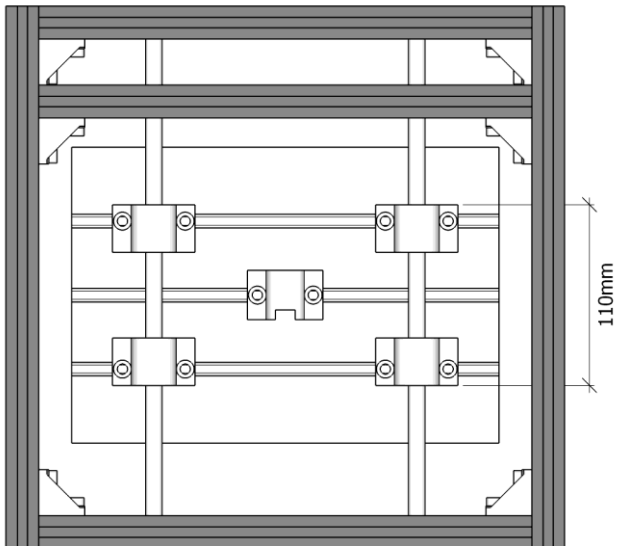

- stepper motor mounting

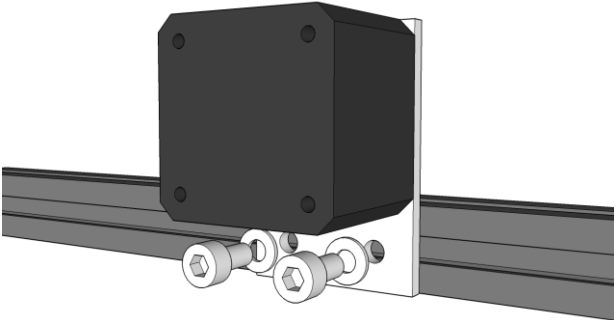
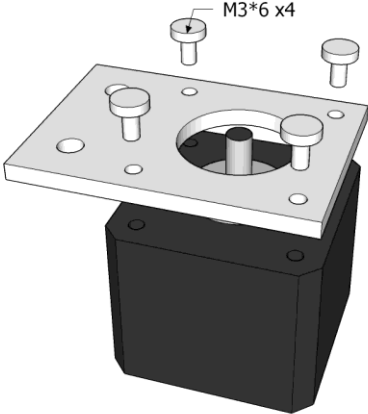

● XZ component installation

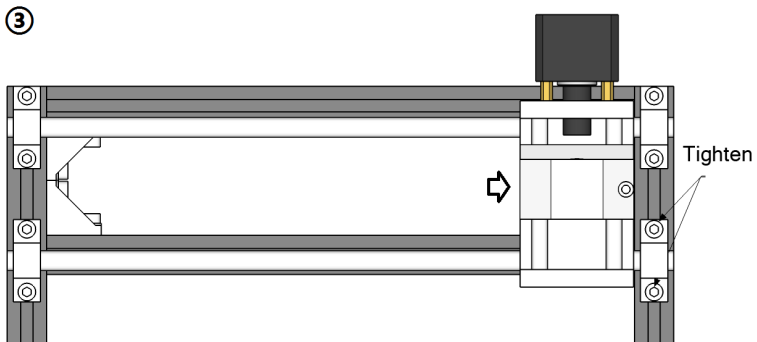
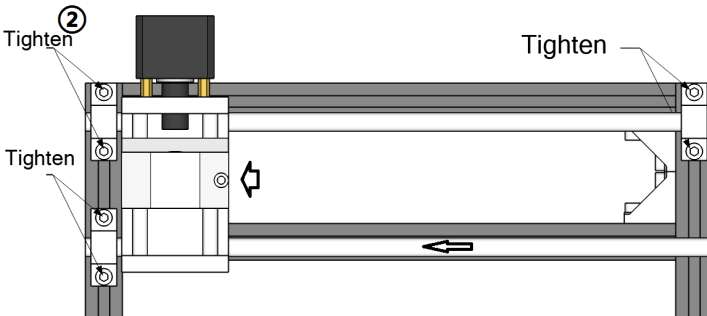
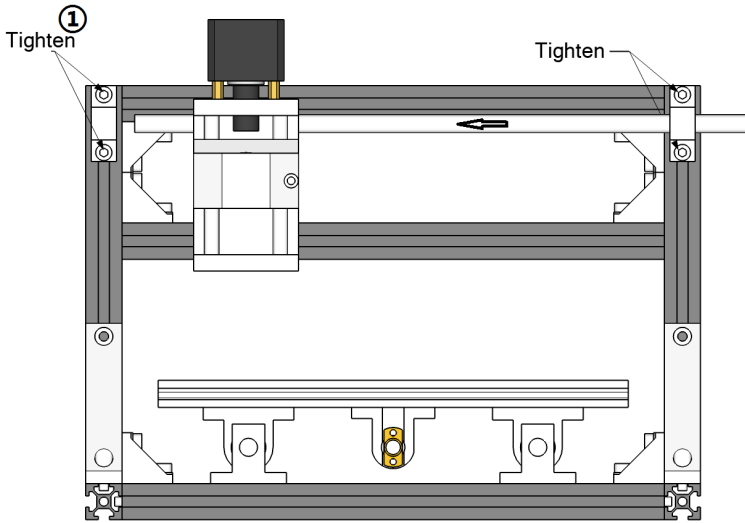

- screw assembly schematic

Xaxis

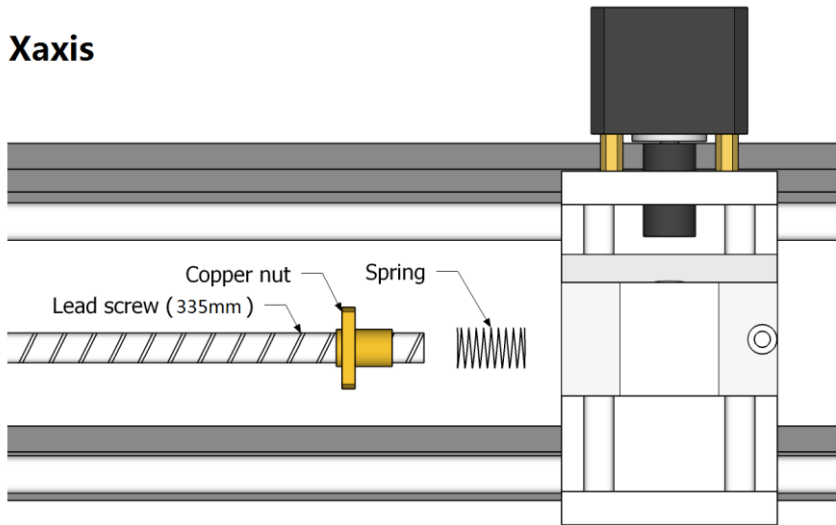

Yaxis

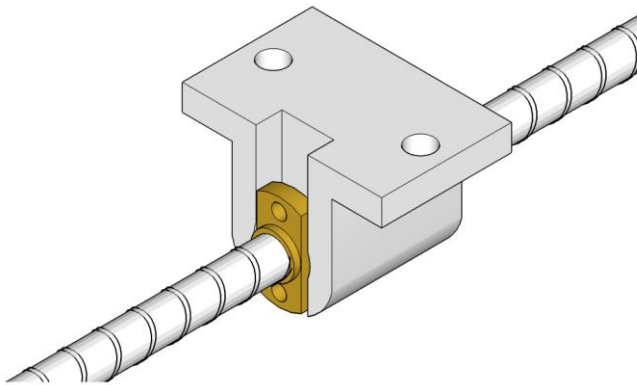
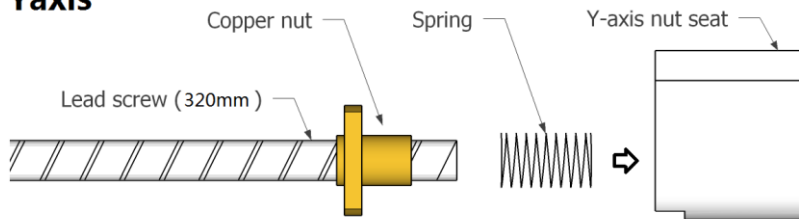

- Coupling assembly:

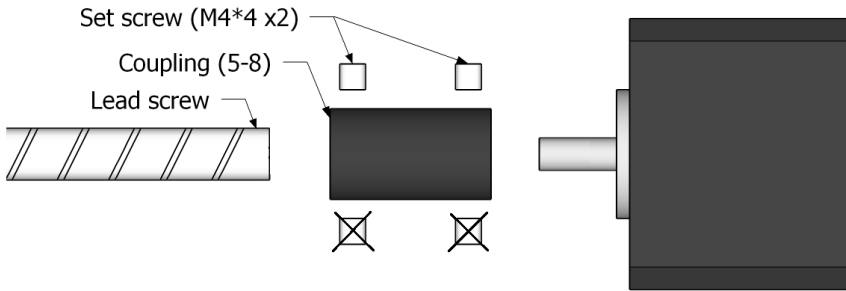

- Bearing installation:

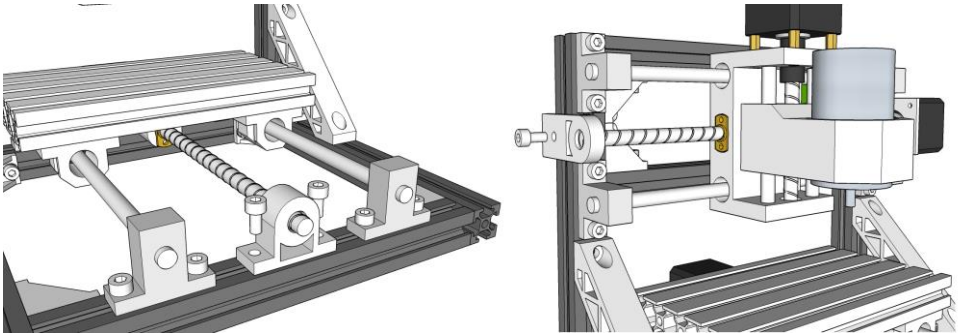

- Install control board

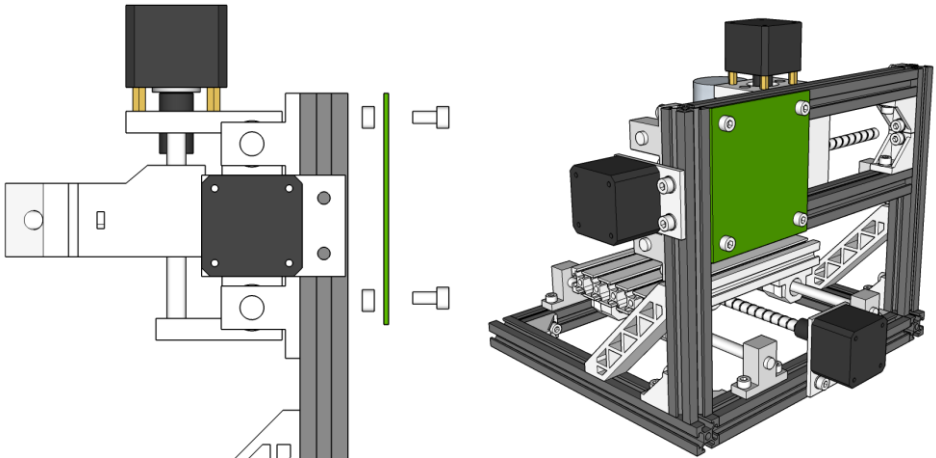

Wiring diagram:

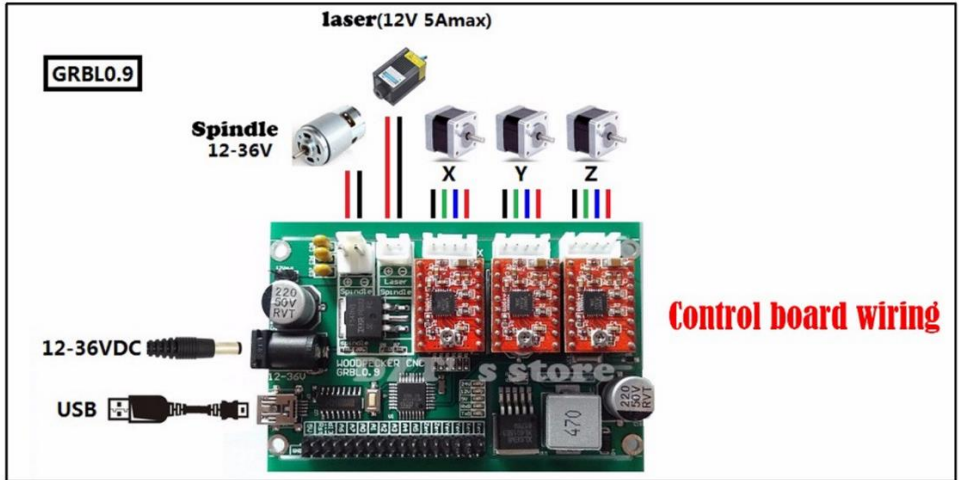

If you have any problems , please contact with us .
Our email address :