



C H O O S E R E D S A F E T Y

DOUBLE PROTECTION IN ONE SINGLE SYSTEM

Pantera Air System, the portable system that simultaneously protects eyes and respiratory tract.



Pantera Air System

The ideal protection in all welding situations

Pantera Air System is a device that guarantees excellent respiratory tract and face protection, for added safety and comfort during welding. Portable and comfortable, it is ideal in all operating situations.

In indoor environments it can be combined with a centralized suction system for total protection, in outdoor environments it is the ideal solution, thanks to its power supply with long-lasting batteries, up to 8 continuous hours.

THE HOSE

Corrugated hose with flameproof cotton cover and bayonet couplings.

THE HELMET

Pantera auto-darkening helmet, equipped with digital controls with large viewing area (100x60 mm) and darkening time less than 0.1 ms. Safety is guaranteed by 4 optical sensors.

THE SUPPORT

Practical, comfortable and adjustable shoulder strap and padded belt.

THE VENTILATION SYSTEM

The blower unit is the heart of the system.

- 3-speed air flow for optimal handling in all working conditions.
- Filter efficiency of 99.99% = 0.3 µm.
- Full and intuitive digital display.
- System adjustable wearing gloves.

Pantera Air System complies with the following regulations

Respirator approval

- EN 12941:1998 + A2:2008

Helmet compliance

- EN 175
- EN 379

PANTERA AIR SYSTEM

Features and functions



PANTERA AIR SYSTEM OPERATION

The Pantera Air System aspirates air from the environment and, filtering it with prefilters and filters, conveys a clean airflow to the head, ensuring a clean area for the respiratory tract, and therefore a good oxygenation.



COMPOSITION OF THE FILTER SYSTEM

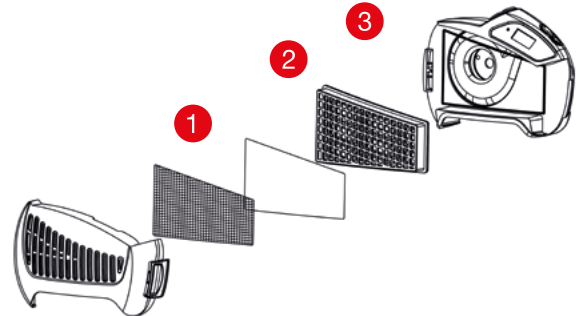

- 1 Spark arrester to block coarse powders.
- 2 Prefilter to block powders in general.
- 3 Specific filter for thin particles with a filter efficiency of 99.99% = 0.3 µm.

Filters should be replaced in relation to hours of use. We recommend replacing them with a higher frequency to ensure a good clean air flow. In case of negligence in the replacement of the filters, the system goes into alarm signaling an inadequate airflow.

LCD DISPLAY FUNCTIONS

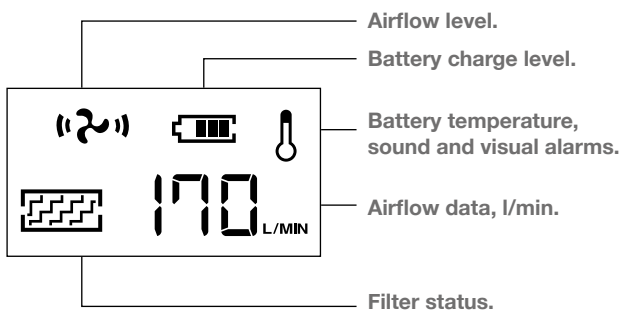

CE EN 175 - EN 379 - EN 12941 TH2



APPLICATIONS



filter efficiency of 99.99% = 0.3 µm
wide viewing area
4 arc sensors



1/1/1/1 OPTICAL CLASS	mm 100 x 60 VIEWING AREA	mm 114 x 133 FILTER DIMENSIONS	4 SENSORS	DIGITAL CONTROLS	DIN 4 LIGHT STATE	TO FROM DIN 4 / 9÷13 SHADE RANGE	UV/IR DIN 15 UV/IR PROTECTION	< 0,08 ms SWITCHING TIME	0,1÷0,9 s DELAY
SENSITIVITY	E POWER SUPPLY	CR2450 Li REPLACEABLE BATTERIES	LOW BATTERY INDICATOR	g 800 NET WEIGHT	PAPR				



DOUBLE PROTECTION IN ONE SINGLE SYSTEM

PANTERA AIR SYSTEM TECHNICAL DATA

Filter type	TH2 P R SL
Filter efficiency level	99,99% = 0,3 µm
Airflow level	1 st speed: 170 l/min
	2 nd speed: 200 l/min
	3 rd speed: 230 l/min
Noise level	Max 70 dB
Belt size	900 ÷ 1300 mm
Blower unit size	240 x 165 x 70 mm
Blower unit weight	1,29 Kg
Battery model	Rechargeable Li-ION 440 mAh
Battery life	1 st speed > 8 h
	2 nd speed > 6 h
	3 rd speed > 4 h
Battery charge time	3,5 h
Number of battery recharges	500
Information on the digital display	Air flow rate and data
	Battery level
	Filter status
Usage temperatures	-5°C +55°C
Storage temperatures	-10°C +55°C

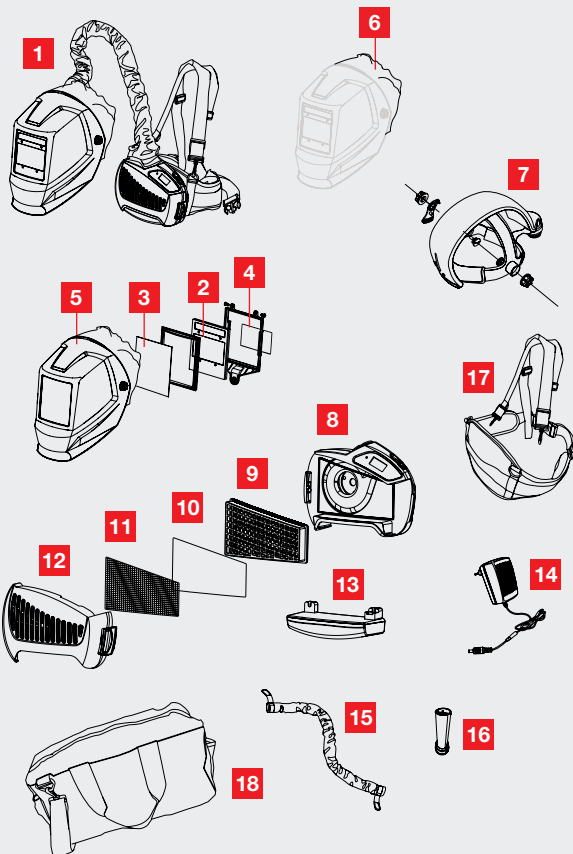

PART NUMBERS AND SPARE PARTS

	CODE	DESCRIPTION	
1	MSC000440	PANTERA AIR SYSTEM air-purifying system + PANTERA auto-darkening helmet	1
2	SPL000430	PANTERA filter	1
3	LVE000238	External protection plate 114 x133x1 mm	1
4	LVE000237	Internal protection plate 106x66x1 mm	1
5	SPL000391	Helmet shell + throat protection + external protection plate for PANTERA AIR SYSTEM	1
6	SPL000390	Cotton throat protection	1
7	VCE000695	Air conveyor + headgear	1
8	MU0360	Blower Unit	1
9	SPL000380	Filter	4
10	SPL000381	Prefilter	10
11	SPL000382	Spark arrestor	10
12	BW0755	Filter cover	1
13	SPL000383	Rechargeable Li-ION battery	1
14	SPL000388	Charger 100-240V	1
15	SPL000384	Flame retardant corrugated air pipe 1 m	1
16	SPL000387	Flowmeter	1
17	SPL000385	Padded belt + shoulder strap	1
18	SPL000389	Black canvas bag	1

Italy
Ph. +39 0444 739800
Fax +39 0444 739899

Export
Ph. +39 0444 739900
Fax +39 0444 739999

info@trafimet.com

© 2019 Trafimet Group SpA a socio unico
Edition 12/2019
Code EA1335

Distributor