



Engine evolution  
**Euro6c**  
Even less emissions

## TECHNICAL DATA

GENERAL		B 200 H EURO 6 - 4x2x2	B 200 H EURO 6 - 4x2x4	B 200 H EURO 6 - 4x4x4
Maximum authorised weight	kg	5000	5000	5000
Unladen weight*	kg	3400	3500	3500
Total height	mm	2020	2020	2020
Total width (without brushes)	mm	1300	1300	1300
Total length (with brushes)	mm	4195	4195	4195
<b>ENGINE</b>				
Make	-	VM MOTORI	VM MOTORI	VM MOTORI
Model	-	R754 EU6	VM R754 EU6	VM R754 EU6
Power	kW	68	68	68
Torque	N-m@rpm	380@1100	380@1100	380@1100
No. cylinders	-	4	4	4
Consumption	l/h	5,3	5,3	5,3
<b>DRIVING</b>				
Maximum speed	km/h	40	40	40
Maximum operation speed	km/h	25	25	25
Gradeability (at full load)	%	27	37	37
External turning radius	mm	3300	2700	2700
Suspension	-	Hydraulic shock absorber	Hydraulic shock absorber	Hydraulic shock absorber
Rear suspension	-	Hydraulic shock absorber	Hydraulic shock absorber	Hydraulic shock absorber
Tyres	-	225/70 R15	225/70 R15	225/70 R15
<b>WASTE HOPPER</b>				
Capacity	l	2000	2000	2000
Material	-	Stainless steel	Stainless steel	Stainless steel
Tipping height	mm	1580	1580	1580
Tipping width	mm	1200	1200	1200
Turbine capacity	m <sup>3</sup> /h	14.000	14.000	14.000
<b>SWEEPING SYSTEM</b>				
No. brushes	-	2 - 3	2 - 3	2 - 3
Port and arms material	-	Stainless steel	Stainless steel	Stainless steel
Effective maximum width of sweep	mm	2500/2800	2500/2800	2500/2800
Sprinklers	-	11	11	11
4-STAR PM2.5/10	-	X	X	X
<b>WATER TANK</b>				
Capacity	l	300	300	300
Material	-	Rotomolding HDPE	Rotomolding HDPE	Rotomolding HDPE
Water pump flow	l/min	12,5	12,5	12,5
Water pump pressure	bar	2,5	2,5	2,5

## DIMENSIONS

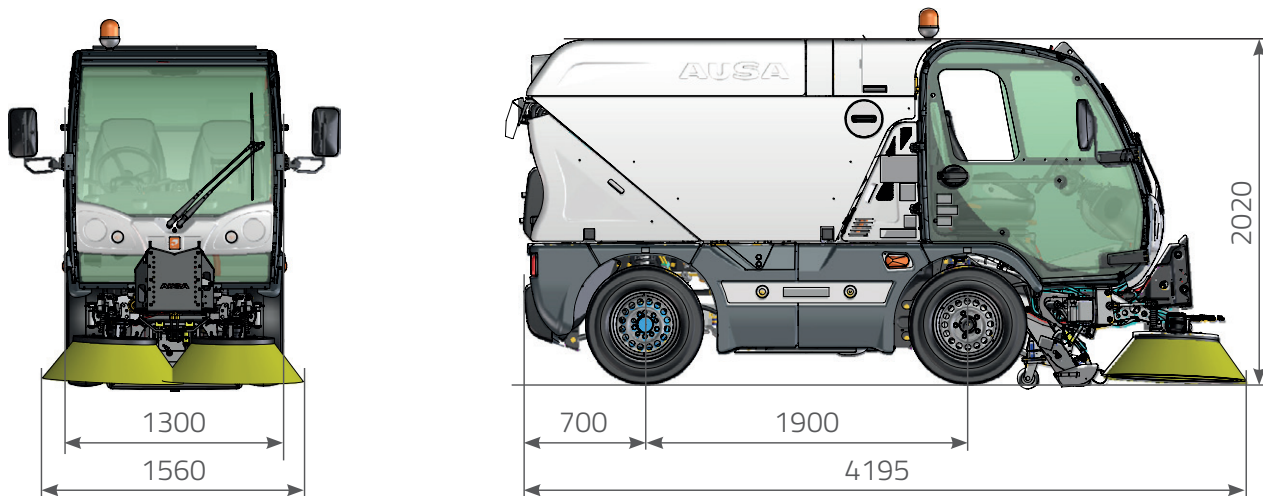

## iLINK SYSTEM

The **iLink concept** of our B200H sweeper enables intensive use throughout the year; not only does it sweep with maximum efficiency and productivity but it can also be used as a **cold water flusher, hot water scraper** (both with a water capacity of 2,000 litres) or as a **winter maintenance unit** with its 1.1 m<sup>3</sup> spreader and its snow brush or plough.

## OPTIONAL ATTACHMENTS

### iLink option

1,500 mm snow plough with hydraulic regulation and lateral tilt

Snow brush sweeper, width 1,500 mm

Aluminium cargo bed (1,840 x 1,300 x 420 mm) with trilateral hydraulic tilting

Detachable hydraulic salt spreader

Flusher with reinforced plastic tank. Cold water

Flusher with reinforced plastic tank. Hot water

Scraper head with hot water

Simple spray bar. Cold water

Simple spray bar. Hot water

2,000l water tank for cold water flushing

2,000l water tank for hot water scraping

Support kit for assembly/disassembly, maintenance and storage of the sweeper tank

Support kit for assembly/disassembly, maintenance and storage of water flushing tank

Support kit for assembly/disassembly, maintenance and storage of cargo bed

**excelway**<sup>®</sup>



[www.excelway.eu](http://www.excelway.eu)

Products are subject to modifications without prior notice. Images throughout the spec sheet may refer to non-standard machines or non-available configurations depending on models.

AUSA's logo and corporate identity are property of the Company, they cannot be used without authorization.