

X GÖRÜNÜŞÜ

BENT AXIS PISTON PUMP

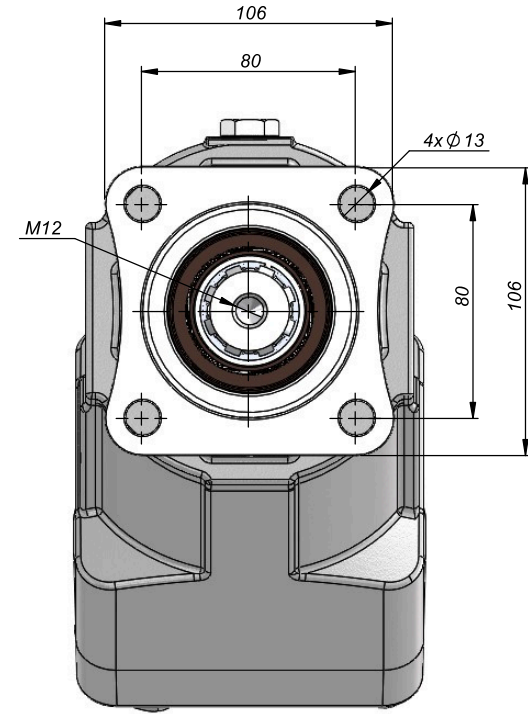
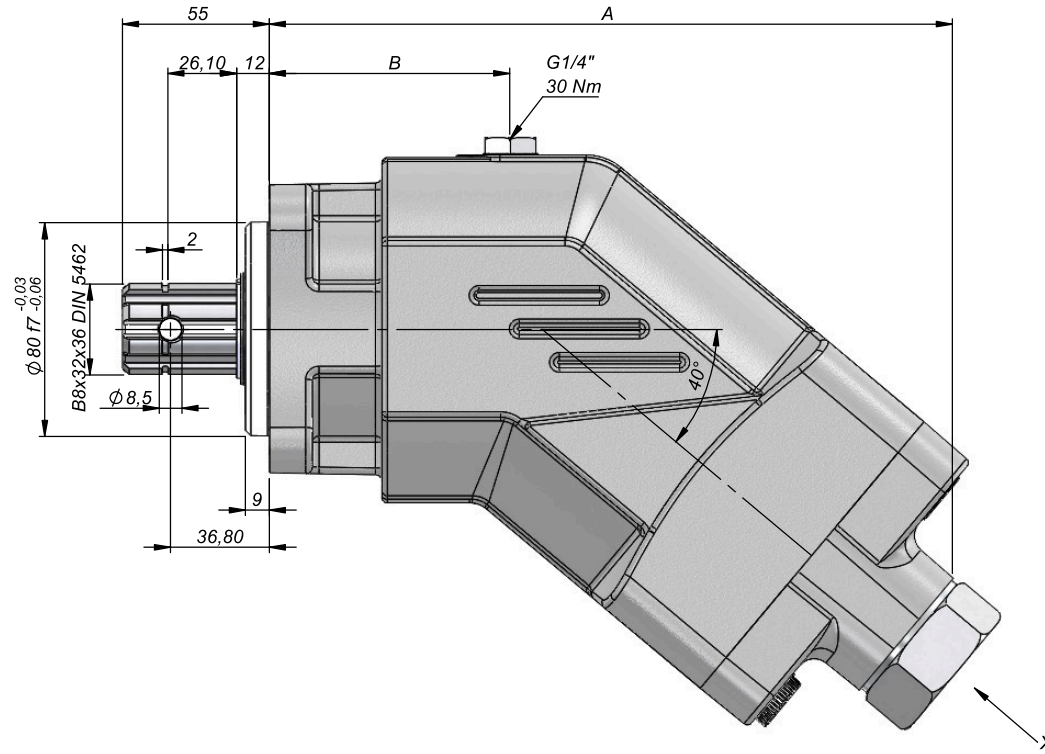
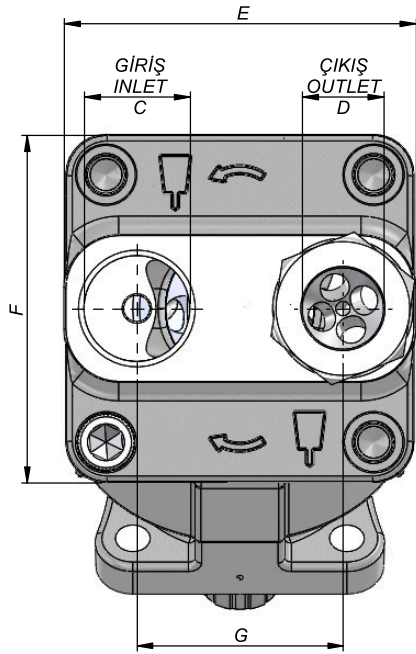

Tapaların Sıkma Torku Tightening Torque Of The Plugs

G1/2"	55-65Nm
G3/4"	90-100Nm
G1"	135-160Nm
G1 1/4"	200-230Nm

Kod / Code	İletim Hacmi Displacement (cm ³ /rev)	Max.Sürekli Basınç Max.Continuous Pressure	Maks.Anlık Basınç Max.Peak pressure	Maks. Hız Max. speed (RPM)		A (mm)	B (mm)	C (mm)	D (mm)	E (mm)	F (mm)	G (mm)	
				nom	max								
APA023SF111 APA023SF121	23	350	400	3050	4300	180	58	G3/4"	G1/2"	89	89	52	
APA032SF111 APA032SF121	32			2750	3900								
APA045SF111 APA045SF121	45			2650	3800	210	78	G1"	G3/4"	108,70	108,70	59	
APA056SF111 APA056SF121	56			2550	3700	218	80						
APA063SF111 APA063SF121	63			2200	3200	245	94	G1 1/4"	G1"	110,50	108	64	
APA080SF111 APA080SF121	80			2150	3100								
APA107SF111 APA107SF121	107			250	300	2000	2800	255	G1 1/4"	G1"	127	118	69
APA125SF111 APA125SF121	125					1750	2500				131,60	130	77

*(1) - Left- Sol
*(2) - Right- Sağ



KAZEL
HYDRAULIC EQUIPMENTS