

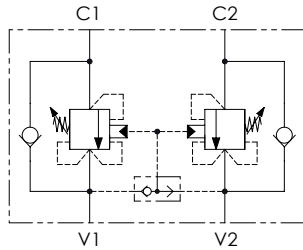

CODICE ORDINAZIONE
ORDERING CODE

01	02	03	04	05
VBCC			S	

SCHEMA IDRAULICO / HYDRAULIC CIRCUIT



PERFORMANCES

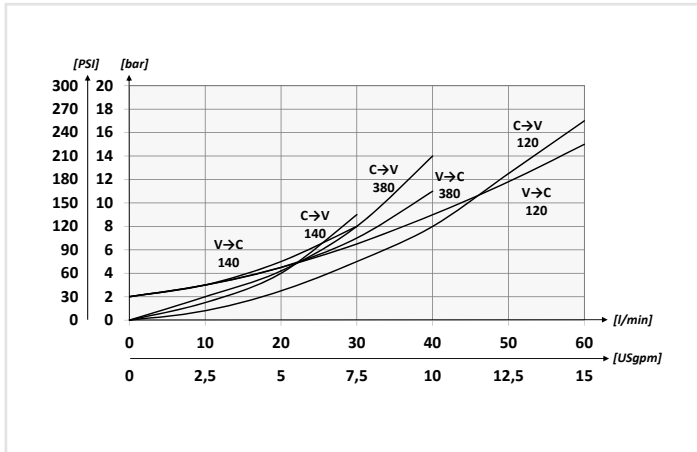

01	VALVOLE DI BILANCIAMENTO DOPPIE PER CENTRO CHIUSO (DOUBLE COUNTERBALANCE VALVES FOR CLOSED CENTER)			VBCC	
02	DIMENSIONE (SIZE)	BSPP 1/4		140	
		BSPP 3/8		380	
		BSPP 1/2		120	
03	MOLLA (SPRING) 30/210 bar (435/3045 PSI)	Rp 1:4.25	78 bar/al giro (1131 PSI/turn)	Taratura standard (Std. setting) Q=5 l/min 200 bar (2900 PSI)	1
		Rp 1:8.75	160 bar/al giro (2320 PSI/turn)		
03	MOLLA (SPRING) 60/350 bar (870/5075 PSI)	Rp 1:4.25	135 bar/al giro (1958 PSI/turn)	Taratura standard (Std. setting) Q=5 l/min 350 bar (5075 PSI)	2
		Rp 1:8.75	160 bar/al giro (2320 PSI/turn)		
04	MATERIALE (MATERIAL)	Acciaio + zincatura (Steel + zinc-plating)		S	
05	RAPPORTO DI PILOTAGGIO (PILOT RATIO)	1:4.25 Standard		/	
		1:8.75		8	

DATI TECNICI / TECHNICAL DATA

Olio idraulico - Mineral oil	ISO 6743/4 (DIN 51524)
Viscosità olio - Oil viscosity	15-250 mm²/s (15 to 250 cSt)
Classe di contaminazione max con filtro Max contamination index with filter	ISO 4406:1999 Classe 19/17/14
Temperatura dell'olio - Oil temperature	-20°C +80°C -4°F +176°F
Temperatura ambiente - Environment temperature	-20°C +50°C -4°F +122°F
È indispensabile l'utilizzo di un filtro per proteggere la valvola (filtrazione consigliata 15 µm) It is necessary a filter use to protect the valve (advised filtration 15 µm)	

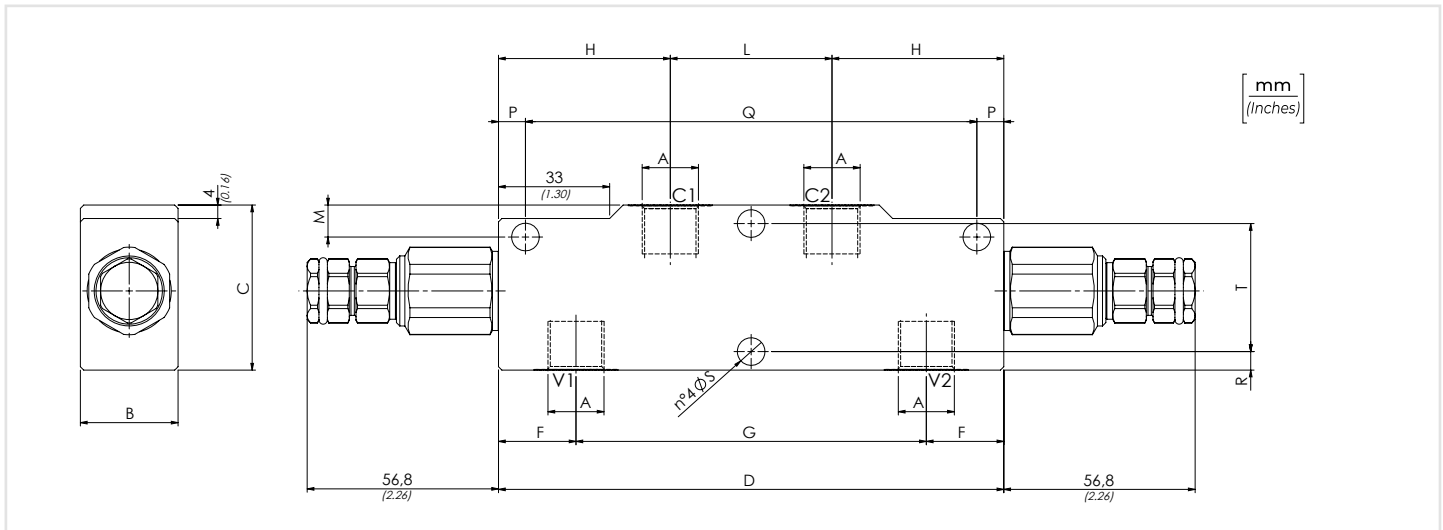

CARATTERISTICHE TECNICHE / TECHNICAL CHARACTERISTICS

TIPO TYPE	A	PORTATA MAX MAX FLOW l/min-USgpm	PRESSIONE MAX MAX PRESSURE bar-PSI	B	C	D	F	G	H	L	M	P	Q	R	S	T	PESO APPROX APPROX WEIGHT kg-lbt	
VBCC140	BSPP 1/4	30 (8)	350 (5075)	29 (1.14)	49 (1.93)	150 (5.91)	23 (0.91)	104 (4.09)	51 (2.01)	48 (1.89)	10 (0.39)	8 (0.31)	134 (5.28)	5,5 (0.22)	8,2 (0.32)	38 (1.50)	1,68 (3.70)	
VBCC380	BSPP 3/8	40 (10.5)			59 (2.32)		21 (0.83)	108 (4.25)						12 (0.47)		7,5 (0.29)	43 (1.69)	1,66 (3.66)
VBCC120	BSPP 1/2	60 (16)																