



Vakuumpumpen

Vacuum pumps

Pompes à vide

Pompe per vuoto

V-VWZ (14)

V-VWZ 702 (14)

V-VWZ 1002 (14)

V-VWZ 1202 (14)

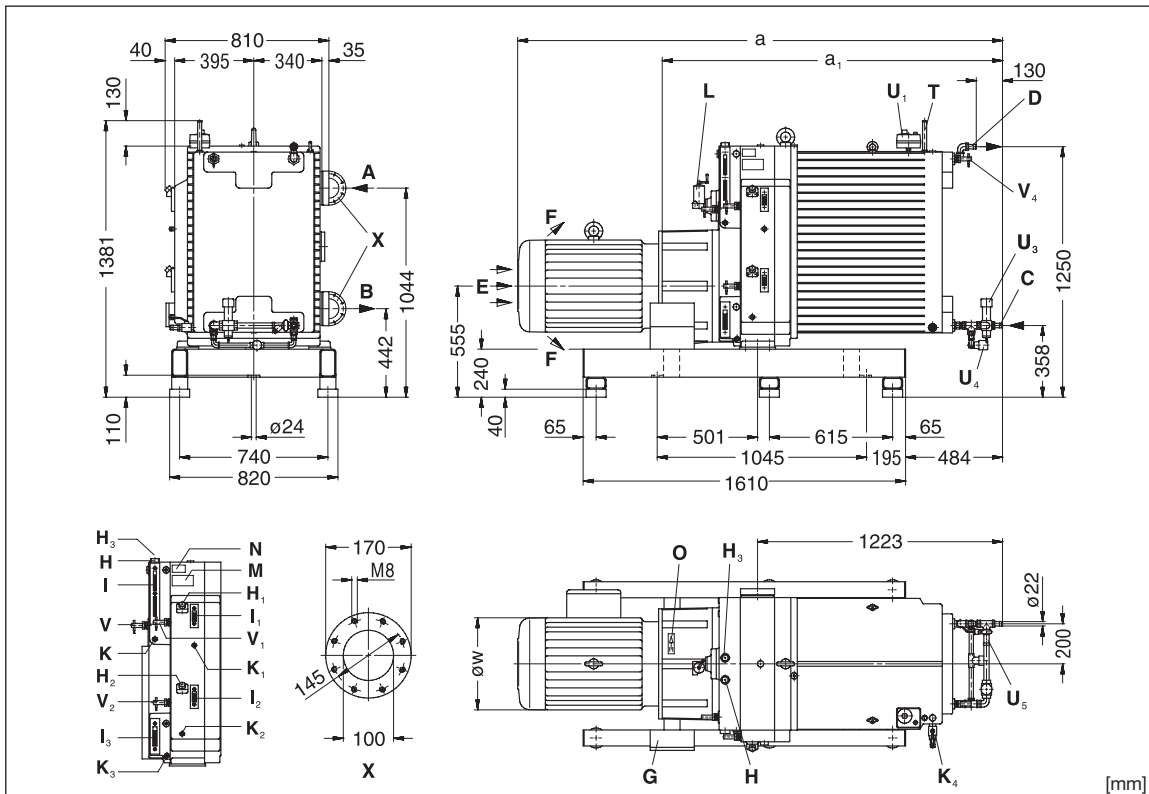

[mm]

A	Vakuum-Anschluss	Vacuum connection	Raccord du vide	Attacco vuoto
B	Abluft-Austritt	Exhaust	Refolement	Scarico aria
C	Kühlwassereintritt	Cooling water inlet	Entrée eau refroidissement	Entrata acqua di raffreddamento
D	Kühlwasseraustritt	Cooling water outlet	Sortie eau de refroidissement	Uscita acqua di raffreddamento
E	Kühlluft-Eintritt	Cooling air entry	Entrée air refroidissement	Entrata aria di raffreddamento.
F	Kühlluft-Austritt	Cooling air exit	Sortie air refroidissement	Uscita aria di raffreddamento
G	Klemmenkasten	Terminal box	Boîte à bornes	Morsetteria
H	Öleinfüllstelle Frischöl	Fresh oil filling point	Point de rempliss. d'huile neuve	Punto di riempim. olio fresco
H ₁	Öleinfüllstelle Lager ND-Stufe	Oil filler bearing LP-stage	Rempliss. d'huile roulem. E.P.	Foro riempim. olio cuscin. ND
H ₂	Öleinfüllstelle Lager HD-Stufe	Oil filler bearing HP-stage	Rempliss. d'huile roulem. E.S.	Foro riempim. olio cuscin. HD
H ₃	Öleinfüllstelle Getriebe	Oil filler gear box	Rempliss. d'huile engrenage	Foro riempim. olio ingranaggi
I	Ölkontrolle Frischöl	Oil check fresh oil	Contrôle d'huile neuve	Spia controllo olio fresco
I ₁	Ölkontrolle Lager ND-Stufe	Oil check bearing LP-stage	Contrôle d'huile roulem. E.P.	Spia controllo olio cuscin. ND
I ₂	Ölkontrolle Lager HD-Stufe	Oil check bearing HP-stage	Contrôle d'huile roulem. E.S.	Spia controllo olio cuscin. HD
I ₃	Ölkontrolle Getriebe	Oil check gear box	Contrôle d'huile engrenage	Spia controllo olio ingranaggi
K	Ölablassstelle Frischöl	Fresh oil drain point	Point de vidange d'huile neuve	Punto scarico olio fresco
K ₁	Ölablassstelle Lager ND-Stufe	Oil drain bearing LP-stage	Vidange d'huile roulem. E.P.	Scarico olio cuscinetti ND
K ₂	Ölablassstelle Lager HD-Stufe	Oil drain bearing HP-stage	Vidange d'huile roulem. E.S.	Scarico olio cuscinetti HD
K ₃	Ölablassstelle Getriebe	Oil drain gear	Vidange d'huile engrenage	Scarico olio ingranaggi
K ₄	Kühlwasserablass	Cooling water drain	Purge d'eau refroidissement	Scarico acqua di raffreddamento
L	Ölschmierpumpe	Oil metering pump	Pompe de lubrification	Pompa dell'olio
M	Ölempfehlungsschild	Oil type plate	Plaque comm. d'huiles	Targhetta oli consigliati
N	Datenschild	Data plate	Etiquette caractéristique	Targhetta dati
O	Drehrichtungsschild	Direction of rotation	Flèche sens rotation	Targhetta senso rotazione
T	Thermometer-Kühlwasser	Thermometer-Cooling water	Thermomètre-Eau refroidiss.	Termometro-Acqua refriger.
U ₁	Sicherheitsthermostat	Safety thermostat	Thermostat de sécurité	Termostato di sicurezza
U ₃	Thermostat. Wasserventil	Thermostatic water valve	Soupape d'eau thermostatique	Valvola d'acqua termostatica
U ₄	Selbstschlussdurchgangsventil	Self closing priming valve	Vanne auto obturante	Valvola autobloccante
U ₅	Schmutzfänger	Dirt drap	Séparateur de particules	Filtro antisporcizia
V	Niveauwächter-Frischöl	Level switch fresh oil	Contacteur niveau huile neuve	Sonda di livello olio fresco
V ₄	Niveauwächter-Kühlwasser	Level switch cooling water	Contacteur niveau eau refroidis.	Sonda di livello acqua raffredd.
X	Flansch DN 100 DIN 28404	Flange DN 100 DIN 28404	Bride DN 100 DIN 28404	Flangia DN 100 DIN 28404
V ₁	Zubehör Niveauwächter Lager ND-Stufe	Optional extras Level switch bearing LP-stage	Accessoires Cont. niv. d'huile roulem. E.P.	Accessori Sonda di livello cuscinetti ND
V ₂	Niveauwächter Lager HD-Stufe	Level switch bearing HP-stage	Cont. niv. d'huile roulem. E.S.	Sonda di livello cuscinetti HD

D 134

2.2.98

**Gardner Denver
Schopfheim GmbH**

Postfach 1260
79642 SCHOPFHEIM
GERMANY

Fon +49 7622 / 392-0

Fax +49 7622 / 392-300

e-mail: er.de@
gardnerdenver.com

www.gd-elmorietschle.com

V-VWZ (14)	702	1002	1202			
[mm]	a / a ₁	2297 / 1669 (18,5 - 22 kW)	2402 / 1699 (30 kW)	2489 / 1699 (37 kW)		
	øw	360	360	431	431	489

V-VWZ (14)		702		1002		1202	
m³/h	50 Hz	700		1000		1200	
	60 Hz	840		1200		1440	
mbar (abs.)•		0,5					
3~	50 Hz	400/690V ± 10%					
	60 Hz	380/660V					
kW	50 Hz	18,5	22,0	22,0	30,0	30,0	37,0
	60 Hz	22,2	26,4	26,4	36,0	36,0	44,4
A	50 Hz	36/20,8	43/24,8	43/24,8	58/33,5	58/33,5	73/42
	60 Hz	#	#	#	#	#	#
min⁻¹	50 Hz	950					
	60 Hz	1140					
dB(A)	50 Hz	78		79		81	
	60 Hz	79		80		82	
kg		1645	1705	2279	2400	2510	2550
l (H)	min. / max	3 / 21					
I/h (H)	50 Hz / 60 Hz	0,342 / 0,410		0,760 / 0,912		0,949 / 1,138	
I (H₁) / I (H₂) / I (H₃)		3,5 / 4,5 / 7,0					
I/h (Y)	25° / 35° / 45°	600 / 340 / 190		1100 / 600 / 240		1265 / 690 / 276	

m³/h	Saugvermögen	Capacity	Débit	Portata
mbar (abs.)•	Enddruck	Ultimate vacuum	Pression limite	Pressione finale
mbar (abs.)	Ansaugdruck	Suction pressure	Pression d'aspiration	Pressione di aspirazione
3~	Motorausführung	Motor version	Exécution moteur	Esecuzione motore
kW	Motorleistung	Motor rating	Puissance moteur	Potenza motore
A	Stromaufnahme	Current drawn	Intensité absorbée	Corrente nominale
min⁻¹	Drehzahl	Speed	Vitesse rotation	Numero giri
dB(A) → DIN 45635	Mittlerer Schalldruckpegel	Average noise level	Niveau sonore moyen	Rumorosità media
kg	Max. Gewicht	Maximum weight	Poids maxi.	Peso massimo
l (H)	Frischölvorrat min./max.	Fresh oil capacity min./max.	Réserve d'huile min./max.	Scorta olio fresco min./mass.
I/h (H)	Frischölverbrauch	Fresh oil consumption	Consommation d'huile neuve	Consumo d'olio fresco
I (H₁)	Öleinfüllmenge Lager ND-Stufe	Oil capacity LP-stage	Charge d'huile roulements E.P.	Quantità olio cuscinetti ND
I (H₂)	Öleinfüllmenge Lager HD-Stufe	Oil capacity HP-stage	Charge d'huile roulements E.S.	Quantità olio cuscinetti HD
I (H₃)	Öleinfüllmenge Getriebe	Oil capacity gear	Charge d'huile engrenage	Quantità olio ingranaggi
I/h (Y)	Kühlwasserverbrauch (15°C Eintrittstemperatur bei Wasseraustrittstemperatur °C)	Cooling water consumption (15°C inlet temperature at outlet water temperature °C)	Consommation eau refroidiss. (15°C température d'entrée en température de sortie °C)	Consumo acqua raffreddamento (15°C temperature d'ingresso a temperature di uscita °C)

Zubehör Flüssigkeitsabscheider Rückschlagventil Stern-Dreieck-Schaltgerät Vakuum-Schalter / Vakuummeter Vakuumdichter Staubabscheider 2/2-Wege-Magnetventil Ölnebelabscheider Spülmittelreinrichtung	Optional extras Liquid separator Non return valve Star-Delta starter Vacuum switch / Vacuum gauge Dust separator vacuum tight 2/2-way solenoid valve Oil mist separator Flushing unit	Accessoires Séparateur de liquide Clapet anti-retour Démarreur étoile triangle Commutateur vide / Vacuomètre Filtre séparateur étanche Électrovanne 2/2 voies Séparateur brouillard d'huile Dispositif produit rinçage	Accessori Separatore di liquido Valvola di non ritorno Avviamento stella-triangolo Interruttore a vuoto / Manovuotometro Separatore polveri ermetico Elettrovalvola a 2/2 vie Separatore fumi olio Dispositivo fluido di solvente
--	---	--	---

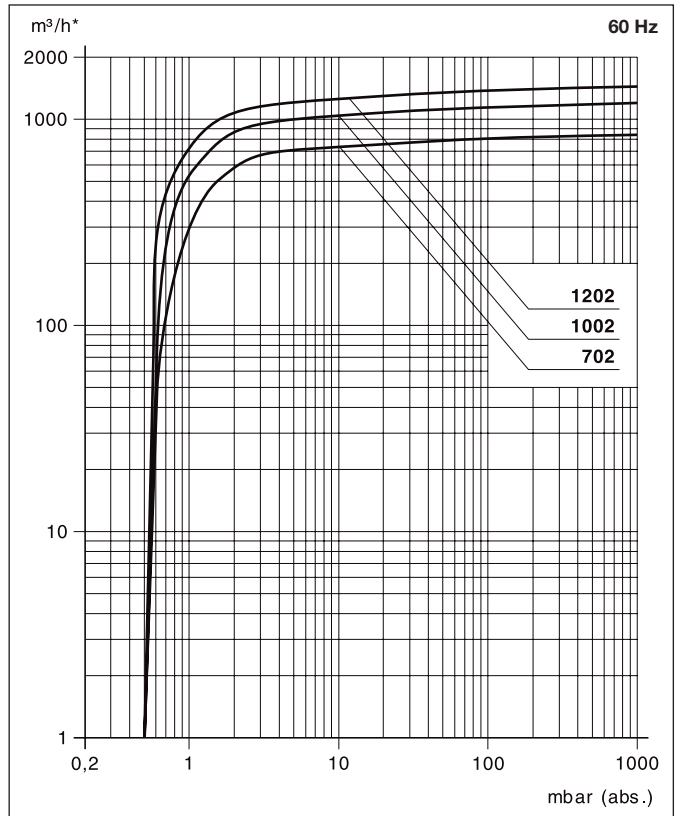
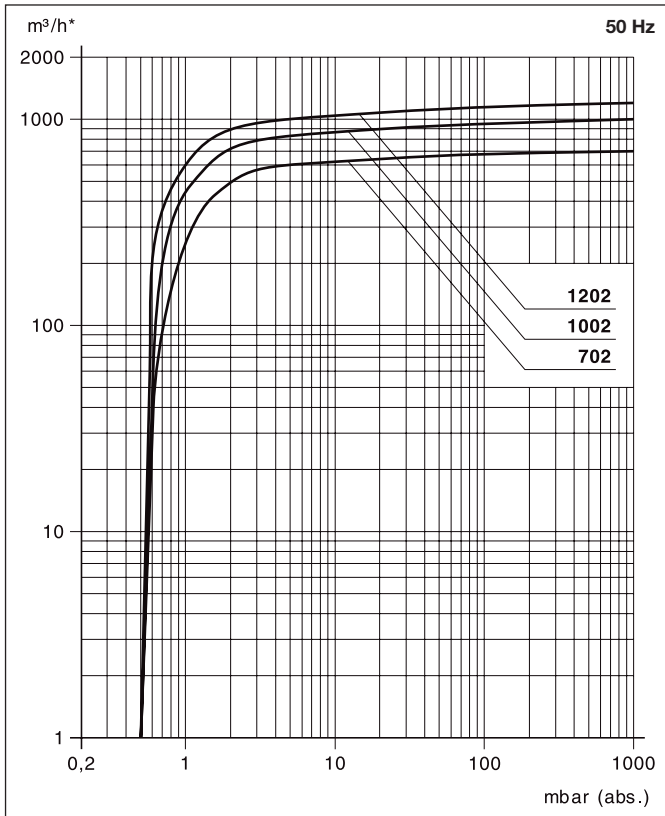

* bezogen auf den Zustand im Sauganschluss./ related to suction conditions at inlet connection./ relatif à l'état régnant à l'aspiration./ riferito alle condizioni in aspirazione.

Kennlinien und Tabellenangaben sind ermittelt nach PNEUROP und beziehen sich auf betriebswarme Vakuumpumpen./ Curves and tables calculated according to PNEUROP standards and refer to vacuum pump at normal operating temperature./ Les courbes et tableaux sont établies selon la norme PNEUROP, pompe à température de fonctionnement./ Le curve caratteristiche ed i dati riportati nelle tabelle rispondono alle norme PNEUROP e si riferiscono alle pompe per vuoto con funzionamento a regime.

Technische Änderungen vorbehalten! / We reserve the right to alter technical information! / Sous réserve de modification technique! / Salvo modifiche tecniche!

Die Abmessungen a und ø w sowie die Stromaufnahme können je nach Motorfabrikat von den hier aufgeführten Angaben abweichen./ The dimensions a and ø w and/or the current drawn can differ when compared with the data list, depending on the motor type./ Les dimensions a et ø w ainsi que l'ampérage peuvent différer des données indiquées ci-dessus, selon le fabricant du moteur./ Le dimensioni a e ø w come la corrente nominale possono scostarsi leggermente dai dati qui riportati a seconda del costruttore del motore.



Vakuumpumpen

Vacuum pumps

Pompes à vide

Pompe per vuoto

V-VWZ (13)

V-VWZ 702 (13)

V-VWZ 1002 (13)

V-VWZ 1202 (13)

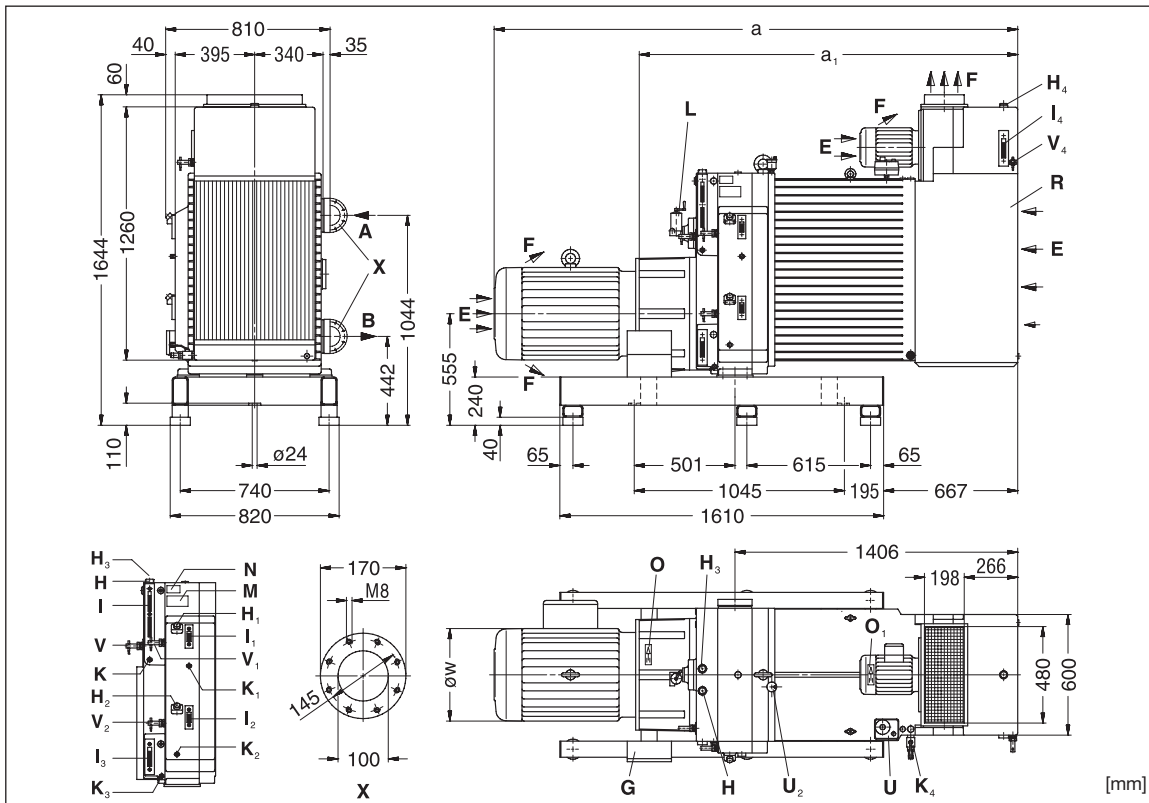

A	Vakuu-Anschluss	Vacuum connection	Raccord du vide	Attacco vuoto
B	Abluft-Austritt	Exhaust	Refolement	Scarico aria
E	Kühlluft-Eintritt	Cooling air entry	Entrée air refroidissement	Entrata aria di raffreddamen.
F	Kühlluft-Austritt	Cooling air exit	Sortie air refroidissement	Uscita aria di raffreddamento
G	Klemmenkasten	Terminal box	Boîte à bornes	Morsetteria
H	Öleinfüllstelle Frischöl	Fresh oil filling point	Point de rempliss. d'huile neuve	Punto di riempim. olio fresco
H ₁	Öleinfüllstelle Lager ND-Stufe	Oil filler bearing LP-stage	Rempliss. d'huile roulem. E.P.	Foro riempim. olio cuscin. ND
H ₂	Öleinfüllstelle Lager HD-Stufe	Oil filler bearing HP-stage	Rempliss. d'huile roulem. E.S.	Foro riempim. olio cuscin. HD
H ₃	Öleinfüllstelle Getriebe	Oil filler gear box	Rempliss. d'huile engrenage	Foro riempim. olio ingranaggi
H ₄	Kühlwassereinfüllstelle und Sicherheitsventil	Cooling water filler and safety valve	Remplissage d'eau refroidiss. et clapet de sécurité	Riempimento acqua raffredd. e valvola di sicurezza
I	Ölkontrolle Frischöl	Oil check fresh oil	Contrôle d'huile neuve	Spia controllo olio fresco
I ₁	Ölkontrolle Lager ND-Stufe	Oil check bearing LP-stage	Contrôle d'huile roulem. E.P.	Spia controllo olio cuscin. ND
I ₂	Ölkontrolle Lager HD-Stufe	Oil check bearing HP-stage	Contrôle d'huile roulem. E.S.	Spia controllo olio cuscin. HD
I ₃	Ölkontrolle Getriebe	Oil check gear box	Contrôle d'huile engrenage	Spia controllo olio ingranaggi
I ₄	Kühlwasserkontrolle	Cooling water check	Contrôle eau refroidissement	Controllo acqua raffreddamento
K	Ölablassstelle Frischöl	Fresh oil drain point	Point de vidange d'huile neuve	Punto scarico olio fresco
K ₁	Ölablassstelle Lager ND-Stufe	Oil drain bearing LP-stage	Vidange d'huile roulem. E.P.	Scarico olio cuscinetti ND
K ₂	Ölablassstelle Lager HD-Stufe	Oil drain bearing HP-stage	Vidange d'huile roulem. E.S.	Scarico olio cuscinetti HD
K ₃	Ölablassstelle Getriebe	Oil drain gear	Vidange d'huile engrenage	Scarico olio ingranaggi
K ₄	Kühlwasserablass	Cooling water drain	Purge d'eau refroidissement	Scarico acqua di raffreddamento
L	Ölschmierpumpe	Oil metering pump	Pompe de lubrification	Pompa dell'olio
M	Ölempfehlungsschild	Oil type plate	Plaquette recomm. d'huiles	Targhetta oli consigliati
N	Datenschild	Data plate	Etiquette caractéristique	Targhetta dati
O, O ₁	Drehrichtungsschild	Direction of rotation	Flèche sens rotation	Targhetta senso rotazione
R	Wasserkühler	Water cooler	Radiateur d'eau	Refrigeratore acqua
U	Sicherheits- und Betriebstemperaturthermostat	Safety and operating temperature thermostat	Thermostat de sécurité et de température de fonctionnement	Termostato di sicurezza e di temperatura di funzionamento
U ₂	Kühlwasserentlüftung	Cooling water vent	Aération eau refroidissement	Spurgo aria
V	Niveauwächter-Frischöl	Level switch fresh oil	Contacteur niveau huile neuve	Sonda di livello olio fresco
X	Flansch DN 100 DIN 28404	Flange DN 100 DIN 28404	Bride DN 100 DIN 28404	Flangia DN 100 DIN 28404
V ₁	Zubehör	Optional extras	Accessoires	Accessori
V ₂	Niveauwächter Lager ND-Stufe	Level switch bearing LP-stage	Cont. niv. d'huile roulem. E.P.	Sonda di livello cuscinetti ND
V ₄	Niveauwächter Lager HD-Stufe	Level switch bearing HP-stage	Cont. niv. d'huile roulem. E.S.	Sonda di livello cuscinetti HD
	Niveauwächter-Kühlwasser	Level switch cooling water	Contacteur niveau eau refroidis.	Sonda di livello acqua raffredd.

V-VWZ (13)	702	1002	1202			
[mm]	a / a ₁	2480 / 1852 (18,5 - 22 kW)	2585 / 1882 (30 kW)	2672 / 1882 (37 kW)		
	øw	360	360	431	431	489

D 137

2.2.98

**Gardner Denver
Schopfheim GmbH**

Postfach 1260

79642 SCHOPFHEIM
GERMANY

Fon +49 7622 / 392-0

Fax +49 7622 / 392-300

e-mail: er.de@
gardnerdenver.com

www.gd-elmorietschle.com

V-VWZ (13)		702		1002		1202	
m³/h	50 Hz	700		1000		1200	
	60 Hz	840		1200		1440	
mbar (abs.)•		0,5					
3~	50 Hz	400/690V ± 10%					
	60 Hz	380/660V					
kW	50 Hz	18,5	22,0	22,0	30,0	30,0	37,0
	60 Hz	22,2	26,4	26,4	36,0	36,0	44,4
A	50 Hz	36/20,8	43/24,8	43/24,8	58/33,5	58/33,5	73/42
	60 Hz	#	#	#	#	#	#
min⁻¹	50 Hz	950					
	60 Hz	1140					
dB(A)	50 Hz	80		81		83	
	60 Hz	81		82		84	
kg		1750	1810	2379	2500	2610	2650
l (H)		3 / 21					
l/h (H)		0,342 / 0,410		0,760 / 0,912		0,949 / 1,138	
l (H₁) / l (H₂) / l (H₃)				3,5 / 4,5 / 7,0			
l (Y)		360		370		370	

m³/h	Saugvermögen	Capacity	Débit	Portata
mbar (abs.)•	Enddruck	Ultimate vacuum	Pression limite	Pressione finale
mbar (abs.)	Ansaugdruck	Suction pressure	Pression d'aspiration	Pressione di aspirazione
3~	Motorausführung	Motor version	Exécution moteur	Esecuzione motore
kW	Motorleistung	Motor rating	Puissance moteur	Potenza motore
A	Stromaufnahme	Current drawn	Intensité absorbée	Corrente nominale
min⁻¹	Drehzahl	Speed	Vitesse rotation	Numero giri
dB(A) → DIN 45635	Mittlerer Schalldruckpegel	Average noise level	Niveau sonore moyen	Rumorosità media
kg	Max. Gewicht	Maximum weight	Poids maxi.	Peso massimo
l (H)	Frischölvorrat min./max.	Fresh oil capacity min./max.	Réserve d'huile min./max.	Scorta olio fresco min./mass.
l/h (H)	Frischölverbrauch	Fresh oil consumption	Consommation d'huile neuve	Consumo d'olio fresco
l (H₁)	Öleinfüllmenge Lager ND-Stufe	Oil capacity LP-stage	Charge d'huile roulements E.P.	Quantità olio cuscinetti ND
l (H₂)	Öleinfüllmenge Lager HD-Stufe	Oil capacity HP-stage	Charge d'huile roulements E.S.	Quantità olio cuscinetti HD
l (H₃)	Öleinfüllmenge Getriebe	Oil capacity gear	Charge d'huile engrenage	Quantità olio ingrannaggi
l (Y)	Kühlwassermenge (50% Glysantin)	Cooling water capacity (50% glysantin)	Charge eau refroidissement (eau et additif)	Quantità acqua raffreddamento (50% glysantin)

Zubehör Flüssigkeitsabscheider Rückschlagventil Stern-Dreieck-Schaltgerät Vakuum-Schalter / Vakuummeter Vakuumdichter Staubabscheider 2/2-Wege-Magnetventil Ölnebelabscheider Spülmittelreinrichtung	Optional extras Liquid separator Non return valve Star-Delta starter Vacuum switch / Vacuum gauge Dust separator vacuum tight 2/2-way solenoid valve Oil mist separator Flushing unit	Accessoires Séparateur de liquide Clapet anti-retour Démarreur étoile-triangle Commutateur vide / Vacuomètre Filtre séparateur étanche Électrovanne 2/2 voies Séparateur brouillard d'huile Dispositif produit rinçage	Accessori Separatore di liquido Valvola di non ritorno Avviamento stella-triangolo Interruttore a vuoto / Manovuotometro Separatore polveri ermetico Elettrovalvola a 2/2 vie Separatore fumi olio Dispositivo fluido di solvente
--	---	--	---

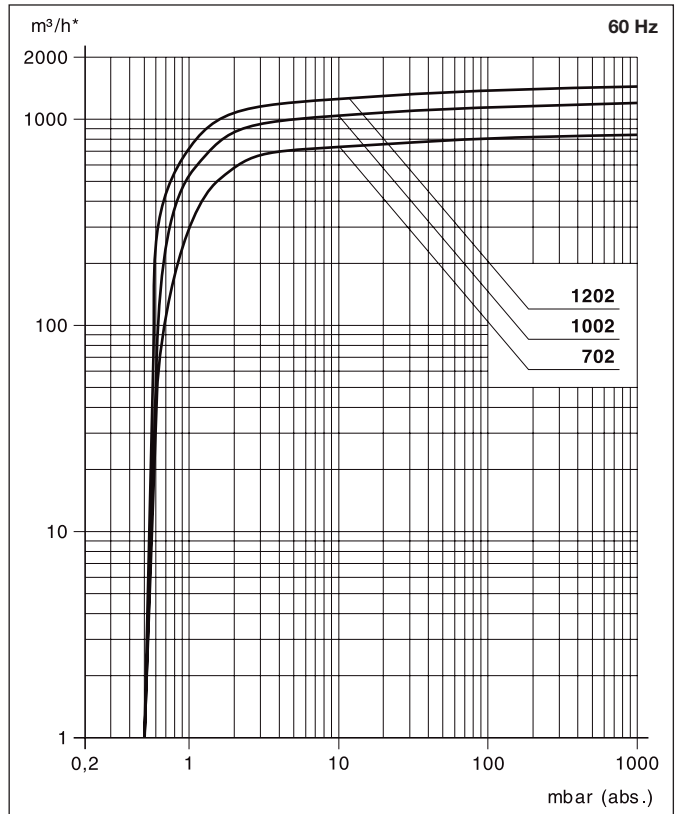
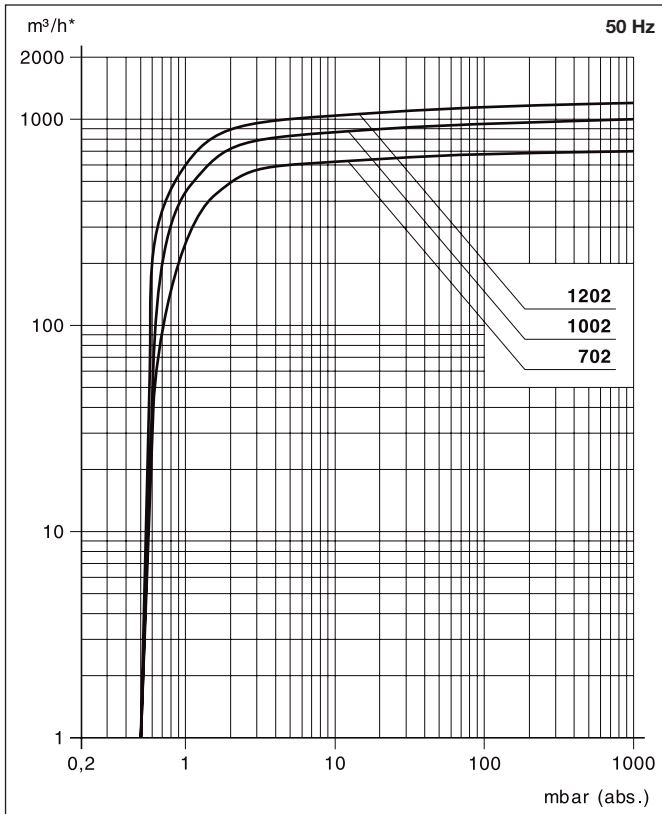

* bezogen auf den Zustand im Sauganschluss./ related to suction conditions at inlet connection./ relatif à l'état régnant à l'aspiration./ riferito alle condizioni in aspirazione.
 Kennlinien und Tabellenangaben sind ermittelt nach PNEUROP und beziehen sich auf betriebswarme Vakuumpumpen./ Curves and tables calculated according to PNEUROP standards and refer to vacuum pump at normal operating temperature./ Les courbes et tableaux sont établies selon la norme PNEUROP, pompe à température de fonctionnement./ Le curve caratteristiche ed i dati riportati nelle tabelle rispondono alle norme PNEUROP e si riferiscono alle pompe per vuoto con funzionamento a regime.
 Technische Änderungen vorbehalten! / We reserve the right to alter technical information! / Sous réserve de modification technique! / Salvo modifiche tecniche!
 Die Abmessungen a und ϕ w sowie die Stromaufnahme können je nach Motorfabrikat von den hier aufgeführten Angaben abweichen./ The dimensions a and ϕ w and/or the current drawn can differ when compared with the data list, depending on the motor type./ Les dimensions a et ϕ w ainsi que l'ampérage peuvent différer des données indiquées ci-dessus, selon le fabricant du moteur./ Le dimensioni a e ϕ w come la corrente nominale possono scostarsi leggermente dai dati qui riportati a seconda del costruttore del motore.