

GRADALL®

XL 7320 V

MINE SCALER MACHINE



SPECIFICATIONS

Engine

- Volvo TAD572 VE, Tier 4f, MSHA Certified 4 cycle, inline 4 cylinder, liquid cooled, electronic controlled
- Vertical canister style lube and main fuel filters and fuel/water separation with manual feed pump attached to engine
- Water in fuel indicator and alarm

Gross Rating: 215 hp @ 2200 rpm (160kW)
671 ft lb torque @ 1100-1500 rpm (910Nm)

Net Rating: 195 hp @ 2200 rpm (145kW)

- Variable viscous fan clutch system
- Vertical stacked hydraulic oil cooler, charge air cooler and radiator
- Block heater

Maximum slope: 30°

- 24 volt starter
- 100 amp alternator
- Two SAE #C31-S 1000 CCA batteries
- Two-stage air cleaner with high-efficiency pre-cleaner, vacuumator valve and remote service indicator

Fuel tank capacity: 90 gallon (341 L)

Operator Cab

- All-weather cab
- Tinted safety glass windows
- Acoustical lining
- Four-way adjustable seat
- AM/FM radio
- Filtered fresh air heater
- Defroster
- Air conditioner
- Front window slides to overhead position
- Rearview mirror on left side
- Seat belt
- Swing lights
- Cab tilt angle is infinitely adjustable from level to 23° upward
- Pressure cab with Heppa Filter
- Cab cage with protective rock guard
- Camera system with three external cameras

Controls

- Two electronic joysticks (hoist and bucket, telescope and swing)
- One rocker switch (tilt) control
- Joysticks mounted on arm pods
- Quick change joystick pattern switch located on instrument panel
- Self-centering joysticks; when controls are released, power for movement disengages and swing and tilt brake set automatically
- Tilting/telescoping steering column
- Hydraulic foot pedal controls braking functions
- Travel speed is regulated with an electronic foot pedal control
- Switch on the FWD/REV selector provides 1st/2nd gear selection
- Independent rocker switches control park brake and travel alarm mode

Engine Controls and Instrumentation

- Key operated ignition/starter switch, throttle, and main battery disconnect switch
- Air cleaner condition indicator
- Electronic monitor indicates fuel level, low battery charge, lube oil pressure, high coolant temperature, engine rpm, and engine hours with shutdown protocol
- Fuel saving auto idle feature sends engine rpm to idle when control circuits are in neutral for seven seconds

Boom

- Two piece triangular telescoping boom
- Adjustable boom rollers with eccentric shafts
- 270° boom tilt
- 74° boom pivot angle
- Auxiliary hydraulics

Hydraulic System

Pumps

- One load-sensing, axial piston pump; oil flow 0-110 GPM (0-416 L/min)
- Tandem gear pump (steering, brake/pilot) 10 GPM (38 L/min), 6 GPM (23 L/min)

System monitor

- Electronic monitor in cab indicates
 - Low hydraulic fluid level
 - High hydraulic fluid temperature
 - System working pressure
 - System pilot pressure

SYSTEM SPECIFICATIONS

Six cylinders

- One tool: 5.0" ID, 3.0" rod, (127 mm x 76 mm) 25.9" (658 mm) stroke
- Two hoist cylinders: 4.25" ID, 3.0" rod, (108 mm x 76 mm) 53.43" (1357 mm) stroke
- One telescope: 4.5" ID, 3.25" rod, (114 mm x 83 mm) 13'6" (3.94 m) stroke
- Two single-acting axle oscillation cylinders: 4.528" ID, 4.528" rod (115 mm x 115 mm), 6.25" (159 mm) stroke

Three hydraulic motors

- Swing, 68 hp (51 kW)
- Tilt, 28 hp (21 kW)
- Propel, 113 hp (84 kW)

Operating pressures:

- Hoist.....4,900 psi (331 BAR)
- Tilt.....2,400 psi (165 BAR)
- Swing.....4,500 psi (310 BAR)
- Tool.....4,900 psi (331 BAR)
- Telescope.....3,300 psi (228 BAR)
- Propel.....4,900 psi (331 BAR)
- Pilot System.....550 psi (38 BAR)
- Braking & Steering.....2,400 psi (165 BAR)

Oil Capacity

- Reservoir system 61 gallon (231 L)
- Pressurized reservoir with visual oil level gauges

Filtration System

- 10 micron return filter
- 10 micron pilot filter
- Fin and tube-type oil cooler with thermal by-pass and relief valves
- Pressure-compensated, load-sensing valves with circuit reliefs in all circuits

Undercarriage

- Full-time 4 x 4 drive with 2-speed Powershift transmission
- Rigid mount rear axle
- Oscillating front steer axle with automatic lock-out cylinders
- Four-wheel enclosed sealed wet-disc brakes
- Access ladders on both sides and both ends of machine
- Locking toolboxes on each side

Maximum Travel Speed: 11 mph (17.7 kph)

Maximum Gradeability: 47%

Min. Turning Radius (curb-curb): 38 ft (11.6 m)

Tires: 16.00 x 25 (28 ply)

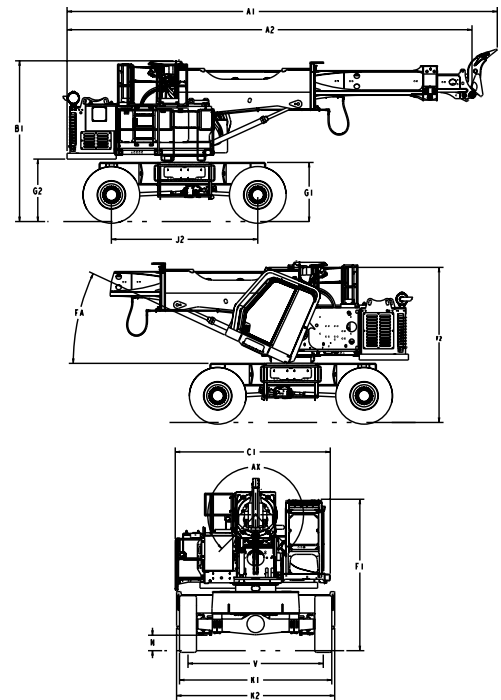
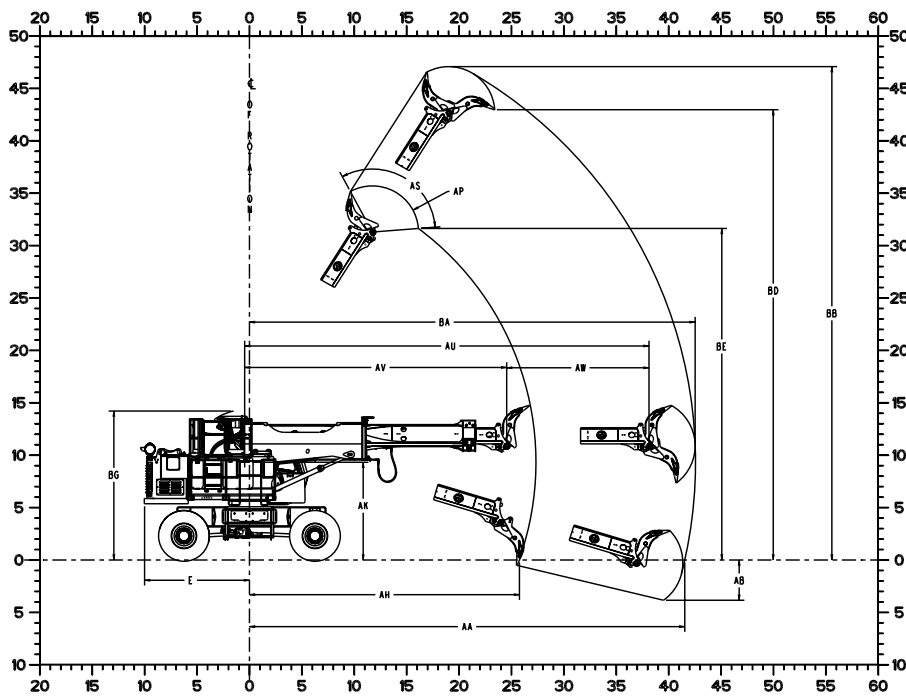

Dimensions

	47' Boom	52' Boom		47' Boom	52' Boom		
A1	36' 9" (11.2)	43' 0" (13.1)	Overall length (boom level) with scaling hook	AA	41' 6" (12.7)	47' 10" (14.6)	Maximum radius at groundline
A2	34' 7" (10.5)	40' 10" (12.4)	Overall length (boom level) without scaling hook	AB	3' 10" (1.2)	6' 2" (1.9)	Maximum depth
B1	13' 8" (4.2)	13' 8" (4.2)	Overall height (boom level)	AH	26' 3" (8.0)	32' 2" (9.8)	Minimum radius at groundline
C1	13' 4" (4.1)	13' 4" (4.1)	Width of upperstructure	AK	9' 4" (2.8)	9' 4" (2.8)	Boom pivot to groundline
E	10' 0" (3.0)	10' 0" (3.0)	Swing clearance, rear of upperstructure	AP	4' 5" (1.3)	4' 5" (1.3)	Scaling hook tooth radius
F1	13' 2" (4.0)	13' 2" (4.0)	Top of cab guard to groundline (cab level)	AS	114°	114°	Attachment pivot angle
F2	13' 6" (4.1)	13' 6" (4.1)	Top of cab guard to groundline (cab at full tilt)	AU	38' 7" (11.8)	44' 9" (13.6)	Maximum telescoping boom length (boom pivot to attachment pivot)
FA	25°	25°	Cab tilt	AV	25' 0" (7.6)	31' 3" (9.5)	Minimum telescoping boom length (boom pivot to attachment pivot)
G1	5' 2" (1.6)	5' 2" (1.6)	Clearance, upperstructure to groundline	AW	13' 6" (4.1)	13' 6" (4.1)	Telescoping boom travel
G2	5' 4" (1.6)	5' 4" (1.6)	Clearance, counterweight to groundline	AX	270°	270°	Standard boom tilt angle
J2	12' 6" (3.8)	12' 6" (3.8)	Nominal distance between centerlines of front and rear axles	BA	42' 6" (13.0)	48' 9" (14.9)	Maximum radius of working equipment
K1	13' 1" (4.0)	13' 1" (4.0)	Width of chassis, tool boxes in inner position	BB	47' 1" (14.3)	52' 3" (15.9)	Maximum height of working equipment
K2	13' 6" (4.1)	13' 6" (4.1)	Width of chassis, tool boxes in outer position	BD	43' 0" (13.1)	48' 2" (14.7)	Minimum clearance of scaling hook, with attachment pivot at maximum height
N	1' 4" (0.4)	1' 4" (0.4)	Ground clearance	BE	31' 8" (9.6)	36' 10" (11.2)	Minimum clearance of scaling hook at maximum boom height
V	11' 7" (3.5)	11' 7" (3.5)	Wheel centerline to centerline	BG	14' 3" (4.3)	14' 3" (4.3)	Maximum height of working equipment with boom below groundline

Specifications subject to change without notice.
Metric units are meters (m) unless noted.
Machines shown may have optional equipment.

It is Gradall Policy to continually improve its products. Therefore designs, materials and specifications are subject to change without notice and without incurring any liability on units already sold. Units shown may have optional equipment.

GRADALL®

406 Mill Ave. SW, New Philadelphia, Ohio 44663
Phone: 800-445-4752 Fax: 330-339-8468
www.Gradall.com

ALAMO GROUP GRADALL INDUSTRIES, INC.
World Agency Work

Form No. 11834 12/19
Printed in USA

Swing

- Priority swing circuit with axial piston motor
- Planetary transmission

Swing Brake

- Automatic spring-set/hydraulic release wet-disc parking brake
- Dynamic braking is provided by the hydraulic system

Function Forces

Rated Boom In: 23,210 lbs (103 kN)

Rated Boom Out: 27,357 lbs (122 kN)

Rated Ripper Tooth Force: 19,888 lbs (89 kN)

Boom Rotating Torque: 18,375 ft lb (24913 Nm)

Weight

- Approximate working weight:
- 77,500 lb (35,153 kg)