

BLOCCO MULTIPLO ATTACCHI LATERALI
COLLEGAMENTO PARALLELO
MONOBLOCK WITH ON SIDE PORTS
PARALLEL CONNECTION
CETOP 5 - NG 10

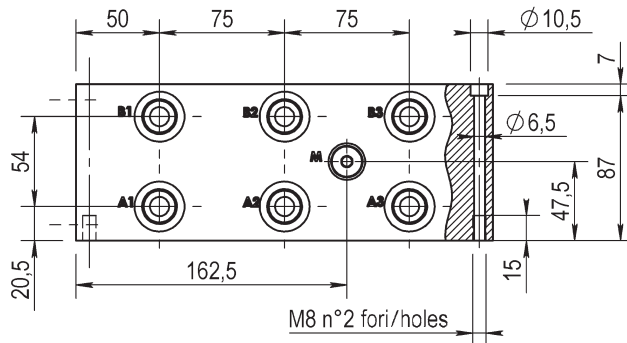

Postaz. N° N° Stations	L1	L
1	84	100
2	159	175
3	234	250
4	309	325
5	384	400
6	459	475
7	534	550
8	609	625

M1 = G1/4

Presca manometro / Testing point

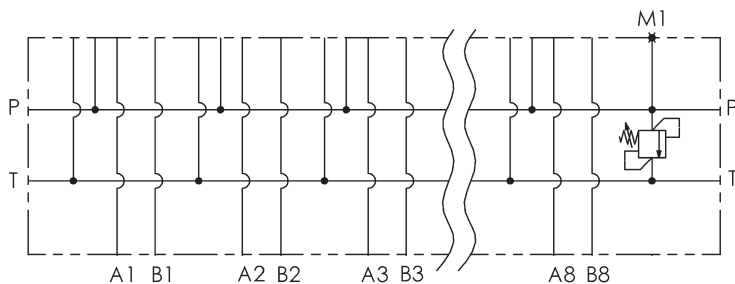
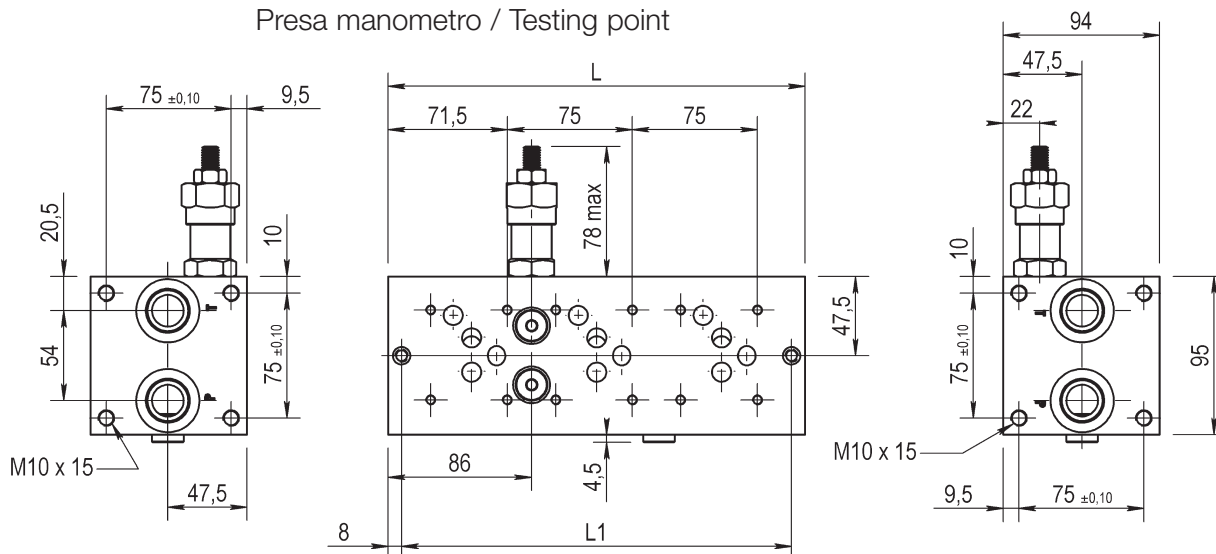

Versione standard in alluminio
Standard type with aluminium

Pressione massima di lavoro = 300 bar
Max working pressure = 300 bar

Caratteristiche valvola di massima
vedere a pagina 25
For further information regarding relief
valve please see page 25

Esempio codice di ordinazione - Ordering example

BMA 10 P 3 L # # - # — 10 = (35-100 bar)
20 = (80-250 bar)

Monoblocco alluminio
Aluminium monoblock

CETOP 5 - NG 10

Collegamento in parallelo
Parallel connection

Attacchi - Ports (P - T = G3/4 A - B = G1/2)

z = predisposta per valvole
machined for relief valve
x = con valvola di max
with built-in relief valve

1 - 2 - 3 - 4 - 5 - 6 - 7 - 8
Numero postazioni - Stations number

Configurazione con attacchi laterali
On side ports

VS-30

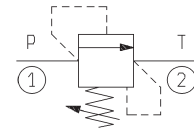
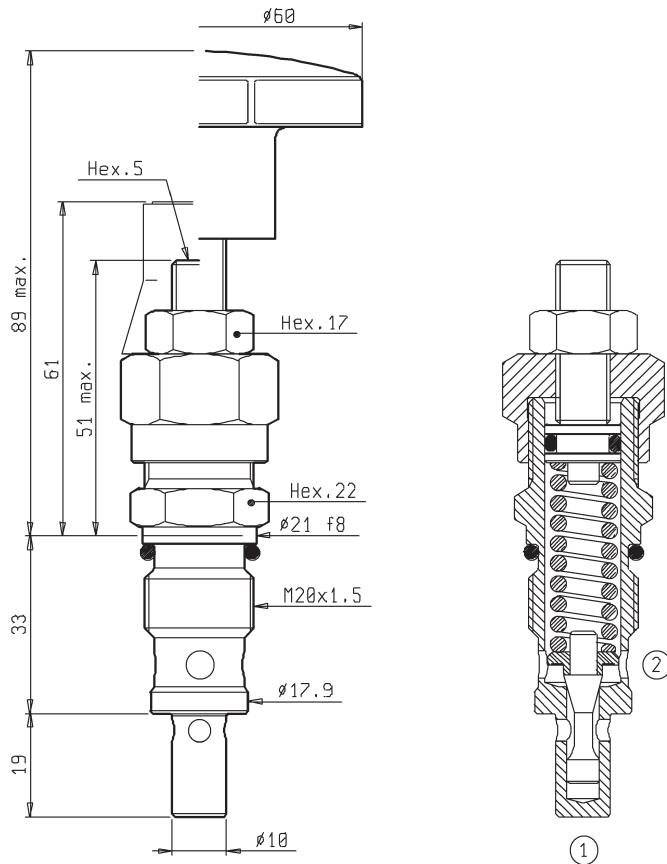

DATI TECNICI / TECHNICAL DATA

Coppie di serraggio Installation torque	46-51 Nm
Pressione di lavoro max Max working pressure	350 bar
Portata max Max flow	30 l/min
Peso Weight	0.17 kg

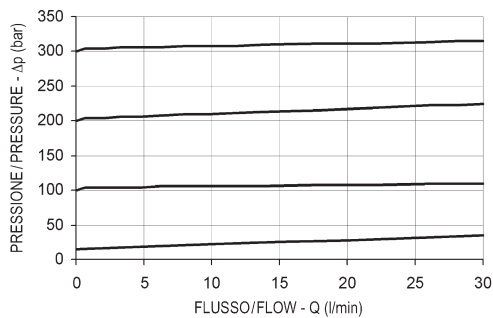

REGOLAZIONI / ADJUSTMENTS

Vite esterna
Socket screw



Volantino
Handknob



Esempio codice di ordinazione - Ordering example

R02010300

Tarature / Setting

05 = (5-50 bar)

20 = (30-210 bar)

35 = (100-350 bar)

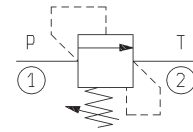
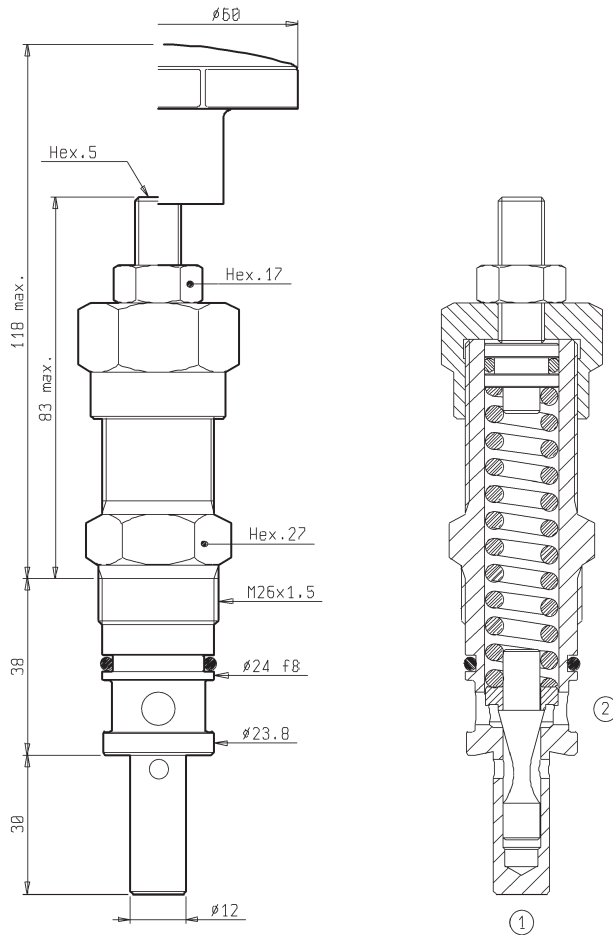

DATI TECNICI / TECHNICAL DATA

Coppie di serraggio Installation torque	83-92 Nm
Pressione di lavoro max Max working pressure	250 bar
Portata max Max flow	80 l/min
Peso Weight	0.35 kg

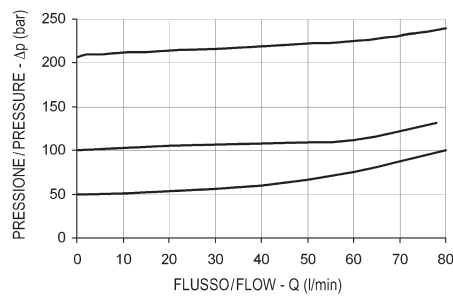

REGOLAZIONI / ADJUSTMENTS

Vite esterna
Socket screw



Volantino
Handknob



Esempio codice di ordinazione - Ordering example

R02010301 ##

Tarature / Setting
10 = (35-100 bar)
20 = (80-250 bar)