

assembly manual

Op. Visio L1H

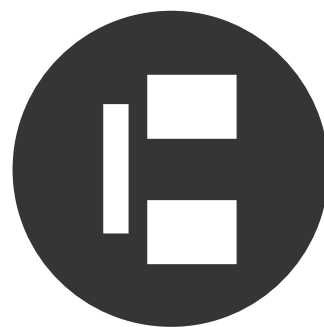

manussa
Automatic Doors

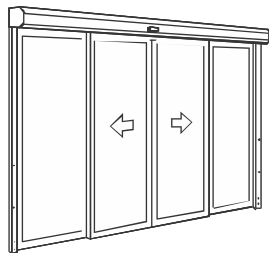

Visio Lateral 1 Leaf Operator

Assembly f1

Unpacking the material

1.1 DRIVE UNIT BOX

i

In this box we find all the components required for the assembly of the Visio operator drive unit.

opc These components are optional. They will be present in the box if they form part of the order.

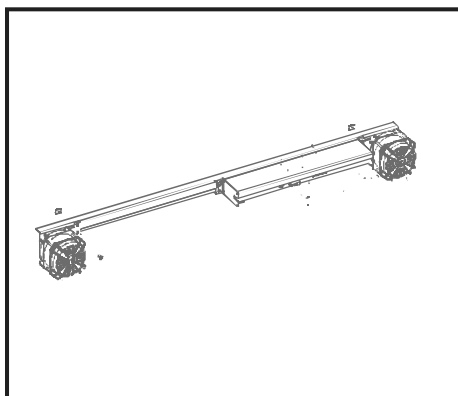
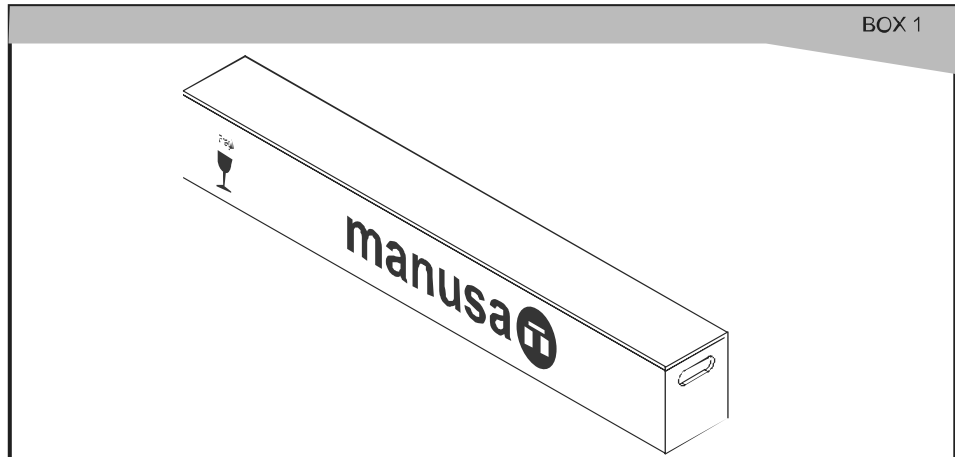

Ref	Description	Location
GIE01	Visio drive unit	Box 1

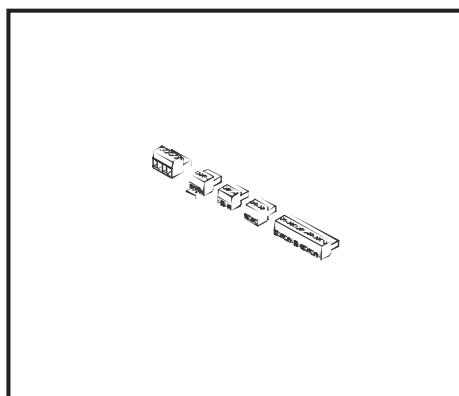

Ref	Description	Location
KCGI01	Visio unit connector pack	Box 1

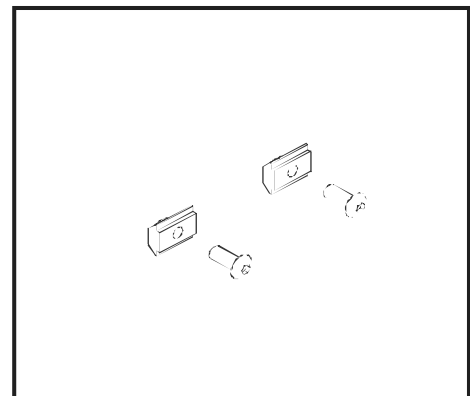

Ref	Description	Location
KTSGMI01	Pack drive unit sec. screws	Box 1

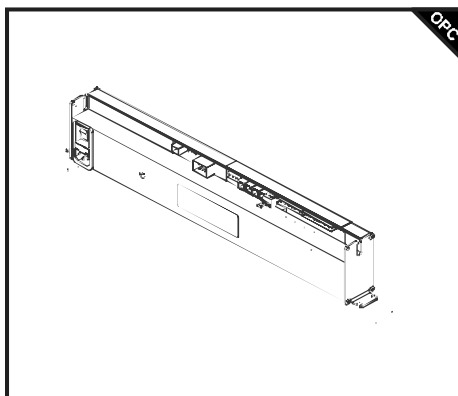

Ref	Description	Location
GIEL01	Pack drive unit sec. screws	Box 1

1.2 CHASSIS BOX

i
 In this box we find the sections and components which make up the Visio operator chassis.

OPC
 These components are optional. They will be present in the box if they form part of the order.

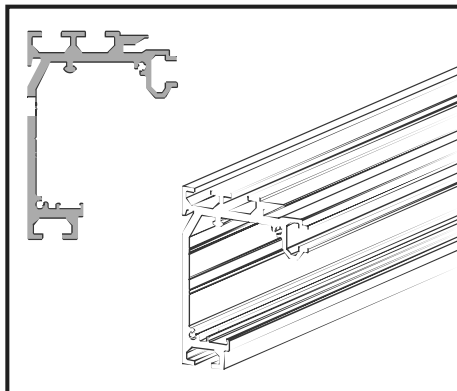
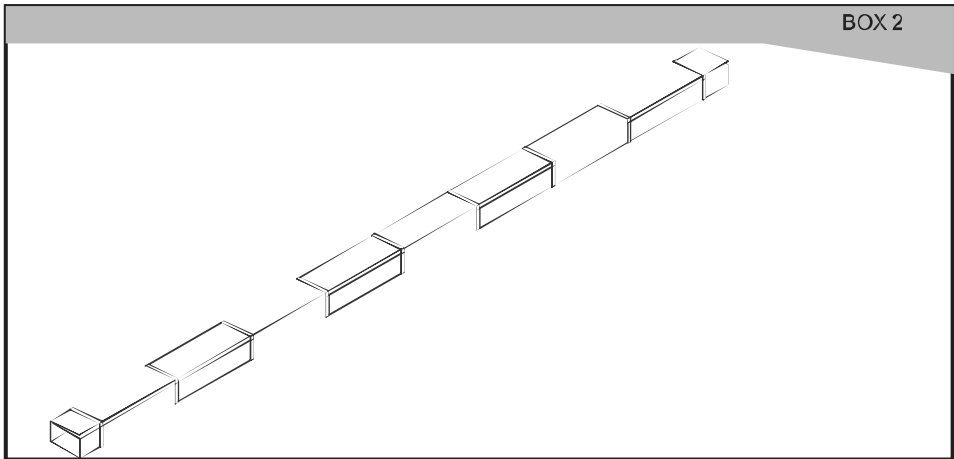

Ref	Description	Location
PACIPP	Visio Chassis al. B. main profile	Box 2

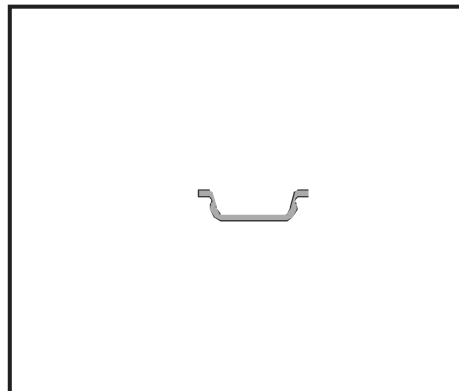

Ref	Description	Location
JUCIAR	Visio ch. join wheel-track ins.	Box 2

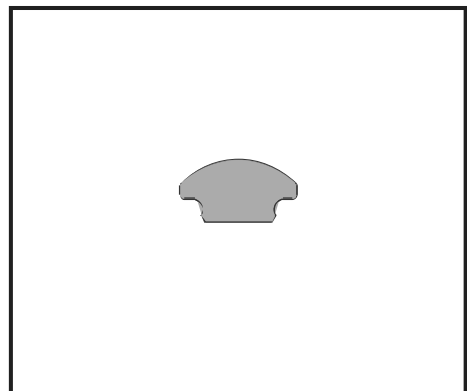

Ref	Description	Location
PACIPR	Visio chassis wheel-track	Box 2

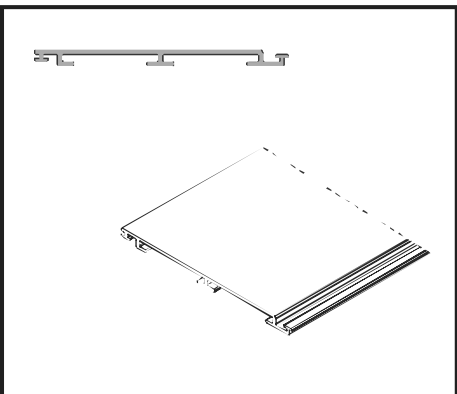

Ref	Description	Location
PACICH	Al.Beam.Visio Ch. Horiz. Cover	Box 2

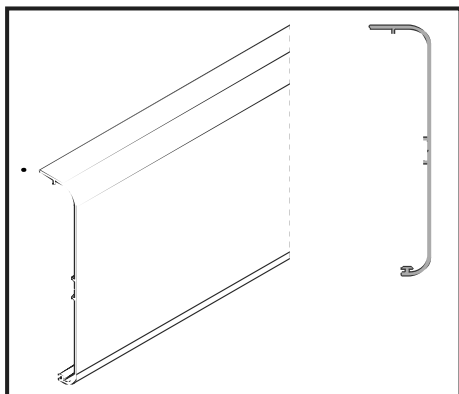

Ref	Description	Location
PACICF	Al.Beam.Visio Ch. Cover	Box 2

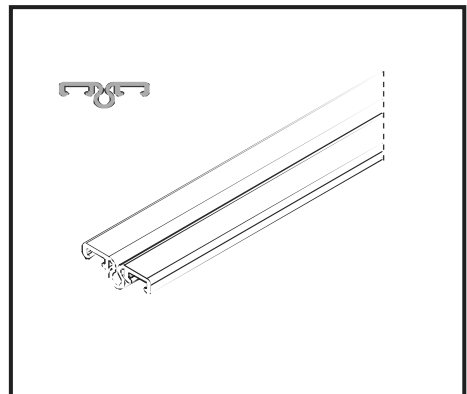

Ref	Description	Location
PPCIBC	PVC B. Visio Ch. Cov. hinge	Box 2

1.2 CHASSIS BOX

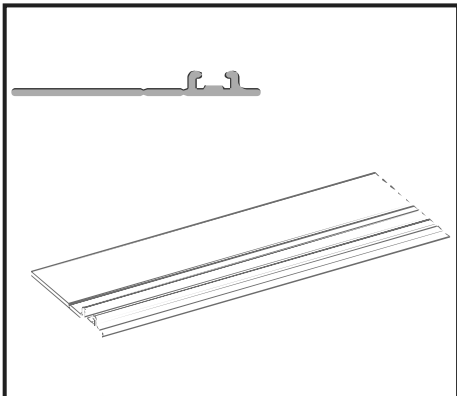

Ref	Description	Location
PCPIPF	PVC B. Visio Ch. woolpile holder	Box 2

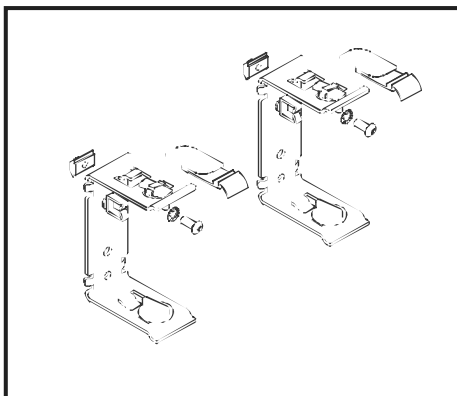

Ref	Description	Location
KSC12501	Pack Brack. for Cover 125	Box 2

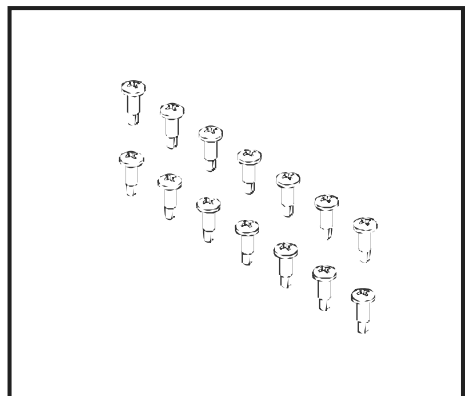

Ref	Description	Location
KCITA	Self-drill chassis nuts and bolts	Box 2

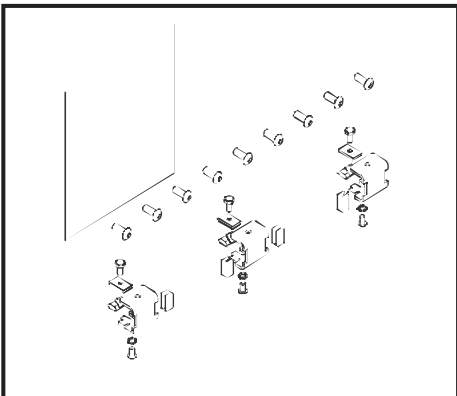

Ref	Description	Location
KCIP0101	Visio chassis main frame pack	Box 2

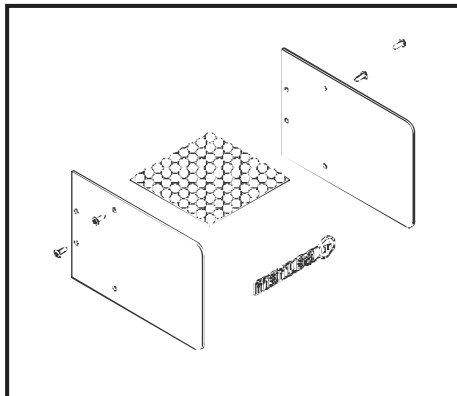

Ref	Description	Location
KTC12501	Pack cover end caps 125	Box 2

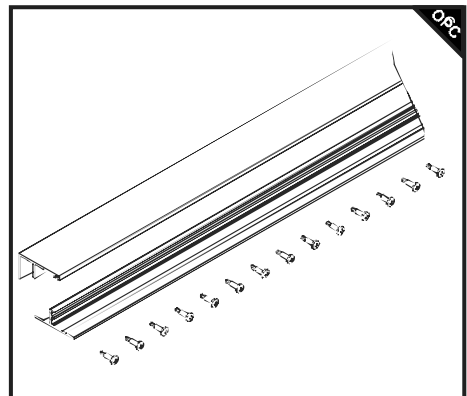

Ref	Description	Location
KCI125HF	Visio fixed leaf pack	Box 2

1.3 ACCESSORIES

 In this box we find all the accessories required for the assembly of the Visio operator.

opc These components are optional. They will be present in the box if they form part of the order.

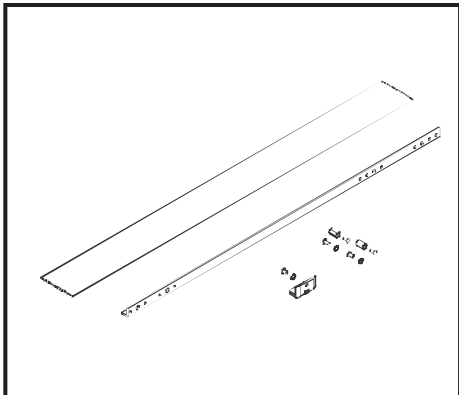
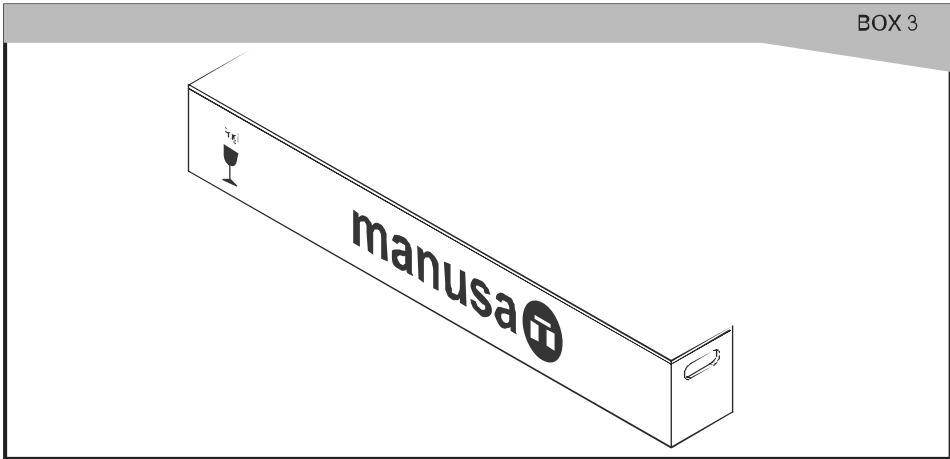

Ref	Description	Location
BRCI01	Visio dragging arm	Box 3

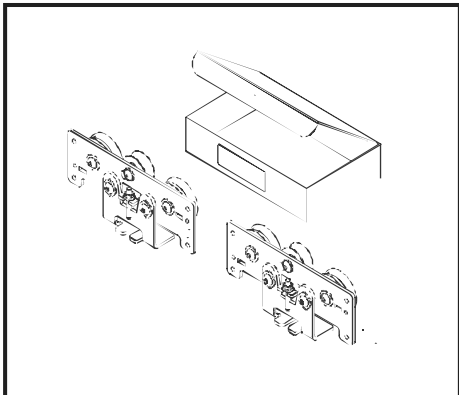

Ref	Description	Location
CACI01	Visio sliding leaf trolley set	Box 3

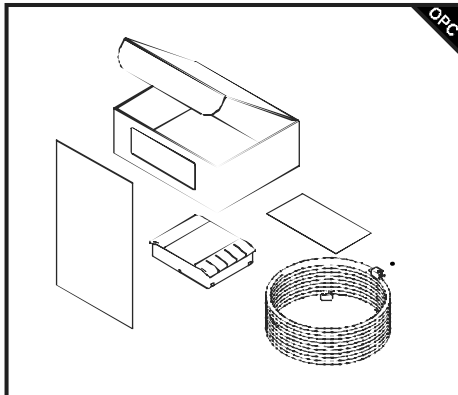

Ref	Description	Location
EMSL01	Smart Selector LCD	Box 3

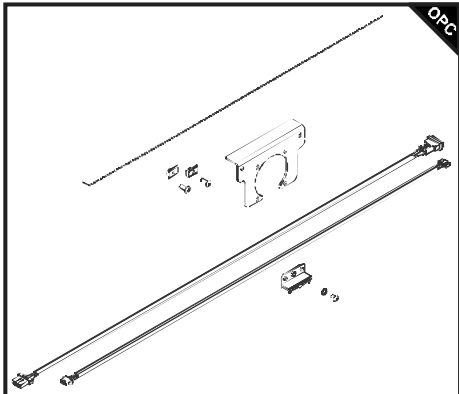

Ref	Description	Location
KEGI01	Visio Kit extension	Box 3



Visio Lateral 1 Leaf Operator

Assembly f2

Installation dimensions and checks

2.1 LEGEND AND FORMULAE

Abr	DESCRIPTION	FORMULA
AH	INSTALLATION OPENING WIDTH	
HL	DOOR CLEAR HEIGHT	
PL	DOOR CLEAR WIDTH	$PL = (AH - Dt) / 2$
AT	OVERALL OPERATOR WIDTH	$AT = PL \times 2 + Dt$
HM	SLIDING LEAF HEIGHT	$HM = HL$
HF	FIXED LEAF HEIGHT	$HF = HL$
AM	SLIDING LEAF WIDTH	$AM = PL + Sp$
AF	FIXED LEAF WIDTH	$AF = AH - PL$
HV	BEAM HEIGHT	$HV = HL + 28$
HT	OVERALL DOOR HEIGHT	$HT = HL + 125$
HR	MINIMUM CEILING HEIGHT	$HR = HT + (5 \text{ min})$
Dt	TOTAL DOOR DEDUCTION	$Dt = Dop + S1 + S2$
S2	MINIMUM SAFETY DISTANCE HEAD AND BODY	AS PER DET 2.4.1
S1	MINIMUM SAFETY DISTANCE HANDS AND FINGERS	AS PER DET 2.4.2
Sp*	OVERLAP FIXED LEAF / SLIDING LEAF	DEP. ON WOODWORK
Dop *	OPERATOR DEDUCTION	DEP. ON WOODWORK



Dop * Operator deduction depending on woodwork:

Woodwork 20,30,35,40	= 50
Woodwork 44	= 100
Woodwork SOS 44	= 150



Sp* Overlap between door leaves depending on woodwork:

Woodwork 20,30,35,40	= 40
Woodwork 44	= 95

2.2 INSTALLATION DIMENSIONS

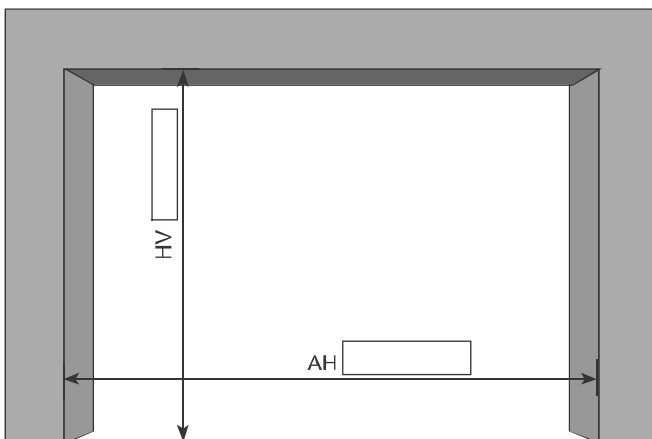

Fig. 2.1



Check that the dimensions correspond to the order. (See delivery note.) AT x HL ; PL

Fig. 2.1

AH, Opening Width =
HV, Beam Height =

2.3 DOOR DIMENSIONS

2.3.1 DOOR WIDTH

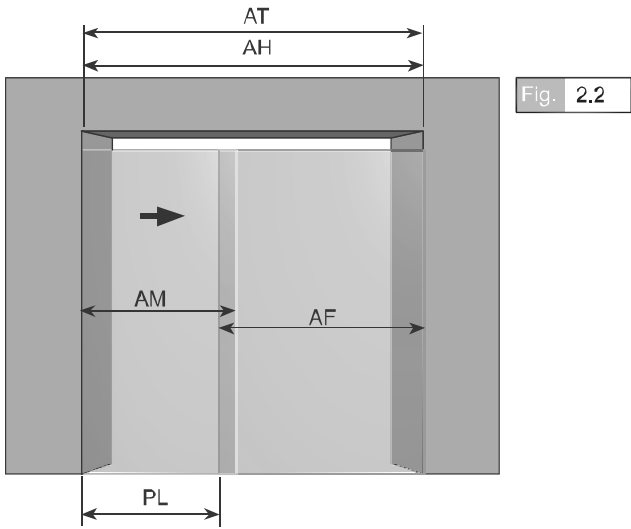

i

AH	Opening width
PL = (AH-Dt)/2	Clear width
AT = PL/2 + Dt	Overall operator width
AM = PL + Sp	Sliding leaf width
AF = AH-PL	Fixed leaf width

Fig. 2.2

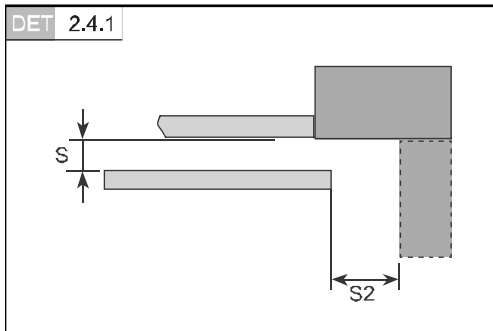
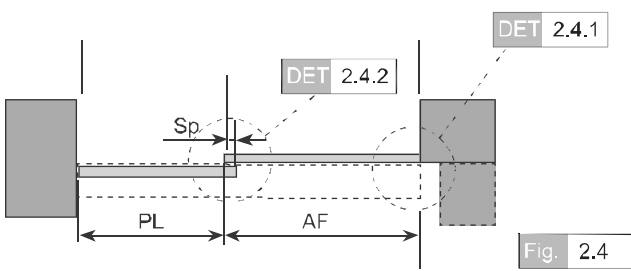
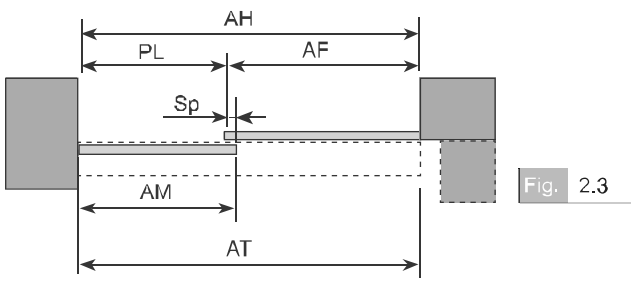

i

S2* Safety distance depends on S as follows:

If S < 250 S2 = 200 mm
 If S ≥ 250 S2 = 500 mm

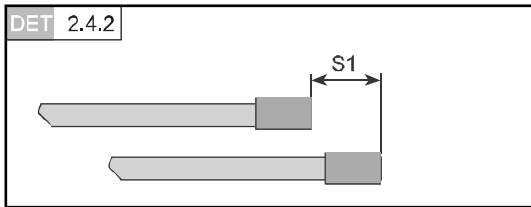

i

S1* Safety distances depending on Woodwork:

For	D20, T20, F20, R20, T35, D35	S1 = 0mm
For	E20	S1 = 50mm
For	I30	S1 = 55mm
For	C44	S1 = 105mm
For	S44	S1 = 105mm

2.3.2 DOOR HEIGHT

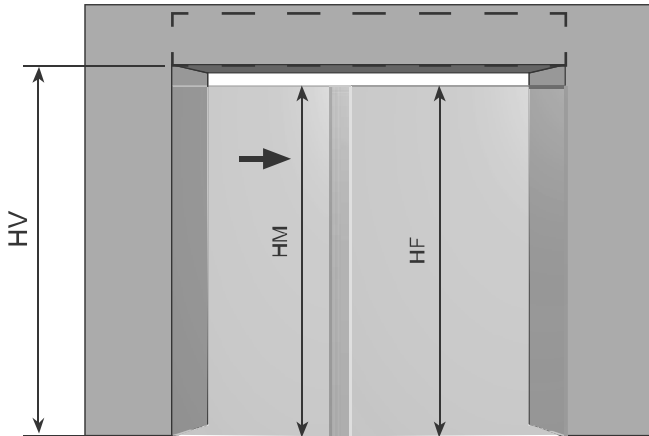

Fig. 2.5

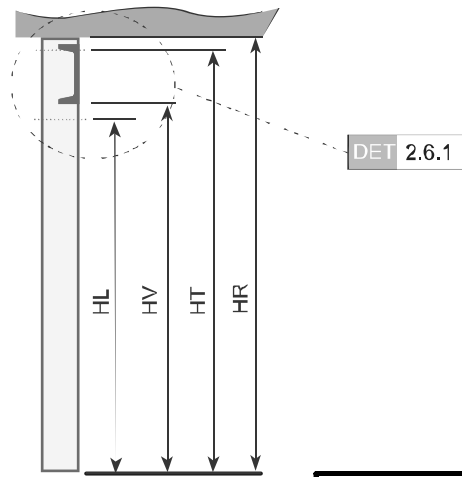
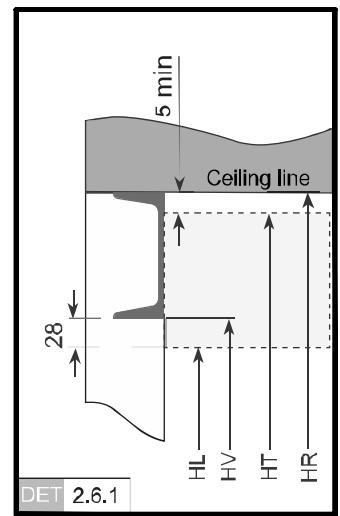

Fig. 2.6



i	HL	Door clear height
	HT = HL + 125	Overall door height
	HR = HT + (5min)	Minimum ceiling height
	HV = HL + 28	Beam height

Fig. 2.5 Fig. 2.6

2.4 CHECKS

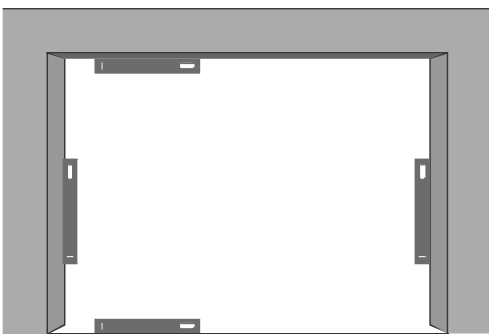

Fig. 2.7

i Check the floor level, beam and walls overhang.
FIG Fig. 2.7

Check AH for the whole opening as per Fig 2
Fig. 2.8

Check that minimum HV = HL+28 for the whole opening
Fig. 2.9

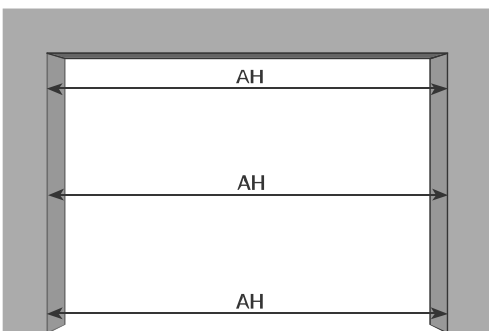

Fig. 2.8

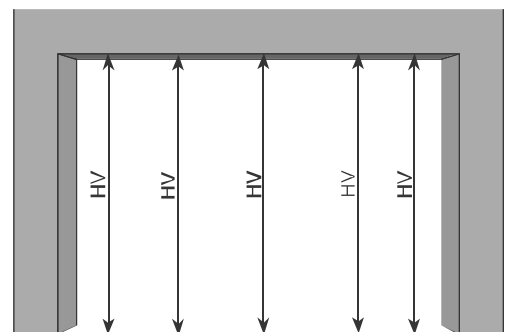

Fig. 2.9

Visio Lateral 1 Leaf Operator

Assembly f3

Prepare main profile

3.1 WHAT WE NEED AND WHERE TO FIND IT.

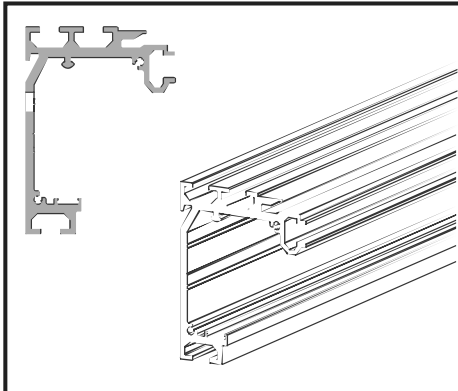

Ref	Description	Location
PACIPP	Visio Chassis al. B. main profile	Box 2

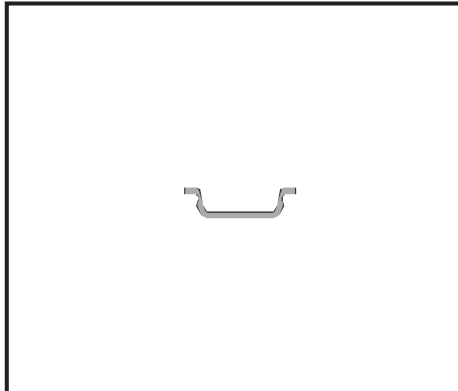

Ref	Description	Location
JUCIAR	Visio ch. join wheel-track ins.	Box 2

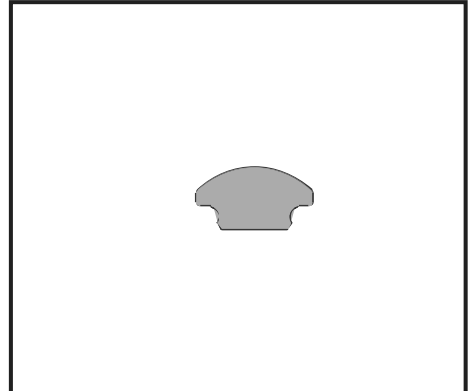

Ref	Description	Location
PACIPR	Visio chassis wheel-track	Box 2

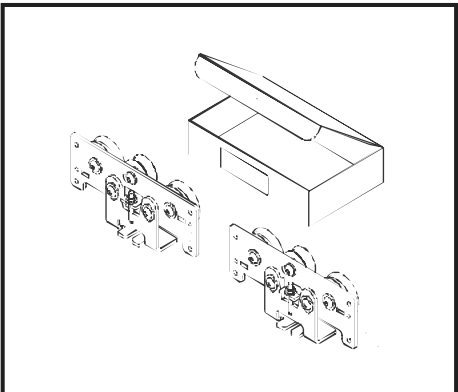

Ref	Description	Location
CACI01	Visio sliding leaf trolley	Box 3

3.2 DRILLING

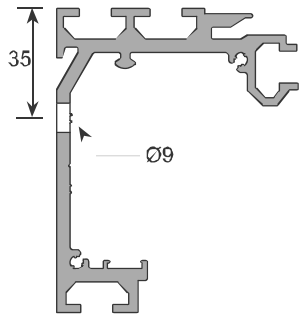

Fig. 3.1

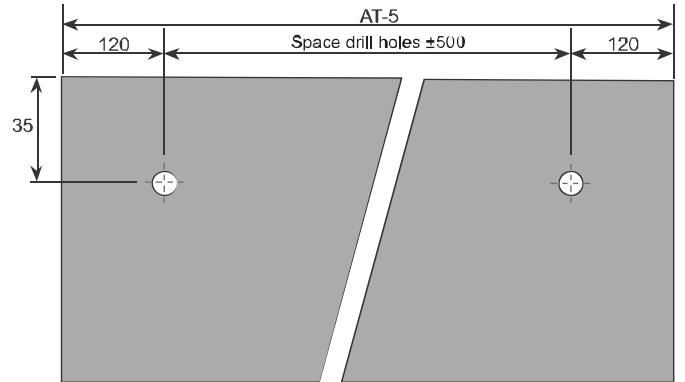

Fig. 3.2

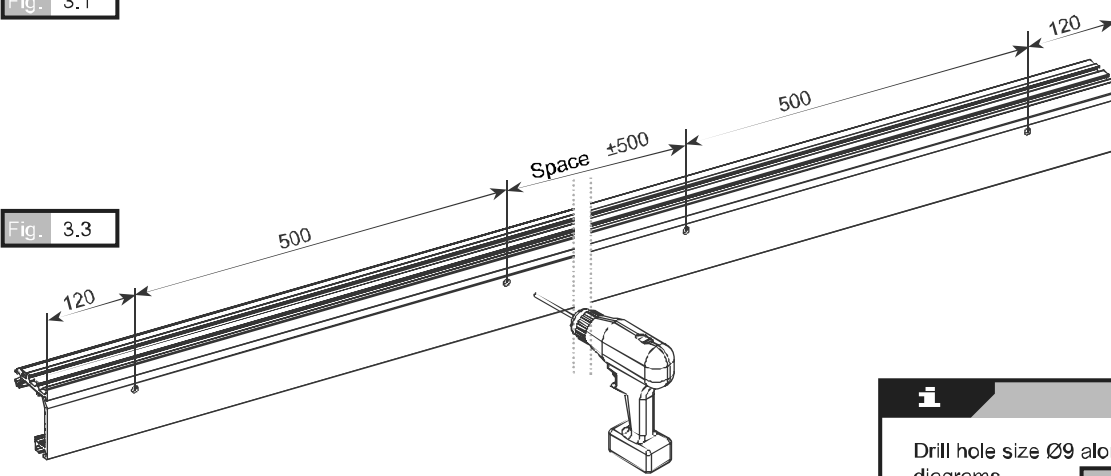

Fig. 3.3

Tools



Drill bit no.9

i Drill hole size Ø9 along main profile as shown in diagrams. [Fig. 3.1](#) [Fig. 3.2](#)

3.3 TRACK PROFILE ASSEMBLY

3.3.1 INTRODUCE

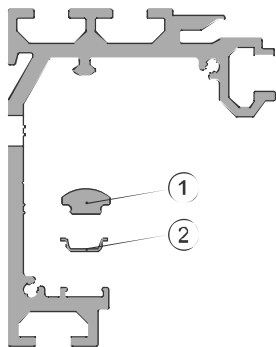

Fig. 3.4

i

1. Track profile	Length = AT-20mm
2. Insulation profile	Length = AT-20mm

[Fig. 3.4](#)

3.3.2 POSITION

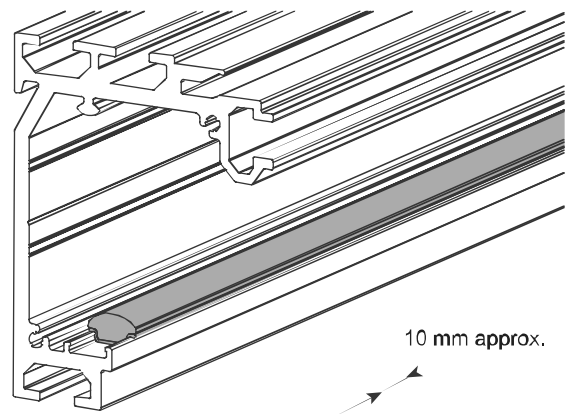
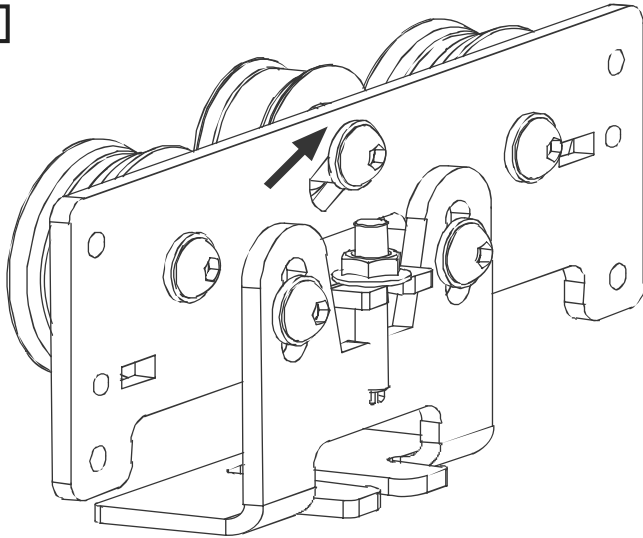

Fig. 3.5

i Keep a distance of 10mm to the right and left of the main profile. [Fig. 3.5](#)

3.4 ADJUST TRACK PROFILE

Fig. 3.6



Use a previously assembled trolley as shown in the diagram. **Fig. 3.6**

Adjust the top wheel as shown in diagram. **Fig. 3.6**

Introduce the trolley on the top stile as shown in diagram. **Fig. 3.7**

Slide the trolley along the whole length of the main profile as shown in the diagrams. **Fig. 3.8**

Use a hand to help position the track rail.

Fig. 3.7

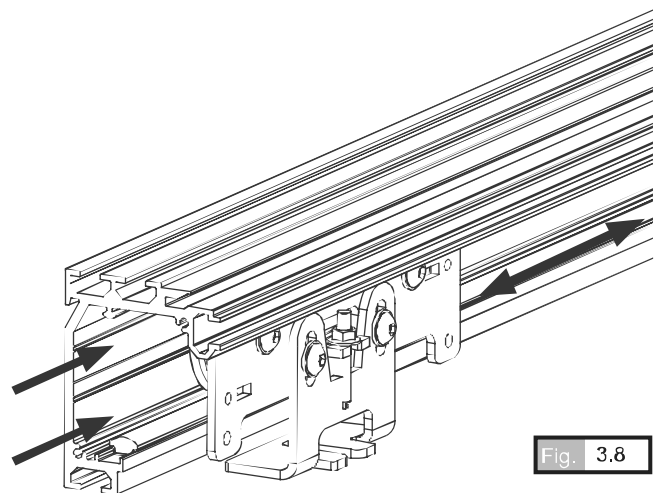
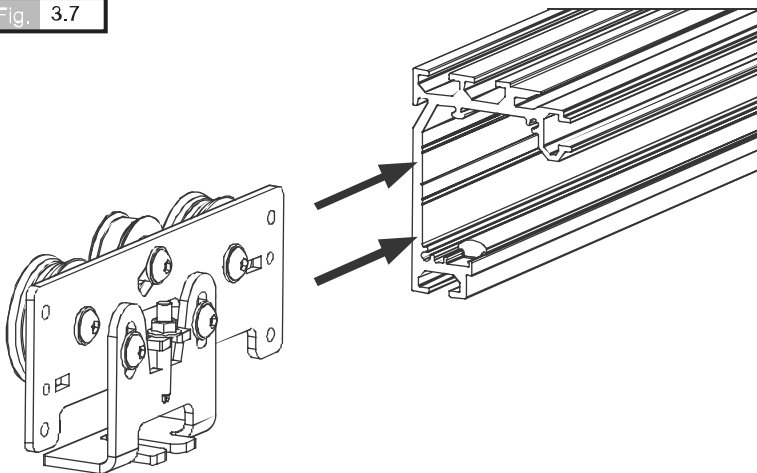

Fig. 3.8

Visio Lateral 1 Leaf Operator

Assembly f4

Main profile and top lintel assembly.

4.1 WHAT WE NEED AND WHERE TO FIND IT.

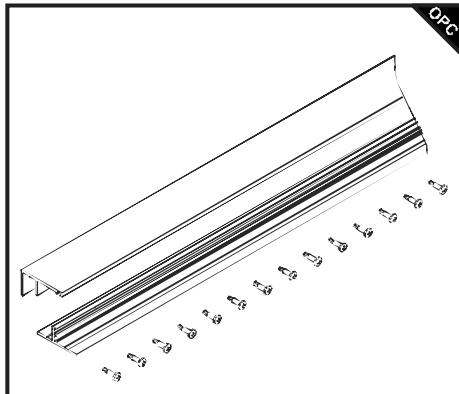

Ref	Description	Location
KCI125HF	Visio fixed leaf pack	Box 2

4.2 PROFILES LAYOUT

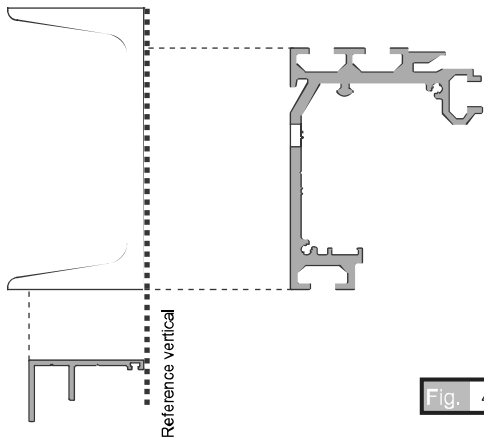

Fig. 4.1

 Set out the sections as shown in the diagram.

Fig. 4.1

4.3 TOP LINTEL ASSEMBLY

4.3.1 Mark and screw.

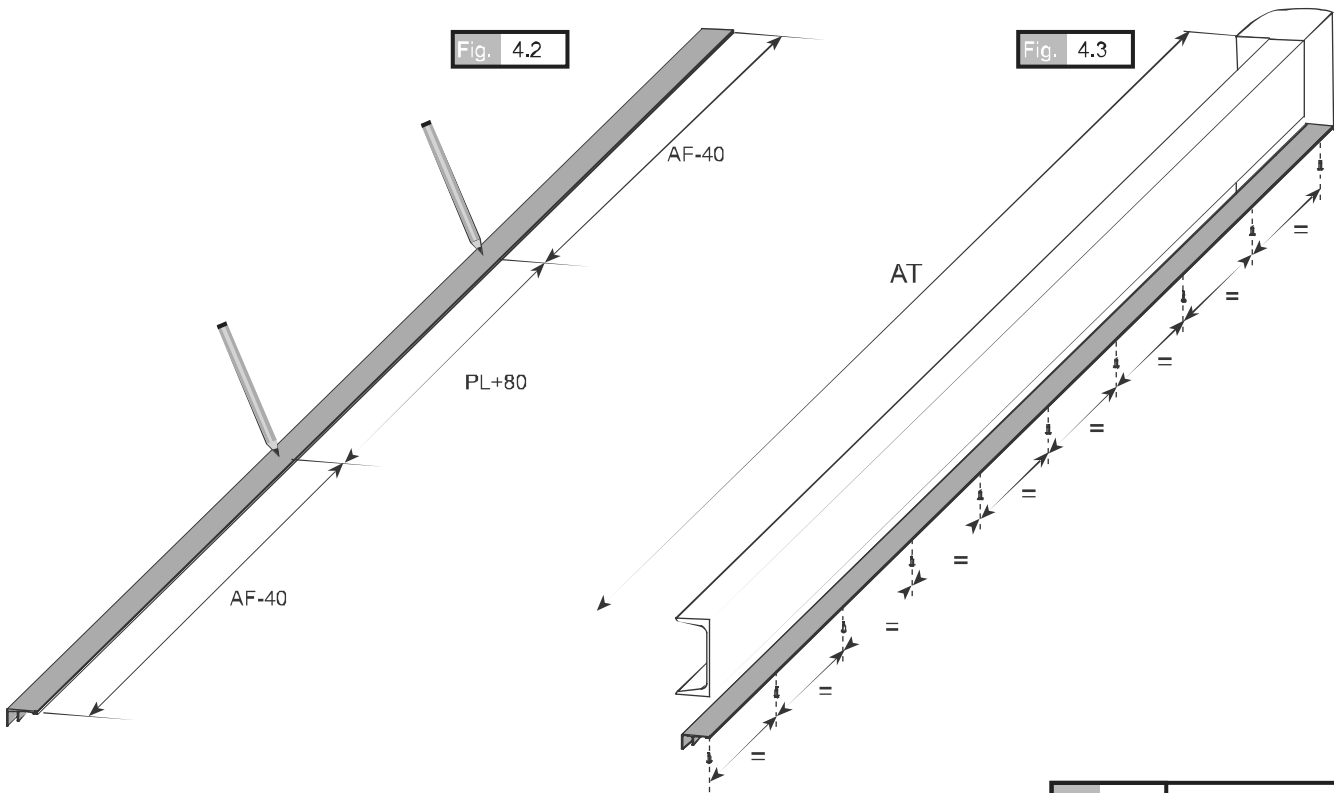

Fig. 4.2

Fig. 4.3

 Make marks in the top lintel as shown in the diagram.

Fig. 4.2

Self thread top lintel to the C-beam x10 self-threading screws placed at equal intervals along the length of the profile, as shown in the diagrams.

Fig. 4.3

Fig. 4.3

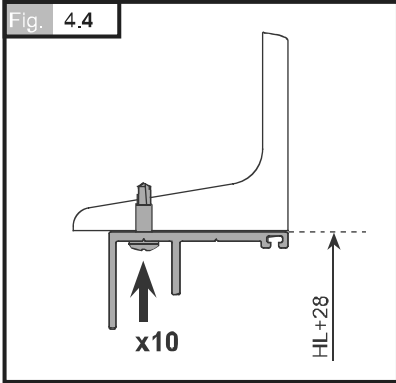

Fig. 4.4

4.4 MAIN PROFILE ASSEMBLY

4.4.1 INTRODUCE AND MARK

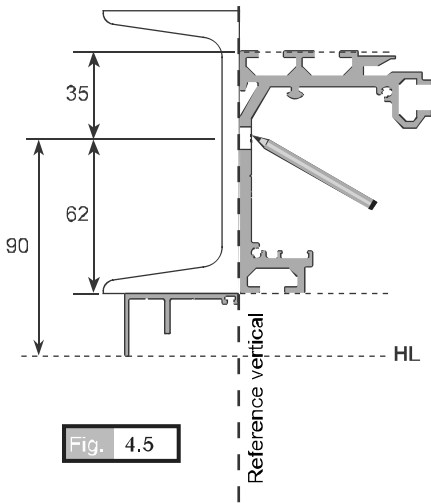

Fig. 4.5

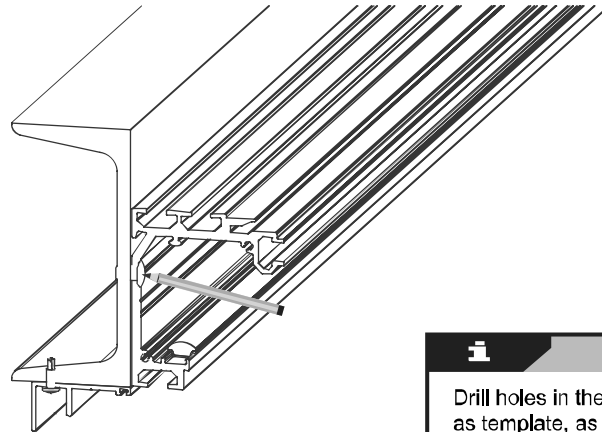

Fig. 4.6

i
 Drill holes in the beam using the main profile as template, as shown in the diagrams.
 Fig. 4.5 Fig. 4.6

4.4.2 DRILL

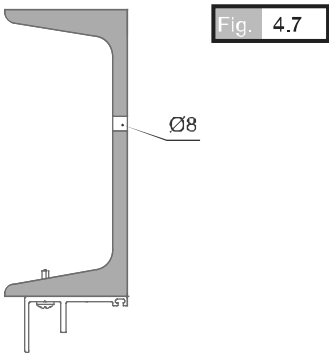

Fig. 4.7

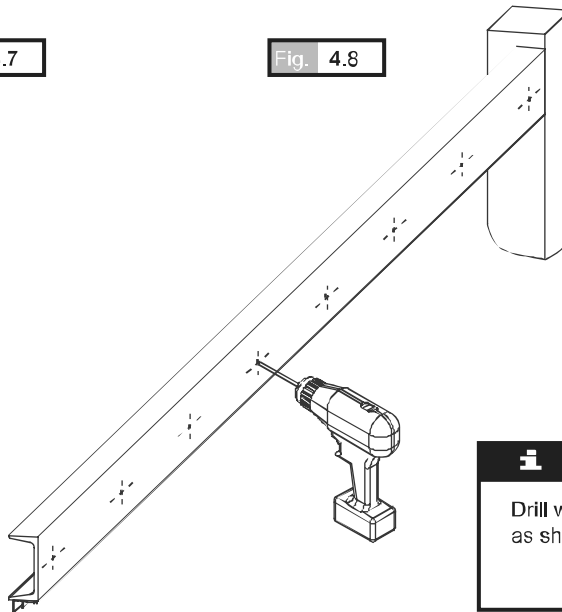

Fig. 4.8

Herramientas

Drill Ø8

i
 Drill where marked along the length of the UPN at Ø8, as shown in the diagrams.
 Fig. 4.7 Fig. 4.8

4.4.3 SCREW

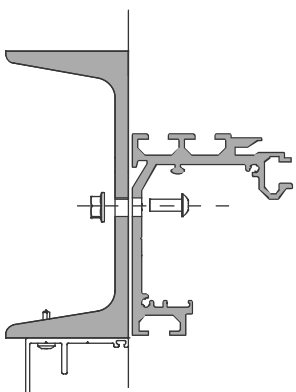

Fig. 4.9

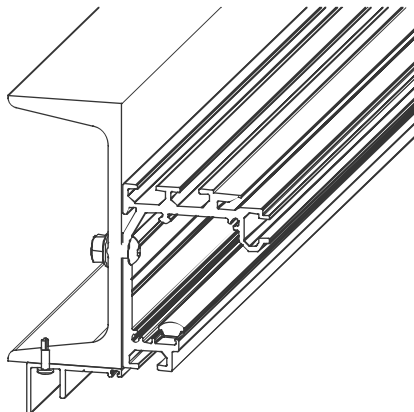

Fig. 4.10

Nuts & bolts	Nuts & bolts
DIN6923 M8	SO7380 M8x20

i
 Screw main profile to the UPN as shown in the diagrams.
 Fig. 4.9 Fig. 4.10

Visio Lateral 1 Leaf Operator

Assembly f5

Prepare bottom lintel.

5.1 WHAT WE NEED AND WHERE TO FIND IT.

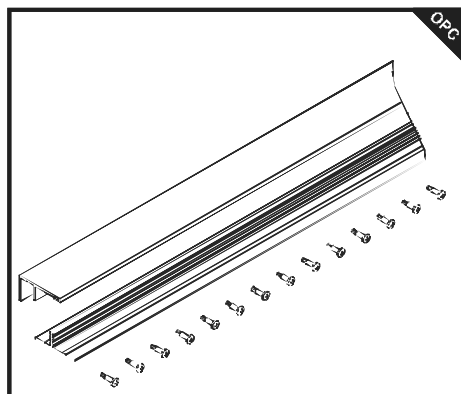

Ref	Description	Location
KCI125HF	Visio fixed leaf pack	Box 2

5.2 CUT

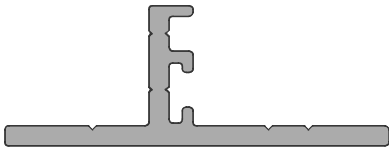

Fig. 5.1

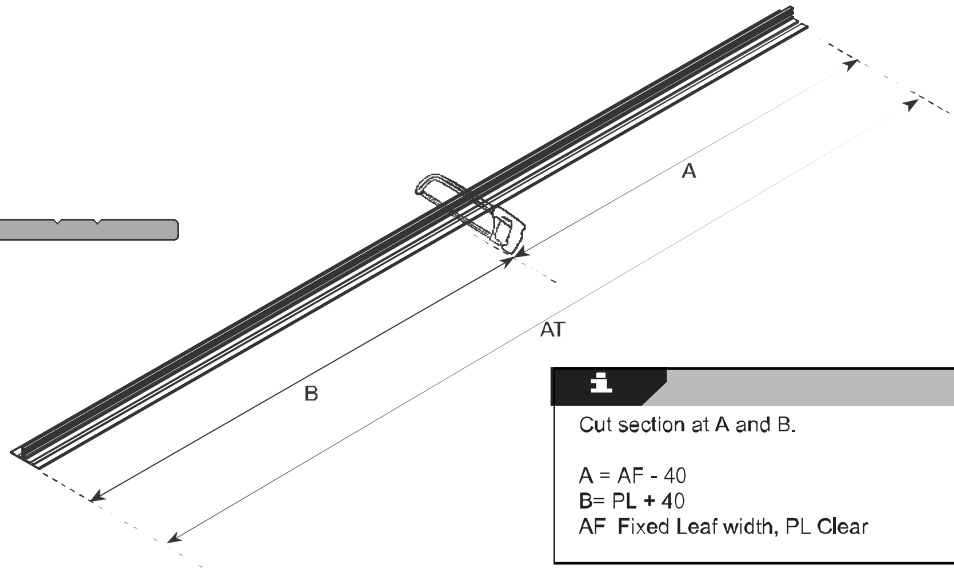

Fig. 5.2

i Cut section at A and B. Fig. 5.2.1

A = AF - 40
 B = PL + 40
 AF Fixed Leaf width, PL Clear

5.3 DRILLING

Tools

Drill bit no. 8'5/5

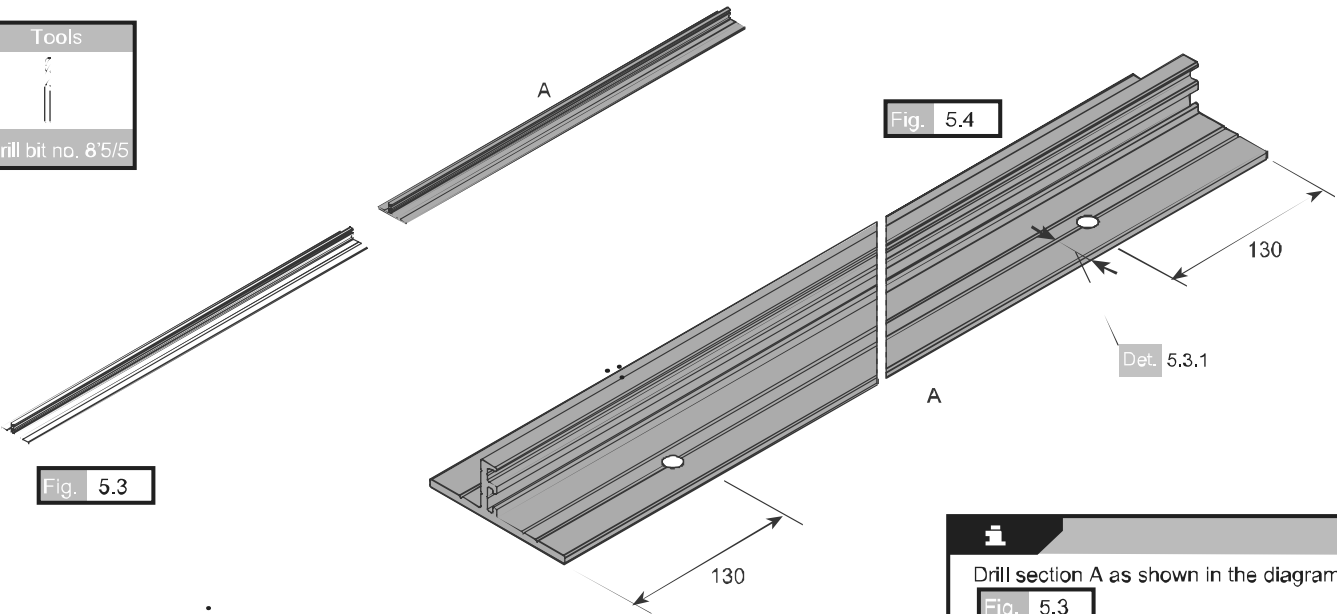

Fig. 5.3

Fig. 5.4

Det. 5.3.1

i Drill section A as shown in the diagram. Fig. 5.3

See table for different woodwork dimensions. Det. 5.3.1

Det. 5.3.1				
Woodw. E20	Woodw. D35	Woodw. 40	Woodw. 130	Woodw. 44

5.2.3 Screw.

Fig. 5.4

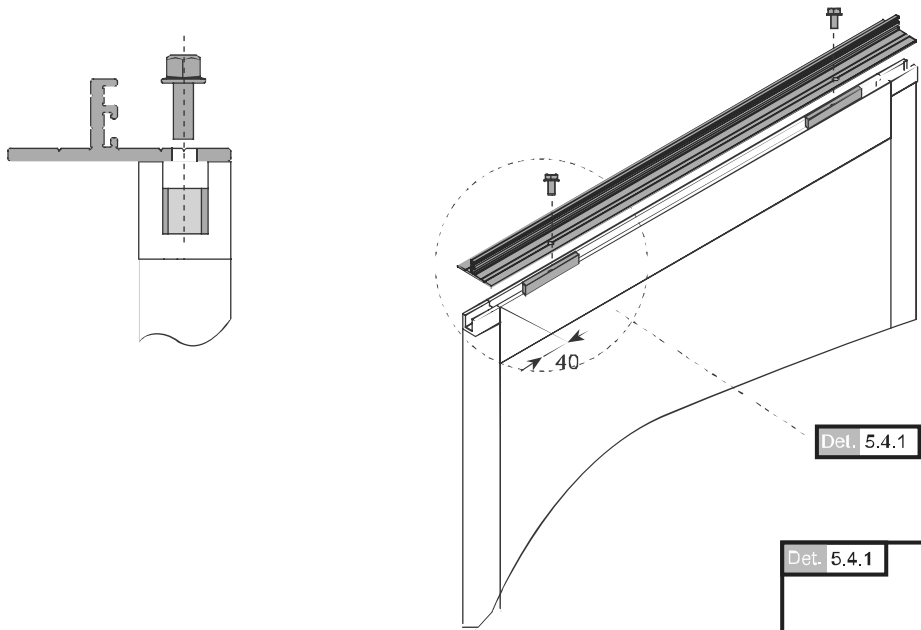

Nuts & bolts

DIN6923 M8

i
 Screw the bottom lintel to the fixed leaf as shown in the diagram.
Fig. 5.4
 Leave 40mm in the PL part of the door leaf. **Det. 5.4.1**
 Check table for different woodwork dimensions. **Det. 5.4.2**

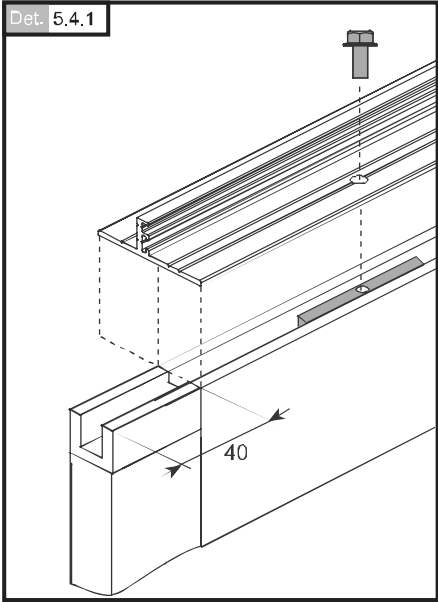

Det. 5.4.2	Woodw. E20	Woodw. D35	Woodw. I30	Woodw. 40	Woodw. 44



Visio Lateral 1 Leaf Operator

Assembly f6

Fixed leaves / bottom lintel (PL) assembly

6.1 WHAT WE NEED AND WHERE TO FIND IT.

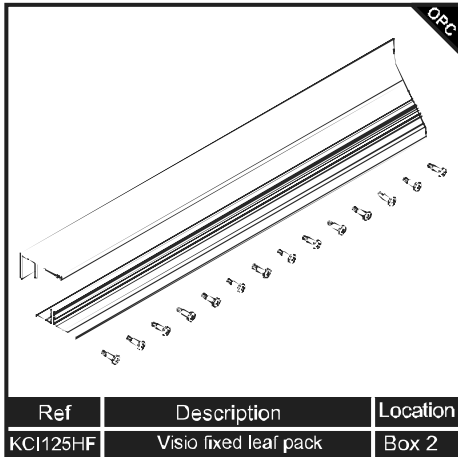

6.2 DRILLING

i
 Mark and drill the floor on the inside of the AT in accordance with dimensions. **Fig. 6.1**
 Mark and drill with respect to the reference vertical, according to woodwork dimensions **Fig. 6.2** **DET 6.2.1**

Tools	Nuts & bolts	Nuts & bolts
		
Drill bit no. 6	DIN912 6x20	Rawlplug S-6

Fig. 6.1

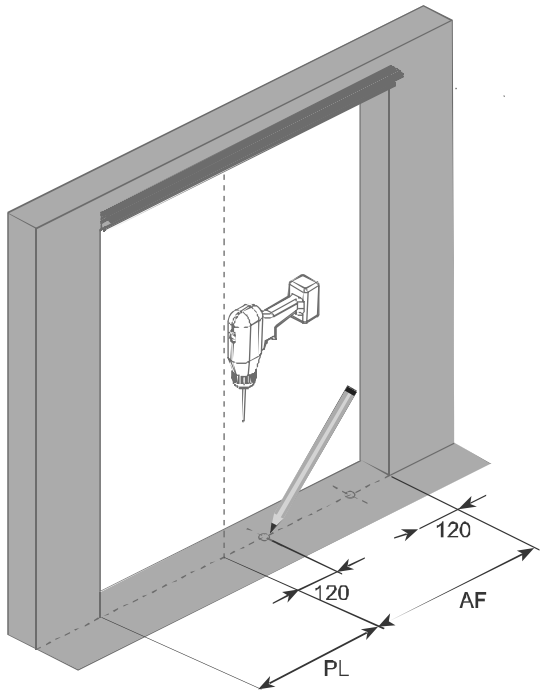
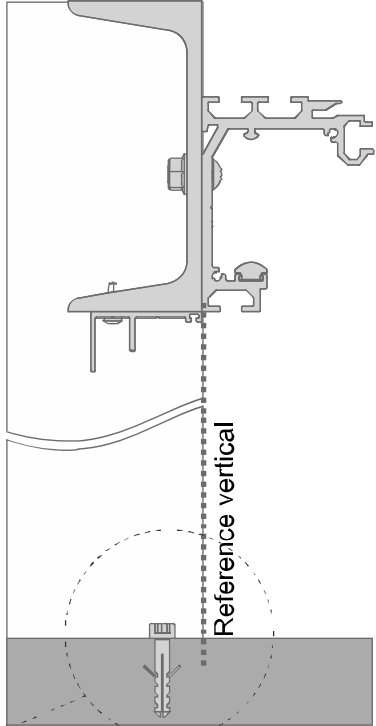

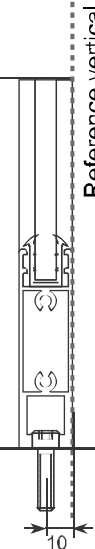

Fig. 6.2



DET 6.2.2

Variable depending on woodwork dimensions

DET 6.2.1

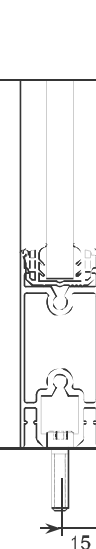
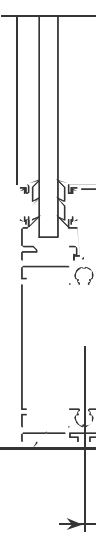
Woodw. E20	Woodw. D35	Woodw. I30	Woodw. 40
			
10	10	15	22

6.3 POSITION FIXED LEAVES

Fig. 6.3

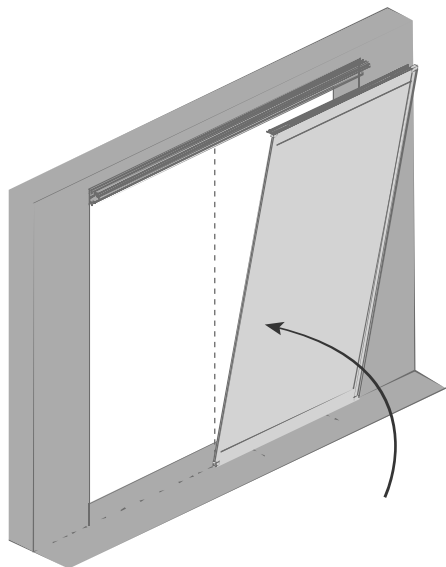

i
Position the fixed leaves as shown in the diagrams.
Fig. 6.3/6.4/6.5

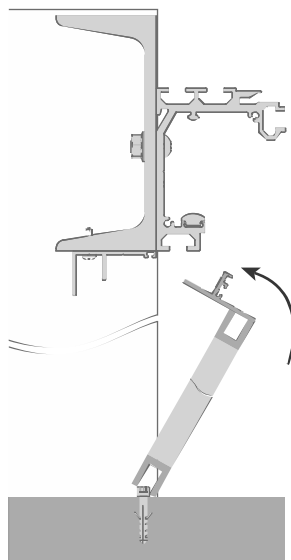

Fig. 6.4

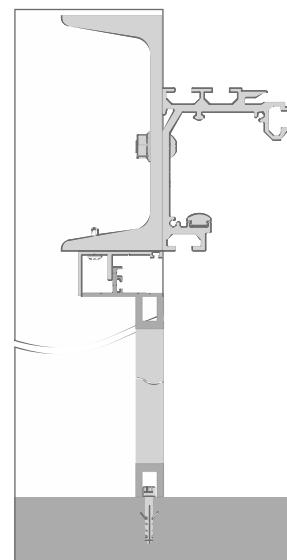

Fig. 6.5

6.4 CHECK FOR PLUMB

i
Check door leaves (PL) are parallel throughout the clear height.
Fig. 6.6

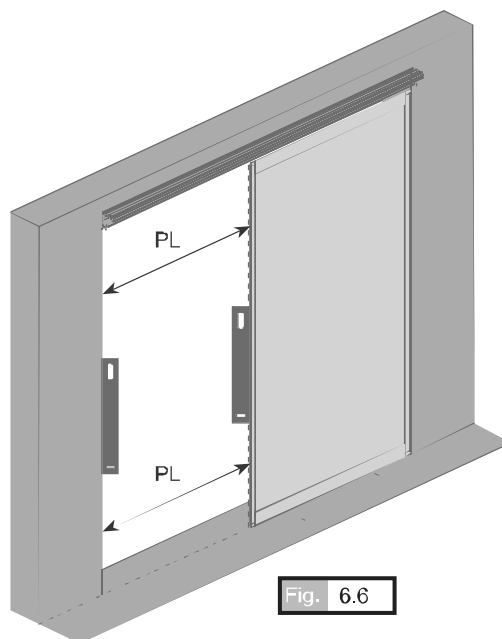

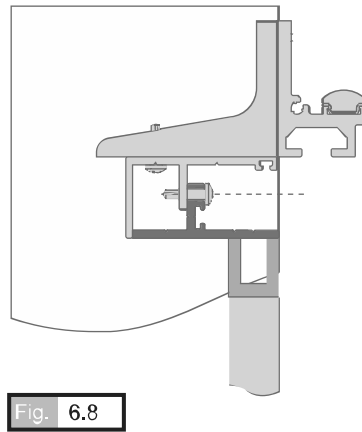
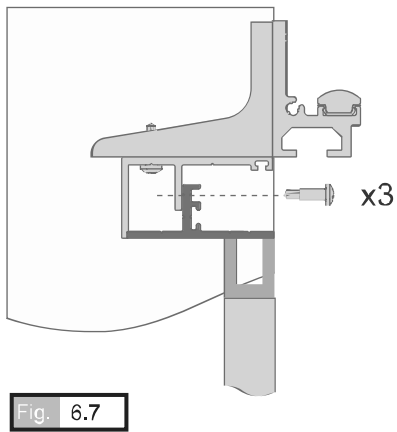

Fig. 6.6

6.5 SCREW

i
 Screw (x3) fixed leaves to top lintel.
 Fig. 6.7/6.8

Nuts & bolts

 D-7504N 4.2x16

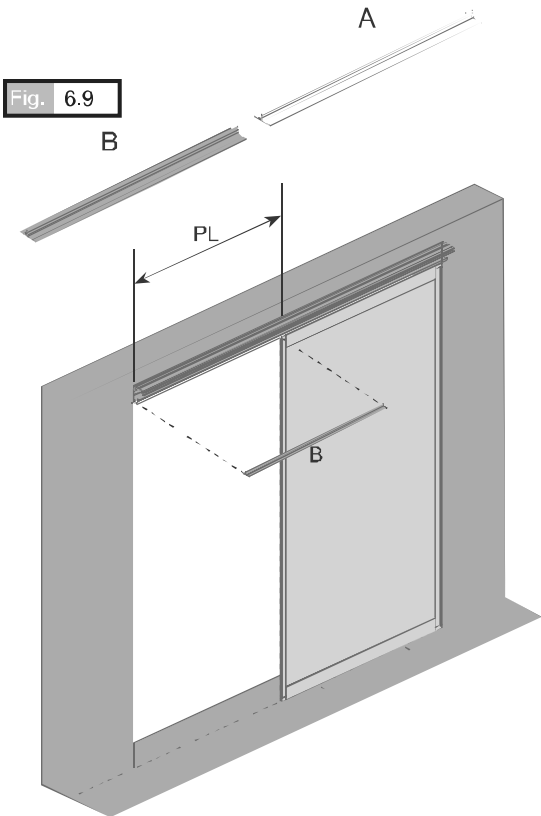

6.6 SCREW



i
 Screw (x3) bottom lintel (PL) to top lintel.
 Fig. 6.9/6.10/6.11

Tornilleria

 D-7504N 4,2x16

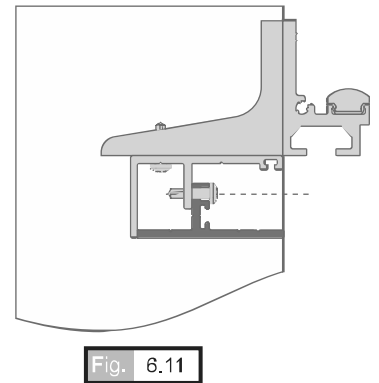
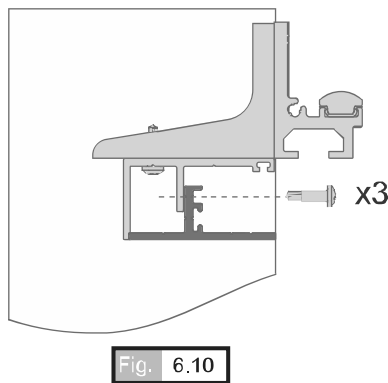



Visio Lateral 1 Leaf Operator

Assembly f7

Lateral stops / lock assembly

7.1 WHAT WE NEED AND WHERE TO FIND IT.

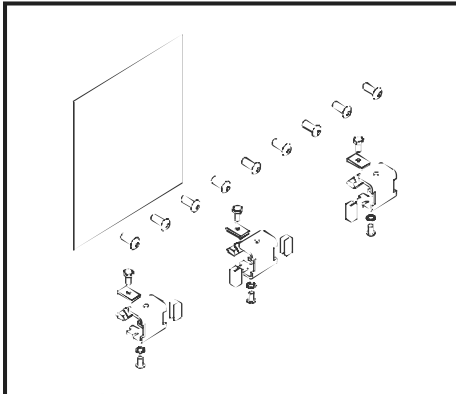

Ref	Description	Location
KCIP0101	Visio chassis main frame pack	Box 2

7.2 LATERAL STOPS ASSEMBLY

7.2.1 Insert nuts into profile.

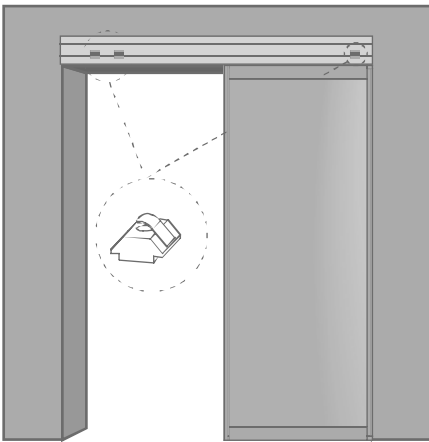
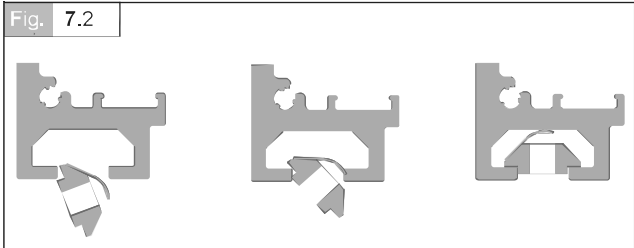

Fig. 7.1

i
 Insert 4 nuts distributed in the AT as shown in the diagram.
 Fig. 7.1
 Insert the nuts in the bottom channel of the main profile.
 Fig. 7.2



7.2.2 Lateral stops assembly.

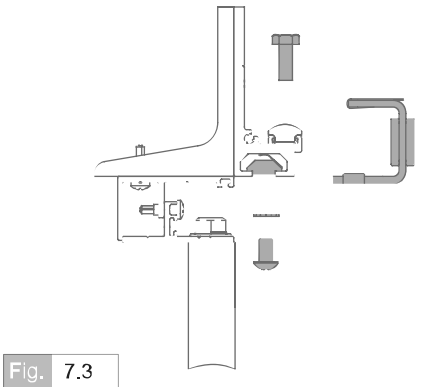

Fig. 7.3

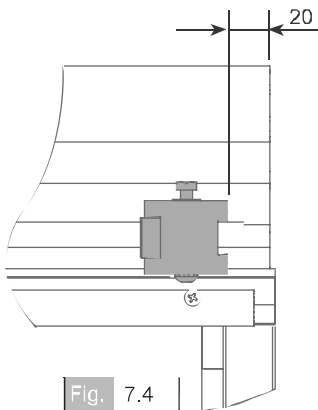

Fig. 7.4

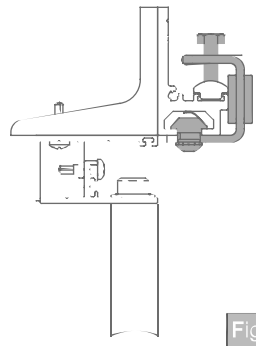
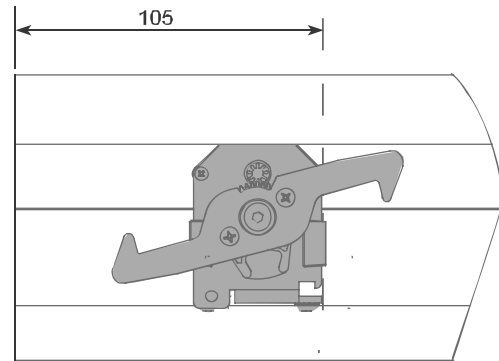
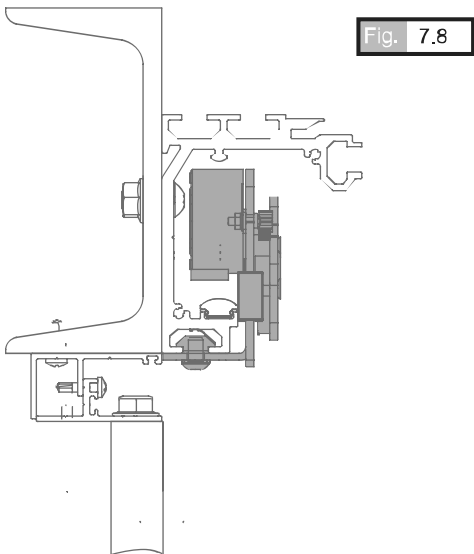
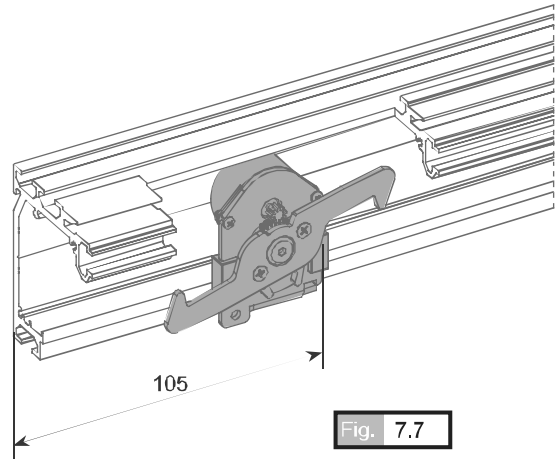
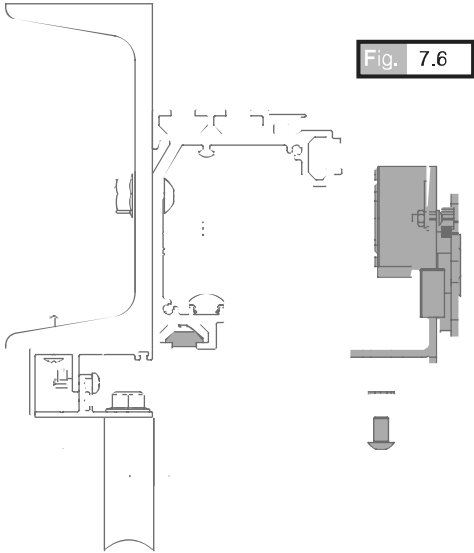

Fig. 7.5

i
 Introduce lateral end stops and screws/nuts into main profile. Fig. 7.3
 Position stops at the two ends of the main profile. Fig. 7.4
 Screw to the nut inside the channel, and tighten the screw over the track rail.
 Fig. 7.5

Nuts & bolts	Nuts & bolts	Nuts & bolts
DIN7380 6x10	DIN6798 M-6	DIN933 6x12

7.3 LOCK ASSEMBLY.



i

Introduce lock and screws/nuts into centre of main profile. **Fig. 7.6**

Position the lock at AT/2. **Fig. 7.7**

Screw nuts inside channel. **Fig. 7.8**

Nuts & bolts



DIN7380 6x10

Nuts & bolts



DIN6798 M-6



Visio Lateral 1 Leaf Operator

Assembly f8

Dragging trolleys / arms assembly.

8.1 WHAT WE NEED AND WHERE TO FIND IT.

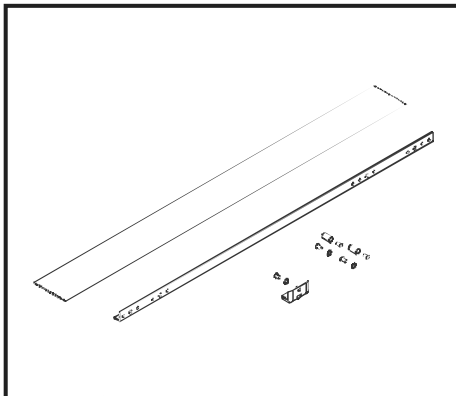

Ref	Description	Location
BRCI01	Visio dragging arm	Box 3

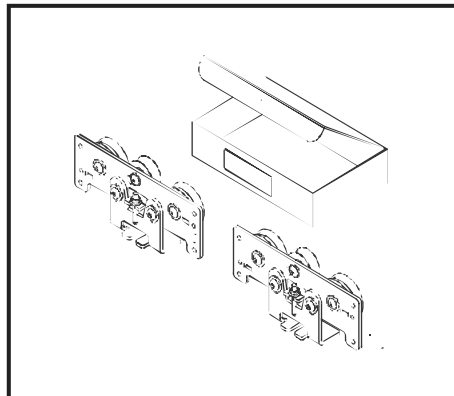

Ref	Description	Location
CACI01	Visio sliding leaf trolley	Box 3

3.2 TROLLEYS ASSEMBLY.

OPENING TO THE LEFT. ←

OPENING TO THE RIGHT. →

8.2.1 Distribute the trolleys in the operator

8.2.1 Distribute the trolleys in the operator

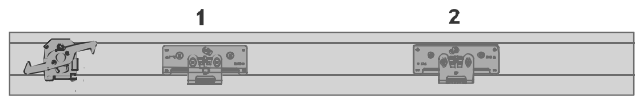
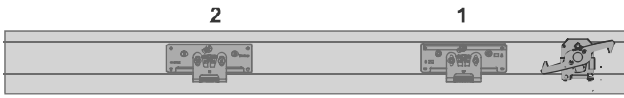

Fig. 8.1

Fig. 8.1

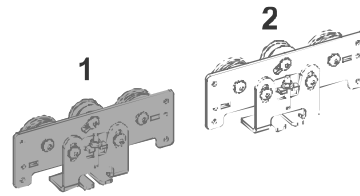
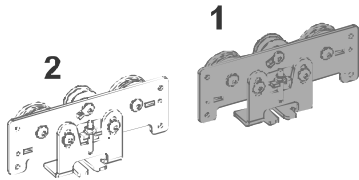

Fig. 8.2

Fig. 8.2



See the distribution of trolleys as per the scheme shown in the diagram. Fig. 8.1

For an easy assembly number them 1 to 2. Fig. 8.2

8.2.2 Separators on trolleys assembly.

8.2.2 Separators on trolleys assembly.

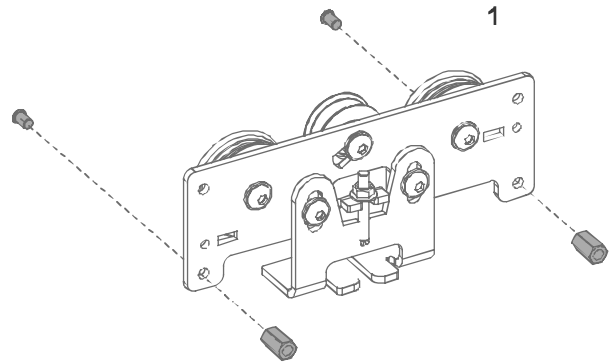
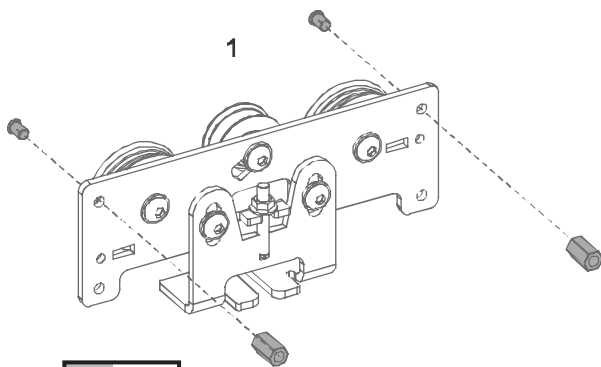

Fig. 8.3

Fig. 8.3

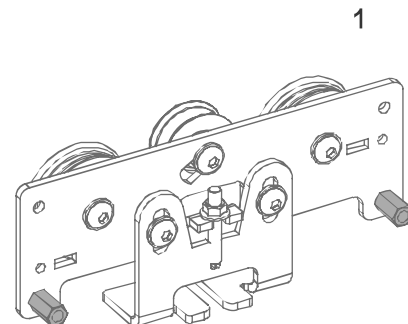
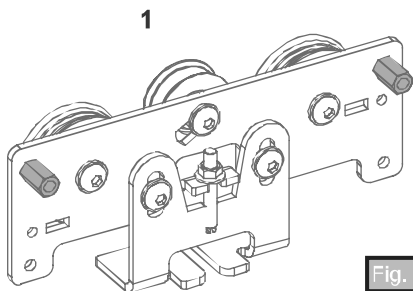
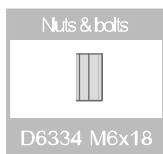
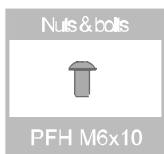

Fig. 8.4



Screw separators to trolleys no. 1 according to the layout shown in the diagrams. Fig. 8.3 Fig. 8.4

OPENING TO THE LEFT. ←

OPENING TO THE RIGHT. →

8.2.3 Lock hooks assembly.

8.2.3 Lock hooks assembly.

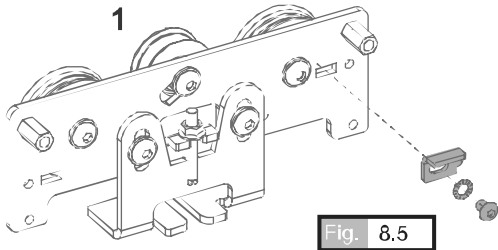

Fig. 8.5

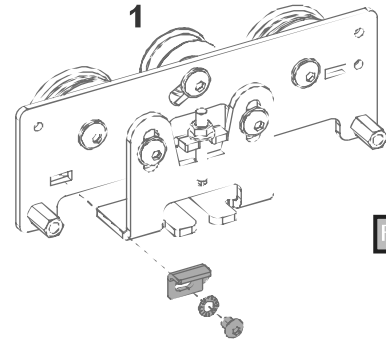

Fig. 8.5

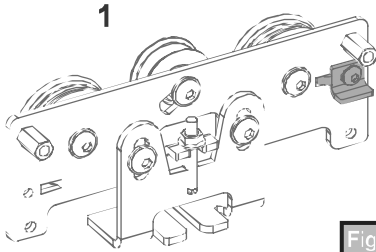

Fig. 8.6

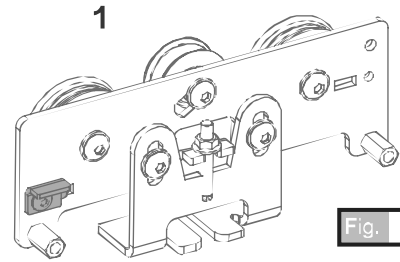



Fig. 8.6

Tools	Nuts & bolts
	
DIN7380 6x10	DIN6798 M-6



Attach lock hooks to trolleys 2-3 as shown in the diagrams.

Fig. 8.5

Fig. 8.6

8.3 INTRODUCE TROLLEYS INTO MAIN PROFILE

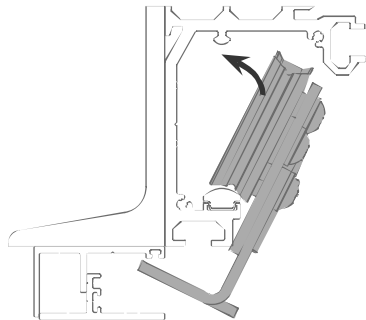

Fig. 8.7

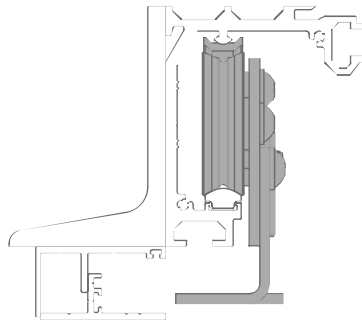

Fig. 8.8



Introduce the 2 trolleys into the main profile as shown in the diagrams.

Fig. 8.7

Fig. 8.8

Adjust the top wheel in the 2 trolleys as shown in the diagrams.

Fig. 8.9

DET 8.9.1

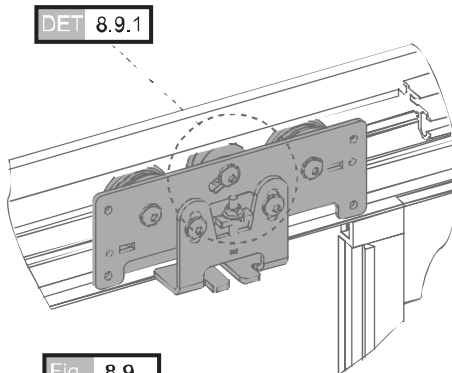
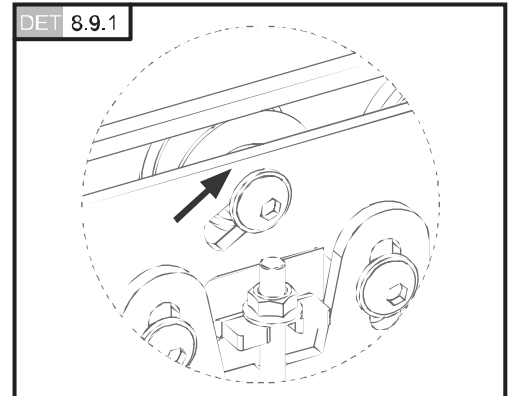

Fig. 8.9



DET 8.9.1

8.4 DRAGGING ARMS ASSEMBLY.

8.4.1 Cut arms.

Fig. 8.10

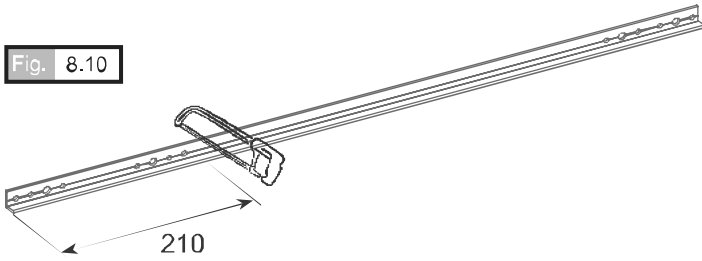

i
Cut arms as shown in diagram.
Fig. 8.10

OPENING TO THE LEFT. ←

8.4.2 Arms on trolleys assembly.

Fig. 8.11

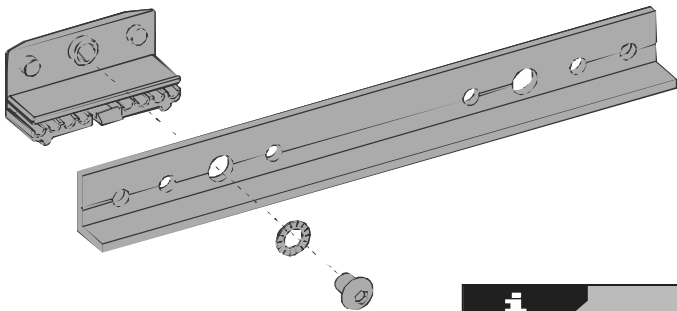

OPENING TO THE RIGHT. →

8.4.2 Arms on trolleys assembly.

Fig. 8.12

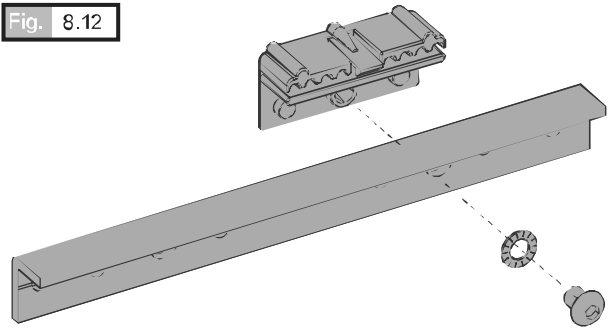

i
Screw anchors to arms as shown in diagram. DET 8.11 DET 8.12

OPENING TO THE RIGHT. →

8.4.3 Arms on trolleys assembly.

Fig. 8.13

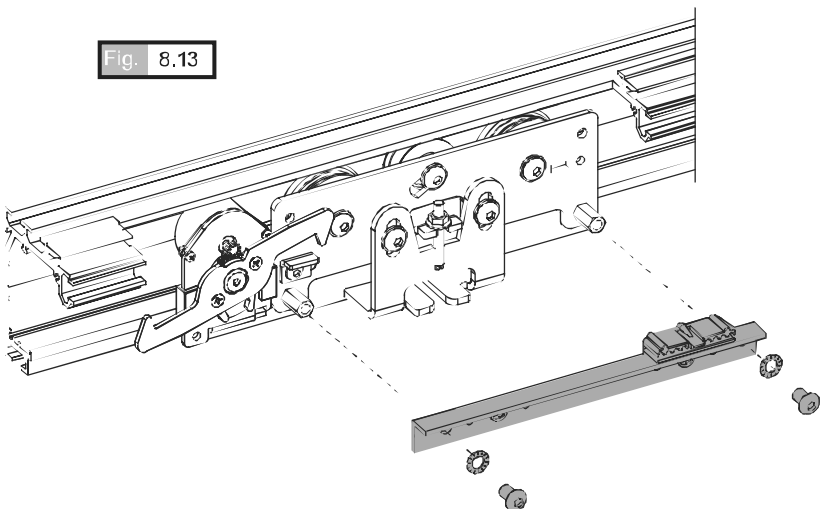

Nuts & bolts	Nuts & bolts
DIN7380 6x10	DIN6798 M-6

i
Screw right hand arm to right hand trolley (1) as shown in the diagram.
Fig. 8.13

OPENING TO THE LEFT. ←

8.4.4 Arms on trolleys assembly.

Fig. 8.14

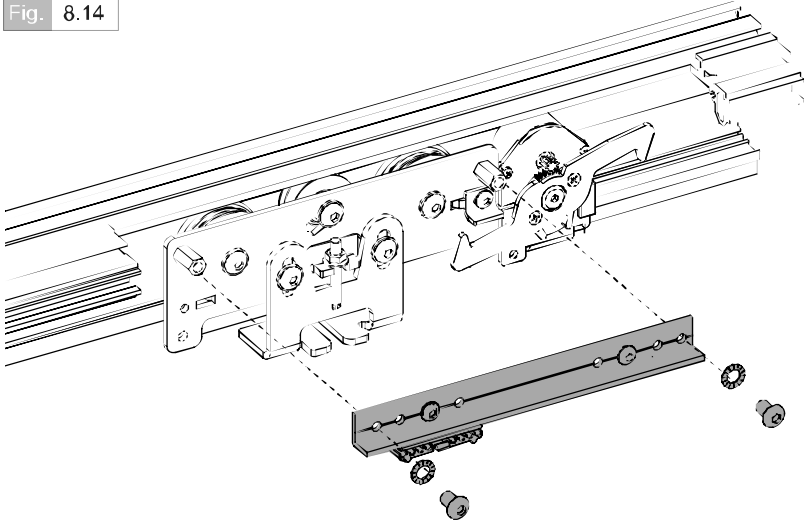

Nuts & bolts	Nuts & bolts
	
DIN7380 6x10	DIN6798 M-6

 Screw left hand arm to left hand trolley (1) as shown in the diagram.
Fig. 8.14

8.5 FINAL LAYOUT OF TROLLEYS / ARMS

OPENING TO THE LEFT. ←

OPENING TO THE RIGHT. →

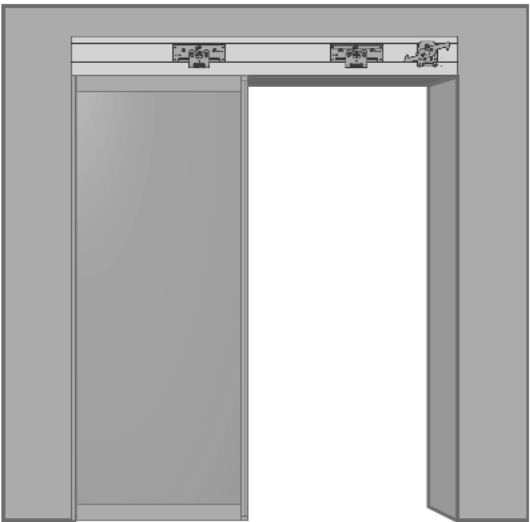

Fig. 8.15

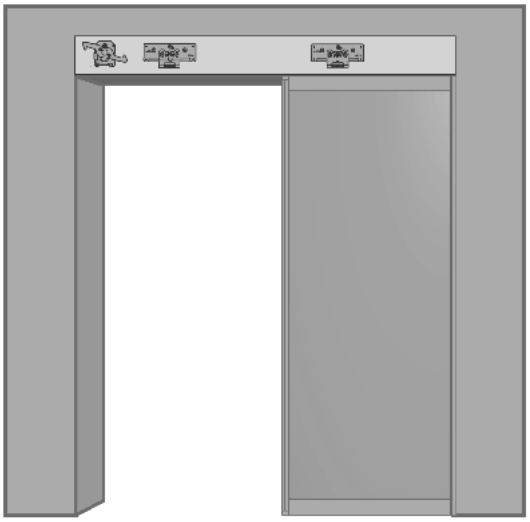



Fig. 8.16

 See correct layout once the trolley and arm assembly is complete.
Fig. 8.13



Visio Lateral 1 Leaf Operator

Assembly f9

Guide and sliding leaf assembly

9.1 WHAT WE NEED AND WHERE TO FIND IT.

9.2 FLOOR GUIDES ASSEMBLY.

9.2.1 Mark and drill the floor.

Fig. 9.1

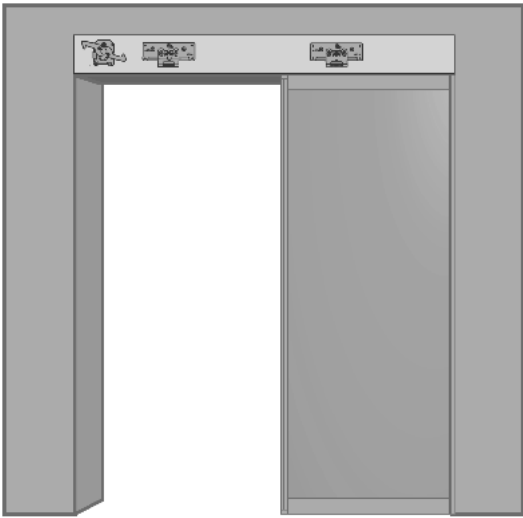

i

Floor guides position. (On the side of the fixed leaf as shown in the diagram) **Fig. 9.1**

Mark the floor, using the metal guide as a template. **Fig. 9.2**

Position the guide as shown in the diagram. **Fig. 9.3**

Drill the floor in accordance with the marks. **Fig. 9.4**

Fig. 9.2

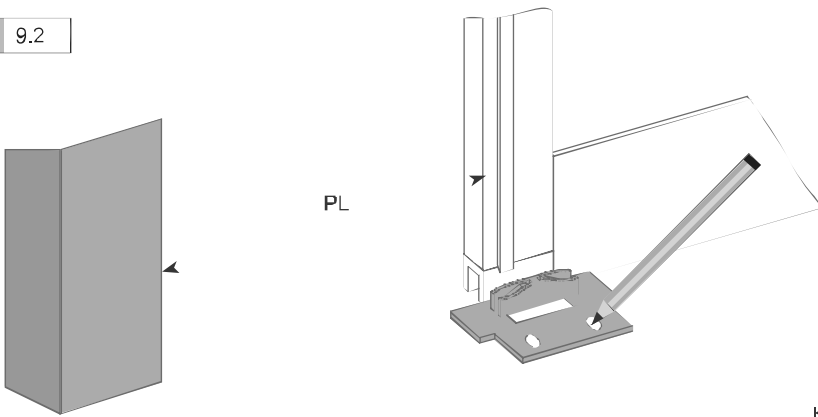

Fig. 9.3

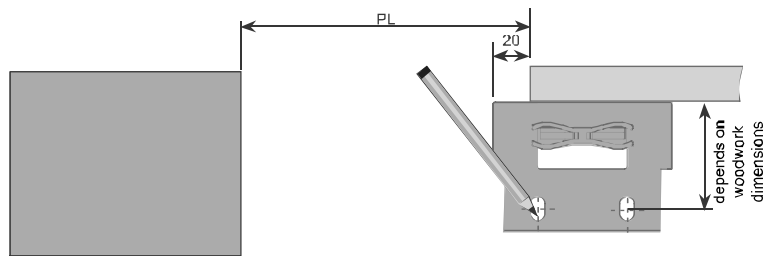
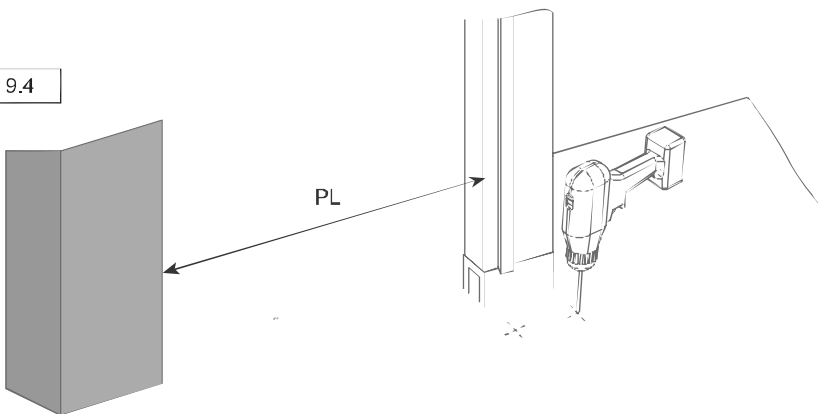

Fig. 9.4



9.2.2 Screw in the guides.

Fig. 9.5

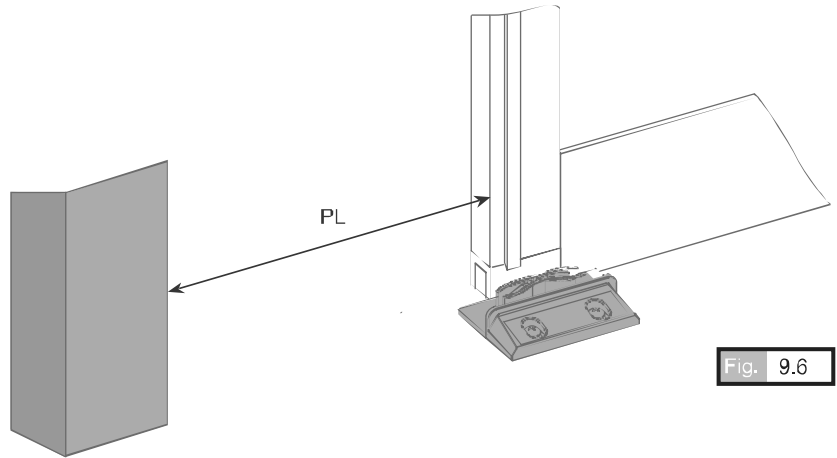
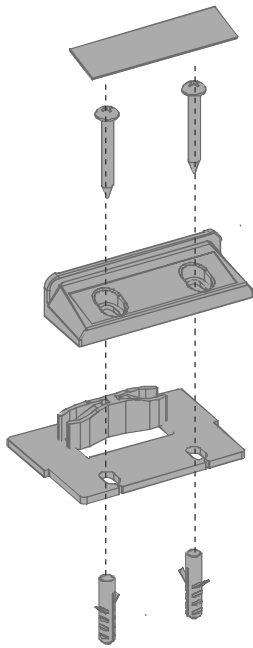



Fig. 9.6

 Insert rawplugs into the holes which have been drilled. Assemble guide as shown in the diagrams.
 Fig. 9.5 Fig. 9.6

9.3 SLIDING LEAVES ASSEMBLY.

9.3.1 Insert the screws into the square-section bars.

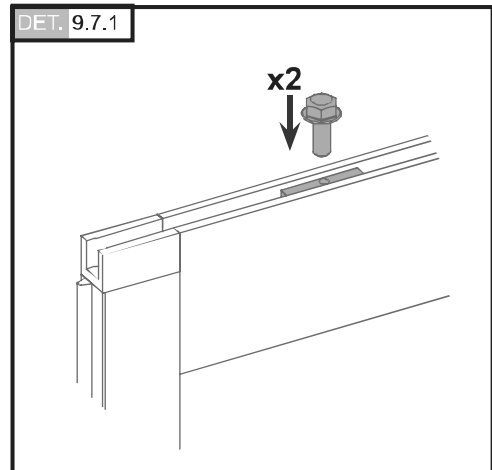
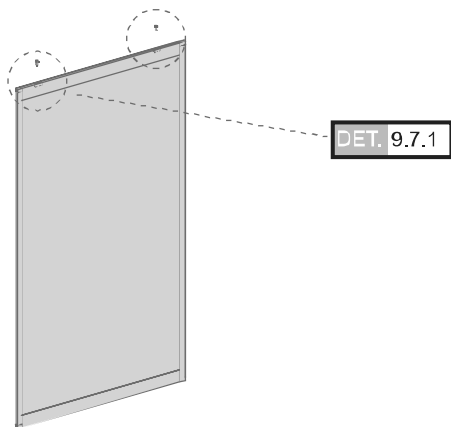
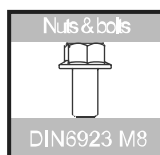



Fig. 9.7



 Screw in the screws (2x leaf) into the square section bars on the top of the sliding leaves.
 Fig. 9.7 DET. 9.7.1

9.3.2 Leaves hanger.

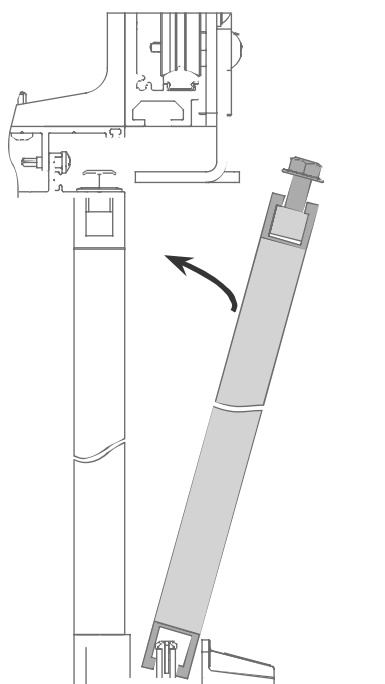

Fig. 9.8

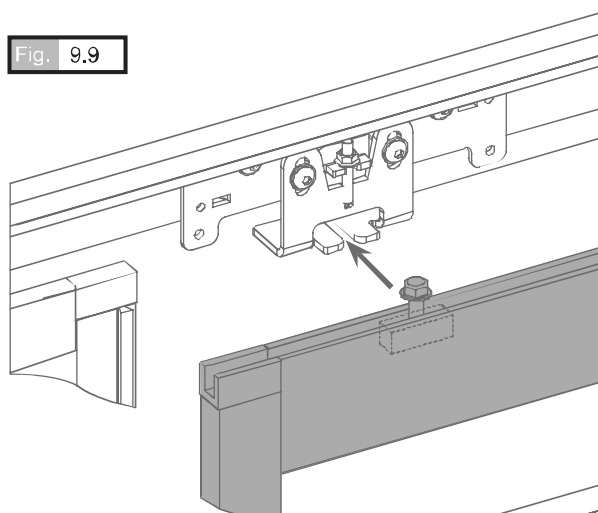

Fig. 9.9

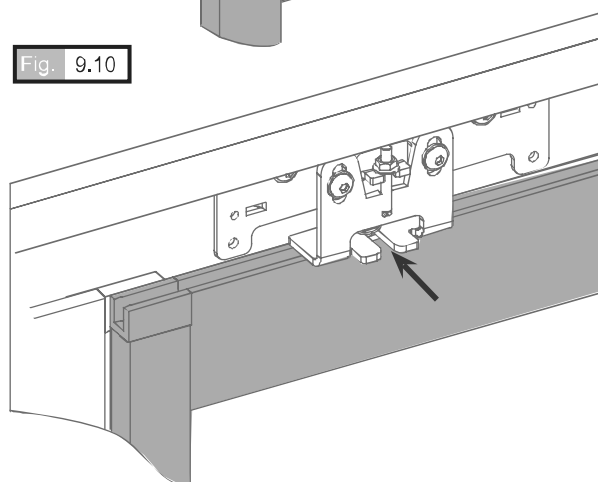

Fig. 9.10



Support the leaf on the guide as shown in the diagram. [Fig. 9.8](#)

Insert the screws so they hang from the trolleys as shown in the diagrams. [Fig. 9.9](#) [Fig. 9.10](#)

Position the trolleys with respect to the door leaves as shown in the diagrams. [Fig. 9.11](#) [Fig. 9.11.a](#)

Fig. 9.11

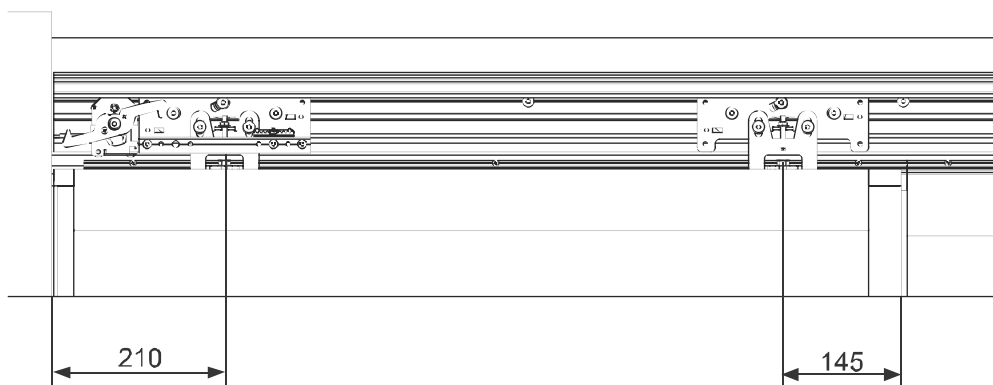

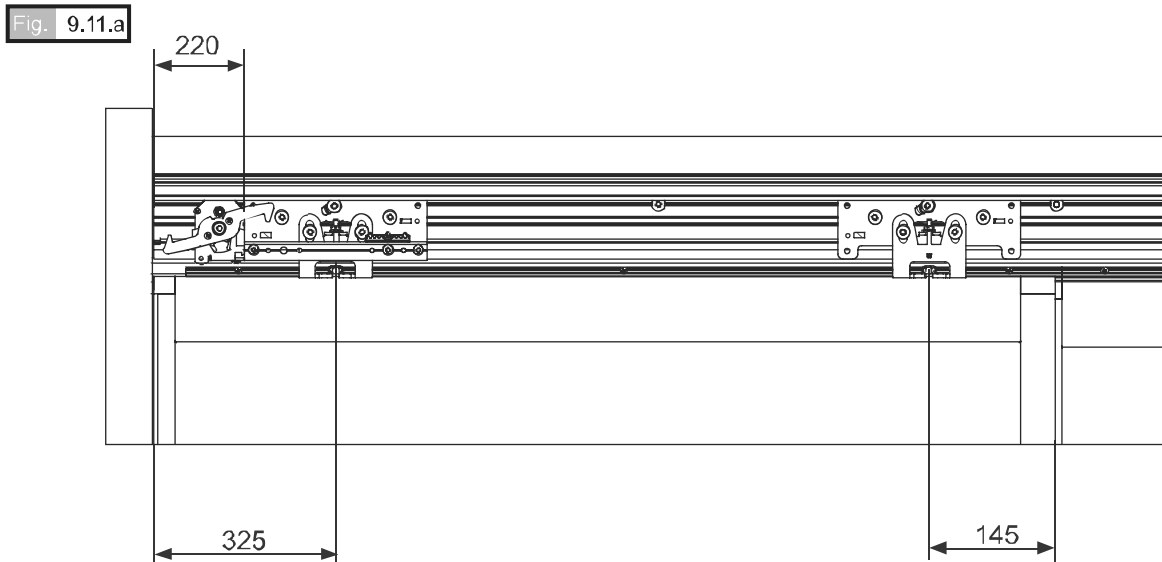

9.3.3 Adjust sliding leaves.

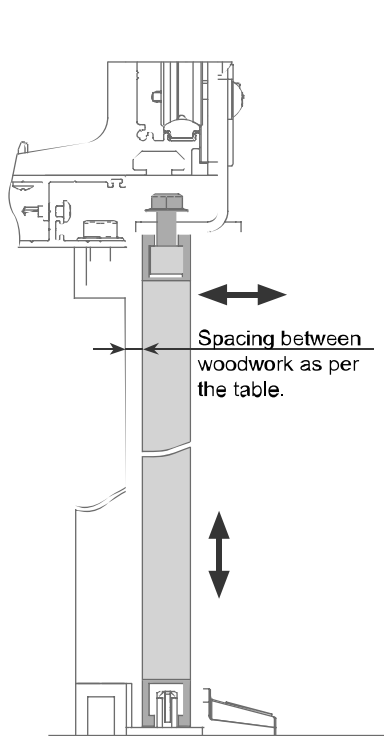

Fig. 9.12

Woodwork spacing table	
D20,F20,R20,T20,E20	6
T35,D35,S40	6
I30	15
C44,S44	26

Fig. 9.13

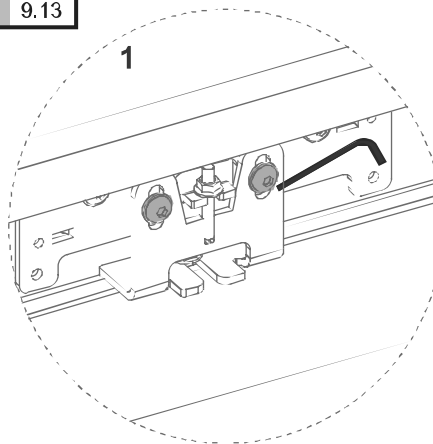
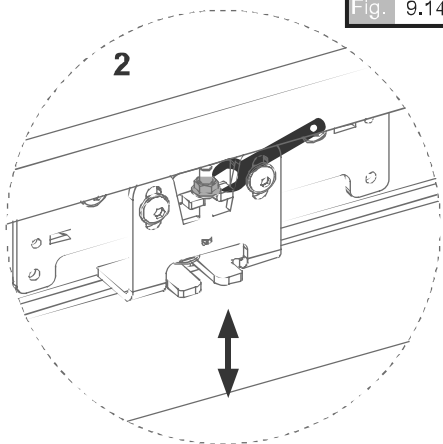

Fig. 9.14



i

Adjust depth of sliding leaves as shown in the diagram.

Fig. 9.12

To adjust height of sliding leaves:

- 1.- Loosen screws as shown in the diagram. Fig. 9.13
- 2.- Screw adjustment nut as shown in the diagram. Fig. 9.14

Visio Lateral 1 Leaf Operator

Assembly f10

Drive unit / belt anchor assembly.

10.1 WHAT WE NEED AND WHERE TO FIND IT.

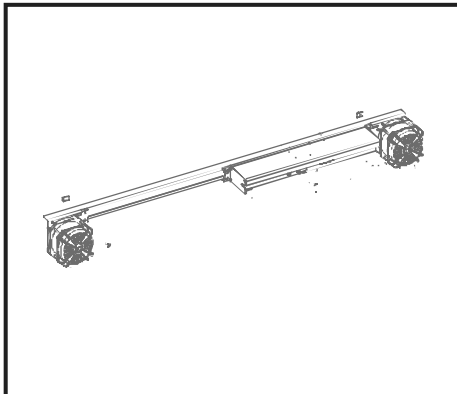

Ref	Description	Location
GIE01	Visio drive unit	Box 1

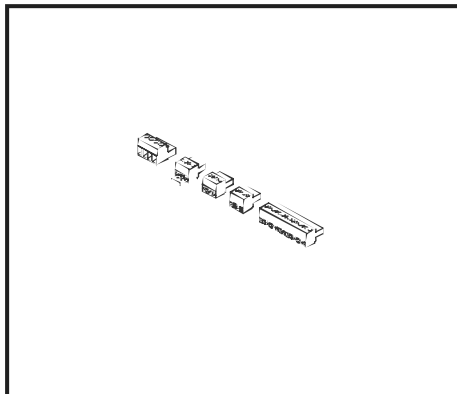

Ref	Description	Location
KCGI01	Visio unit connector pack	Box 1

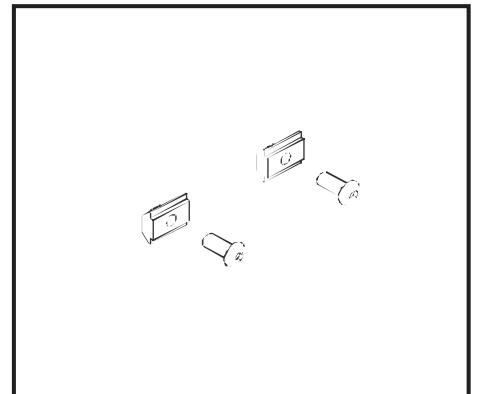

Ref	Description	Location
KTSGMI01	Pack drive unit sec. screws	Box 1

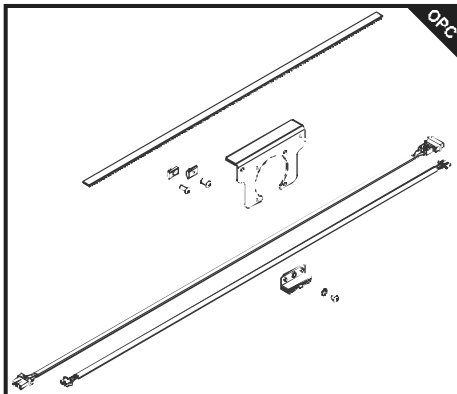

Ref	Description	Location
KEGI01	Visio Kit extension	Box 3

10.2 DRIVE UNIT ASSEMBLY.

10.2.1 Insert nuts in main profile.

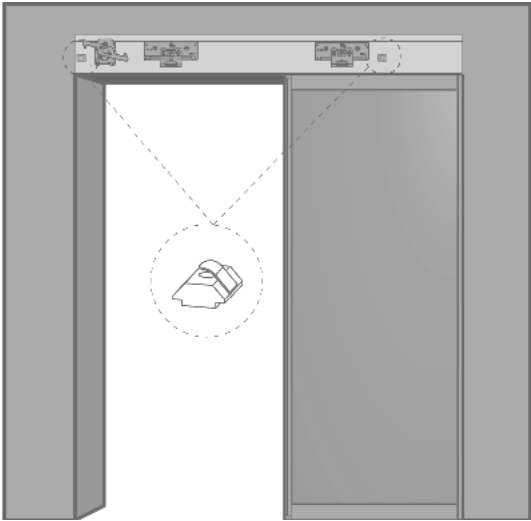

Fig. 10.1

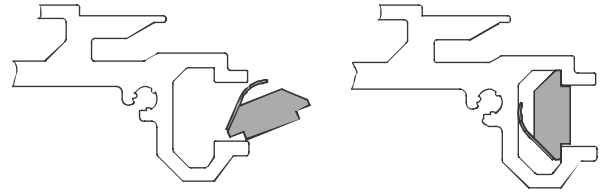

Fig. 10.2

i
 Insert nuts in main profile as shown in the dia-
 Fig. 10.1 Fig. 10.2

10.2.2 LAYOUT OF COMPONENTS PL<=1000

OPENING TO THE RIGHT PL<=1000 →

← OPENING TO THE LEFT PL<=1000

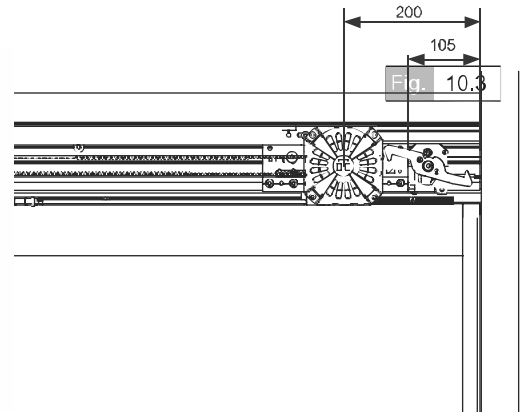
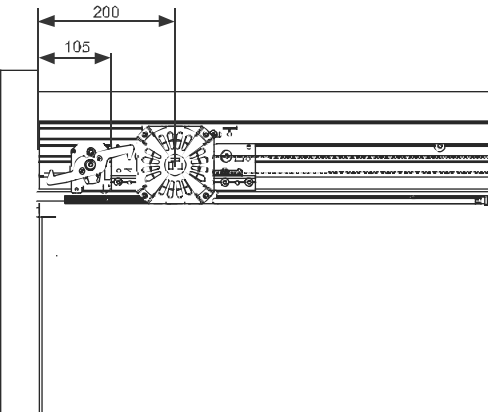

Fig. 10.3

10.2.3 SCREW IN THE DRIVE UNIT

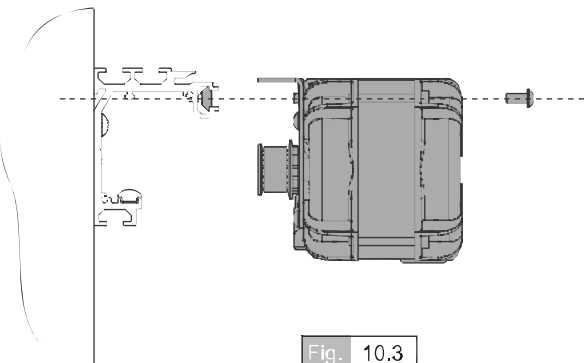

Fig. 10.3

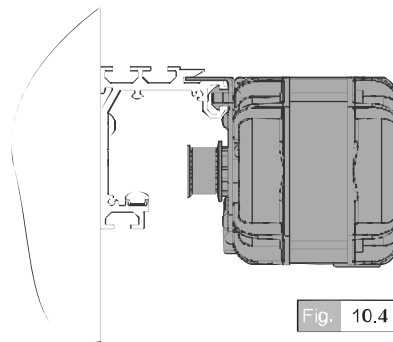

Fig. 10.4

i
 Screw the drive unit to the main profile as shown in the diagrams.
 Fig. 10.3 Fig. 10.4

- | | |
|---------------|--------------|
| Nuts & bolts | Nuts & bolts |
| | |
| Spring Nut M6 | DIN7380 6x14 |

10.2.4 DRIVE UNIT WITH EXTENSION KIT PL>1000 ASSEMBLY

OPENING TO THE RIGHT PL<=1000 →

Fig. 10.5

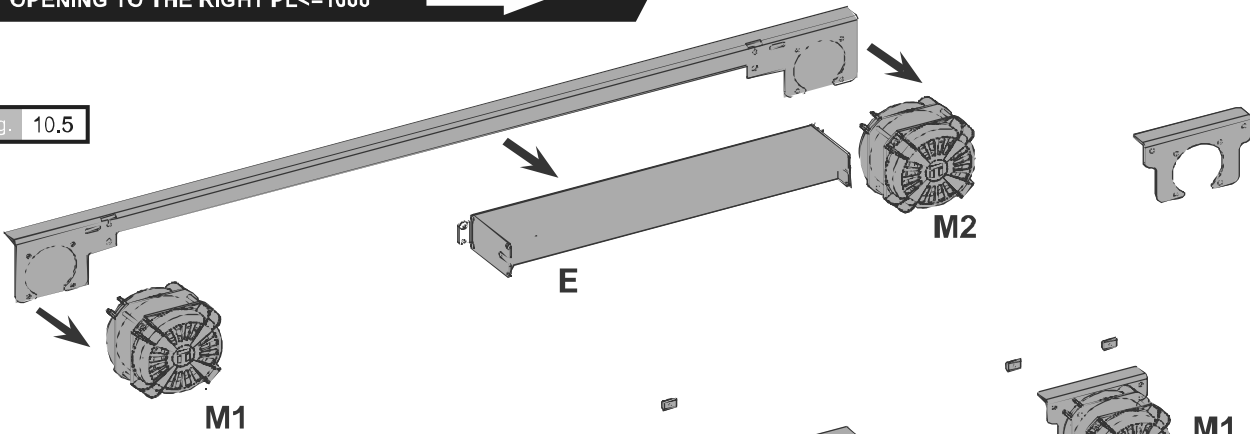
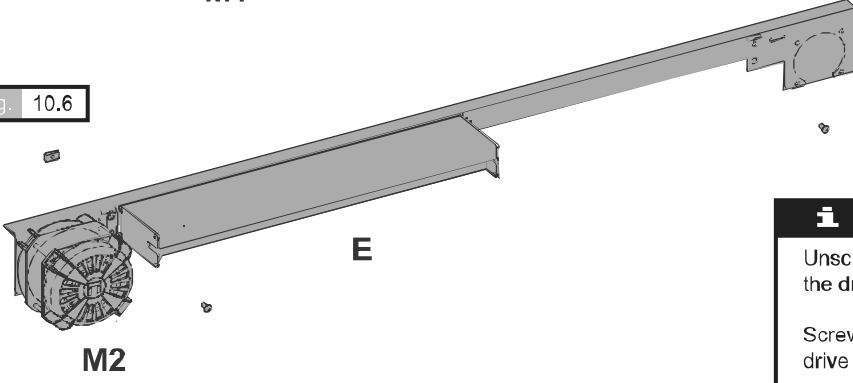

Fig. 10.6



i
 Unscrew motors (M1, M2) and electronics unit (E) from the drive assembly. Fig. 10.5
 Screw M1 onto the extension plate, and M2 and E, in the drive unit plate as illustrated. Fig. 10.6
Note:
 Only carry out this operation where PL > 1000 mm. Where PL < 1000 mm there is no need to disassemble the drive unit.

← OPENING TO THE LEFT PL<=1000

Fig. 10.7

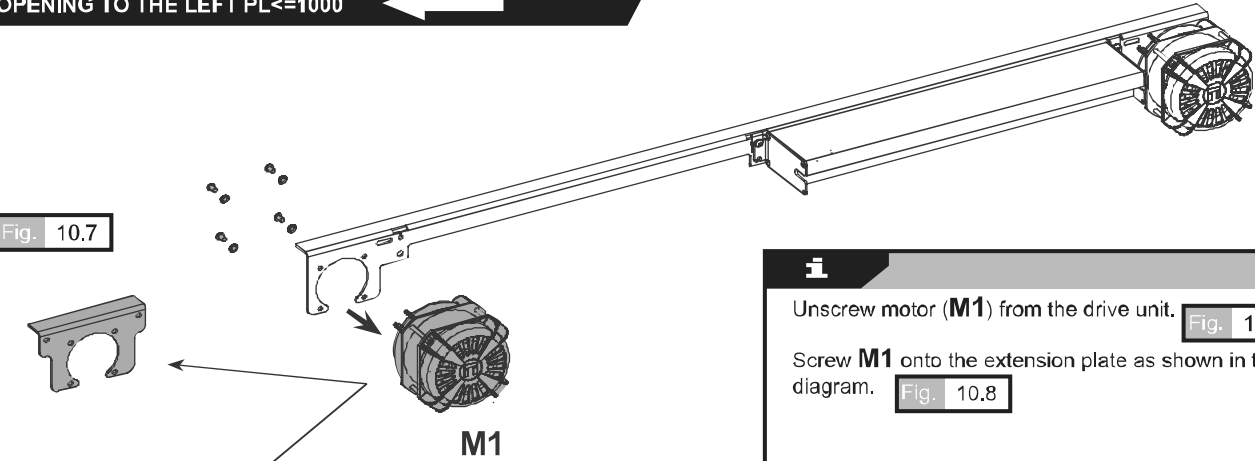
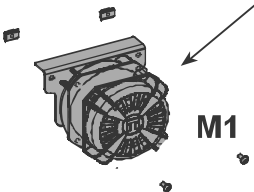

Fig. 10.8



i
 Unscrew motor (M1) from the drive unit. Fig. 10.7
 Screw M1 onto the extension plate as shown in the diagram. Fig. 10.8
Note:
 Only carry out this operation where PL > 1000 mm. Where PL < 1000 mm there is no need to disassemble the drive unit.

10.2.5 LAYOUT OF COMPONENTS PL>1000

OPENING TO THE RIGHT PL<=1000 

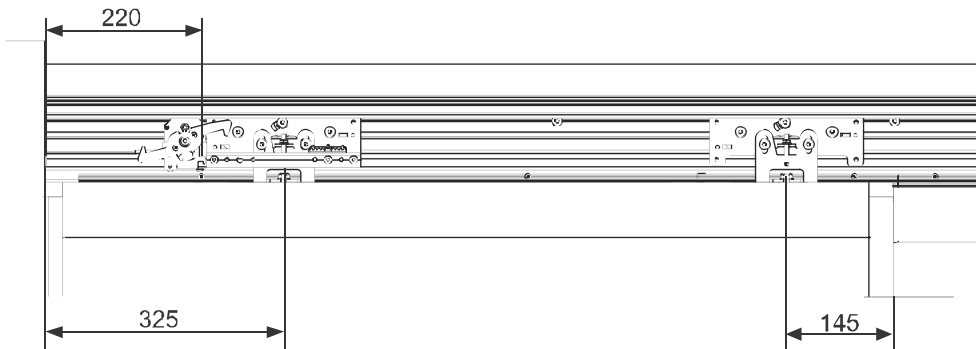

OPENING TO THE LEFT PL<=1000 

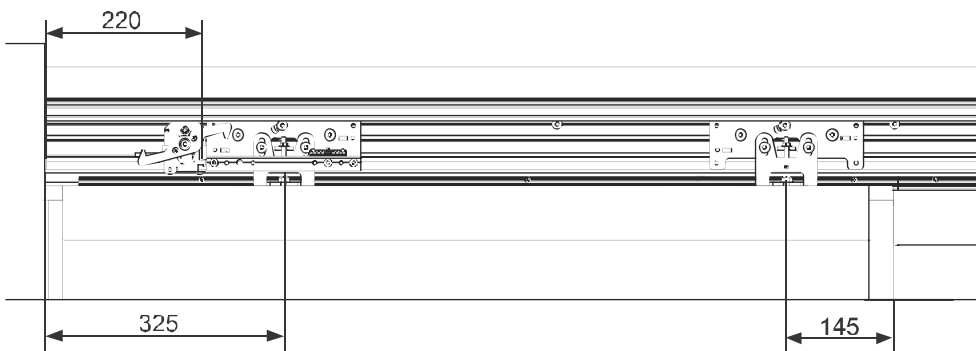

10.2.6 SCREW IN THE DRIVE UNIT



Screw the drive unit to the main profile as shown in the diagrams.

Fig. 10.3

Fig. 10.4

10.2.7 Placement of drive unit.

OPENING TO THE RIGHT PL<=1000 

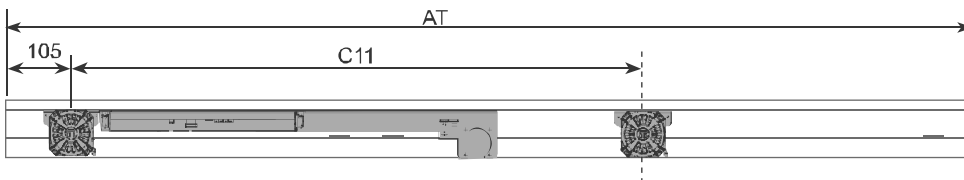

Fig. 10.9

Assembly scheme for opening to the right. C11 according to table fig. 10.15

OPENING TO THE LEFT PL<=1000 

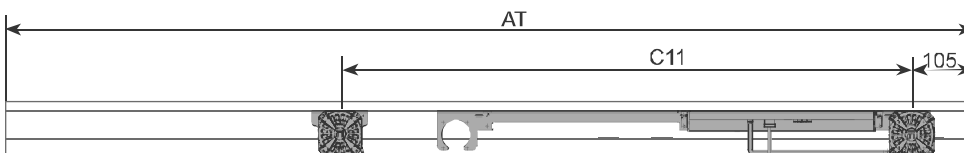

Fig. 10.10

Assembly scheme for opening to the left. C11 according to table fig. 10.15

10.3 BELT ASSEMBLY

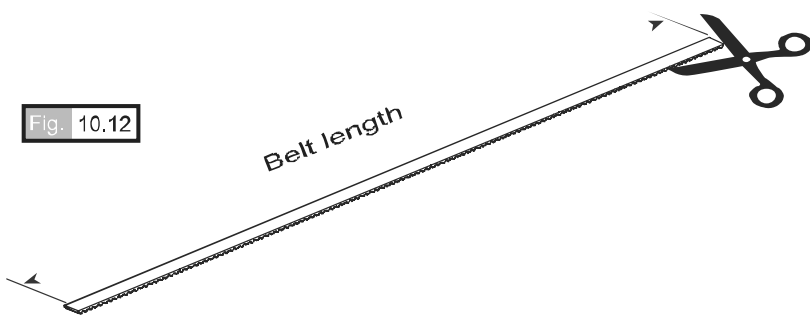

Fig. 10.12

i

Cut the belt as shown in the diagram. **Fig. 10.12**

See table for belt length. **Fig. 10.15**

Place the anchors along the belt as shown in the diagram. **Fig. 10.13**

For C11 length see table. **Fig. 10.15**

Attach anchors to arms as shown in diagram. **Fig. 10.15** **Fig. 10.16**

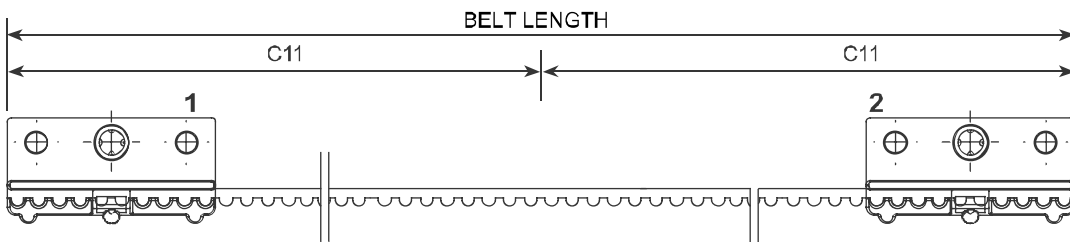
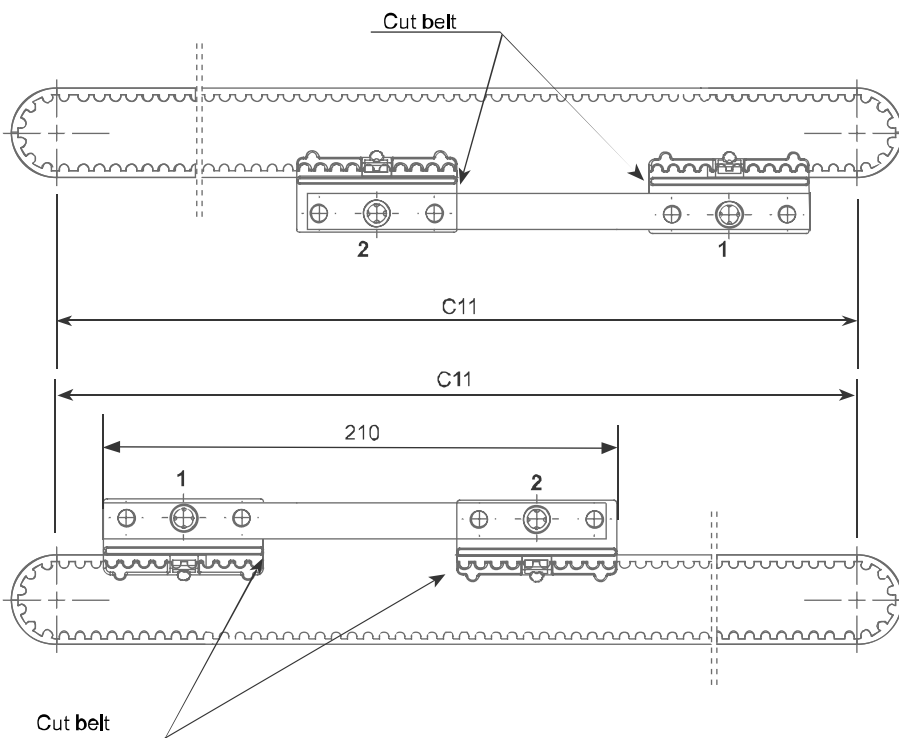

Fig. 10.13

PL	C11	Length of Belt*
1000 < PL < 1250	1635	3350
1250 < PL < 1500	1885	3850
1500 < PL < 1750	2135	4350
1750 < PL < 2050	2435	4950

Fig. 10.15



Drive unit opening to the right.

Fig. 10.16

Fig. 10.16

Drive unit opening to the left.

Visio Lateral 1 Leaf Operator

Assembly f11

Cover assembly

11.1 WHAT WE NEED AND WHERE TO FIND IT.

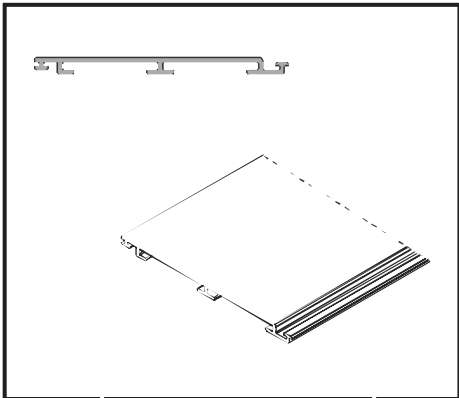

Ref	Description	Location
PACICH	Al.Prof.Visio Plate Horiz. Cover	Box 2

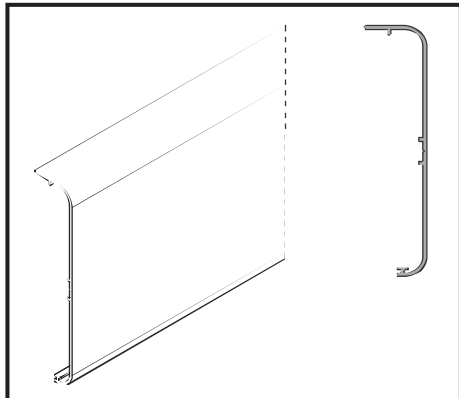

Ref	Description	Location
PACICF	Al.B.Visio Ch. Cover Front 125	Box 2

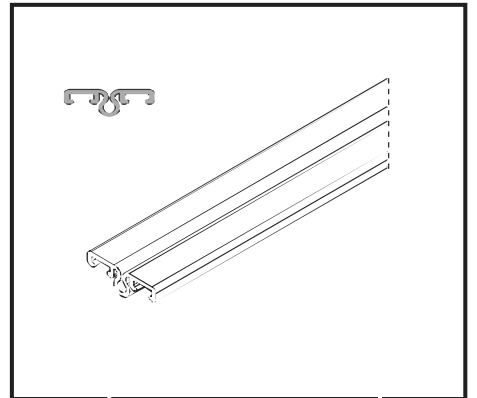

Ref	Description	Location
PPCIBC	PVC B. Visio Plate Cov. hinge	Box 2

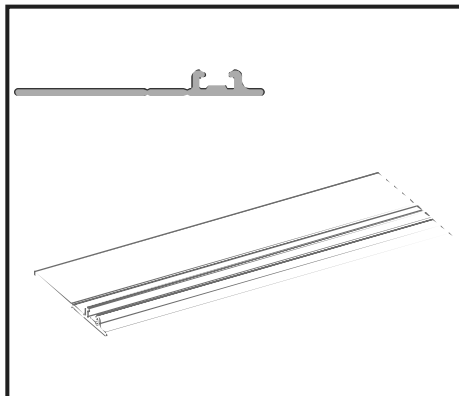

Ref	Description	Location
PPCIPF	PVC B. Visio Ch. woolpile holder	Box 2

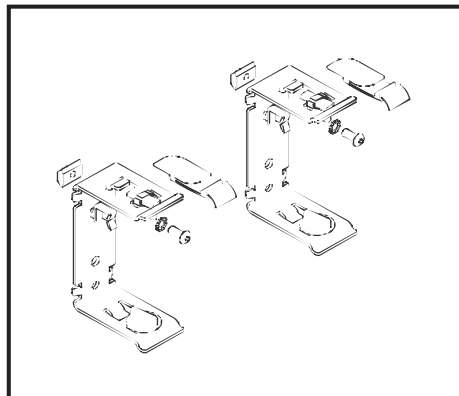

Ref	Description	Location
KSC12501	Box 2Pack Brack. for Cover 125	Box 2

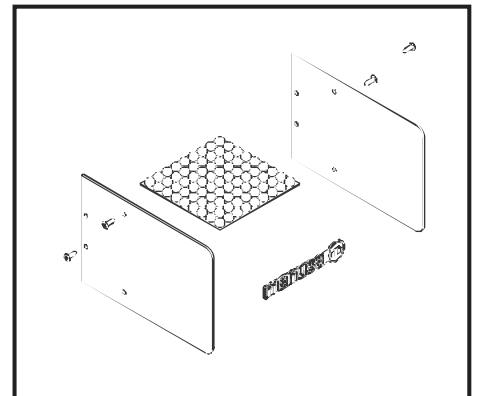

Ref	Description	Location
KTC12501	Pack cover end caps 125	Box 2

11.2 BOTTOM AND FRONT COVER PRE-ASSEMBLY

Fig. 11.1

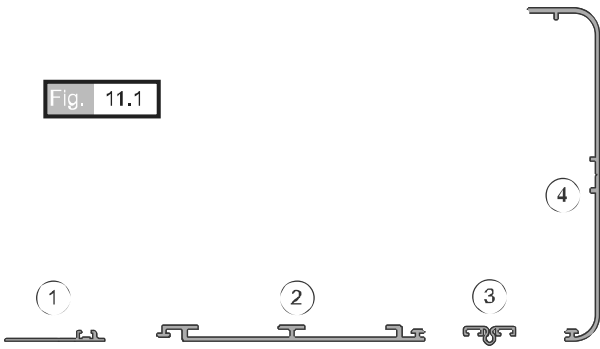

Fig. 11.2

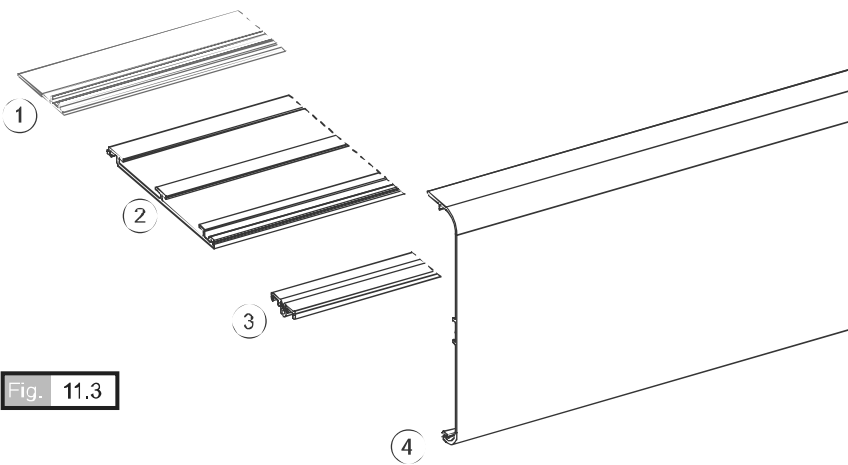
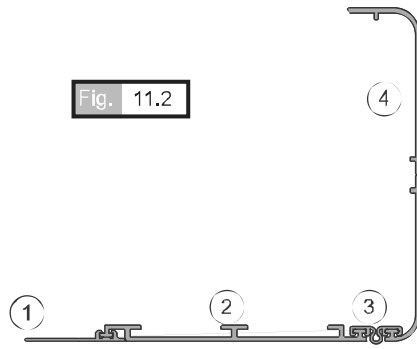

Fig. 11.3

i

Assemble bottom and front cover as shown in diagrams.

Fig. 11.1 Fig. 11.2

11.3 BRACKETS

11.3.1 Insert nuts.

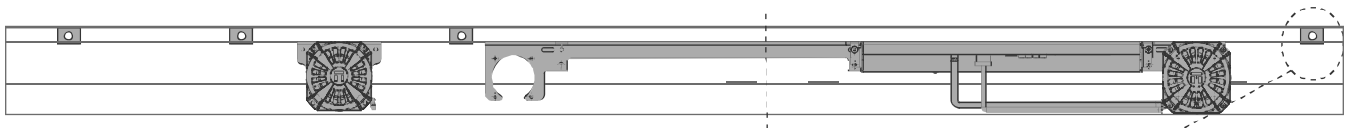
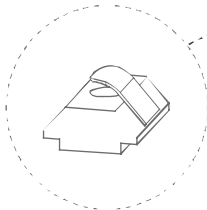
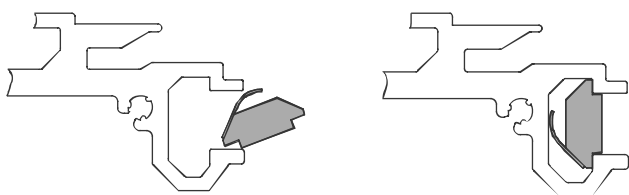



Fig. 11.4

Fig. 11.5



Nuts & bolts



Spring Nut M6

i

Insert nuts in main profile in the positions shown in the diagrams.

Fig. 11.4 Fig. 11.5

11.3.2 Brackets assembly.

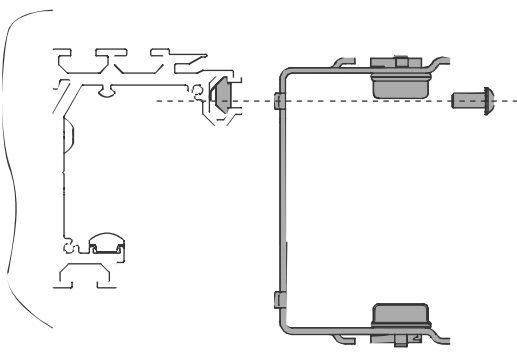

Fig. 11.6

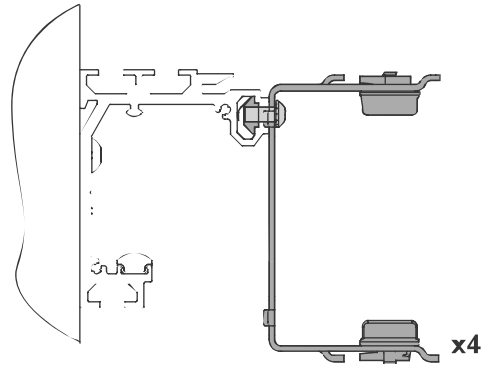
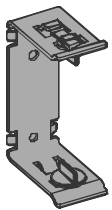

Fig. 11.7



Nuts & bolts	Nuts & bolts	Nuts & bolts
DIN6798 M-6	DIN7380 6x14	Spring Nut M6

i

Mount brackets (x4) onto the main profile as shown in the diagrams.

Fig. 11.6 Fig. 11.7

11.4 COVER ASSEMBLY

11.4.1 Top cover assembly.

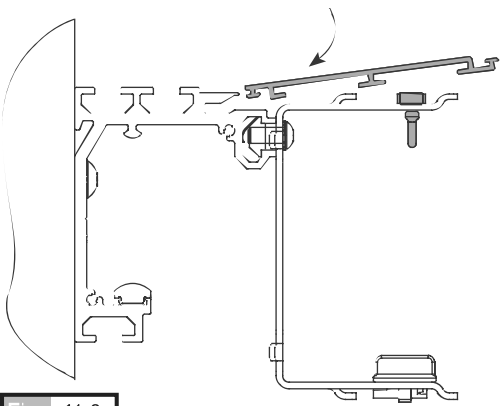

Fig. 11.8

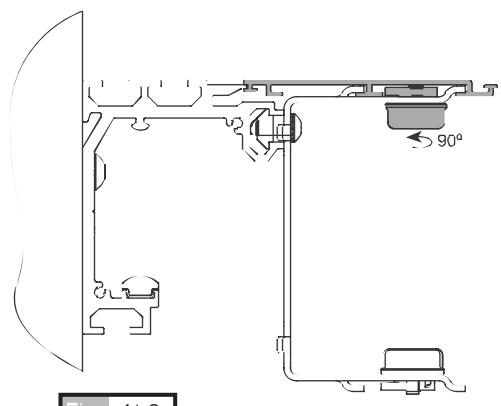

Fig. 11.9

i

Position top cover as shown in the diagram.

Fig. 11.8

Fix (x4) the brackets as shown in the diagram.

Fig. 11.9

11.4.2 Snap-on clip assembly.

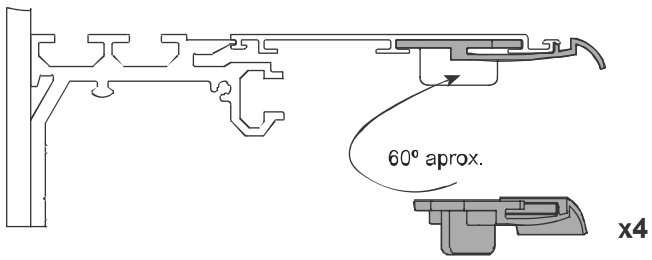

Fig. 11.10

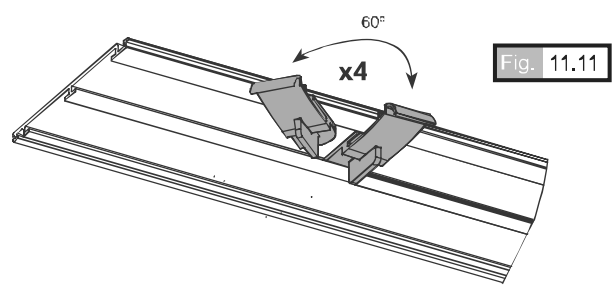

Fig. 11.11

i

Assemble the snap-on clips (x4) to the top element cover as shown in the diagrams.

Fig. 11.10 Fig. 11.11

11.4.3 Bottom and front cover assembly

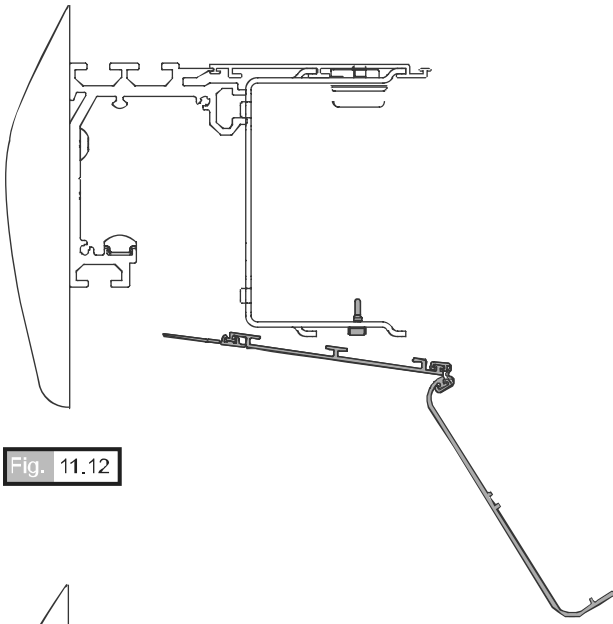

Fig. 11.12

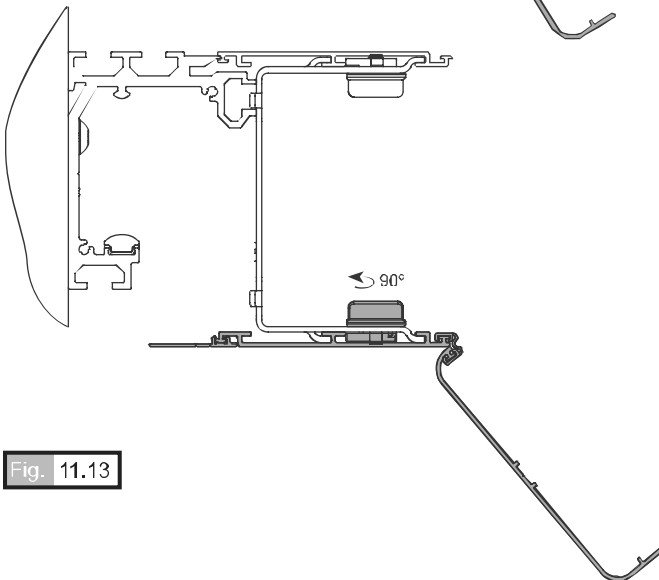

Fig. 11.13

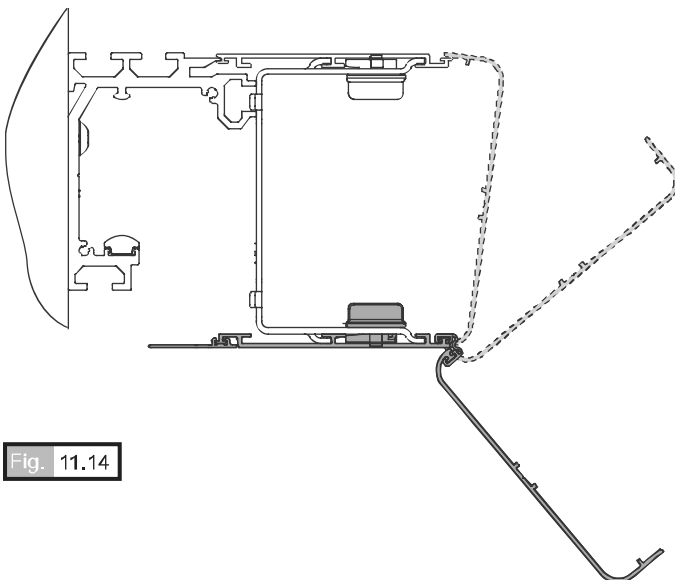

Fig. 11.14



Assemble bottom cover onto brackets as shown in the diagram. Fig. 11.12

Fix bottom cover as shown in the diagram. Fig. 11.13

Close front cover as shown in the diagram. Fig. 11.14

11.4.3 Side caps assembly.

Fig. 11.15

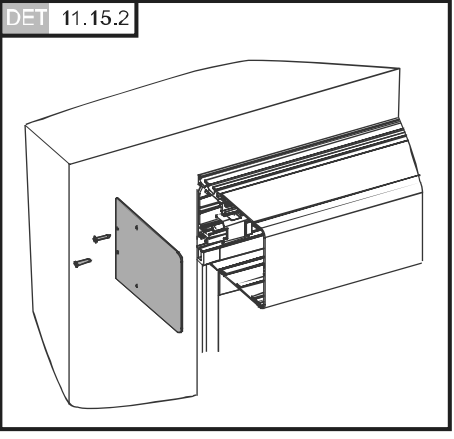
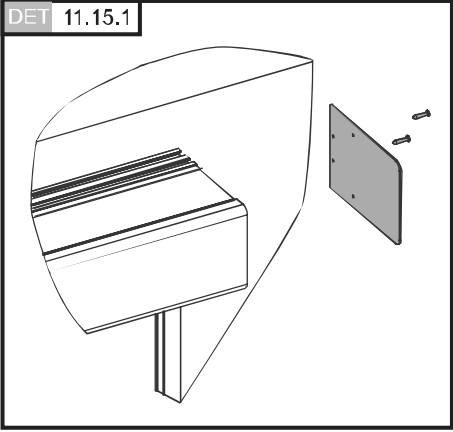
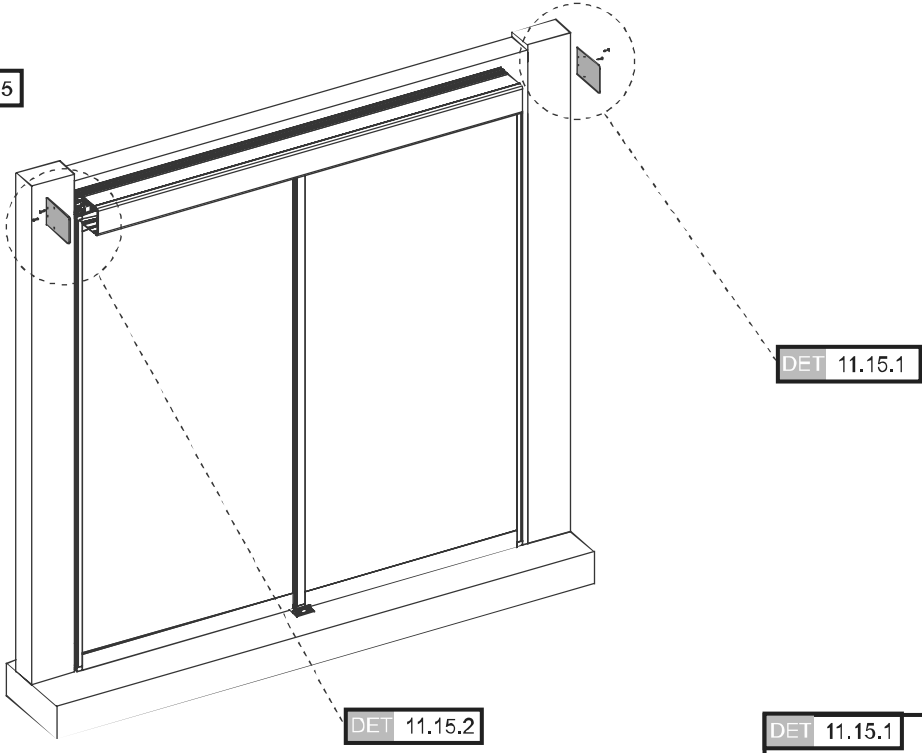

Nuts & bolts

CE-PLUS 4.2X13

Screw end covers to both ends of the cover as shown in the diagrams.

Fig. 11.15 DET 11.15. DET 11.15.



Visio Lateral 1 Leaf Operator

Assembly f12

Manual unlock assembly.

12.1 WHAT WE NEED AND WHERE TO FIND IT.

12.2 REMOVE FRONT AND BOTTOM COVER

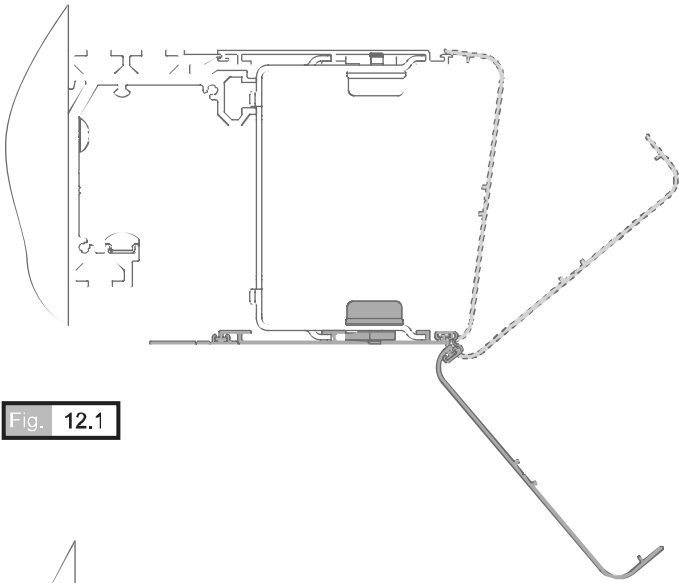

Fig. 12.1

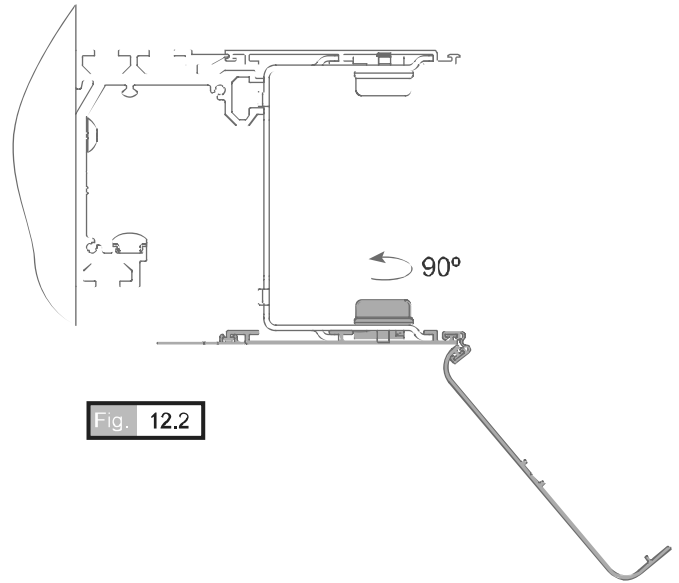

Fig. 12.2

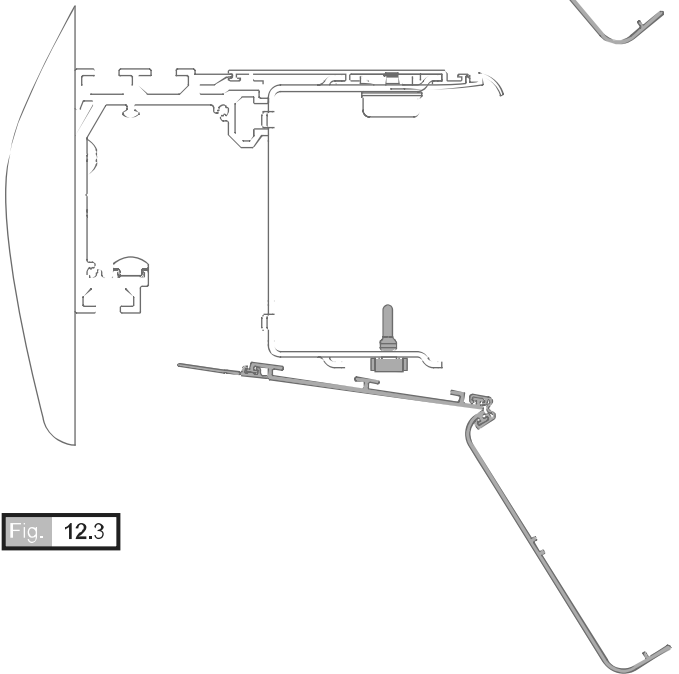

Fig. 12.3

i
 Open front cover. **Fig. 12.1**
 Release the bracket attachments for the bottom cover. **Fig. 12.2**
 Remove the bottom cover and the front cover. **Fig. 12.3**

12.2 REMOVE FRONT AND BOTTOM COVER

OPENING TO THE RIGHT

i
 Drill a hole size $\text{Ø}10.5$ at a distance 30mm from the end of the bottom cover as shown in the diagram. **Fig. 12.4**
 Make the hole in the centre of the bottom cover AT/2 as shown in the diagram. **Fig. 12.5**

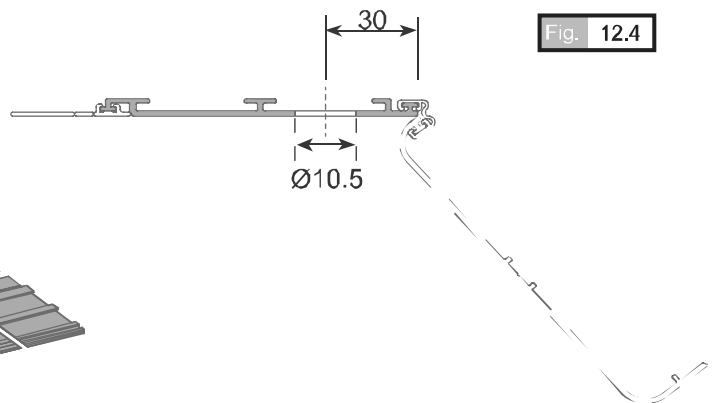

Fig. 12.4

75 for PL<1000
 190 for PL>1000

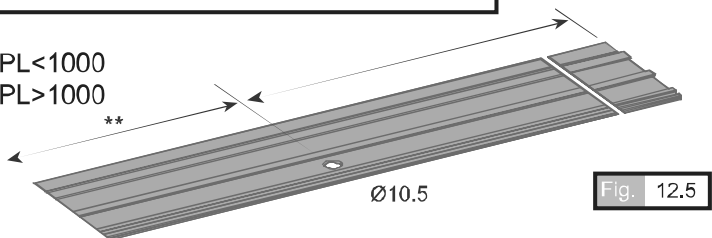
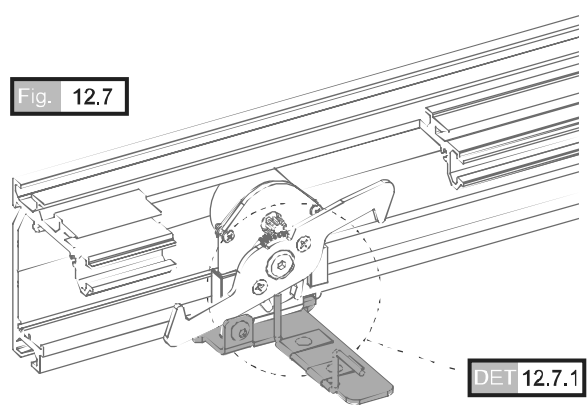
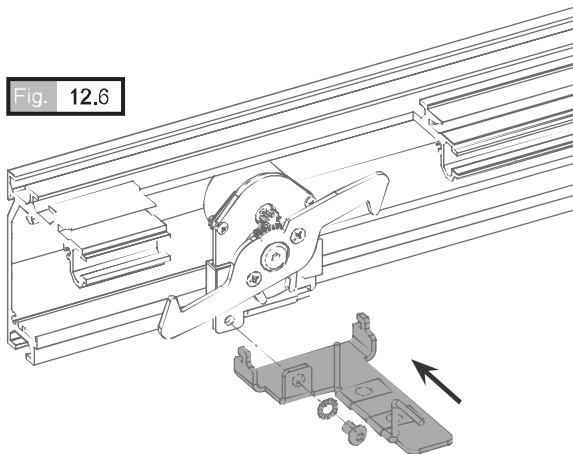



Fig. 12.5

12.4 MANUAL UNLOCK ASSEMBLY.

12.4.1 Lock attachment piece assembly.



Nuts & bolts	Nuts & bolts
	
DIN7380 6x10	DIN6798 M-6



Screw the piece to the lock as shown in the diagram.

Fig. 12.6

Ensure that the actuator is between the two projections as shown in the diagrams.

Fig. 12.7

DET 12.7.1

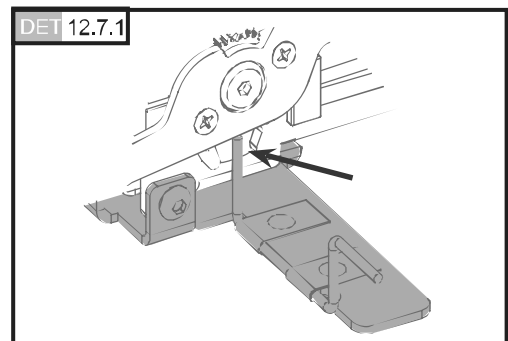

12.4.1 Bottom and front cover assembly

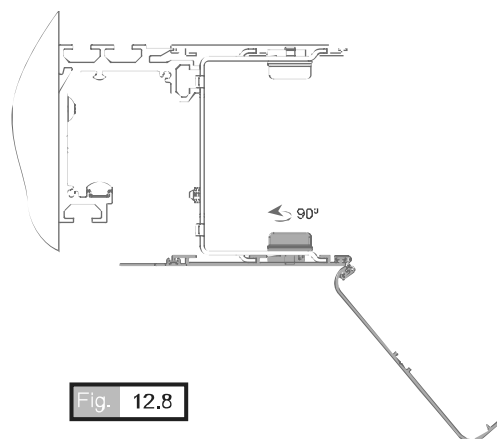
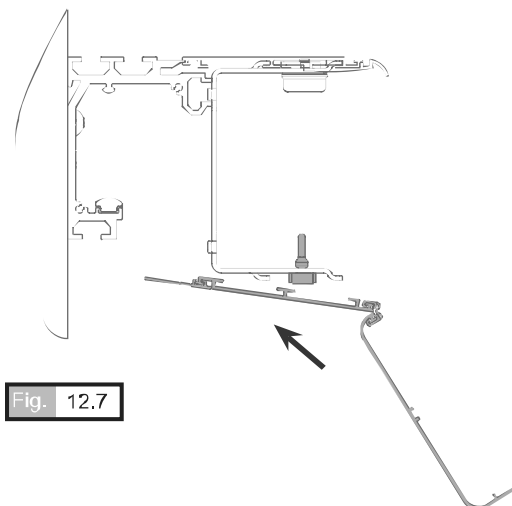

Introduce bottom cover onto brackets as shown in the diagram.

Fig. 12.7

Attach onto brackets (rotate 90°) as shown in the diagram.

Fig. 12.8

12.4.2 Toothed piece assembly

Fig. 12.9

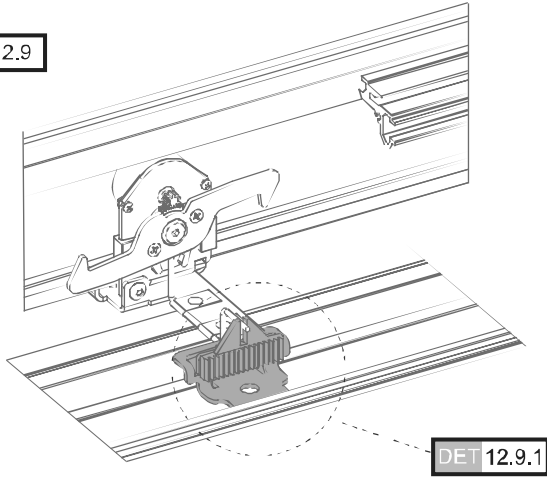

DET 12.9.1

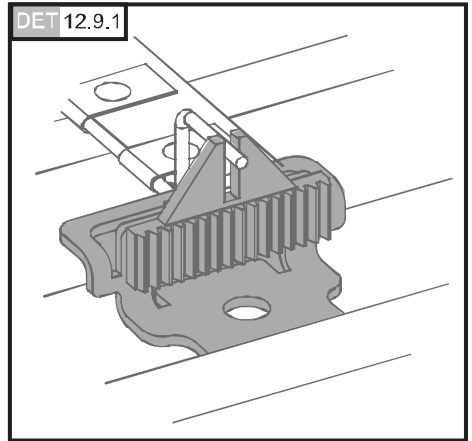
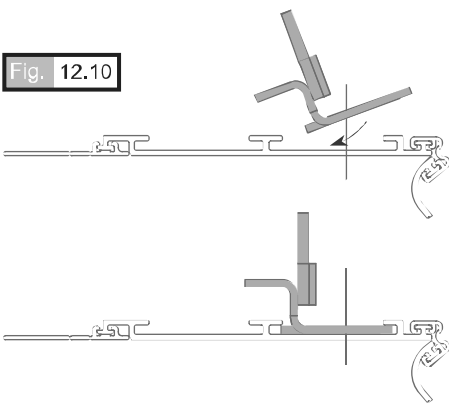

Fig. 12.10



Insert the piece onto the bottom cover as shown in the diagrams. Fig. 12.9 Fig. 12.10

Ensure that the bolt rests in the slot and is centred with respect to the hole in the bottom cover as shown in the diagram. DET 12.9.1

12.4.3 Unlocking actuator assembly.

Fig. 12.11

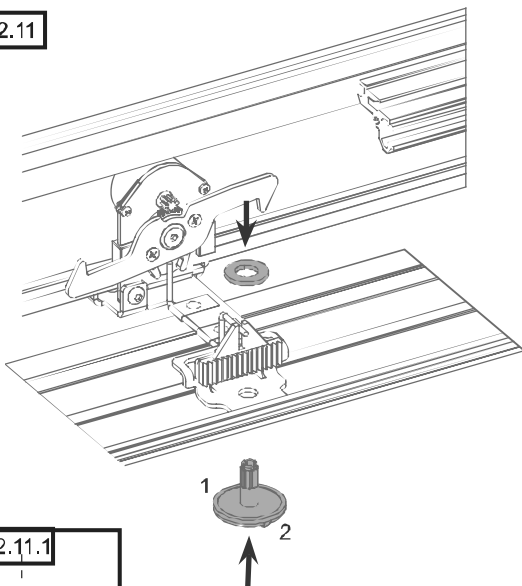

DET 12.11.1

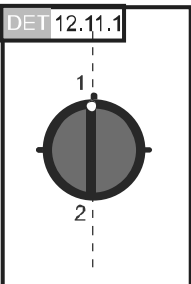
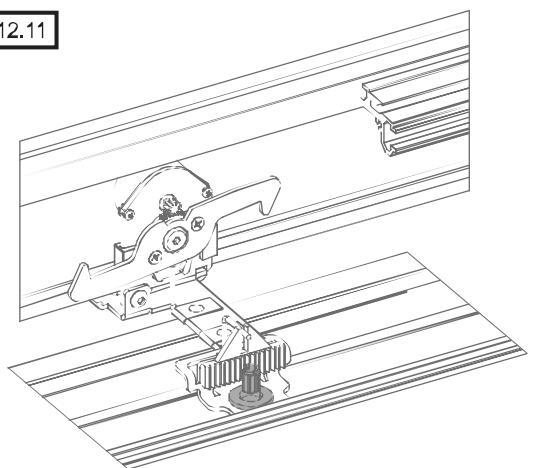

Fig. 12.11



Insert the actuator and securing washer as shown in the diagrams. Fig. 12.11 Fig. 12.11

Ensure that the actuator is oriented as shown in the diagram.

DET 12.11.1

12.4.4 Toothed cylinder assembly

Fig. 12.13

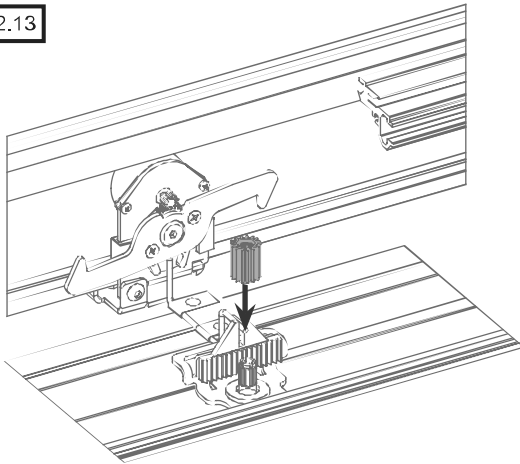
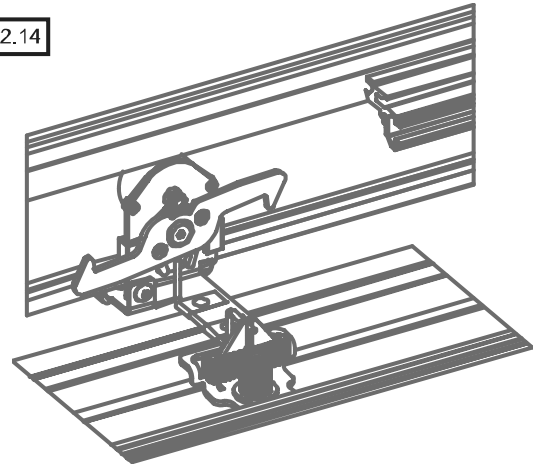

Fig. 12.14



i
 Insert the toothed cylinder as shown in the diagrams.
 Fig. 12.13 Fig. 12.14
 Push it in all the way until it snaps into place.

12.4.4 Operate lock manually.

Fig. 12.15

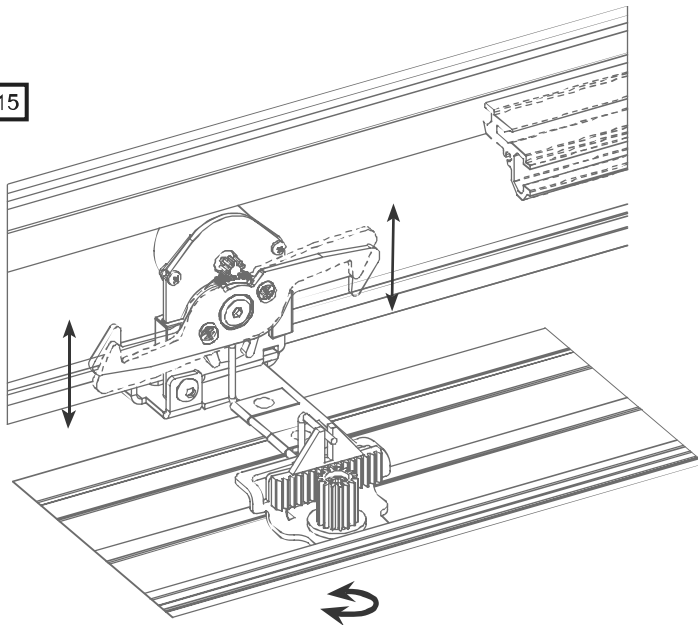

i
 Check that when the unlocking mechanism is operated manually, the lock's bolts open and close as shown in the diagram. Fig. 12.15
 See the operation of the unlocking mechanism as shown in the sequence. Fig. 12.16

Fig. 12.16

To close

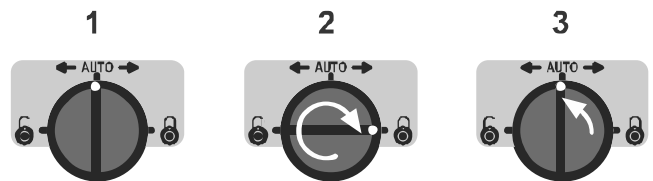

To open

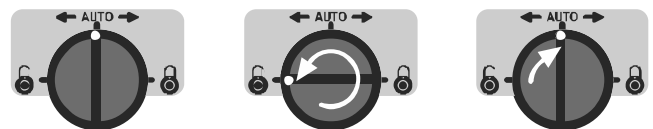

NOTE: *The characteristics indicated in this manual are purely informative, and not in any way contractual.*

The manufacturer reserves the right to make modifications without prior notice.

Last revision: August 2008

manusa 

CENTRAL OFFICES

Edif. TESTA-10, 4º
Avda. Via Augusta, 71-73
08174 Sant Cugat del Vallès
Barcelona - España
Tel. +34 902 321 400

FACTORY

Ctra. Pla de Sta. Maria 235-239
43800 Valls - Tarragona (Spain)
Tel. +34 902 321 700
Fax +34 902 321 750

www.manusa.com