

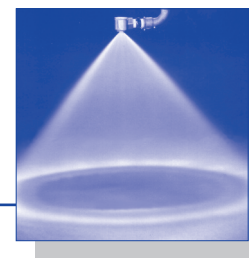

Tangential-flow hollow cone nozzles

Bayonet quick-release system

Series 302



A time-saving alternative to threaded design. Quick and secure assembling. Automatic setting of spray direction.

Applications:

Humidification of air in air washers, dust control, spraying onto filters, foam control.

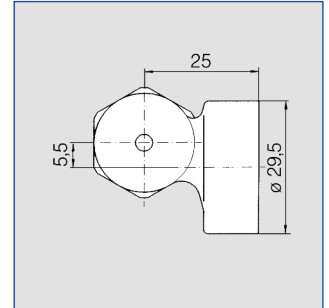
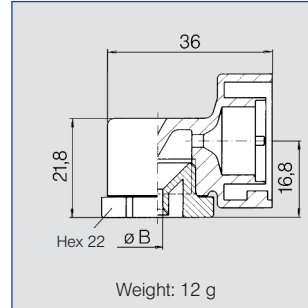

Spray angle	Ordering no.				B \varnothing [mm]	E \varnothing [mm]	\dot{V} [l/min]							Spray diameter D at p = 2 bar	
	Type	Mat. no.		Code			p [bar]								
		51 PA	56 POM				Bayonet- quick-release	0,5	1,0	2,0	3,0	5,0	10,0		
45°	302. 503	○	-	KB	2,05	2,05	0,90	1,27	1,80	0,56	2,20	2,85	4,02	220	560
60°	302. 464	-	○	KB	1,95	1,95	0,70	0,99	1,40	0,43	1,71	2,21	3,13	300	560
80°	302. 545	-	○	KB	2,30	2,30	1,12	1,58	2,24	0,69	2,74	3,54	5,01	400	700
90°	302. 326	○	○	KB	1,05	1,05	0,20	0,28	0,40	0,12	0,49	0,63	0,89	400	700
	302. 406	○	○	KB	1,55	1,55	0,50	0,71	1,00	0,31	1,22	1,58	2,24	400	880
	302. 486	○	-	KB	2,10	2,10	0,80	1,13	1,60	0,50	1,96	2,53	3,58	400	880
	302. 606	○	-	KB	5,00	3,20	1,58	2,23	3,15	0,98	3,86	4,98	7,04	450	880
130°	302. 368	-	○	KB	1,30	1,30	0,31	0,45	0,63	0,20	0,77	1,00	1,41	700	1380
	302. 408	○	○	KB	2,00	2,00	0,50	0,71	1,00	0,31	1,22	1,58	2,24	700	1380
	302. 468	○	-	KB	2,40	2,40	0,70	0,99	1,40	0,43	1,71	2,21	3,13	700	1380
	302. 488	○	-	KB	2,75	2,75	0,80	1,13	1,60	0,50	1,96	2,53	3,58	700	1380

B = bore diameter · E = narrowest free cross section

Example Type + Material no. + Code = Ordering no.
for ordering: 302. 464 + 56 + KB = 302. 464. 56. KB

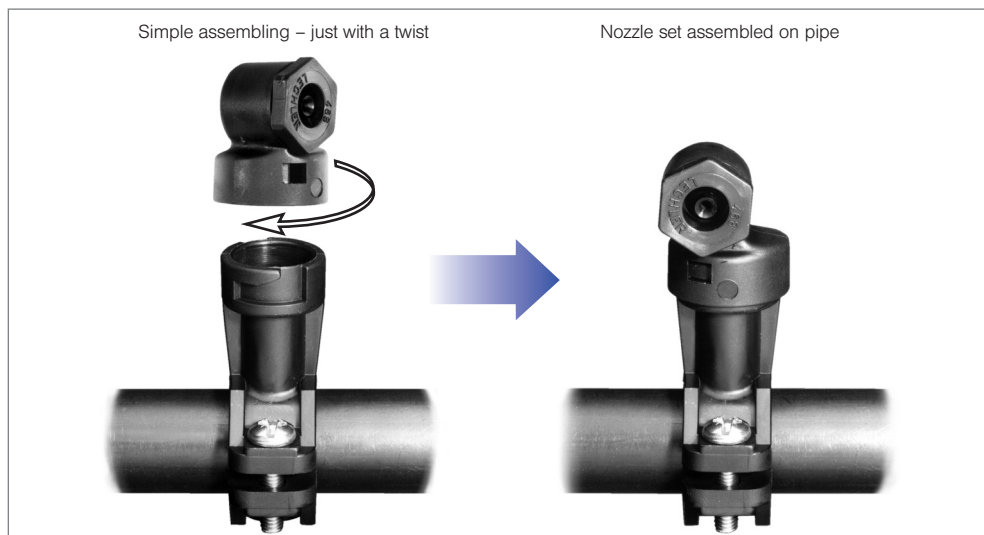

The folded page at the end of the catalogue will give you a survey on the various assembly possibilities. For complete assembly accessories, please refer to »Accessories«.