



Flat fan nozzles

Series 610



Compact design, suitable for narrow installation conditions. Stable spray angle. Uniform parabolic distribution of liquid.

Applications:
Cleaning installations, cooling headers, spray pipes.

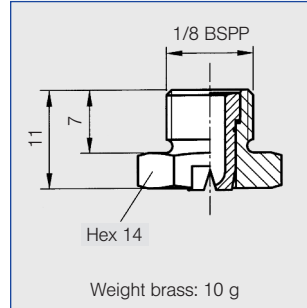

Spray angle	Ordering no.		A Ø [mm]	E Ø [mm]	V̇ [l/min]								Spray width B at p = 2 bar		
	Type	Mat.-no.			p [bar]								 H = 250 mm H = 500 mm		
		16 1.4305/303 SS			30 Brass	0,5	1,0	2,0	[US gal./min] at 40 psi	3,0	5,0	10,0			
20°	610. 301	○	○	0,70	0,60	0,16*	0,23*	0,32	0,10	0,39	0,51	0,72	65	125	
	610. 361	○	○	1,00	0,80	0,31*	0,44*	0,63	0,20	0,77	1,00	1,40	65	125	
	610. 441	○	○	1,35	1,10	0,62*	0,88	1,25	0,39	1,53	1,98	2,80	65	125	
	610. 481	○	○	1,50	1,20	0,80*	1,13	1,60	0,50	1,96	2,53	3,58	65	125	
30°	610. 302	○	○	0,70	0,50	0,16*	0,23*	0,32	0,10	0,39	0,51	0,72	115	230	
	610. 362	○	○	1,00	0,70	0,31*	0,44*	0,63	0,20	0,77	1,00	1,40	115	230	
	610. 402	○	○	1,20	0,90	0,50*	0,71	1,00	0,31	1,23	1,58	2,24	115	230	
	610. 482	○	○	1,50	1,10	0,80*	1,13	1,60	0,50	1,96	2,53	3,58	115	230	
	610. 562	○	○	2,00	1,50	1,25	1,77	2,50	0,78	3,06	3,95	5,59	115	230	
45°	610. 303	○	○	0,70	0,50	0,16*	0,23*	0,32	0,10	0,39	0,51	0,72	185	340	
	610. 363	○	○	1,00	0,60	0,31*	0,44*	0,63	0,20	0,77	1,00	1,40	185	340	
	610. 403	○	○	1,20	0,90	0,50*	0,71	1,00	0,31	1,23	1,58	2,24	185	340	
	610. 483	○	○	1,50	1,10	0,80*	1,13	1,60	0,50	1,96	2,53	3,58	185	340	
	610. 563	○	○	2,00	1,40	1,25	1,77	2,50	0,78	3,06	3,95	5,59	185	340	
	610. 643	○	○	2,50	1,80	2,00	2,83	4,00	1,24	4,90	6,33	8,94	185	340	
60°	610. 304	○	○	0,70	0,40	0,16*	0,23*	0,32	0,10	0,39	0,51	0,72	275	525	
	610. 334	○	○	0,90	0,50	0,22*	0,32*	0,45	0,14	0,55	0,71	1,01	275	525	
	610. 364	○	○	1,00	0,60	0,31*	0,44*	0,63	0,20	0,77	1,00	1,40	275	525	
	610. 404	○	○	1,20	0,80	0,50*	0,71	1,00	0,31	1,23	1,58	2,24	275	525	
	610. 444	○	○	1,35	0,90	0,62*	0,88	1,25	0,39	1,53	1,98	2,80	280	530	
	610. 484	○	○	1,50	1,00	0,80*	1,13	1,60	0,50	1,96	2,53	3,58	280	530	
	610. 514	○	○	1,65	1,10	0,95*	1,34	1,90	0,59	2,33	3,00	4,25	280	530	
	610. 564	○	○	2,00	1,30	1,25	1,77	2,50	0,78	3,06	3,95	5,59	280	530	
	610. 604	○	○	2,20	1,50	1,58	2,23	3,15	0,98	3,86	4,98	7,04	280	530	
75°	610. 145	○	○	0,16	0,30	-	0,04*	0,05	0,02	0,06	0,08	0,11	285	550	
	610. 165	○	○	0,20	0,34	-	0,05*	0,07	0,02	0,08	0,10	0,15	285	555	
	610. 185	○	○	0,35	0,20	-	0,06*	0,08	0,11	0,10	0,13	0,18	290	560	
	610. 215	○	○	0,40	0,20	-	0,08*	0,11	0,03	0,14	0,18	0,25	290	560	
	610. 245	○	○	0,50	0,30	-	0,12*	0,16*	0,05	0,20	0,26	0,36	290	560	
	610. 275	○	○	0,60	0,30	0,11*	0,16*	0,22	0,07	0,27	0,35	0,49	290	560	

A = Equivalent bore diameter · E = narrowest free cross section
 *Differing spray pattern
 Subject to technical modifications.

Continued on next page.

The folded page at the end of the catalogue will give you a survey on the various assembly possibilities. For complete assembly accessories, please refer to »Accessories«.

Example	Type	+	Material no.	=	Ordering no.
for ordering:	610. 301	+	16	=	610. 301. 16

Conversion formula for the above series: $\dot{V}_2 = \dot{V}_1 \cdot \sqrt{\frac{p_2}{p_1}}$

