

SERIE PR90H

PROGRAMMABLE INCREMENTAL HOLLOW SHAFT ENCODER FOR INDUSTRIAL APPLICATIONS



Programmable incremental optical encoder from 1 to 65.536 pulses per rotation



Programmable via USB, without an additional programming box



Programmable without powering up the encoder



Multi-voltage 5...30 VDC Automatic power voltage recognition



0° to 360° reference signal position



Optical Encoder



Incremental Encoder



Programmable Encoder



High shaft load capacity



Vibration and shock resistant



IP65



Express Delivery

- External diameter 58 mm
- Hollow shaft \varnothing 10, 12, 14 or 15 mm
- Protection class IP65 according to DIN EN 60529
- Connection by cable (other cable length available) or industrial connector M12 or M23

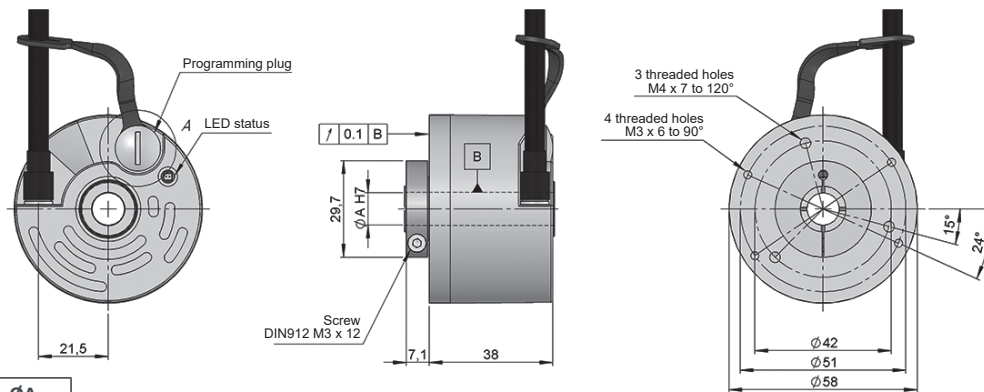
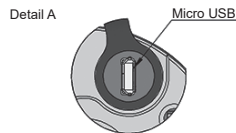

| HOLLOW SHAFT | $\varnothing A$ |
|--------------|-----------------|
| 1 | 10 mm |
| 2 | 12 mm |
| 3 | 14 mm |
| 4 | 15 mm |

Drawing hollow shaft type 1, mechanical option type 2, connection type 1

REFERENCE

Reference example: PR90H-21C1C-C

| Serie | Mechanical option | Hollow shaft | Output signals | Connection | Power Supply / Electronic output | Pulses number | Special customer |
|---------|--------------------------|--|--|--|--|-------------------------------------|---|
| PR90H - | <input type="checkbox"/> | <input type="checkbox"/> | <input checked="" type="checkbox"/> | <input type="checkbox"/> | <input checked="" type="checkbox"/> | <input checked="" type="checkbox"/> | <input type="checkbox"/> <input type="checkbox"/> <input type="checkbox"/> <input type="checkbox"/> |
| | 2. Frontal clamp | 1. \varnothing 10 mm 2. \varnothing 12 mm 3. \varnothing 14 mm 4. \varnothing 15 mm | C. A \tilde{A} +B \tilde{B} +0 \tilde{O} CONFIGURABLE • CW / CCW • Z 90° and 180° • Z position of 0...360° | 1. Helicoidal cable 2. Radial 90.9508 M12 8p CCW 3. Radial 90.9512 M23 12p CCW | C. 5...30 VDC / HTL - TTL CONFIGURABLE • Electronic output HTL / TTL | C. 1...65536 CONFIGURABLE | |

Order your reference
Step file 3D

info@encoderhohner.com
service available in 24 h

Female connector and the required anti-rotation system are not included in the reference. All options available in the sections "CONNECTION DIMENSIONS" and "ANTI-ROTATION SYSTEMS DIMENSIONS", upon request.



SERIE PR90H

PROGRAMMABLE INCREMENTAL HOLLOW SHAFT ENCODER FOR INDUSTRIAL APPLICATIONS

MECHANICAL SPECIFICATIONS

| | |
|--|---|
| Materials | Cover: Aluminium Housing: Aluminium Shaft: Stainless Steel |
| Bearings | Ballraces |
| Bearings lifetime | 1x10 ¹⁰ rev. |
| Housing fixing | Flexible anti-rotation system (different models available) |
| Permitted misalignment (Flexible flange) | ±0.05 mm axial, ±0.1 mm radial |
| Shaft fixing | Front clamp |
| Hollow shaft diameter | 10, 12, 14 or 15 mm |
| Maximum number of revolutions permitted mechanically | 6000 rpm |
| Protection against dust and splashes according to DIN EN 60529 | IP65 |
| Rotor inertia moment | 60 gcm ² |
| Starting torque at 20°C (68°F) | ≤ 0,02 Nm |
| Maximum load permitted on axial shaft | 40 N |
| Maximum load permitted on radial shaft | 80 N |
| Weight aprox. | 0,5 Kg |
| Operating temperature range | -20°C to +80°C |
| Vibration according to DIN EN 60068-2-6 | 100 m/s ² (10Hz...2000Hz) |
| Shock according to DIN EN 60068-2-27 | 1000 m/s ² (6ms) |
| Maximum pulses per turn | 65.536 |
| Connection | 2 meters cable or industrial connector M12 or M23 (other cable lengths available on order) Female connector not included |

OUTPUT SIGNALS

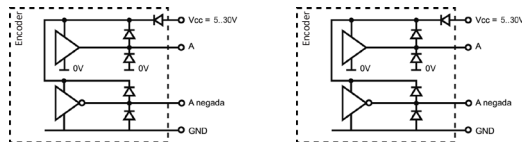

| OUTPUT CIRCUIT | TTL | HTL |
|--------------------------------|-------------------------------|-------------------------------|
| Reference code | C | C |
| Power supply | 5...30 VDC | 5...30 VDC |
| Consumption* | Typical: 45 mA Max: 150 mA | Typical: 45 mA Max: 150 mA |
| Max. load capability / channel | ±20 mA | ±20 mA |
| Length of cable allowed | 1200 m | 1200 m |
| “Low” signal level | VOL < 0.5 VDC | VOL < 2.5 VDC |
| “High” signal level | VOH > 2.5 VDC | VOH > VCC – 1.5 VDC |
| Frequency | 900 kHz | 900 kHz |
| Short circuit protection | Yes | Yes |
| Protection polarity inversion | Yes | Yes |

Configurable CW - Channel A leads (90° electric) channel B, view from the shaft, shaft rotating clockwise
Configurable CCW - Channel B leads (90° electric) channel A, view from the shaft, shaft rotating clockwise

(*) Peak current of 400mA (1ms) at start-up of the encoder.

SERIE PR90H

PROGRAMMABLE INCREMENTAL HOLLOW SHAFT ENCODER FOR INDUSTRIAL APPLICATIONS

CONNECTION



| | 95.0008011 Cable 4x2x0,14 | 90.9508 M12 8p CCW | 90.9512 M23 12p CCW |
|---------------|---------------------------------|--------------------------|---------------------------|
| GND | Black | 7 | 10 |
| VCC | Red | 8 | 12 |
| A | Yellow | 2 | 5 |
| B | Green | 4 | 8 |
| \tilde{A} | Brown | 1 | 6 |
| \tilde{B} | Blue | 3 | 1 |
| 0 (reference) | Grey | 6 | 3 |
| $\tilde{0}$ | Orange | 5 | 4 |

Shield connected to the housing

CONNECTION PC



90.9452
Cable uUSB/USB

(*) The connection cable uUSB / USB is not included in the reference.

Available in the section "ACCESSORIES".

PROGRAMMING DETAILS

LED status:

● *green intermittent indicator:*
Communication between devices

● *red indicator:*
Error detection (overload, low power, optical failure, communications failure, humidity...) See type of error in the programming software

Configuration options:

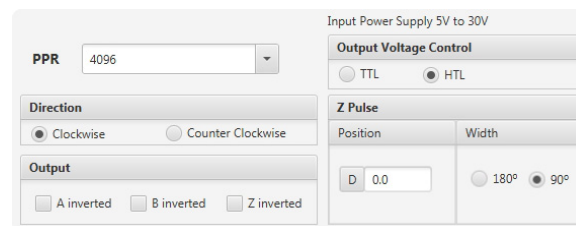

Factory configuration:

- Pulses: 4096 ppr
- Output: HTL
- Direction: Clockwise (CW)
- Position (Z pulse): 0°
- Width (Index, Z, 0): 90°

Download the software and programming manual from: www.encoderhohner.com/pr90/

CONNECTION DIMENSIONS

Female connector not included

Connection 2
Radial 90.9508

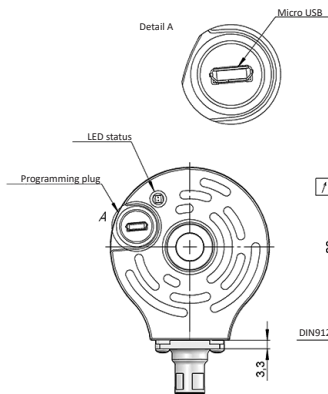

90.9508

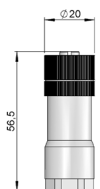

90.9508
M12 8p
male panel
counter clockwise

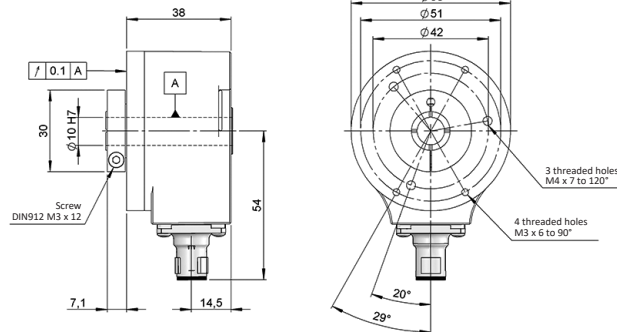

SERIE PR90H

PROGRAMMABLE INCREMENTAL HOLLOW SHAFT ENCODER FOR INDUSTRIAL APPLICATIONS

Connection 3
Radial 90.9512

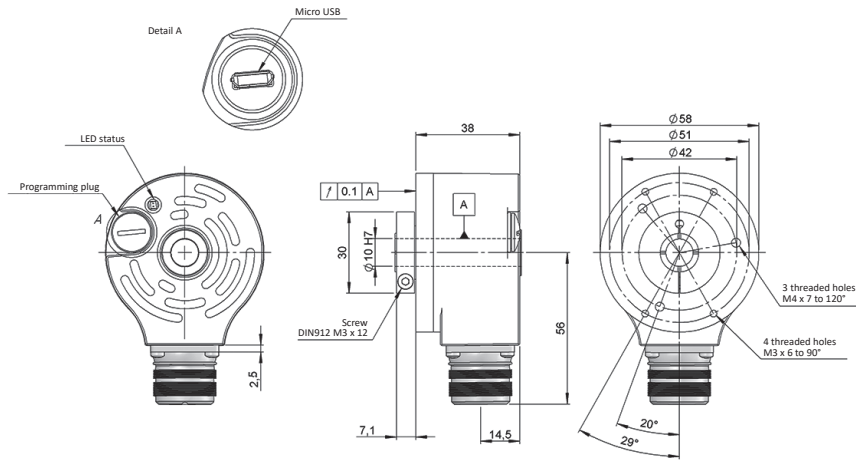

90.9512

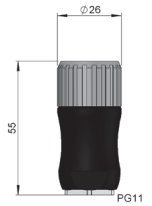

90.9512
M23 12p
male panel
counter clockwise

ANTI-ROTATION SYSTEMS DIMENSIONS

Flexible flange
90.1014

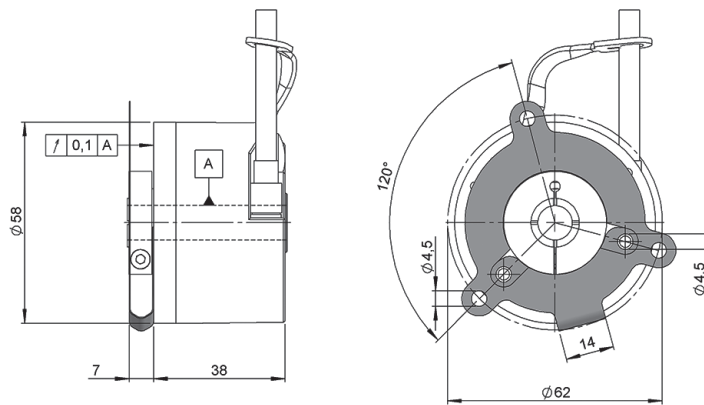

90.1014



Flexible flange
90.1018

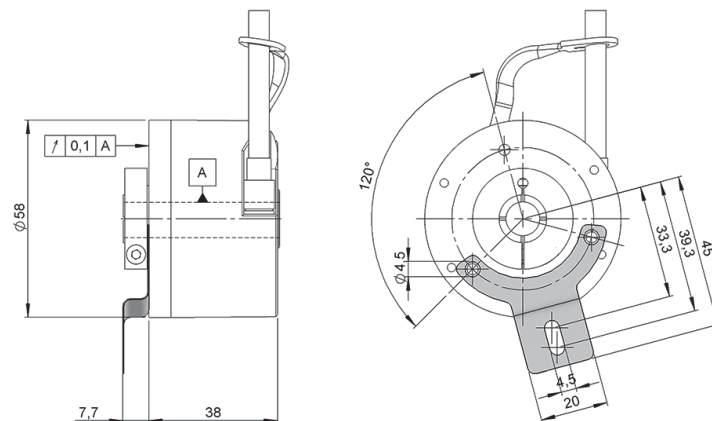

90.1018



SERIE PR90H

PROGRAMMABLE INCREMENTAL HOLLOW SHAFT ENCODER FOR INDUSTRIAL APPLICATIONS

Flexible flange
90.1020

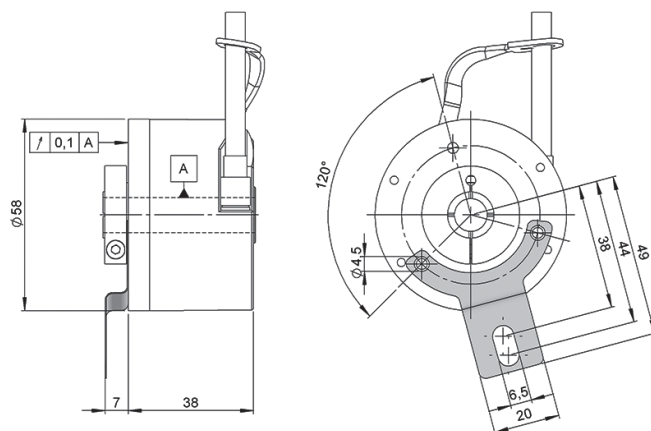

90.1020



Flexible flange
90.1024

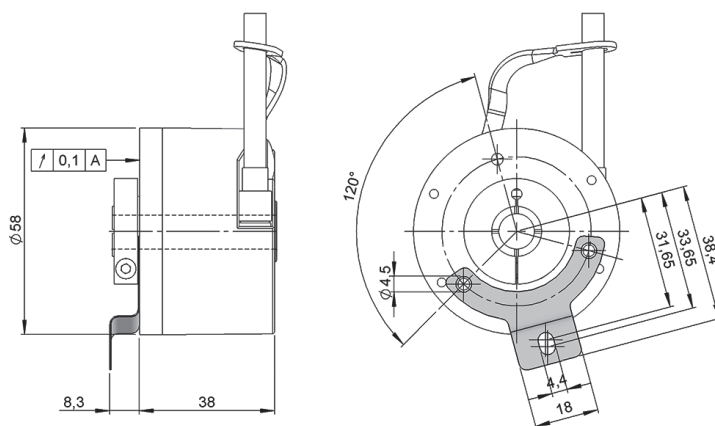

90.1024



Flexible flange
90.1027

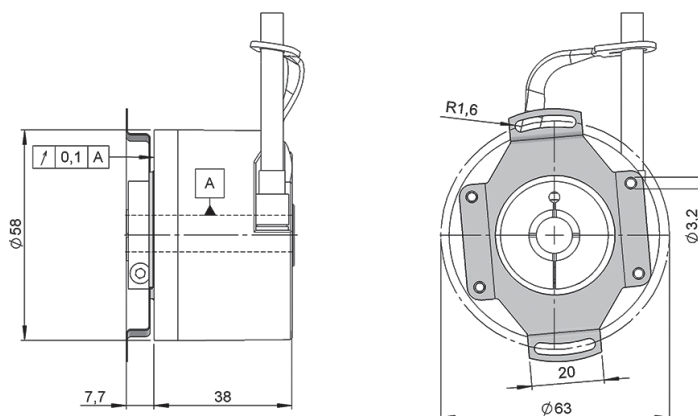

90.1027

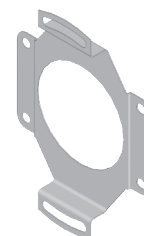

SERIE PR90H

PROGRAMMABLE INCREMENTAL HOLLOW SHAFT ENCODER FOR INDUSTRIAL APPLICATIONS

Flexible flange
90.1075

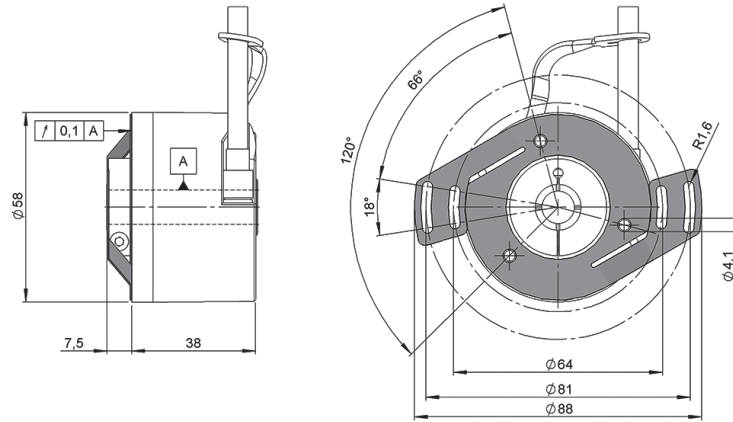

90.1075

