

xFUME VAC PRO

Powerful extraction system for up to four robot welding torches.

**As a system:
Perfect in a team
with ABIROB®
welding torches.**

The mobile extraction unit xFUME VAC PRO is suitable for 24-hour continuous operation and ideally designed for connection to ABICOR BINZEL robot welding torches.

- Highly efficient thanks to the high-vacuum technology with more than 26,000 PA negative pressure
- Up to four connections for extraction hoses
- Up to 30 m extraction hoses for easy connection to several welding robots
- Durable, low-maintenance side channel compressor
- Automatic filter cleaning by compressed air impulse
- Automatic start/stop via external control for reduced operating costs and less wear and tear
- Compact and robust design with castors for mobile use and easy transport

Technical details

Technical data

Description	Value
Engine performance	3,0 / 5,5 kW
Voltage	3P 230V 50 /60 Hz 3P 380V 50 /60 Hz
230V	ohne Stecker
380V	Stecker enthalten
Cable length	5 m
Max. air flow	450 - 700 m ³ /h
Max. vacuum	~ 26 000 PA
Noise level	≤ 75 dB (A)
Weight	3,0 kW 274 kg 5,5 kW 290 kg



Filter

Type	Material	Surface	Filtermaterial classification	Efficiency
Cartridge filter	HISTec >> PTFE coated	2 / 4 x 0,8 m ²	H13	≥ 99,95 %



xFUME VAC PRO

Detail

Order information

Extraction unit xFUME VAC Pro

Voltage	Order no.
3P 230V 3,0 kW 50/60Hz	601.0101.1
3P 230V 5,5 kW 50/60Hz	601.0102.1
3P 380V 3,0 kW 50/60Hz	601.0103.1
3P 380V 5,5 kW 50/60Hz	601.0104.1

Filter

Type	Order no.
Cartridge filter	601.0111.1

Dimensions

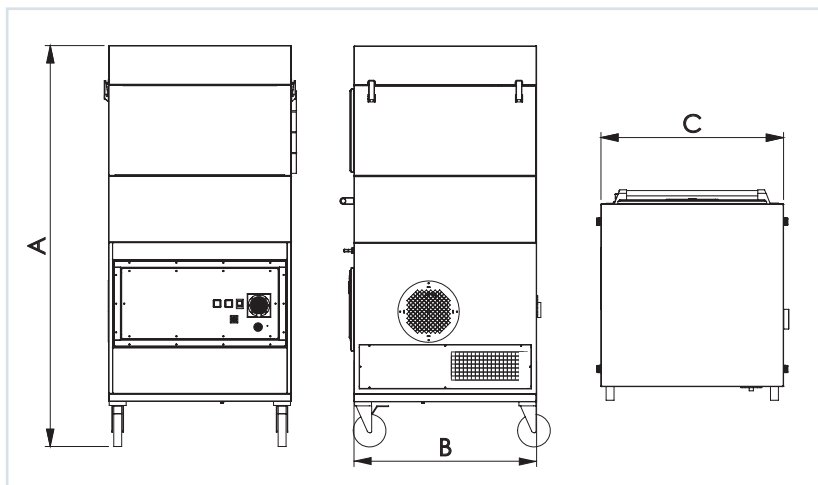

Dimensions

Side	Size
A	1540 mm
B	700 mm
C	700 mm

Further information



Explainer Video
now on YouTube.
Take a look!



Alexander Binzel Schweißtechnik GmbH & Co. KG
Kiesacker · 35418 Buseck · GERMANY
T +49 64 08 / 59-0
F +49 64 08 / 59-191
info@binzel-abicor.com

www.binzel-abicor.com