

Montage- und Einstellanleitung
 Installation and set-up manual

Ersatzteile Elektronik (BMU, AI) Spareparts electronics (BMU, AI)

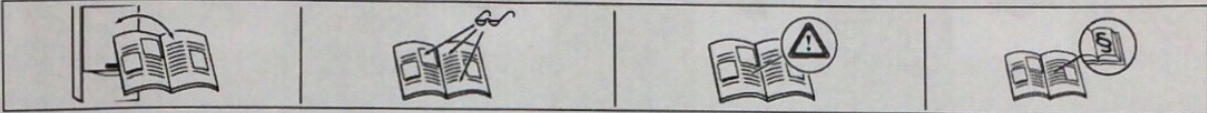

1 Austausch Platine (BMU) Replacing BMU

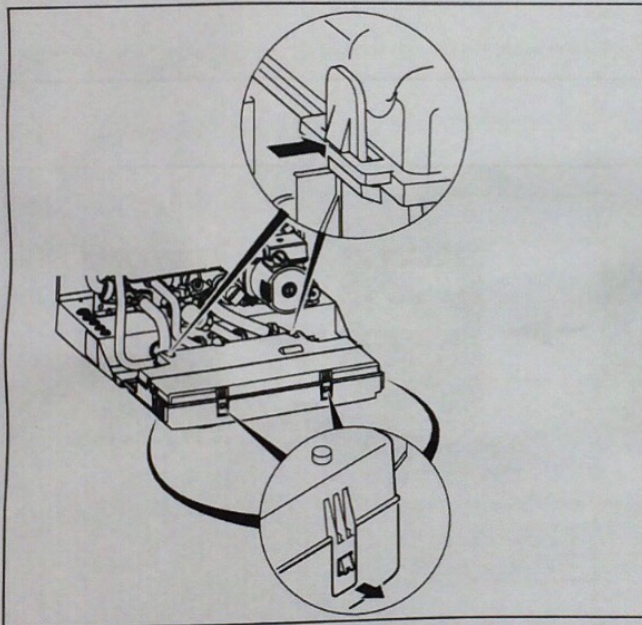

2 Austausch Display (AI) Replacing AI

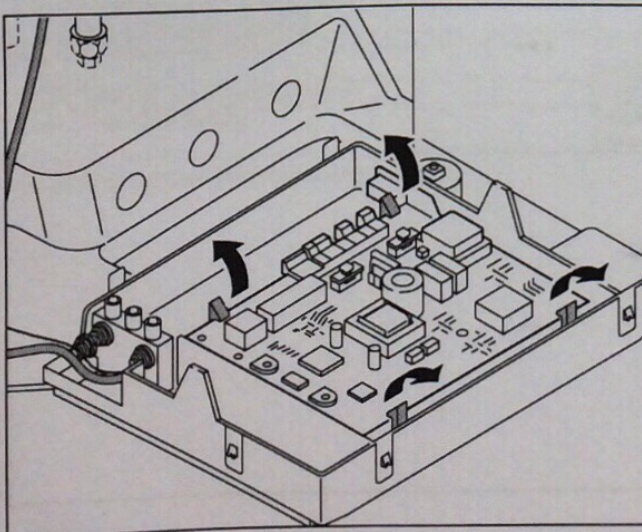
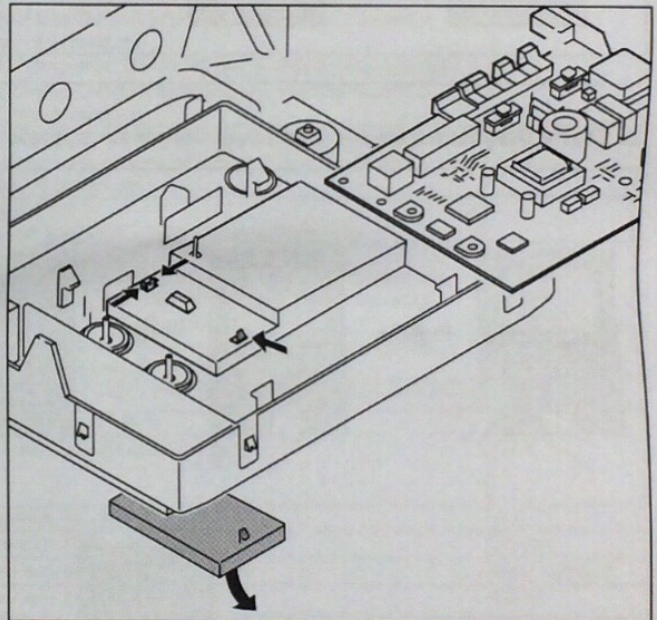

⚠ Achtung! Caution!
 7, 8, 9 & BUS:

~~230V~~ !!!

Einstellung des Gerätes (Diagnosemodus)
Adjustment appliances (Diagnosemode)

1. Ebene Diagnosesystem / 1st Level Diagnosticsystem

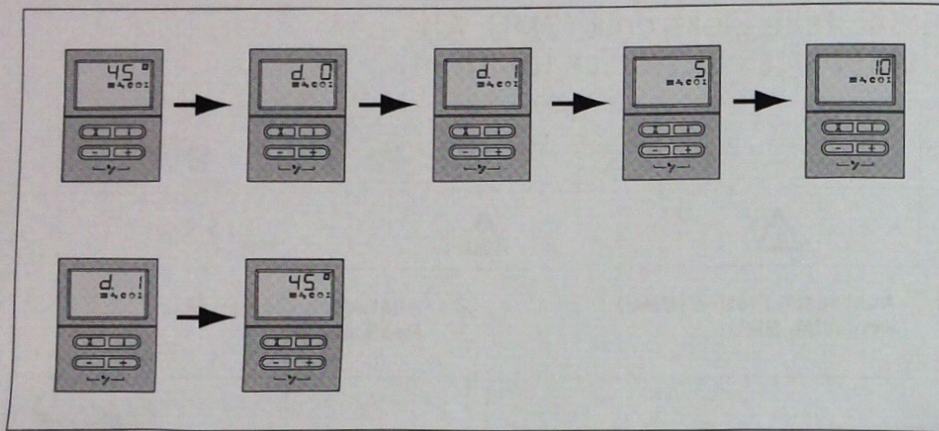

2. Ebene Diagnosesystem / 2nd Level Diagnosticsystem

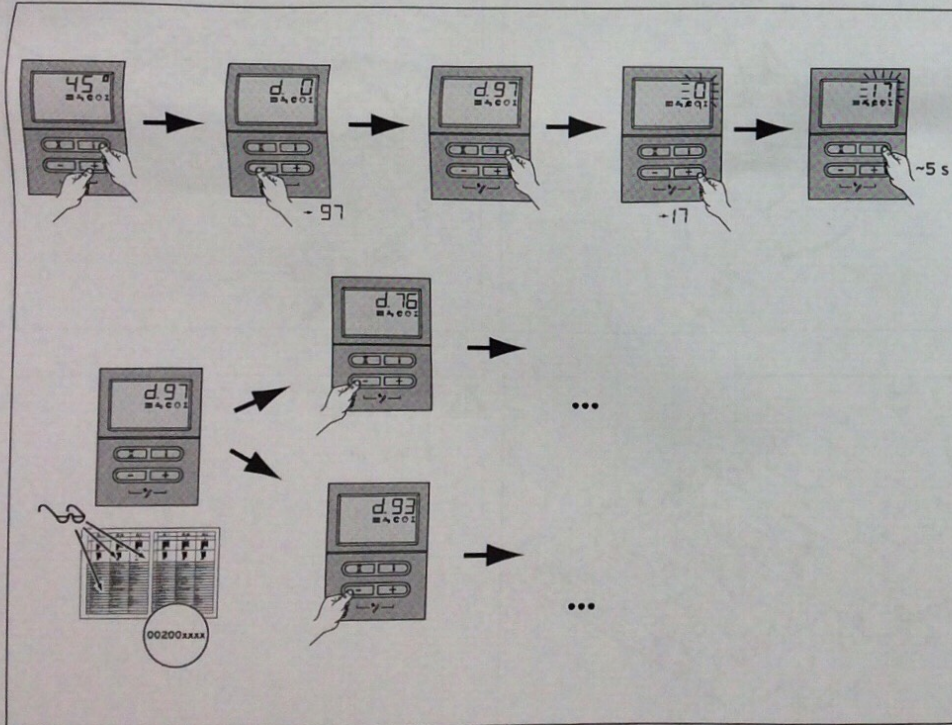

DE: Einstellung des Gerätes, Anpassung an die Heizungsanlage

Anzeige	Bedeutung	Einstellbare Werte	Werkseinstellung
d.0	Heizungsteillast	Heizungsteillast in KW; Einstellbereich: gerätespezifisch	max. Leistung
d.1	Wasserpumpennachlaufzeit für Heizbetrieb	Einstellbereich: 2,3...60 min	5 min
d.2	Maximale Brennersperrzeit bei 20 °C Vorlauftemperatur	Einstellbereich: 2,60 min	20 min
d.97	Aktivierung der 2. Diagnoseebene	Passwort: 17	

Tabelle 1: Einstellbare Werte der 1. Diagnoseebene

Anzeige	Bedeutung	Einstellbare Werte	Werkseinstellung
d.14	Einstellung für drehzahlgesteuerte interne Pumpe	0 = auto, 1 = 53%, 2 = 60%, 3 = 70%, 4 = 85%, 5 = 100%	0
d.17	Umschaltung Vorlauf/Rücklaufregelung Heizung	0 = Vorlauf; 1 = Rücklauf	0
d.18	Pumpenbetriebsart (Nachlauf)	0 = Nachlauf; 1 = Durchlaufend; 2 = Winter	0
d.19	Betriebsart 2-stufige Pumpe	Einstellung der Betriebsweise 2-stufige Pumpe: 0: Brennerbetrieb = Stufe 2, Vorlauf/Nachlauf = Stufe 1; 1: Heizung + Nachlauf = Stufe 1, Brauchwasser = Stufe 2, 2: wie Einstellung 1 aber Drehzahl bei Heizbetrieb abhängig von Heizungsteillast	2
d.20	Maximaler Einstellwert für Speichersollwert (nur VC)	Einstellbereich: 50 °C - 70 °C	65 °C
d.26	Umschaltung Optionsrelais auf BMU	1 = Zirkulationspumpe; 2 = ext.Pumpe; 3 = Speicherladepumpe; 4 = Abgasklappe/Dunstabzugshaube; 5 = externes Gasventil; 6 = externe Störmeldung	2
d.27	Umschalten Zubehörelais 1	1 = Zirkulationspumpe; 2 = ext.Pumpe; 3 = Speicherladepumpe; 4 = Abgasklappe/Dunstabzugshaube; 5 = externes Gasventil; 6 = externe Störmeldung	1
d.28	Umschalten Zubehörelais 2	1 = Zirkulationspumpe; 2 = ext.Pumpe; 3 = Speicherladepumpe; 4 = Abgasklappe/Dunstabzugshaube; 5 = externes Gasventil; 6 = externe Störmeldung	2
d.56	Einstellung Abgaskennlinie	Einstellbereich: 0..2; 0: Österreich Kennlinie; 1: Europa Standard Kennlinie	0
d.58	Aktivierung solare Nacherwärmung für VCW; Umschaltung Brauchwasserbetriebsart; Aktivierung Sollwert BW Minimum	Einstellbereich: 0..3 0: solare Nacherwärmung deaktiviert; 1: solare Nacherwärmung aktiviert für VCW und BW-Sollwert Minimum 60° (Poti), keine Deaktivierung bei „Poti-Linksanschlag“ 2: solare Nacherwärmung aktiviert; 3: solare Nacherwärmung deaktiviert, BW-Sollwert Minimum 60 °	0
d.70	Einstellung Vorrang-Umschaltventil-Stellung	0 = Normalbetrieb, 1 = Mittenstellung, 2 = dauerhafte Heizungsstellung	0
d.71	Sollwert max. Vorlauftemperatur Heizung	Einstellbereich: 40 °C..85 °C	75 °C
d.72	Pumpennachlaufzeit nach der Ladung eines von der TECtronic geregelten Brauchwasserspeichers (auch Warmstart und Ladung über CI/C2)	Einstellbereich: 0,10,20...600 s	80 s
d.73	Offset für Warmstartsollwert (nur VCW)	Einstellbereich: -15...5 K	0 K
d.75	max. Ladezeit Warmwasserspeicher ohne eigene Regelung	Einstellbereich: 20,21...90 min	45 min
d.77	Teillast bei Speicherladung (Speicherladebegrenzung, VC)	Einstellbereich: gerätespezifisch in kW	max. Leistung
d.78	Speicherladetemperaturbegrenzung	Einstellbereich: 55 °C bis 90 °C	80 °C
d.84	Wartungsanzeige: Anzahl der Stunden bis zur nächsten Wartung	Einstellbereich: 0...3000h und „-“ für deaktiviert (300 entspricht 3000h)	„-“
d.85	Anhebung der minimalen Geräteleistung zur Vermeidung von Schornsteinversottung	Einstellbereich: geräteabhängig; Angabe in KW	min. Leistung
d.88	Einschaltsschwelle zur Erkennung einer BW-Zapfung	0 = 1,5 l/min und keine Verzögerung, 1 = 3,7 l/min und 2 s Verzögerung	0
d.93	Einstellung Gerätevariante DSN	Einstellbereich: 0,99, siehe Beilage	
d.96	Werkseinstellung	Rücksetzung einstellbarer Parameter auf Werkseinstellung 0=aus, 1=ein	0

Tabelle 2: Einstellbare Werte der 2. Diagnoseebene

Display	Meaning	Adjustable value	Factory setting
d.0	Heating part load	Adjustable values in kW; Adjustment range: boiler specific	max. power
d.1	Waterpump overrun time for central heating mode	Adjustment range: 2,3...60 min	5 min
d.2	Maximum period after central heating operation at 20 °C	Adjustment range: 2..60 min	20 min
d.97	Aktivation of second diagnostic level	Password: 17	

Table 1: Adjustable values of the first diagnosis level

Display	Meaning	Adjustable value	Factory setting
d.14	Pump speed nominal value	0 = auto, 1 = 53%, 2 = 60%, 3 = 70%, 4 = 85%, 5 = 100%	0
d.17	Selection of temperature regulation: flow/return	0 = flow, 1 = return	0
d.18	Pump overrun mode	0 = overrun, 1 = continuous, 2 = winter	0
d.19	Operating modes of 2 speed pump	0: burner mode = 2, pre/post-run = 1; 1: CH + post-run = 1, DHW = 2; 2: as 1 but rotation speed in CH is dependent of heating part load 3: always stage 2	2
d.20	Maximum set value of the tank setpoint poti	Adjustment range: 50 °C - 70 °C	65 °C
d.26	Changeover accessory relay on BMU	1 = circulation pump; 2 = ext. pump; 3 = tank loading pump 4 = flue gas flap / kitchen hood; 5 = ext. gas valve; 6 = ext. fault signal	2
d.27	Changeover accessory relay 1	1 = circulation pump; 2 = ext. pump; 3 = tank loading pump 4 = flue gas flap / kitchen hood; 5 = ext. gas valve; 6 = ext. fault signal	1
d.28	Changeover accessory relay 2	1 = circulation pump; 2 = ext. pump; 3 = tank loading pump 4 = flue gas flap / kitchen hood; 5 = ext. gas valve; 6 = ext. fault signal	2
d.56	Adjustment for exhaust gas detection curve	Adjustment range: 0..2; 1: Europe standard curve	0
d.58	Aktivation of solar post heat function for combi boilers	Adjustment range: 0..3; 0: solar function deactivated; 1: solar function activated and DHW setpoint minimum 60 °C (No „Off-function“ with DHW potentiometer left position); 2: solar function activated; 3: solar function deactivated, DHW setpoint minimum 60 °C	0
d.70	Setting of the diverter valve position	0=normal mode, 1=middle position, 2=permanent CH position	0
d.71	Maximum heating flow temperature	Adjustment range: 40 °C..85 °C	75 °C
d.72	Pump overrun after loading a storage tank	Adjustment range: 0,10,20...600 s	80 s
d.73	Offset for warmstart set point	Adjustment range: -15...15 K	0 K
d.75	Maximum charging time for a storage without own control	Adjustment range: 20...90 min	45 min
d.77	Part load hot water	Adjustment range in kW: boiler specific	max. power
d.78	Limitation of hot water nominal value	Adjustment range: 55 °C to 90 °C	80 °C
d.84	Maintenance indicator: Number of hours until next service	Adjustment range: 0..3000h and „-“ (300 complies with 3000h)	„-“
d.85	Power increase (to avoid condensing water in chimney) Limitation of power downwards	Adjustment range in kW: boiler specific	min. power
d.88	Switching on threshold for recognizing water tapping	0 = 1,5 l/min and no delay, 1 = 3,7 l/min and 2s delay	0
d.93	Adjustment of Device Specific Number	Adjustment range: 0..99, see manual	0
d.96	reset adjustable parameters to the factory settings	setting range: 0=off, 1=on	0

Table 2: Adjustable values of the second diagnosis level

Affichage	Signification	Valeurs réglables	Réglage usine
d.0	Charge partielle du chauffage	Plage de réglage en KW: dépendant de l'appareil	puissance maxi
d.1	Temporisation pompes à eau pour mode chauffage	Plage de réglage: 2,3...60 min	5 min
d.2	Temps de blocage maxi chauffage à 20 °C température départ	Plage de réglage: 2..60 min	20 min
d.97	Activation du 2ème niveau de diagnostic	Mot de passe : 17	

Tableau 1 : Valeur de réglage du premier niveau de diagnostic

Affichage	Signification	Valeurs réglables	Réglage usine
d.14	Réglage de la pompe interne à vitesses variables	0 = auto, 1 = 53%, 2 = 60%, 3 = 70%, 4 = 85%, 5 = 100%;	0
d.17	Commutation régulation départ/retour chauffage	0 = départ, 1 = retour	0
d.18	Mode de fonctionnement de la pompe (temporisation)	0 = temporisation, 1 = continu, 2 = hiver	0
d.19	Modes de fonctionnement de la pompe de chauffage à 2 vitesses	0 = départ vitesse 1, eau chaude resp. chauffage vitesse 2, temporisation vitesse 1 1 = Départ vitesse 1, eau chaude vitesse 2, chauffage vitesse 1, temporisation vitesse 1 2 = comme 1 néanmoins chauffage selon d.0 3 = toujours vitesse 2	2
d.20	Valeur de réglage maximale pour valeur de consigne ballon (uniquement appareils VC)	Plage de réglage: 50 °C - 70 °C	65 °C
d.26	Commutation relais optionnel sur BMU	1 = pompe circulation; 2 = pompe ext.; 3 = pompe d'accumulation; 4 = clapet évacuation/hotte aspirante; 5 = vanne gaz externe, 6 = message d'erreur externe	2
d.27	Commutation relais 1 sur le module accessoires	1 = pompe circulation; 2 = pompe ext.; 3 = pompe d'accumulation 4 = clapet évacuation/hotte aspirante; 5 = vanne gaz externe 6 = message d'erreur externe	1
d.28	Commutation relais 2 sur le module accessoires	1 = pompe circulation; 2 = pompe ext.; 3 = pompe d'accumulation 4 = clapet évacuation/hotte aspirante; 5 = vanne gaz externe 6 = message d'erreur externe	2
d.56	Réglage courbe caractéristique gaz d'échappement	Plage de réglage: 0..2; 1: Courbe caractéristique Standard Europe	0
d.58	Activation réchauffement solaire pour VCW; Commutation mode eau sanitaire; Activation valeur consigne VC minimum	Plage de réglage: 0..3; 0: réchauffement solaire désactivé; 1: réchauffement solaire activé pour VCW et VC Valeur consigne minimum 60° (Potentiomètre); pas de désactivation par „potentiomètre en butée gauche“; 2: réchauffement solaire activé pour VCW et VC Valeur consigne; 3: réchauffement solaire désactivé, valeur consigne VC minimum 60°	0
d.70	Réglage position vanne trois voies	0 = mode normal, 1 = position centrale, 2 = position chauffage permanent	0
d.71	Valeur consigne température départ chauffage maxi	Plage de réglage: 40 °C..85 °C	75 °C
d.72	Temporisation pompe après démarrage à chaude (uniquement VCW) ou après chargement d'un ballon 'eau ude à régulation électronique via CI-C2 (uniquement VC)	Plage de réglage: 0,10,20...600 s	80 s
d.73	Offset pour valeur consigne démarrage à chaud (uniquement VCW)	Plage de réglage: -15...5 K	0 K
d.75	Temps de charge maximal pour ballon d'eau chaude sans propre régulation (uniquement VC)	Plage de réglage: 20,21...90 min	45 min
d.77	Charge partielle durant accumulation du ballon (limitation charge ballon, uniquement VC)	Plage de réglage en kW: dépendant de l'appareil	puissance maxi
d.78	Valeur consigne température départ maxi en mode charge ballon (uniquement VC)	Plage de réglage: 55 °C bis 90 °C	80 °C
d.84	Affichage de l'entretien : Nombre d'heures jusqu'au prochain entretien	Plage de réglage: 0..3000h et „-“ (300 correspond 3000h)	„-“
d.85	Augmentation de la puissance minimale pour éviter encrassement cheminée	Plage de réglage: dépendant de l'appareil	puissance mini
d.88	Seuil d'activation pour détection d'un soutirage VC	0 = 1,5 l/min et pas de temporisation, 1 = 3,7 l/min et 2 s de temporisation	0
d.93	Réglage modèle DSN	Plage de réglage: 0..99, voir annexe	
d.96	Réglage d'usine (Restauration des paramètres réglages)	Plage de réglage: 0 = arrêt, 1 = marche	0

Tableau 2 : Valeur de réglage du deuxième niveau de diagnostic

Indicazione	Significato	Valori regolabili	Impostazione di fabbrica
d.0	Carico parziale riscaldamento regolabile	Campo di regolazione in kW: a seconda dell'apparecchio	potenza max.
d.1	Post-funzionamento della pompa dell'acqua per il riscaldamento	Campo di regolazione: 2,3...60 min	5 min
d.2	Tempo di blocco max. riscaldamento a una temperatura di mandata di 20 °C	Campo di regolazione: 2...60 min	20 min
d.97	Attivazione del 2° livello di diagnosi	Password: 17	

Tabella 1: valori impostabili del 1° livello di diagnostica

Indicazione	Significato	Valori regolabili	Impostazione di fabbrica
d.14	Regolazione per la pompa interna a velocità variabile	0 = auto, 1 = 53%, 2 = 60%, 3 = 70%, 4 = 85%, 5 = 100%	0
d.17	Commutazione mandata/ritorno riscaldamento	0 = mandata, 1 = riscaldamento; impostazione di fabbrica:	0
d.18	Tipo di funzionamento della pompa (post-funzionamento)	0 = post-funzionamento, 1 = continuo, 2 = inverno	0
d.19	Modalità di funzionamento pompa a 2 stadi	0: Funzionamento bruciatore = stadio 2, mandata/post-funzionamento = stadio 1; 1: riscaldamento + post-funzionamento = stadio 1, acqua sanitaria = stadio 2; 2: come impostazione 1 ma velocità in modalità riscaldamento in relazione al carico parziale riscaldamento	2
d.20	Valore di regolazione massimo del potenziometro valore nominale boiler	Campo di regolazione: 50 °C - 70 °C	65 °C
d.26	Commutazione relè accessorio su BMU	1 = pompa di circolazione; 2 = pompa est.; 3 = pompa di carico del boiler; 4 = sportello fumi/cappa di aspirazione; 5 = valvola a gas esterna; 6 = segnalazione d'errore esterna	2
d.27	Commutazione del relè accessorio 1	1 = pompa di circolazione; 2 = pompa est.; 3 = pompa di carico del boiler; 4 = sportello fumi/cappa di aspirazione; 5 = valvola a gas esterna; 6 = segnalazione d'errore esterna	1
d.28	Commutazione del relè accessorio 2	1 = pompa di circolazione; 2 = pompa est.; 3 = pompa di carico del boiler; 4 = sportello fumi/cappa di aspirazione; 5 = valvola a gas esterna; 6 = segnalazione d'errore esterna	2
d.56	Impostazione della linea caratteristica fumi	Campo di regolazione: 0..2 1: linea caratteristica standard per l'Europa	0
d.58	Attivazione del riscaldamento solare integrativo per VMW; commutazione del tipo di funzionamento dell'acqua potabile; attivazione del valore nominale minimo dell'acqua non potabile	Campo di regolazione: 0..3; 0: riscaldamento solare integrativo disattivato; 1: riscaldamento solare integrativo attivato per VMW e acqua potabile con valore nominale minimo 60° (potenziometro). Nessuna disattivazione in caso di "potenziometro tutto a sinistra"; 2: riscaldamento solare integrativo attivato per VMW e acqua potabile con valore nominale pari a VMW (min 35°); 3: attivazione 1 valore nominale minimo di 60° dell'acqua potabile (per VC e VMW) (senza riscaldamento solare integrativo) Nessuna disattivazione in caso di "potenziometro completamente a sinistra"	0
d.70	Regolazione della posizione della valvola deviatrice di priorità	0 = funzionamento normale; 1 = posizione centrale 2 = posizione riscaldamento permanente	0
d.71	Valore nominale massima temperatura di mandata riscaldamento	Campo di regolazione: 40 °C...85 °C	75 °C
d.72	Tempo di ritardo della pompa in seguito alla regolazione del caricamento di un serbatoio dell'acqua non potabile svolta da TECTronic (anche l'avvio del calore e il caricamento avvengono mediante CI/C2).	Campo di regolazione: 0,10,20...600 s	80 s
d.73	Offset per valore nominale di avvio del calore	Campo di regolazione: -15...5 K	0 K
d.75	Tempo max. di carico boiler per boiler senza controllo autonomo	Campo di regolazione: 20,21...90 min	45 min
d.77	Carico parziale boiler (limitazione potenza di carico boiler)	Campo di regolazione in kW: geratespezifisch	potenza max.
d.78	Limitazione temperatura di carico boiler	Campo di regolazione: 55 °C...90 °C	80 °C
d.84	Indicazione di manutenzione: numero di ore fino alla manutenzione successiva	Campo di regolazione: 0...3000h e "... (300 corrisponde a 3000h)	"..."
d.85	Aumento di potenza (funzione anticatrame della canna fumaria) limitazione verso il basso della potenza dell'apparecchio per evitare che la canna fumaria si incatrami	Campo di regolazione: a seconda dell'apparecchio	potenza min.
d.88	Limite di regolazione per riconoscimento di un prelievo acqua	0 = 1,5 l/min, nessun ritardo; 1 = 3,7 l/min, 2 sec. ritardo	0
d.93	Impostazione versione della caldaia DNS	Campo di regolazione: 0..99, vedere allegato	0
d.96	Impostazione di fabbrica (ripristino dei parametri impostabili ai valori dell'impostazione di fabbrica)	Campo di regolazione: 0 = off, 1 = on	0

Tabella 2: valori impostabili del 2° livello di diagnostica

Indicación	Significado	Valores ajustables	Ajuste de fábrica
d.0	Solicitación parcial de la calefacción, ajustable	Rango de ajuste en kW: específico del aparato	potencia máx.
d.1	Inercia de la bomba de agua para modo de calefacción	Rango de ajuste: 2,3...60 min	5 min
d.2	Tiempo de bloqueo máximo calefacción a temperatura de ida de 20 °C	Rango de ajuste: 2...60 min	20 min
d.97	Activación del 2º nivel de diagnóstico	Contraseña: 17	

Tabla 1: valores ajustables del primer nivel de diagnóstico

Indicación	Significado	Valores ajustables	Ajuste de fábrica
d.14	Ajuste de la bomba interna controlada por revoluciones	0 = auto, 1 = 53%, 2 = 60%, 3 = 70%, 4 = 85%, 5 = 100%	0
d.17	Cambio entre regulación de ida/retorno de calefacción	0 = ida, 1 = retorno	0
d.18	Funcionamiento de la bomba (retorno)	0 = retorno, 1 = continuo, 2 = invierno	0
d.19	Modo de funcionamiento de la bomba de dos niveles	0: modo antorcha = nivel 2, marcha adelante/marcha atrás = nivel 1; 1: calefacción + marcha atrás = nivel 1, agua industrial = nivel 2, 2: como ajuste 1 pero el número de revoluciones para modo calefacción depende de la carga parcial de la calefacción	2
d.20	Valor de ajuste máximo del valor nominal de memorización del potenciómetro	Rango de ajuste: 50 °C - 70 °C	65 °C
d.26	Commutación del relé opcional de BMU	1 = Bomba de recirculación; 2 = Bomba ext.; 3 = Bomba de sobrealimentación; 4 = Panel de salida de gases/campana extractora 5 = Válvula de gas externa; 6 = Mensaje de fallo externo	2
d.27	Conmutar relé auxiliar 1	1 = Bomba de recirculación; 2 = Bomba ext.; 3 = Bomba de sobrealimentación; 4 = Panel de salida de gases/campana extractora 5 = Válvula de gas externa; 6 = Mensaje de fallo externo	1
d.28	Conmutar relé auxiliar 2	1 = Bomba de recirculación; 2 = Bomba ext.; 3 = Bomba de sobrealimentación; 4 = Panel de salida de gases/campana extractora 5 = Válvula de gas externa; 6 = Mensaje de fallo externo	2
d.56	Ajuste de la curva característica de salida de gases	Rango de ajuste: 0..2 1: curva característica estándar europea	0
d.58	Activación de calentamiento de apoyo solar para VCW, conmutación del modo de funcionamiento de agua sanitaria, activación del valor nominal de agua sanitaria mínimo	Rango de ajuste: 0..3 0: calentamiento de apoyo solar desactivado 1: calentamiento de apoyo solar activado para VCW y valor nominal de agua sanitaria mínimo 60° (potenciómetro). Sin desactivación en el "tope izquierdo del potenciómetro" 2: calentamiento de apoyo solar activado para VCW y valor nominal de agua sanitaria como VCW (mínimo 35°); 3: activación del valor nominal de agua sanitaria mínimo de 60° (para VC y VCW), (sin calentamiento de apoyo solar). Sin desactivación en el "tope izquierdo del potenciómetro"	0
d.70	Ajuste de la posición de la válvula selector de prioridad	0 = funcionamiento normal; 1 = posición central 2 = posición de calefacción permanente	0
d.71	Valor nominal máx. de la temperatura de ida calefacción	Rango de ajuste: 40 °C...85 °C	75 °C
d.72	Inercia de la bomba después de cargar uno de los acumuladores de agua sanitaria regulado por TECTronic (también inicio en caliente y carga a través de CI/C2)	Rango de ajuste: 0,10,20...600 s	80 s
d.73	Parámetro del valor nominal de inicio en caliente	Rango de ajuste: -15...5 K	0 K
d.75	Tiempo máximo de carga de memoria Memoria sin control propio	Rango de ajuste: 20,21...90 min	45 min
d.77	Carga parcial de memorización (limitación de la potencia de carga de memoria)	Rango de ajuste en kW: específico del aparato	potencia máx
d.78	Limitación de la temperatura de carga máxima	Rango de ajuste: 55 °C bis 90 °C	80 °C
d.84	Indicación de mantenimiento: número de horas hasta el próximo mantenimiento	Rango de ajuste: 0...3000h y "... (300 se corresponde a 3000h)	"..."
d.85	Aumento de potencia (función que evita la acumulación de hollín en la chimenea)	Rango de ajuste: en función del aparato	potencia min
d.88	Umbral de ajuste para el reconocimiento de distribución de agua de consumo	0 = 1,5 l/min, sin retardo; 1 = 3,7 l/min, 2 segundos retardo	0
d.93	Ajuste variantes del aparato DSN	Rango de ajuste: 0..99, ver anexo	0
d.96	Ajuste de fábrica (restaurar los parámetros ajustables a ajuste de fábrica)	Rango de ajuste: 0 = aus, 1 = ein	0

Tabla 2: valores ajustables del segundo nivel de diagnóstico

NL: Instelling van het toestel, aanpassing aan de cv-installatie

Indicatie	Betekenis	Instelbare waarden	fabriek- instelling
d.0	Verwarmingsdeellast	Instelbereik verwarmingsdeellast in kW: toestelspecifiek	max. vermogen
d.1	Waterpompnalooptijd voor verwarmingsmodus	Instelbereik: 2,3...60 min	5 min
d.2	Max. blokkeertijd verwarming bij 20 °C Voorlooptemperatuur	Instelbereik: 2..60 min	20 min
d.97	Activering van het 2e diagnosesniveau	Paswoord: 17	

Tabel 1: Instelbare waarden van het 1e diagnosesniveau

Indicatie	Betekenis	Instelbare waarden	fabriek- instelling
d.14	Instelling voor toerentalgestuurde interne pomp	0 = auto, 1 = 53%, 2 = 60%, 3 = 70%, 4 = 85%, 5 = 100%	0
d.17	Omschakeling voorloop-/terugloopregeling verwarming	0 = voorloop, 1 = terugloop	0
d.18	Pompmodus (nalooop)	0 = nalooop, 1 = doorlopend, 2 = winter; fabrieksinstelling: 0	0
d.19	Modi van de 2-traps verwarmingspomp	0 = voorloop stand 1, warmwater resp. verwarming stand 2, nalooop stand 1 1 = voorloop stand 1, warmwater stand 2, verwarming stand 1, nalooop stand 1; 2 = zoals 1, maar verwarming afhankelijk van d.0; 3 = altijd stand 2	2
d.20	Maximale instelwaarde voor gewenste boilerwaarde (alleen VC-toestellen)	Instelbereik: 50 °C - 70 °C	65 °C
d.26	Omschakeling optierelais op BMU	1 = circulatiepomp; 2 = ext. pomp; 3 = boilerlaadpomp; 4 = verbrandings- gasklep/ damafzuigkap; 5 = extern gasventiel; 6 = externe foutmelding	2
d.27	Omschakeling relais 1 op de toebehorenmodule	1 = circulatiepomp; 2 = ext. pomp; 3 = boilerlaadpomp; 4 = verbrandings- gasklep/damafzuigkap; 5 = extern gasventiel; 6 = externe foutmelding	1
d.28	Omschakeling relais 2 op de toebehorenmodule	1 = circulatiepomp; 2 = ext. pomp; 3 = boilerlaadpomp; 4 = verbrandings- gasklep/damafzuigkap; 5 = extern gasventiel; 6 = externe foutmelding	2
d.56	Instelling verbrandingsgaskarakteristiek	Instelbereik: 0..2; 1: Europa standaard karakteristiek	0
d.58	Activering naverwarming via zonne-energie voor VCW Omschakeling gebruikswatermodus Activering gewenste waarde BW minimum	Instelbereik: 0..3 0: naverwarming via zonne-energie gedeactiveerd; 1: naverwarming via zonne-energie geactiveerd voor VCW en BW gewenste waarde minimum 60° (potentiometer); geen deactivering bij "linkse aanslag potentiometer" 2: naverwarming via zonne-energie geactiveerd voor VCW en BW gewenste waarde; 3: naverwarming via zonne-energie gedeactiveerd, BW gewenste waarde minimum 60°	0
d.70	Instellen voorrangsomschakelventielstand	0 = normaal bedrijf; 1 = middelste stand; 2 = permanente verwarmingsstand	0
d.71	Gewenste waarde max. voorlooptemperatuur verwarming	Instelbereik: 40 °C..85 °C	75 °C
d.72	Pompnalooptijd na warme start (alleen VCW) of na het laden van een elektronisch geregelde warmwaterboiler via C1-C2 (alleen VC)	Instelbereik: 0;10,20...600 s	80 s
d.73	Offset voor gewenste warme startwaarde (alleen VCW)	Instelbereik: -15...5 K	0 K
d.75	Maximale laadtijd voor warmwaterboiler zonder eigen regeling (alleen VC)	Instelbereik: 20,21, ...90 min	45 min
d.77	Deellast bij boilerlading (boilerlaadbegrenzing, alleen VC)	Instelbereik in kW: toestelspecifiek	max. vermogen
d.78	Gewenste waarde max. voorlooptemperatuur in de boilerlaadmodus (alleen VC)	Instelbereik: 55 °C bis 90 °C	80 °C
d.84	Onderhoudsindicatie: aantal uur tot het volgende onderhoud	Instelbereik: 0...3000h en „-“ (300 komt overeen met 3000h)	„-“
d.85	Verhoging van het minimale toestelvermogen om te vermijden dat de schoorsteen vol roet en teer raakt	Instelbereik: toestelafhankelijk	min. vermogen
d.88	Inschakeldrempel voor de herkenning van het tappen van bruikwater	0 = 1,5 l/min en geen vertraging, 1 = 3,7 l/min en 2 s vertraging	0
d.93	Instelling toestelvariant DSN	Instelbereik: 0..99, zie bijlage	
d.96	Fabrieksinstelling (resetten van instelbare parameters op fabrieksinstelling)	Instelbereik: 0 = uit, 1 = aan	0

Tabel 2: Instelbare waarden van het 2e diagnosesniveau

Vaillant G.m.b.H

Berghauser Str. 40 ■ 42859 Remscheid ■ Telefon 0 21 91/ 18-0

Telefax 0 21 91/ 18-22 76 ■ www.vaillant.de ■ info@vaillant.de

0020030769_01 INT 112009