

Operating Instructions

DULCOMETER® DMT

On-site measurement transducer

Measured variable chlorine

only for DMT sensors

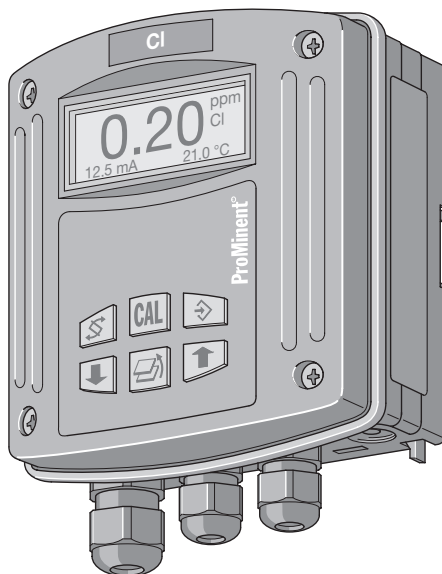

DMTa _____

Please enter the identity code for your device here!

**Please read the operating instructions through completely before
commissioning this equipment! · Do not discard!
The operator shall be liable for any damage caused by installation or operating errors!**

Publishing details:

Operating Instructions
DULCOMETER® DMT on-site measurement transducer
Measured variable chlorine only for DMT sensors
© ProMinent Dosiertechnik GmbH, 2000

Address:

ProMinent Dosiertechnik GmbH
Im Schuhmachergewann 5-11
69123 Heidelberg
Germany

Phone: +49 6221 842-0

Fax: +49 6221 842-419

info@prominent.com

www.prominent.com

Subject to technical alterations.

Table of contents

Device identification/identity code chlorine	5
General instructions for use	6
1 About this device	7
2 Safety	7
2.1 Correct use	7
2.2 Safety guidelines	7
3 Storage and transport	7
4 Assembly and installation	8
4.1 Assembly (mechanical)	8
4.1.1 Wall mounting	8
4.1.2 Pipe mounting	9
4.1.3 Panel mounting	10
4.2 Installation (electrical)	11
4.2.1 Wall mounting	12
4.2.2 Pipe mounting	13
4.2.3 Panel mounting	13
4.2.4 Connecting terminals	14
5 Device overview and control elements	15
6 Function description	16
6.1 General	16
6.2 Key functions	17
6.3 Operating menu, schematic	17
6.4 Negotiating operating menu	18
6.4.1 Calibration menu	19
6.4.2 Info-Display	19
6.4.3 Menu options	19
6.4.4 Negotiating the menu options	19

Table of contents

7	DMT settings	20
7.1	Measured variable chlorine	21
7.1.1	Menu overview: Measured variable chlorine	21
7.1.2	Parameter measurement	22
7.1.3	Parameter temperature	22
7.1.4	Parameter output	24
7.1.5	General settings	26
8	Operating the DMT	28
8.1	Permanent display	28
8.1.1	Brightness of LC display	28
8.2	Calibration	28
8.2.1	Calibration process	28
9	Troubleshooting	31
9.1	Error messages during operation	31
9.2	Error messages during calibration	32
10	Maintenance and repair	33
11	Disposal	33
12	Technical data	34
13	Spare parts and accessories	35
Appendix		
	Declaration of conformity	36
	Terminal connection plan chlorine	37
	Wiring example - two wire system	38
	PROFIBUS® circuit board terminal connection	39
	Index	40
	Drilling template for DMT	43

Device identification/identity code: measured variable chlorine

DMTa	DULCOMETER® DMT series measurement transducer	
	Mounting type	
W	wall/pipe mounted	
S	control panel mounted (not PROFIBUS®-DMT)	
	Version	
0	with ProMinent logo	
	Electrical connection	
9	4-20 mA two wire	
5	PROFIBUS®-DP, 24 V DC (16...30 V DC)	
	Communication interface	
0	none	
4	PROFIBUS®-DP	
	Measured variable	
C	chlorine	
	Correction variable	
0	none	
1	temperature (Pt 1000/Pt 100)	
	Enclosure rating	
0	standard	

Adjustable via general settings:

	Language
D	German
E	English
F	French
S	Spanish
I	Italian
	Chlorine sensor type
0	CLE 5 ppm
4	CTE 10 ppm
5	CLE 50 ppm
	Temperature measurement
0	automatic (Pt 1000 or Pt 100)
1	manual
2	automatic or manual
	Output
0	measured variable (fault: 23 mA, calibration: 23 mA)
1	manually adjustable current value
2	measured variable or manual (fault: 23 mA, calibration: 23 mA)
3	measured variable or manual (fault: 23 mA, calibration: HOLD)
4	4 mA constant current
	Other settings
0	standard

DMTa _____

Please enter the identity code for your device here!

General instructions for use

Please read through these instructions for use carefully! They will enable you to make the best possible use of this operating instructions manual.

The following sections are highlighted in the text:

- Enumerated points
- ▶ Instructions

Working instructions:

NOTE

Guidelines are intended to make your work easier.

and safety instructions:



CAUTION

***Describes a potentially dangerous situation.
Non-observance can lead to personal injury or damage to property!***



IMPORTANT

***Describes a potentially dangerous situation.
Non-observance can lead to damage to property.***

1 About this device

The measurement DULCOMETER® DMT for conductive conductivity is a two-wire measurement transducer for use in all areas of process and process technology in non-explosive areas.

It shows the electrolytic conductivity and/or specific resistance and produces a proportional output signal.

An optimum PROFIBUS®-DP interface enables e.g. read out of the measurement, correction and calibration values of the measurement transducer by a PC or PLC and provides a superseding system.

PROFIBUS®-DP is a manufacturer-independent interface.

2 Safety

2.1 Correct use

The DMT on-site measurement transducer is designed exclusively for the

- measurement of chlorine concentration
- measurement of temperature
- display of measured variables
- production of an output signal
- for the connection of DMT sensors

It is prohibited to use the device for any other applications or to modify it in any way!

Do not use the device out of doors without additional protection (protective housing, weatherproof cover).

The DMT measurement transducer is not suitable for use in explosive areas.

2.2 Safety guidelines



CAUTION

- *The device must not be used in a possible explosion area!*
- *The DMT must be operated by trained and authorised personnel!*



IMPORTANT

- *The system must be suitably equipped and configured to prevent overdosing of hazardous materials due to sensor failure.*
- *The DMT has no on/off switch. It starts to function as soon as it is connected to a power supply.*

3 Storage and transport

Store and transport the DMT in the original packaging!



IMPORTANT

- *Protect the DMT from damp and the effects of chemicals even when packed!*

Ambient conditions for storage and transport:

Temperature:	-20 °C to 70 °C
Humidity:	max. 95 % relative humidity, non condensing

4 Assembly and installation



IMPORTANT

- **The DMT is fully resistant to normal environments control rooms.**
- **The DMT must be protected against rain and direct sunlight!**
Use a protective housing or weatherproof cover if in use out of doors!

4.1 Assembly (mechanical)

The DMT can be wall, pipe or panel mounted.

4.1.1 Wall mounting

Mounting materials (included in delivery):

- 1 x wall/pipe bracket
- 2 x 5x45 mm round headed screws
- 2 x 5.3 washers
- 2 x 8 mm diameter plugs, plastic
- 1 x rubber insert
- 1 x locking screw (PT)

Wall mounting, please follow the steps below:

- ▶ Remove wall/pipe bracket from DMT:
Pull the two snap fasteners outwards and push upwards (fig. 1, ①).
Swing the wall/pipe bracket away from the DMT and pull downwards (fig. 1, ②).
- ▶ Mark two drill holes diagonally opposite one another using the mounting bracket as a template.
- ▶ Drill the holes: Ø 8 mm, depth = 50 mm.
- ▶ Screw the wall/pipe bracket in place inserting the washers (fig. 2).
- ▶ If the DMT is also to be secured with a screw, pierce the screw hole in the back of the housing (housing must be open) and attach a rubber insert (fig. 2, ①) to the bracket.
- ▶ Hang the DMT onto the top of the bracket (fig. 3, ①) and push down gently against the bracket (fig. 3, ②); then push upwards until you hear a click (fig. 3, ③).
- ▶ Tighten the locking screw to secure more firmly (housing is open).

Fig. 1

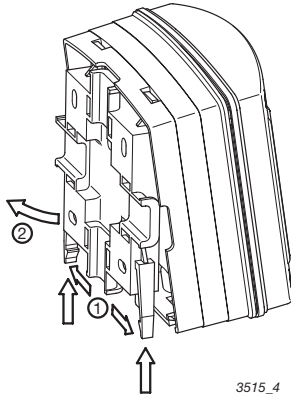

Fig. 2

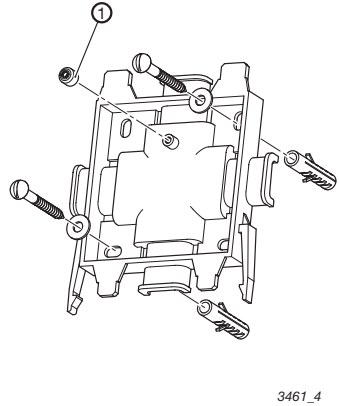
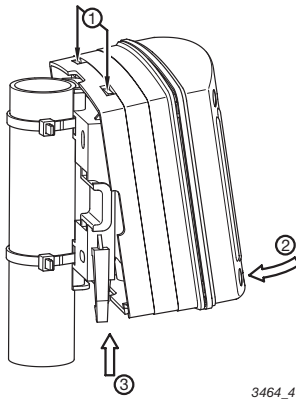

Fig. 3



4.1.2 Pipe mounting

Mounting material (included in delivery):

- 1 x wall/pipe bracket
- 2 x cable ties
- 1 x sealing cap
- 1 x locking screw (PT)

Can be mounted onto pipes of diameters from 25 mm to 60 mm.

Pipe mounting, please follow the steps below:

- ▶ Remove wall/pipe bracket from DMT:
Pull the two snap fasteners outwards and push upwards (fig. 1, ①).
Swing the wall/pipe bracket away from the DMT and pull downwards (fig. 1, ②).
- ▶ Fasten the bracket to the pipe using the cable ties (or pipe clamps) (fig. 3).
- ▶ If the DMT is also to be secured with a screw, pierce the screw hole in the back of the housing (housing must be open) and attach a rubber insert (fig. 2, ①) to the bracket.
- ▶ Hang the DMT onto the top of the bracket (fig. 3, ①) and push down gently against the bracket (fig. 3, ②); then push upwards until you hear a click (fig. 3, ③).
- ▶ Tighten the locking screw to secure more firmly (housing is open).

4.1.3 Panel mounting



IMPORTANT

- **The control panel must be thick enough not to buckle once installed. (To achieve enclosure rating IP 54, steel must be at least 2 mm thick; plastic should be correspondingly thicker.)**

NOTE

The DMT will protrude from the control panel approx. 30 mm once mounted.

Fig. 4

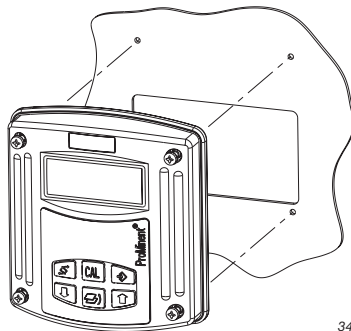

3463_4

Panel mounting, please follow the steps below:

- ▶ Decide on the exact position of the DMT on the panel using the drill template.
- ▶ Centre punch the holes for the screws and cut-out through the drilling template.
- ▶ Drill the four screw holes with a \varnothing 3.5 mm diameter drill bit.
- ▶ Punch out the cut-out or drill the four inner holes using an \varnothing 8 mm diameter drill bit and pierce out the cut-out with a keyhole saw.



CAUTION

Sharp edges can cause injury!

- ▶ File off cut edges.
- ▶ Insert the profile seal into the groove provided on the DMT.
- ▶ Place the DMT onto the cut-out and screw in place.



IMPORTANT

Check that the seal is located correctly.

IP 54 is only achieved when assembly has been carried out correctly.

4.2 Installation (electrical)



IMPORTANT

- ***Installation must be carried out by specially trained personnel.***
- ***Installation can only be carried out after assembly has been completed.***
- ***The device must be connected to a protective low voltage in accordance with EN 60335-1.***
- ***Observe the relevant technical data in chapter 12 throughout installation procedures.***
- ***The ring circuit must be disconnected from the power supply during installation.***
- ***The DMT signal cable must not be laid next to leads subject to high levels of interference. Can lead to malfunction of DMT.***
- ***The hinge between the front and back sections of the housing is not particularly strong. When working on the front section it should be held securely in place.***

4.2.1 Wall mounting

- ▶ Unfasten the four housing screws.
- ▶ Lift the front section slightly forwards and then swing open to the left.

NOTE

- *For smaller screw fittings (M 16 x 1.5), the cable for power supply should be installed on the left. Then, the cables for further sensors (e.g. Pt 1000) follow.*
 - *Push the 5-core signal cable through the small threaded connector (M 16 x 1.5) to the far left.*
- ▶ Pierce threaded cable apertures at the bottom of the rear side as required (fig. 5).

Fig. 5

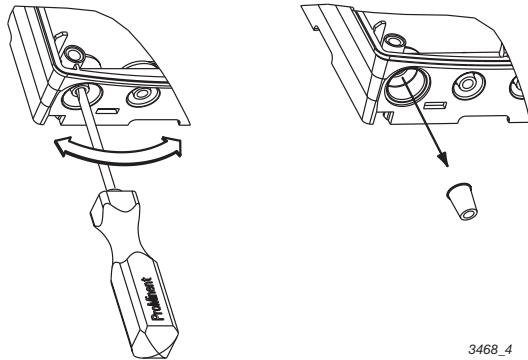

- ▶ Tighten the threaded connectors (fig. 6, ①) as required.
- ▶ Use reducers as required (fig. 6, ②) to adapt the sizes of the threaded connectors to the actual cable diameters.
- ▶ Feed the cables into the threaded connectors.
- ▶ Now proceed according to 4.2.4 Connecting terminals.

Then follow the steps below:

- ▶ Tighten the locking screws (fig. 6, ③) for the threaded connectors.
- ▶ Swing the front section onto the back section.



IMPORTANT

**Check that the seal is located correctly. IP 65 is achieved only when assembly has been carried out correctly.
(If necessary pull the front section forward in order to reduce the stress on the seal.)**

- ▶ Tighten the housing screws finger tight.

Fig. 6

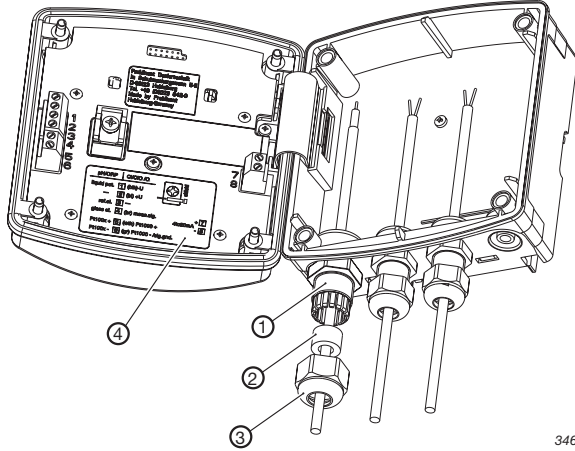

3465_3

4.2.2 Pipe mounting

See 4.2.1 Wall mounting

Fig. 6.1

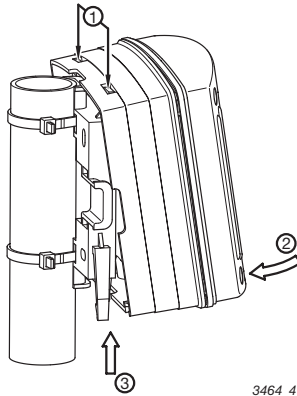

3464_4

4.2.3 Panel mounting

NOTE

The cable must be laid in cable ducting on site to minimise stresses.

Connect the cable from the back through the cut-out in the control panel:

- Follow the steps given in 4.2.4 Connecting terminals.

4.2.4 Connecting terminals

- ▶ Remove insulation from cable ends as shown in fig. 7 (right) and attach end crimps to each core.
- ▶ Connect the cables in accordance with the terminal connection plan (see appendix).



IMPORTANT

- **A Pt 100/Pt 1000 must be connected!**
- **Do not operate PROFIBUS® variants at voltages over 30 V.**
- **Connect PROFIBUS® variant power supplies via terminals 3 and 4 on the PROFIBUS® circuit board in the back section, not terminals 7 and 8 in the front section.**

NOTE

- **The terminal connection plan is given in the appendix. There is also a panel giving connection information affixed to the housing near the terminals (fig. 6, ④ and fig. 8).**
- **Remove the tag from the signal cable and dispose of appropriately.**
- **Push the cable through the housing until the front section can be moved up and down easily.**
- **If the LC display is too weak, reduce the brightness using the up arrow key . If the display is too dark, increase the brightness using the down arrow key .**

Fig. 7

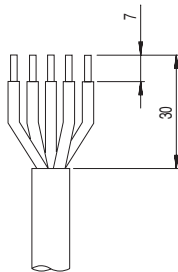
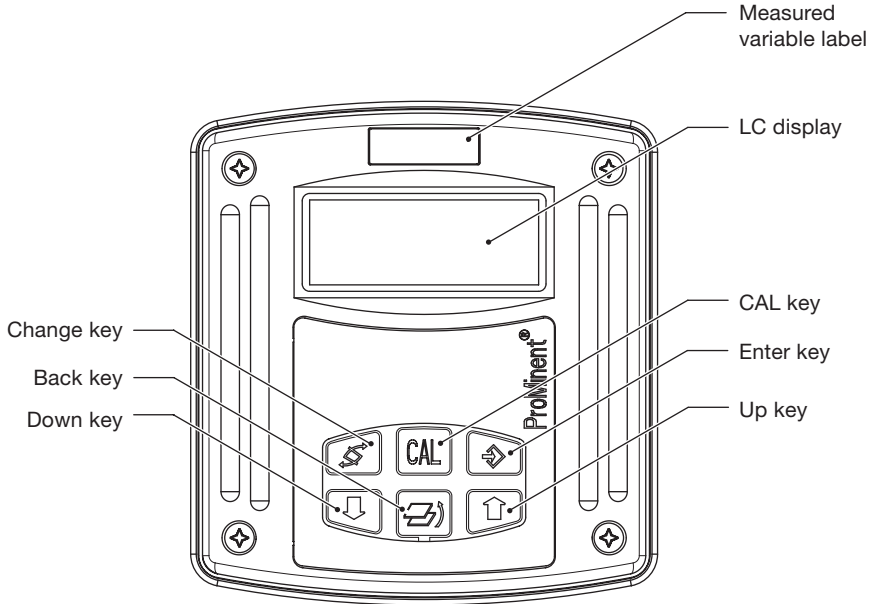

Fig. 8

pH/ORP	Cl/Cl ₂ /O ₂	
liquid pot.	1 (blk)-U	
---	2 (bl) +U	
ref.el.	3 ---	
glass el.	4 (br) meas.sig.	
Pt100 +	5 (with) Pt1000 +	4to20mA ⁺ 7
Pt100 -	6 (gr) Pt1000 - /sig.gnd.	- 8

5 Device overview and control elements

Fig. 9



3456_4

6 Function description

6.1 General

The DULCOMETER® MEASUREMENT TRANSDUCER (DMT) is a micro-processor controlled on site measurement transducer. It displays the selected measured variable and produces a proportional output signal. It can also use temperature as a correction variable. The user can specify these functions using the operating menu.

The inputs are collectively electrically insulated against the output.

In the event of a fault the DMT indicates an error message on the LC display and produces an increased current (23 mA) through the ring circuit.

The DMT is also available for the following measured variables:





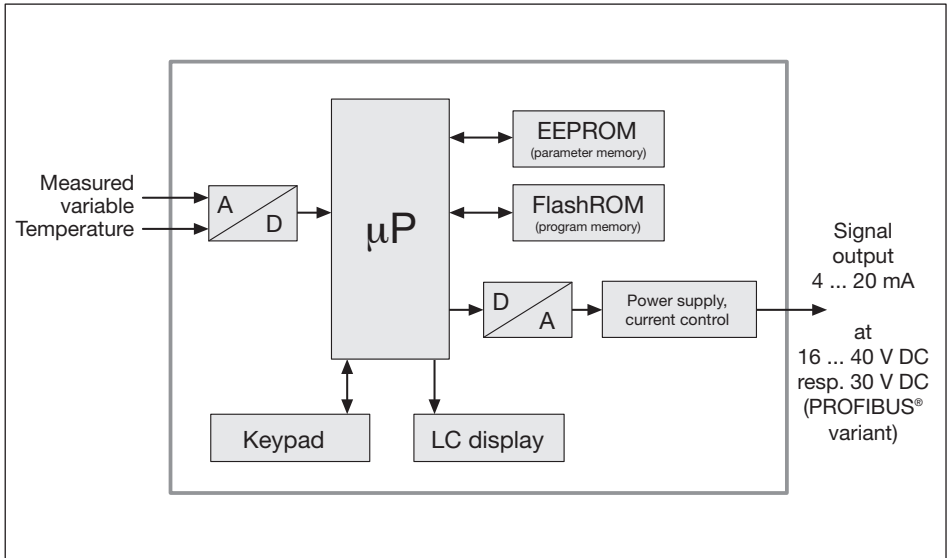

- Conductivity
- pH
- Redox
- Temperature

Block circuit diagram



6.2 Key functions

The key are used to alter the DMT settings and have the following functions:

	in the permanent display/ in the info display	in the menu options
Change key 	Toggles between permanent display and info display modes	Toggles between individual values that can be changed in the selected menu option
Back key 	Exits info display mode and returns to permanent display mode	Returns to info display without saving changes
Enter key 	Change to menu options (from an info display)	Saves changes to values in current menu option and accesses the next info display or another menu option
CAL key 	Opens the calibration menu (from permanent display)	Activates calibration in calibration menu (pH only)
Down key  Up key 	Alters brightness of the LC display (in permanent display mode)	Change a value

6.3 Operating menu, schematic

The operating menu comprises:

- **the permanent display**
- **the calibration menu**
- **the info displays** (info level)
for the display of pre-set parameters resp. general settings
- **menu options** (settings level)
for altering parameters resp. general settings

Function description

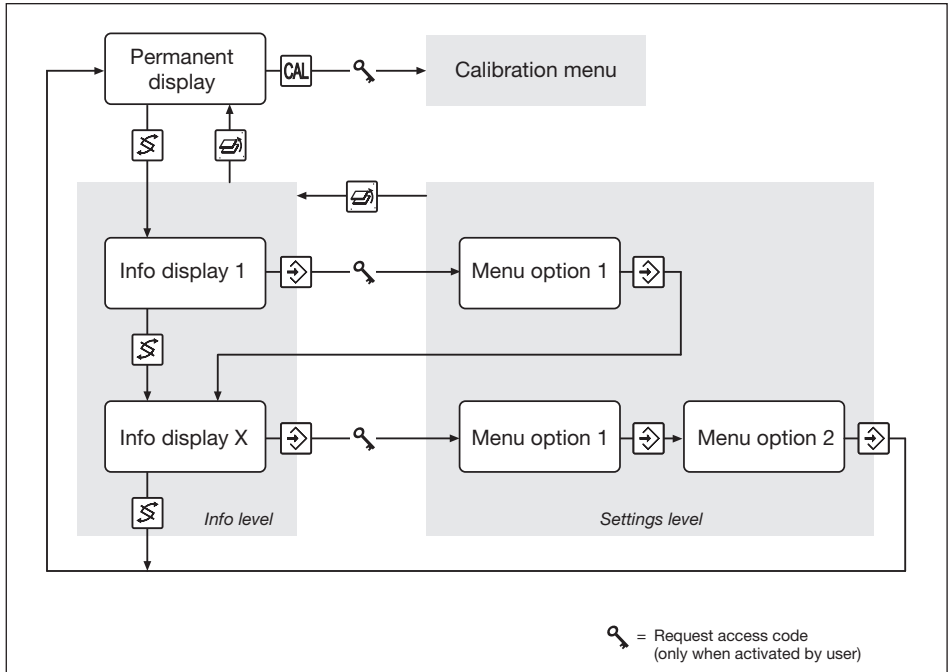

6.4 Negotiating operating menu

NOTE

- The back key can be used to exit the operating menu at any time. Depending upon where you are in the operating menu, you will return either to the permanent display or to the corresponding info level.
- The display will automatically return to permanent display if you do not press a key within 5 min. (does not save changes to values).
- If an access code has been activated by the user, access code protection is applied to both the calibration menu and the settings level menu options. To access these menu options the access code must be entered when it is requested and confirmed with the enter key . Access restriction is reinstated each time you return to the permanent display.
- The access code is factory set to 5000 (inactive).

6.4.1 Calibration menu

Access the calibration menu from the permanent menu using the CAL key  (further details given in 8.2 Calibration).

6.4.2 Info Display

Access the first info display of the info level from the permanent display using the change key .



Use the change key  to access the other info displays in turn. Returns to the permanent display after the last info display.

6.4.3 Menu options

Use the enter key  to access the menu options associated with that info level.

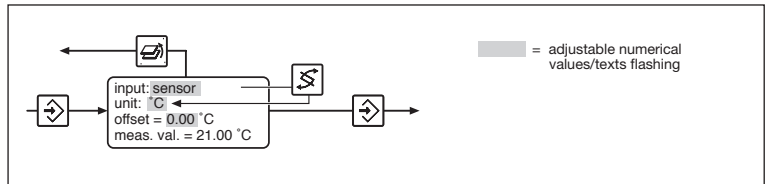
6.4.4 Negotiating the menu options



Press the change key  to activate all adjustable values in a menu option. Flashing values can be altered. Use the arrow keys  /  to alter numerical values or texts.

Keystrokes perform the following actions:

- 1 x short keystroke reduces/increases a numerical value by one increment or alters a text
- Holding the key down for longer alters numerical values increasingly rapidly.

Use the enter key  to save changed values in the menu option. You will then automatically enter the next info display or (if available) the next menu option.

NOTE

Your entries become active immediately and are stored permanently when you press the enter key .

If you do not wish to save changes, exit the menu option using the back key . You will then return to the info display for that menu.

7 DMT settings

NOTE

- Settings need only be changed if your process requirements differ from factory general settings.
- If your DMT does not display the required settings option, check the general settings of your device as described in chapter 7.1.5.

Menu overview table

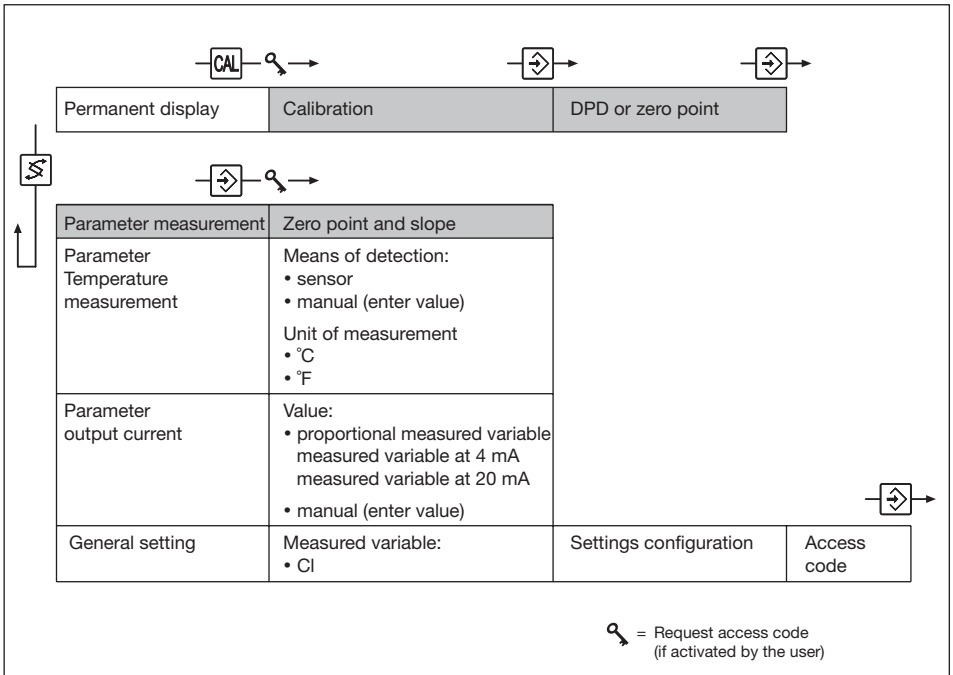

7.1 Measured variable chlorine

7.1.1 Menu overview measured variable chlorine

NOTE

The following menu is only an example.

The displays can vary depending upon the general settings.

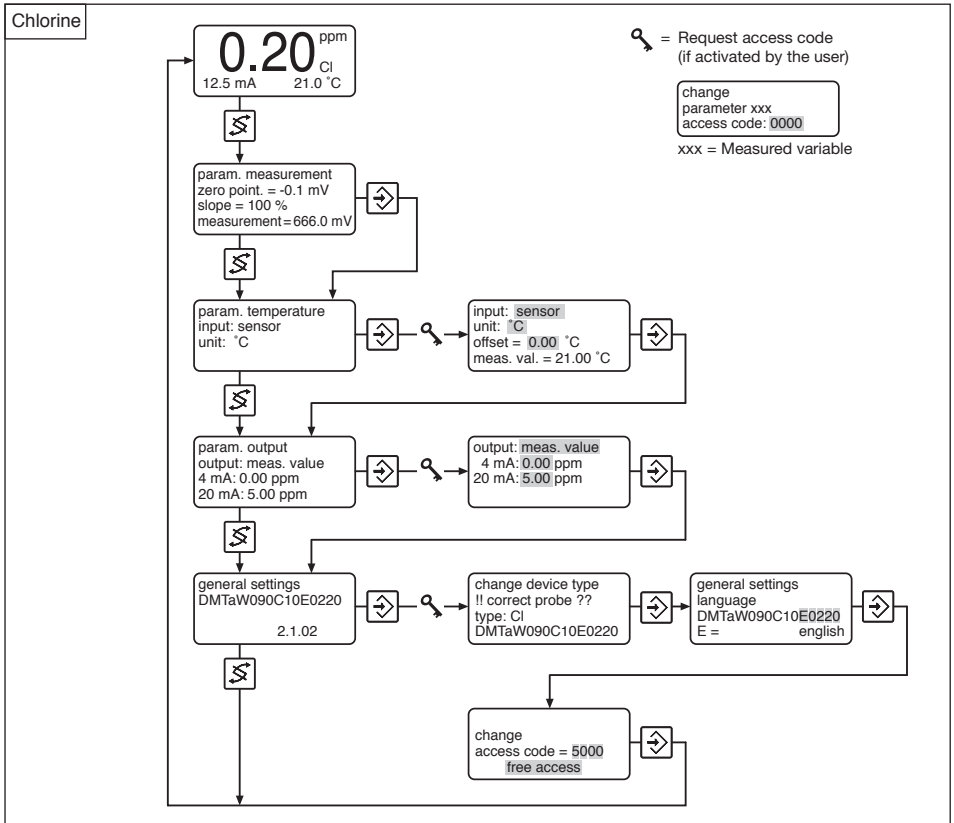

7.1.2 Parameter measurement

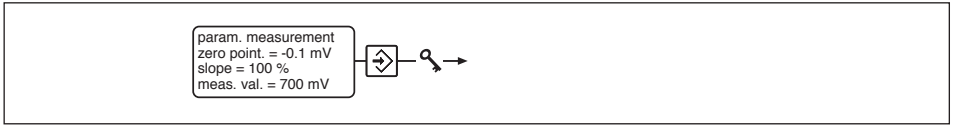

The following settings options are available to you:

- Zero point* ▶ Enter the calibration value under “Zero point” if these have been obtained by other means than via DMT calibration menu. The current concentration is displayed under “Measured value” for monitoring purposes.

7.1.3 Parameter temperature

NOTE

- *The DMT automatically detects whether a Pt 1000 or Pt 100 is connected.*

Depending upon the “Temp. meas.” general setting you have the following options:

7.1.3.1 General setting: Temperature measurement = automatic (= 0 in the identity code)

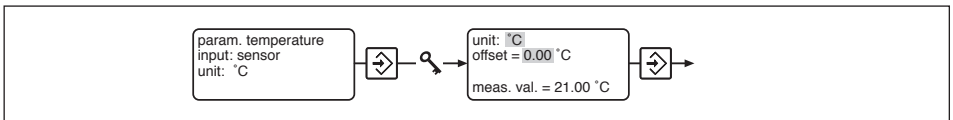

- ▶ Select the unit of measurement for temperature °C or °F under “Unit”.
- ▶ Enter the difference Δt under “Offset” to a reference temperature measurement (see chapter 7.1.3.5 Calibrating the Pt 100 temperature gauge).

The actual temperature measured is displayed under “Measured val.”.

7.1.3.2 General setting: Temperature measurement = manual (= 1 in the identity code)

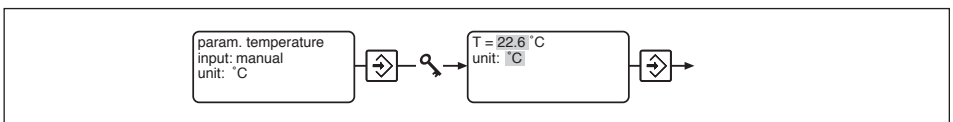

- ▶ Enter the process temperature under “T”.
- ▶ Select the temperature unit °C or °F under “Unit”.

7.1.3.3 General setting: Temperature measurement = automatic or manual (= 2 in the identity code)

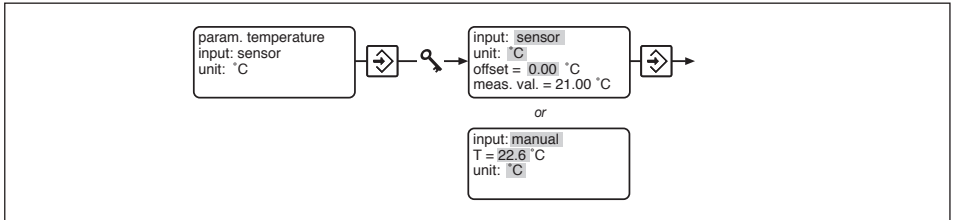

- ▶ Under “Input” select **sensor** or **manual**:
Select **sensor** if detecting temperature with a sensor (Temperature measurement = automatic);
Select **manual** if the user is going to enter the process temperature (Temperature measurement = manual).

The selection made under “Input” affects subsequent settings options.

Sensor If you have selected **sensor** in the “Input” option:

- ▶ Select the unit of measurement for temperature °C or °F under “Unit”.
- ▶ Enter the difference Δt under “Offset” to a reference temperature measurement (see 7.1.3.4 Calibrating the Pt 100 temperature gauge).

The actual temperature measured is displayed under “Measured val.”.

Manual If you have selected **manual** in the “Input” option:

- ▶ Enter the process temperature under “T”.
- ▶ Select the temperature unit °C or °F under “Unit”.

7.1.3.4 Calibrating the Pt 100 temperature gauge

NOTE

You need only calibrate the temperature gauge if

- *you have a Pt 100 temperature gauge and the sensor cable is longer than 4 m.*
 - *you have a precision measurement device (the DMT measures to $\pm 0,5$ °C / $\pm 0,9$ °F accuracy).*
- ▶ Immerse the DMT temperature gauge and the reference measurement device into the same liquid sample.
 - ▶ Read off the value from the reference measurement device once the temperature is stable.
 - ▶ Set the correction value “Offset” until the temperature value is identical to the reference value.

7.1.4 Parameter output

Depending upon the “Output” general setting you have the following settings options:

7.1.4.1 General setting: output current = measured value (= 0 in the identity code)

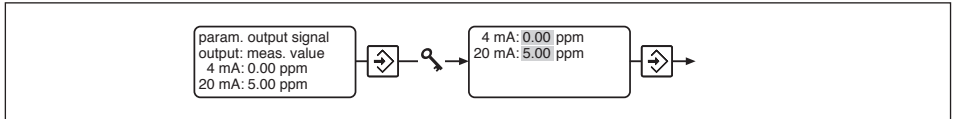

- ▶ Under “4 mA” enter the value at which the output current should be 4 mA.
- ▶ Under “20 mA” enter the value at which the output current should be 20 mA.

During calibration the output current increases to 23 mA.

7.1.4.2 General setting: output current = adjustable (= 1 in the identity code)

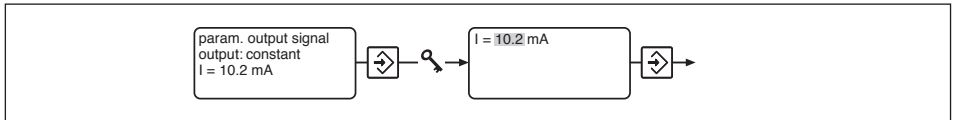

- ▶ Enter under “I” any output current between 4 and 20 mA.

This setting serves as a function check.

7.1.4.3 General setting: output current = measured value or adjustable (= 2 in the identity code)

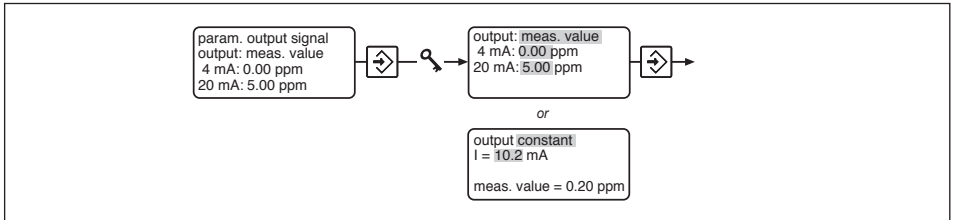

- ▶ Under “Output” select **meas. value** or **constant**:
Select **meas. value** if you require the output current to be proportional to the measured value (output = measured val.);
Select **constant** if you are going to enter the output current manually (output = manual).

The “Output” selection affects subsequent settings options:

Measured value If you have selected **meas. value** under “Output”:

- ▶ Under “4 mA” enter the value at which the output current should be 4 mA.
- ▶ Under “20 mA” enter the value at which the output current should be 20 mA.

During calibration the output current increases to 23 mA.

Constant If you have selected **constant** under “Output”:

- ▶ Enter under “I” any output current between 4 and 20 mA.

The current concentration is displayed under “Measured value” for monitoring purposes.

This setting serves as a function check.

7.1.4.4 General setting: output current = measured value + adjustable + HOLD (= 3 in the identity code)

In this general setting, the DMT can be adjusted as shown in 7.1.4.1 or 7.1.4.3.

In the case of the DMT the output current is retained during the calibration at the last output current value (HOLD-function). The output current is frozen at the moment the CAL button is pressed. This output current corresponds to the last measured concentration. The HOLD value for the output current is held until calibration is complete. It is also possible to set a predetermined HOLD value in the first option in the calibration menu (see 8.2.1).

7.1.4.5 General setting: output = 4 mA (= 4 in the identity code)

No info display appears in the operating menu.

The DMT emits a constant output current of 4 mA.

This setting serves as a function check and is selected if the DMT is to be used purely as a display device (current consumption is minimal in this case!)

7.1.5 General settings

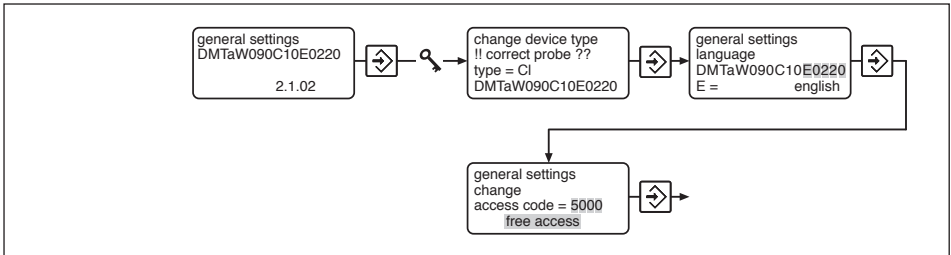

7.1.5.1 Changing the device type

For devices with more than one measured variable, you can select the measured variable in the first menu option “Device type”.

7.1.5.2 Changing general settings

You can adapt the DMT to your individual process requirements in the second menu option “general settings”.

Access the individual identity code positions using the change key . Non-alterable features are automatically bypassed.

The following tables show the settings options depending upon the selected measured value (the sequence from left to right corresponds to the identity code position).



IMPORTANT

If you change the sensor type, all numerical values and calibration values set in the operating menu are lost!

Measured variable chlorine				
Language (Language)*	Sensor type (Chlorine sensor type)*	Temperature measurement (Temperature measurement)*	Output current (Output)*	Other settings (Other settings)*
D = German E = English F = French S = Spanish I = Italian	0 = CLE 5 ppm 4 = CTE 10 ppm 5 = CLE 50 ppm	0 = automatic 1 = manual 2 = automatic or manual	0 = measured variable; fault 23 mA, calibration 23 mA 1 = manually adjustable current value 2 = measured variable or manual; fault 23 mA, calibration 23 mA 3 = measured variable or manual; fault 23 mA, when calibrating the last measured value (HOLD) 4 = constant 4 mA current	0 = standard

* Identity code text

7.1.5.3 Changing access code

The factory pre-set access code is **5000**. This setting allows unlimited access to the calibration menu and the menu options in the settings level.

This code can be changed in the third menu option "Change access code". Use the change key  to move to individual digits.

The new code is confirmed and activated with the enter key .

NOTE

- ***If an access code has been activated by the user, access code protection is applied to both the calibration menu and the settings level menu options. To access these menu options the access code must be entered when it is requested and confirmed with the enter key. Access restriction is reinstated each time you return to the permanent display.***
- ***To deactivate the access code, reset to 5000 in the "Change access code" menu.***
- ***Inadmissible access codes are: 0000, 1111, 2222, ..., 9999 and 1234.***

8 Operating the DMT

8.1 Permanent display

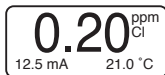



The permanent display allows you to monitor the DMT measured variables during operation.

The permanent display can indicate the following (depending upon general settings):

- Measured variable
- Correction variable
- Output current
- Manual settings
- Error messages

8.1.1 Brightness of LC display

You can alter the brightness of the LC display in the permanent display:

- ▶ Increase brightness using the down arrow key  or reduce using the up arrow key .

8.2 Calibration

The condition of the sensor is a key factor in the quality of the measurement. The sensor must therefore be re-calibrated at regular intervals with the aid of a DPD measurement kit.

8.2.1 Calibration process



IMPORTANT

You must read the chapter “Calibration” from the operating instructions for the DMT chlorine sensors!

NOTE

- *The back key  can be used to exit the calibration menu at any time. You will then return to the permanent display.*
- *The output current is frozen for the duration of the calibration at, depending upon general settings, the last measured value (HOLD) or at 23 mA (see chapter 7.1.5 General settings).*
- *Inadmissible values render the ongoing calibration invalid. The error messages are explained in chapter 9.2.*

Calibration menu overview

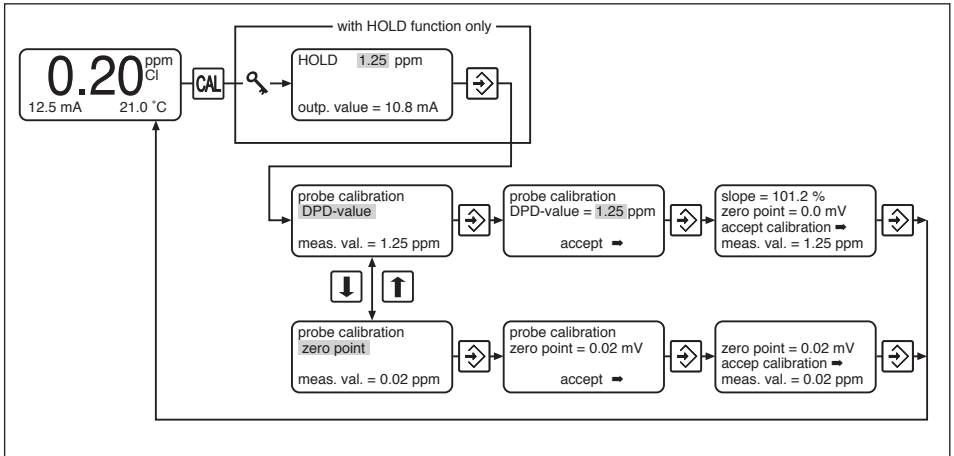

Proceed as follows to call up the calibration menu:

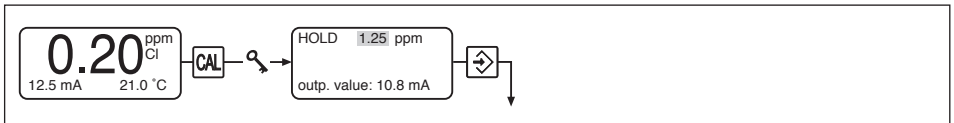

Starting calibration

- ▶ Press the CAL-key **CAL** while in permanent display mode while the sensor is immersed in the sample water.

If the HOLD function has been activated (see “General settings”, 7.7.2) you can:

Change the HOLD value under “HOLD”.
This setting is only valid during calibration.

The next steps depend on whether you are calibrating the DPD value or require a zero point calibration:

Calibration via DPD value

- Press the Enter key to access the “Calibrate sensor” menu.
- Press the Enter again to access the second “Calibrate sensor” menu option.
- Determine the chlorine content in the sample water using a DPD-kit.
- Enter the chlorine content with the arrow keys.
- Press the Enter key to return to the previous menu option.
- Continue as described under “Conclude calibration”.

Zero point calibration

NOTE

This section is to be used with the “Zero point calibration” in the DMT sensor operating instructions.

Please proceed according to the section for the sensor.

Press the Enter key to access the “Calibrate sensor” menu.

Press the Enter key again to access the second “Calibrate sensor” menu option.

Use the arrow keys to select “Zero point” instead of “DPD value”.

Press the Enter key again to return to the “calibrate sensor” menu option.

The current zero point is displayed under “Zero point”.

Press the enter key to return to the previous menu option.



- ▶ Continue as described under “Conclude calibration”.

Conclude calibration

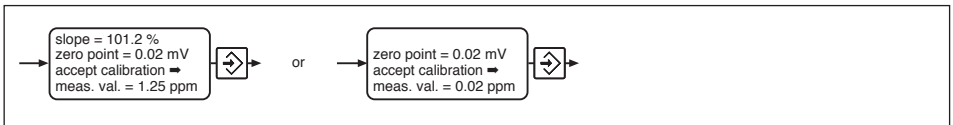
The calibration values (zero point and slope) are now displayed:



The current concentration is shown under “measured val.”.

- ▶ Press the enter key  to adopt the values or the back key  to exit without saving the values.

The display changes to permanent display. The calibration is complete.

NOTE

Inadmissible values render the current calibration process invalid.

The error messages during calibration are explained in chapter 9.2.

9 Troubleshooting

9.1 Error messages during operation

The following error messages can appear in the permanent display during operation:

Message	Displayed value	Cause of fault	Remedy
Output overflow	Measured value	Warning: detected current value <i>greater</i> than pre-set 20 mA value	Change configuration if necessary
Output underflow	Measured value	Warning: detected current value <i>less</i> than pre-set 4 mA value	Change configuration if necessary
Sensor signal above max. value		Input voltage >1100 mV Faulty power connection or faulty sensor or non suitable sensor.	Check connection Replace sensor Use sensor with wider measurement range.
Sensor signal below min. value		Input voltage <-100 mV Faulty connection or incorrect sensor in the run-in phase or sensor faulty	Check connection Service sensor Replace sensor
Temp. input error!	999.9 °	Sensor not present or lead damaged	Check sensor connection (set temperature measurement to manual if necessary)
Temp. input error!	-99.9 °	Short circuit	Check sensor connection (set temperature measurement to manual if necessary)

The error message disappears automatically once you have remedied the fault.

9.2 Error messages during calibration

The following error messages can appear in the corresponding menu options during calibration:

Message	Condition	Effect
DPD value too low!!!	Value < 1 % range	DPD value not adopted
Zero point too high!!!	-15 mV > N > 15 mV	Zero point not adopted, Warning: "Recalibrate zero point"
Slope < 25%!!!	S < 25 %	Slope adopted
Calibr. invalid !!! Slope < 25%!!!	S < 10 %	Slope not adopted
Slope > 400% !!!	S > 400 %	Slope adopted
Calibr. invalid !!! Slope > 400% !!!	S > 1000 %	Slope not adopted

* The admissible setting time is: $t_{\text{cal}} < 60 \text{ s}$ for a value fluctuation $\Delta U < 2 \text{ mV/s}$

10 Maintenance and repair

Maintenance The DMT requires no maintenance.
You should clean the housing with a damp, soapy cloth and then rub dry.



IMPORTANT

Solvents may attack the surfaces and should not be used.

Repair Please return the DMT to ProMinent Dosiertechnik GmbH for repair.

11 Disposal



IMPORTANT

Please observe the applicable national regulations.

You may return the decontaminated used equipment to
ProMinent Dosiertechnik GmbH, Heidelberg, against prepaif postage.

12 Technical Data

Electrical data

<i>Device</i>	Protection class:	III
	Supply voltage:	- 4-20 mA (two wire) current loop, 24 V DC (16...40 V DC), protective low voltage - PROFIBUS®-DP, 24 V DC (16...30 V DC), protective low voltage The supply voltage level must not fall below 16 V at any time.
	Signal output:	4 ... 20 mA in normal operation, 23 mA to signal fault Ohmic resistance 50 Ω

Enclosure ratings

When installed correctly the following enclosure ratings apply:	
Wall/pipe mounted:	IP 65 in accordance with DIN VDE 0470-1
Control panel mounted:	IP 54 in accordance with DIN VDE 0470-1

Measured variable

Measurement range:	0 ... 1000 mV at input terminals Measured range of concentration depends on sensor
Reproducibility:	10 µV ... 100 µV depending on measured value
Operating measurement deviation:	max. 0,2 mV at 25 °C ambient temperature
Insulation voltage:	500 VDC; electrically insulated against ring circuit
Input resistance:	> 10 ¹² Ω
Sensor power supply:	3.3 V/500 µA
Resolution:	10 µV ... 100 µV depending on measured value

Measured variable/ Correction variable temperature

Measurement range:	-20 °C ... 150 °C, -4 °F ... 302 °F
Measurement deviation:	max. 0.3 °C (Pt 1000 at 25 °C ambient temperature) max. 0.5 °C (Pt 100 at 25 °C ambient temperature)
Resolution:	0.1 °C

Display

Principle:	LCD (liquid crystal display)
------------	------------------------------

Ambient conditions

Operating temperature:	0 ... 55 °C
Storage temperature:	-20 ... 70 °C
Air humidity:	max. 95 % rel. humidity, non condensing

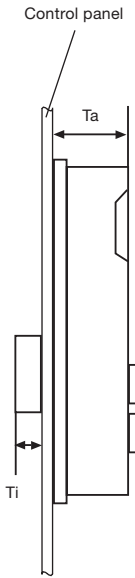

DMT-Dimensions

Dimensions and weight

Dimensions:	Wall/pipe mounted version 126x136x78 mm (WxHxD) Panel mounted version 35 mm, 30 mm (T_i , T_a)
Weight:	Wall mounted, 450 g Panel mounted, 300 g
Admissible cable diameters:	M 20 x 1.5 Terminal area \varnothing 5 ... \varnothing 10 mm (SW 22) M 16 x 1.5 Terminal area \varnothing 2 ... \varnothing 7 mm (SW 19)
Admissible lead cross sections:	0.14 ... 0.75 mm ²
Admissible screen diameters:	\varnothing 2 ... \varnothing 5 mm

Material information

Housing:	PPE-GF10
Wall/pipe bracket:	PPE-GF20
Keypad:	Silicon
Housing seal:	Silicon

13 Spare parts and accessories

Assembly kit for wall/pipe mounting	Part no. 1003205
Pipe clamps for pipe mounting	Part no. 1002777
Chlorine sensors, Pt 100/Pt 1000	see product catalogue
Sensor cable	see product catalogue

NOTE

Please give the identity code when ordering electronic component kits.

EC Declaration of Conformity

We,

**ProMinent Dosiertechnik GmbH
Im Schuhmachergewann 5 - 11
D - 69123 Heidelberg**

hereby declare that, on the basis of its functional concept and design and in the version brought into circulation by us, the product specified in the following complies with the relevant, fundamental safety and health stipulations laid down by EC regulations.

Any modification to the product not approved by us will invalidate this declaration.

Product description : *Dulcometer transducer*

Product type : *DMTa*

Serial number : *see type identification plate on device*

Relevant EC directives : *EC - EMC - directive (2004/108/EC)*

Harmonised standards used,
in particular : *EN 55011, EN 61000-6-1, EN 61000-6-2, EN 61000-6-3,
EN 61000-6-4*

Date/manufacturer's signature :

10.04.2007



The undersigned :

Dr. Johannes Hartfiel, assistant development manager

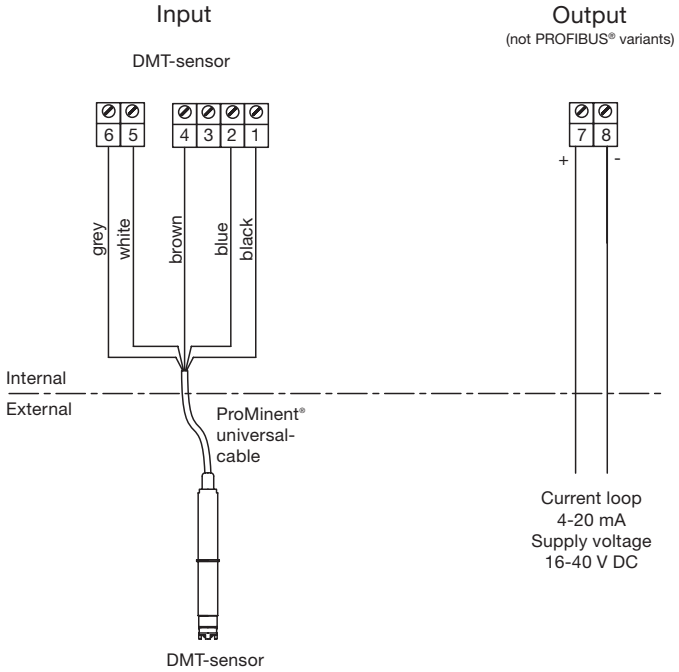

Wiring example - two wire system

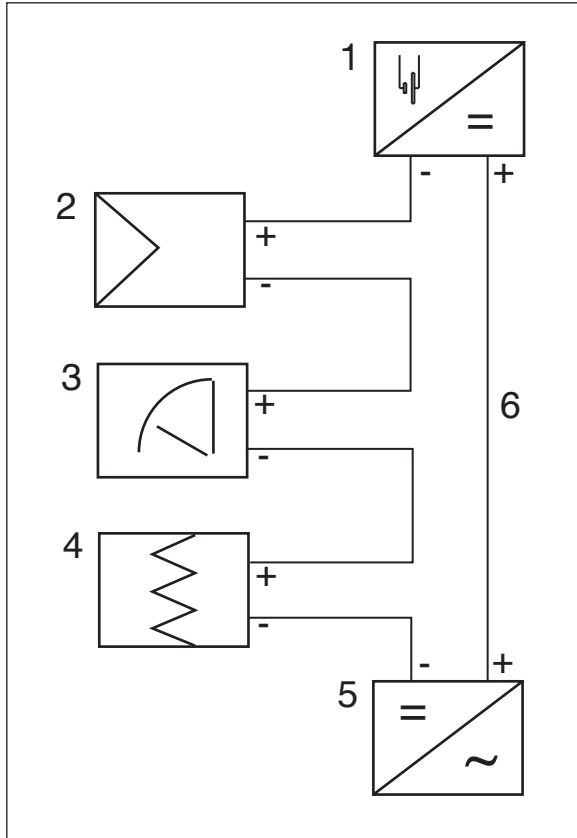

- 1 DMT transducer
- 2 Controller
- 3 Meter
- 4 Recorder
- 5 24 V DC (16...30 V DC/40 V DC) power supply unit
- 6 4-20 mA current loop



NOTE

- *The signal inputs of all devices in the current loop must be electrically isolated from the current output.*
- *Take into account the sum of the ohmic resistances of all devices in the current loop (excluding power supply).
The input voltage of the transducer must never drop below 16 V during operation.
The measured value will otherwise be wrong.*

PROFIBUS®-DMT power supply

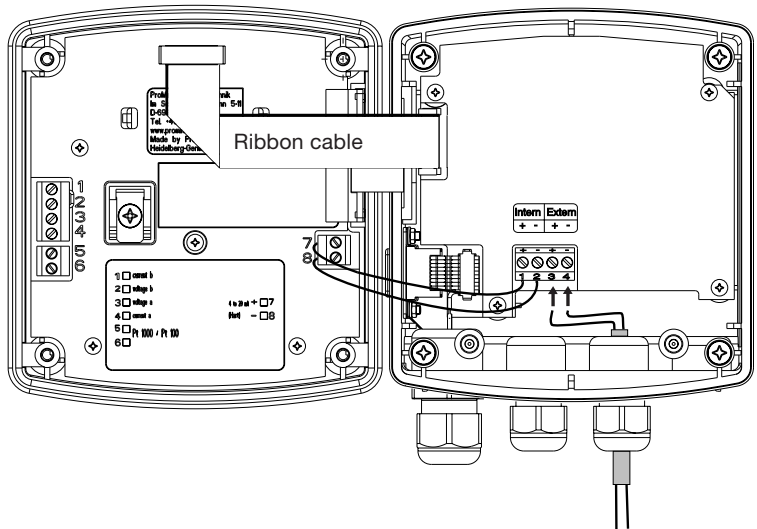

Supply voltage
16-30 V DC

NOTE

To operate the PROFIBUS®-DMT temporarily without the PROFIBUS®, unplug the ribbon cable (see fig.) and briefly disconnect from the power supply.

To operate the PROFIBUS®-DMT with the PROFIBUS® again, plug the ribbon cable back in (plug in the connector on the side of the PROFIBUS® circuit board with the red edge of the ribbon cable facing upwards, see fig.). Briefly disconnect from the power supply.

A

Access code 18, 27

C

Calibration

Error messages 32

Measurement 28

Pt 100 23

Calibration menu 29

Conformity declaration 36

D

Device type 26

E

Error messages

in operation 31

at calibration 32

F

Function check output 24, 25

G

General settings 26

change 26

H

HOLD function 25, 28, 29

I

Identity code

measured variable 5

Info display 17

Install 11

K

Key function 17

L

Language

General setting 26, 27

LC display

Brightness 28

M

Menu overview

Calibration menu 29

Measured variable 21

Table form 20

Menu option 19

Minimum current use 26

Mounting 8

O

Operating controls 15

Operation 28

Operating menu 21

schematic 17

Output

General setting 26, 27

Parameters 24

P

Parameters

Output 24

Measurement 22

Temperature 22

Permanent display 28

PROFIBUS® 16, 39

S

Settings 20

Setting sensor type 26

Slope 22, 29

T

Temperature

Parameters 22

Temperature measurement

General settings 26, 27

Terminal connection plan DMT 14, 37

PROFIBUS® circuit board 39

Troubleshooting 31

Two-wire technology 37

W

Wiring example-two wire system 38

Z

Zero point 22, 30

Drilling template for DMT

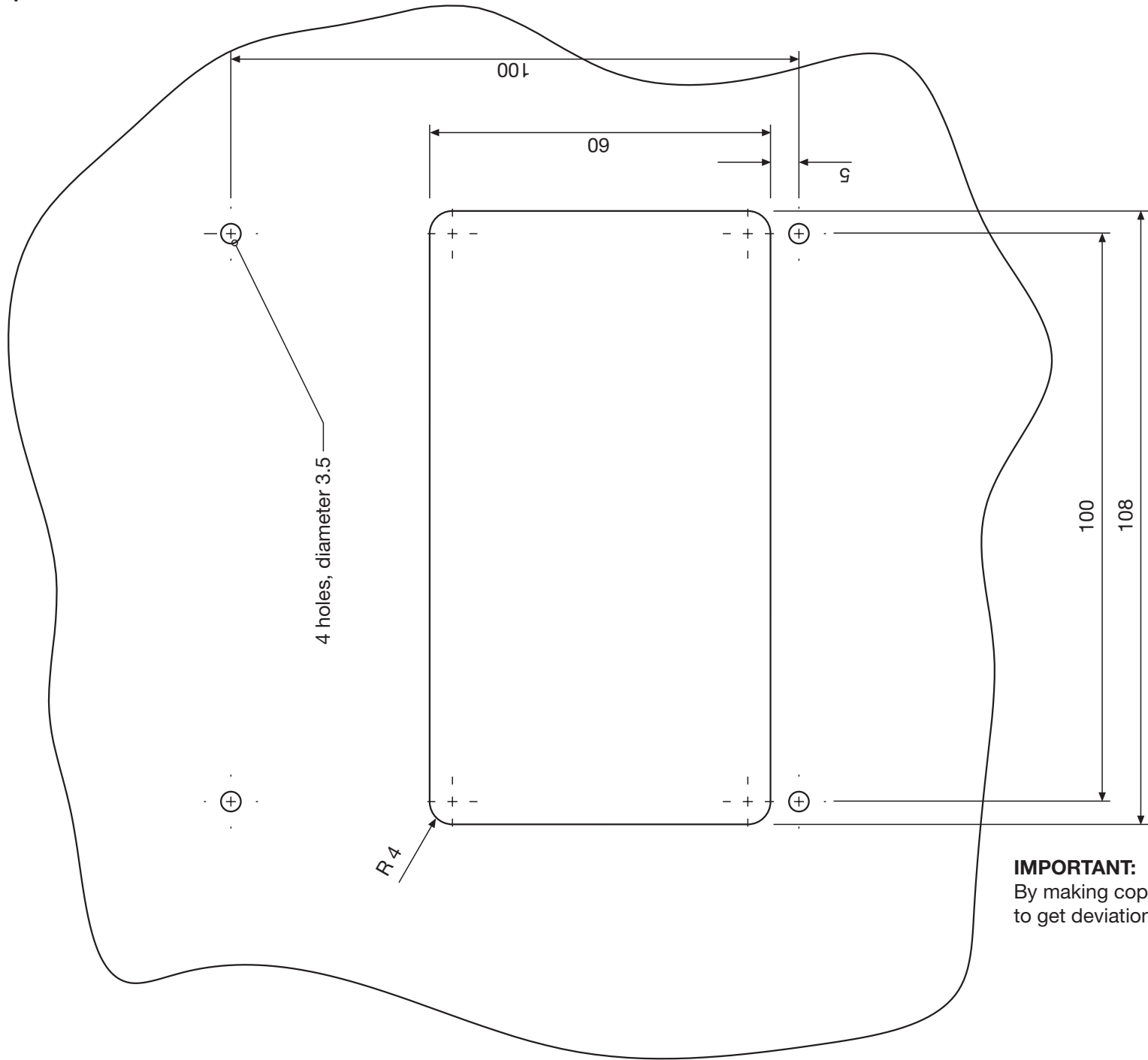

3460-4.1

IMPORTANT:
By making copies it's possible
to get deviations!



**Addresses and delivery information
from the manufacturer:**

ProMinent Dosiertechnik GmbH
Im Schuhmachergewann 5-11
69123 Heidelberg
Germany

Phone: +49 6221 842-0
Fax: +49 6221 842-419

info@prominent.com
www.prominent.com