

# KT08

## CARTRIDGE SOLENOID VALVE SERIES 10



### CARTRIDGE TYPE

seat 3/4-16 UNF-2B ISO 725

**p** max **350** bar

**Q** nom **50** l/min

### OPERATING PRINCIPLE

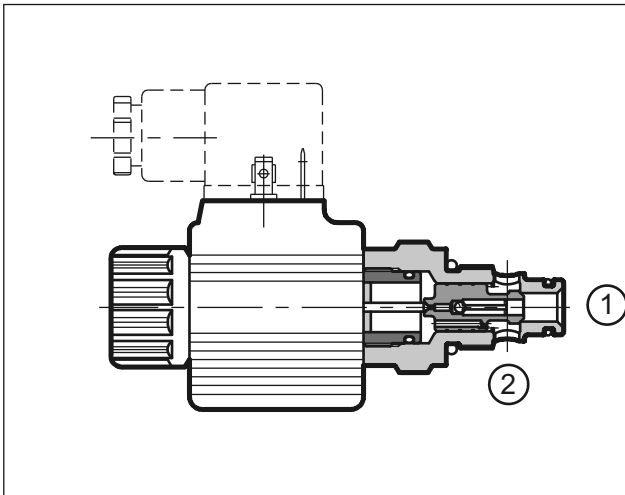

- The KT08 is a 2-ways solenoid valve, poppet type, cartridge execution, available in normally closed version (NC) and normally open version (NO) with nominal flow rate of 50 l/min.
- It ensures a low internal leakage, which decreases while the pressure increases.
- The valve can be ordered with direct current or rectified current solenoids and with five different types of electrical connections, in order to cover many installation requirements (see paragraph 8).
- For every version, the emergency manual override is an available option (see paragraph 7).

### PERFORMANCES (working with mineral oil of viscosity of 36 cSt at 50°C)

Maximum operating pressure	bar	350
Nominal flow rate	l/min	50
Pressure drops $\Delta p - Q$	see paragraph 3	
Electrical characteristics	see paragraph 5	
Electrical connections	see paragraph 8	
Ambient temperature range	°C	-20 / +50
Fluid temperature range	°C	-20 / +80
Fluid viscosity range	cSt	10 + 400
Fluid contamination degree	According to ISO 4406:1999 class 20/18/15	
Recommended viscosity	cSt	25
Mass	kg	0,32
Surface treatment with white colour zinc	Fe / Zn 8c 1B UNI ISO 2081/4520	

### HYDRAULIC SYMBOLS

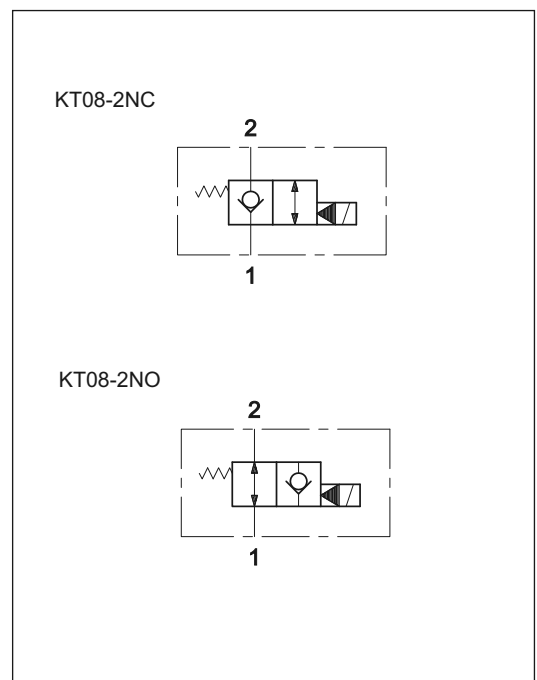

## 1 - IDENTIFICATION CODE

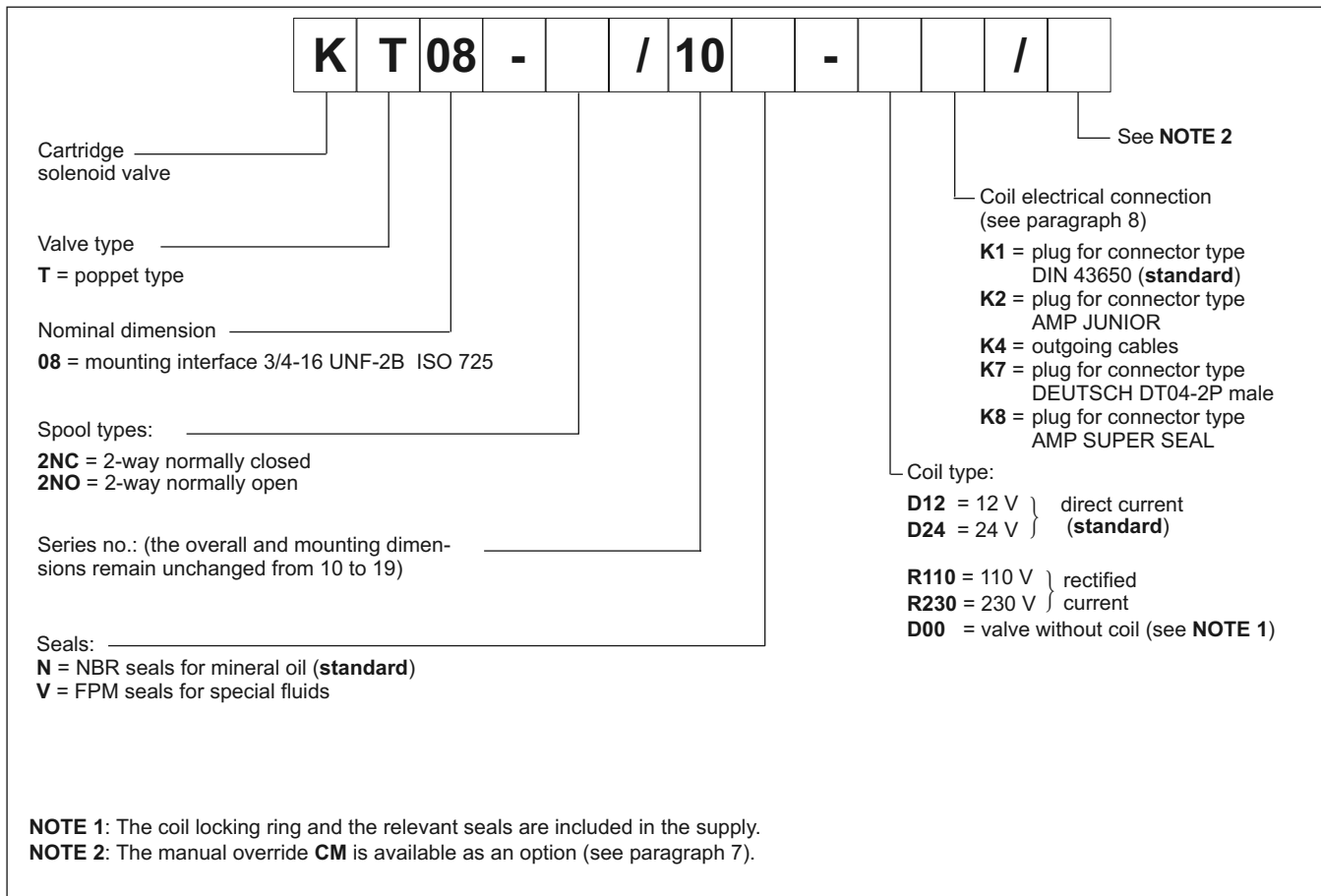

### 1.1 - Coil identification code

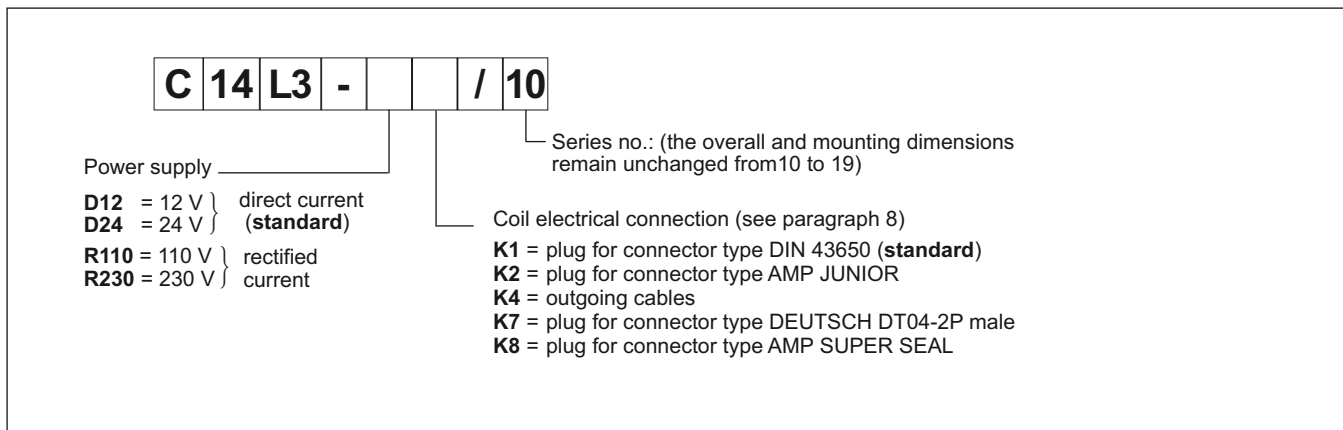

## 2 - HYDRAULIC FLUIDS

Use mineral oil-based hydraulic fluids HL or HM type, according to ISO 6743-4. For these fluids, use NBR seals (code N). For fluids HFDR type (phosphate esters) use FPM seals (code V). For the use of other fluid types such as HFA, HFB, HFC, please consult our technical department. Using fluids at temperatures higher than 80 °C causes a faster degradation of the fluid and of the seals characteristics. The fluid must be preserved in its physical and chemical characteristics.

### 3 - PRESSURE DROPS $\Delta p$ -Q (obtained with viscosity of 36 cSt at 50 °C)

The values in graphs refer to both NC and NO valves and they differ for the mounting interface used.

**standard mounting interface dimensions**  
3/4-16 UNF-2B ISO 725

dimensions in mm

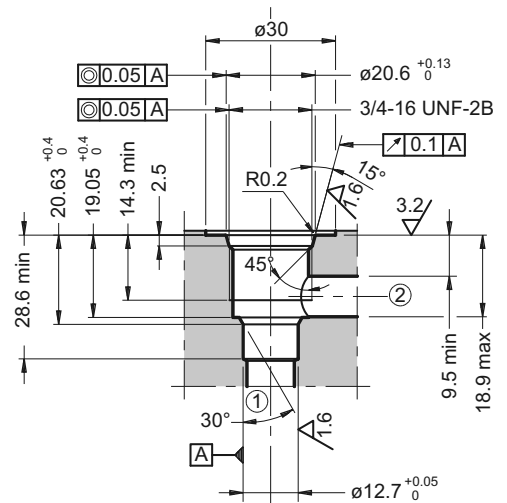
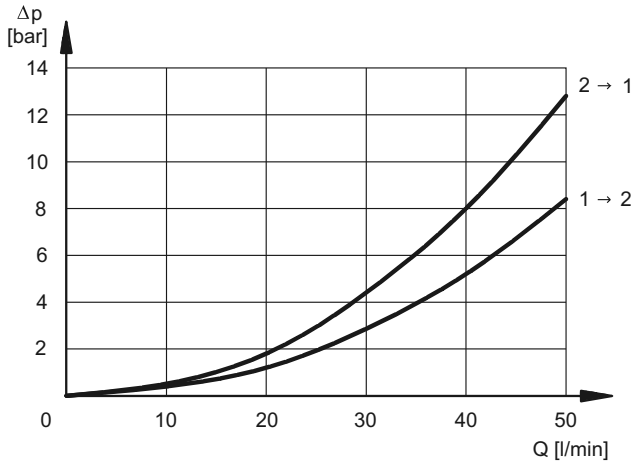

**oversize mounting interface dimensions**  
3/4-16 UNF-2B ISO 725

dimensions in mm

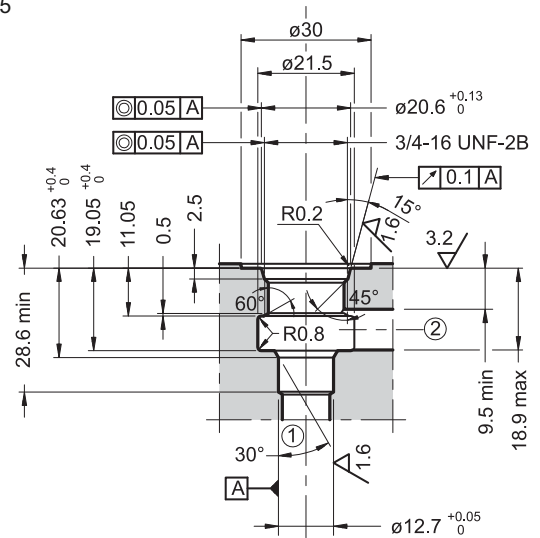
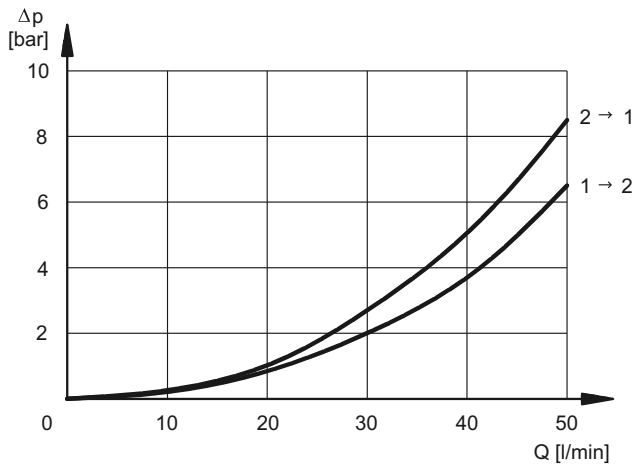

### 4 - SWITCHING TIMES

The values indicated refer to a valve tested with Q=25 l/min, p=350 bar, working with mineral oil at a temperature of 50°C and a viscosity of 36 cSt.

	TIMES (±10%)	
	ENERGIZING	DE-ENERGIZING
KT08-2NC	60 ms	85 ms
KT08-2NO	85 ms	60 ms

### 5 - ELECTRICAL FEATURES

#### 5.1 Solenoids

These are essentially made up of two parts: tube and coil. The tube is threaded onto the valve body and includes the armature that moves immersed in oil, without wear. The inner part, in contact with the oil in the return line, ensures heat dissipation. The coil is fastened to the tube by a threaded nut, and can be rotated according to the available space.

The interchangeability of coils of different voltages both D or R type is possible without removing the tube.

#### Protection according CEI EN 60529 - atmospheric agents

Connector	IP 65	IP 67	IP 69 K
K1 DIN 43650	x		
K2 AMP JUNIOR	x	x	
K4 outgoing cables	x	x	
K7 DEUTSCH DT04 male	x	x	x
K8 AMP SUPER SEAL	x	x	x

**NOTE:** The protection degree is guaranteed only if the connector is correctly installed and locked.

<b>SUPPLY VOLTAGE FLUCTUATION</b>	± 10% Vnom
<b>MAX SWITCH ON FREQUENCY</b>	10.000 ins/hr
<b>DUTY CYCLE</b>	100%
<b>ELECTROMAGNETIC COMPATIBILITY (EMC)</b>	In compliance with 2004/108/CE
<b>LOW VOLTAGE</b>	In compliance with 2006/95/CE
<b>CLASS OF PROTECTION :</b> Coil insulation (VDE 0580) Impregnation	class H class H

#### 5.2 Current and absorbed power

In the table are shown current and power consumption values relevant to the different coil types. "R" coil must be used when the valve is fed with AC power supply subsequently rectified by means of rectifier bridge, externally or incorporated in the "D" type connector (see cat. 49 000).

	Resistance at 20°C [Ω] (±1%)	Absorbed current [A] (±5%)	Absorbed power (±5%)		Coil code				
			[W]	[VA]	K1	K2	K4	K7	K8
<b>C14L3-D12*</b>	5,4	2,2	26,5		1902740	1902750	1902770	1902980	1903020
<b>C14L3-D24*</b>	20,7	1,16	27,8		1902741	1902751	1902771	1902981	1903021
<b>C14L3-R110*</b>	363	0,25		27,2	1902742				
<b>C14L3-R230*</b>	1640	0,11		26,4	1902743				

### 6 - OVERALL AND MOUNTING DIMENSIONS

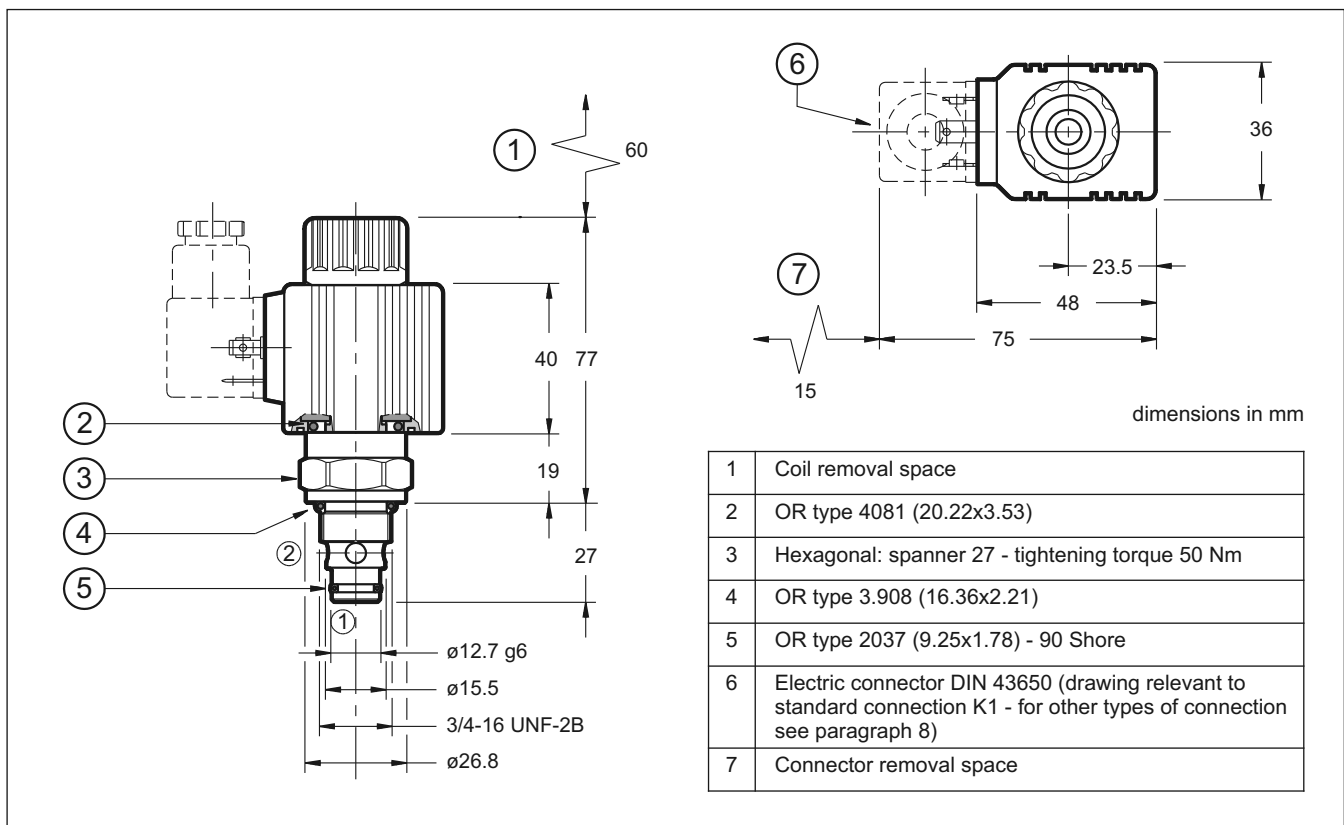

## 7 - MANUAL OVERRIDE

CM for NO version (pushing type)

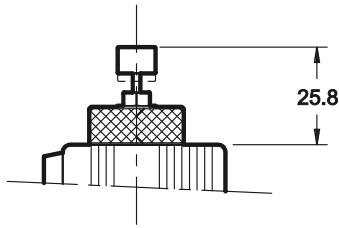

CM for NC version (screw type)

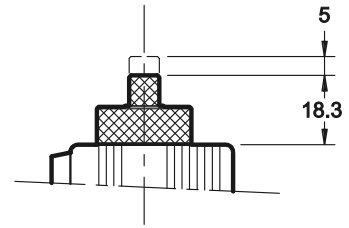

## 8 - ELECTRIC CONNECTIONS

connection for DIN 43650 connector  
code **K1 (standard)**

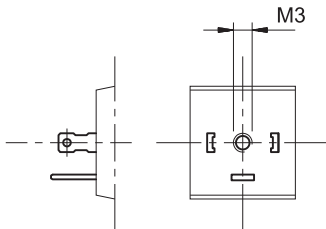

connection for AMP JUNIOR connector  
code **K2**

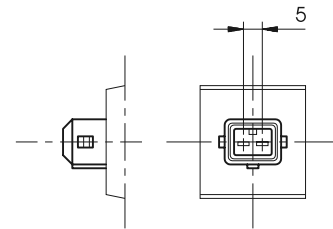

outgoing cables connection  
code **K4**

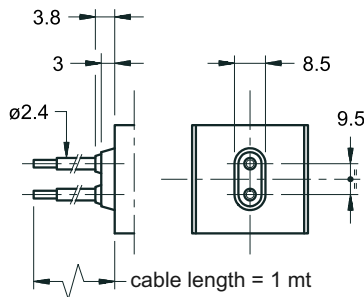

connection for DEUTSCH DT04-2P male connector  
code **K7**

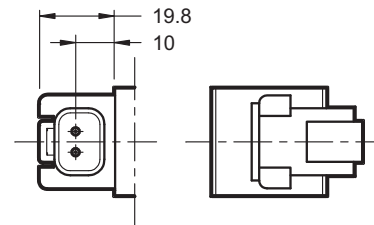

connection for AMP SUPER SEAL connector (two contacts)  
code **K8**

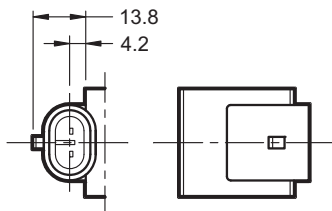

## 9 - ELECTRIC CONNECTORS

The solenoid valves are supplied without connectors. For coils with standard electrical connections K1 type (DIN 43650) the connectors can be ordered separately. For the identification of the connector type to be ordered please see catalog 49 000. For K2, K7 and K8 connection type the relative connectors are not available.



## 10 - SUBPLATES FOR MODULAR MOUNTING

### 10.1 - Identification code

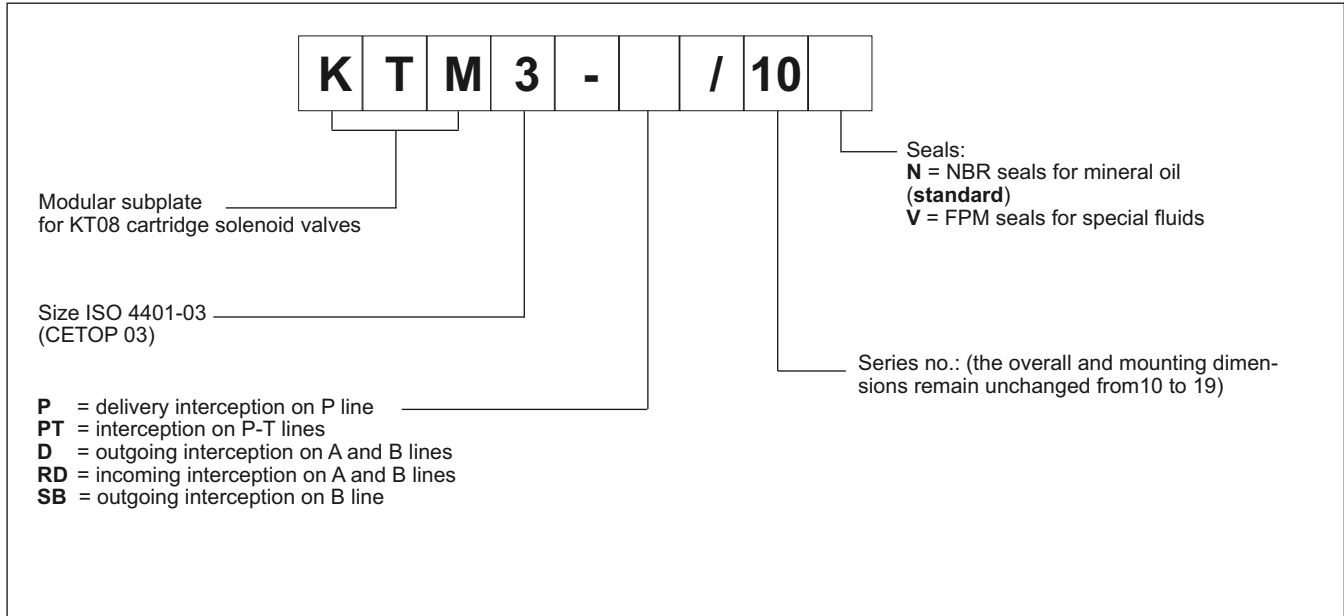

### MOUNTING INTERFACE

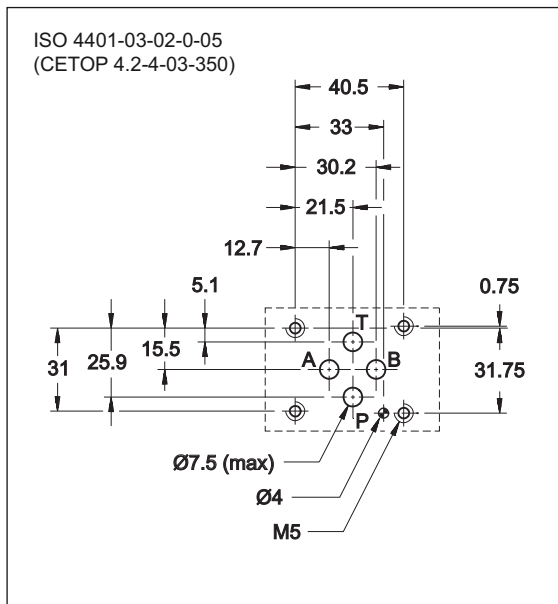

### HYDRAULIC SYMBOLS

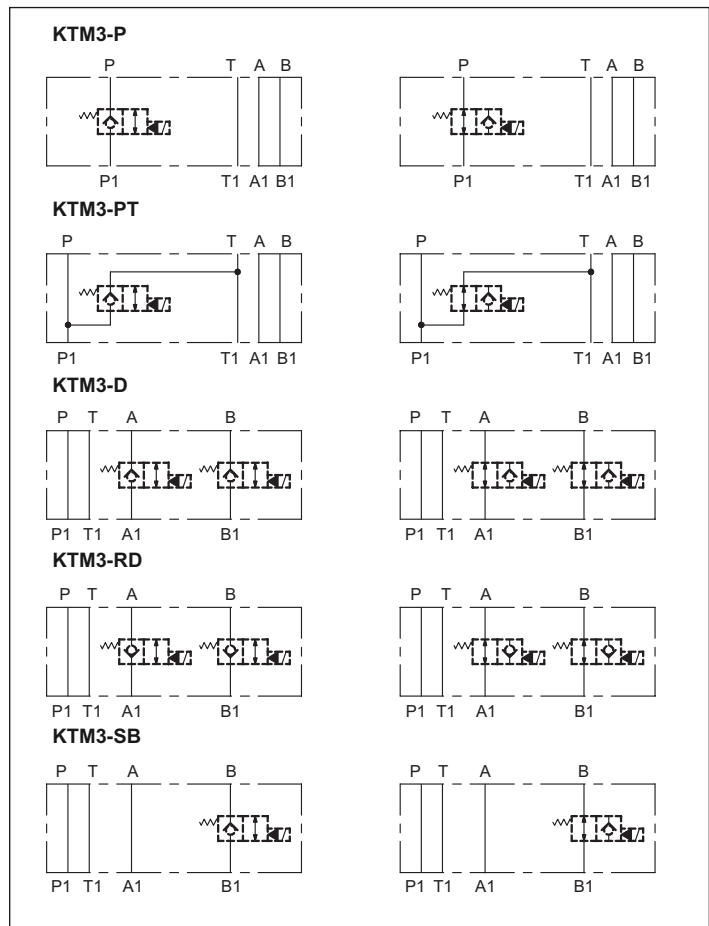

### 10.2 - Overall and mounting dimensions KTM3-P

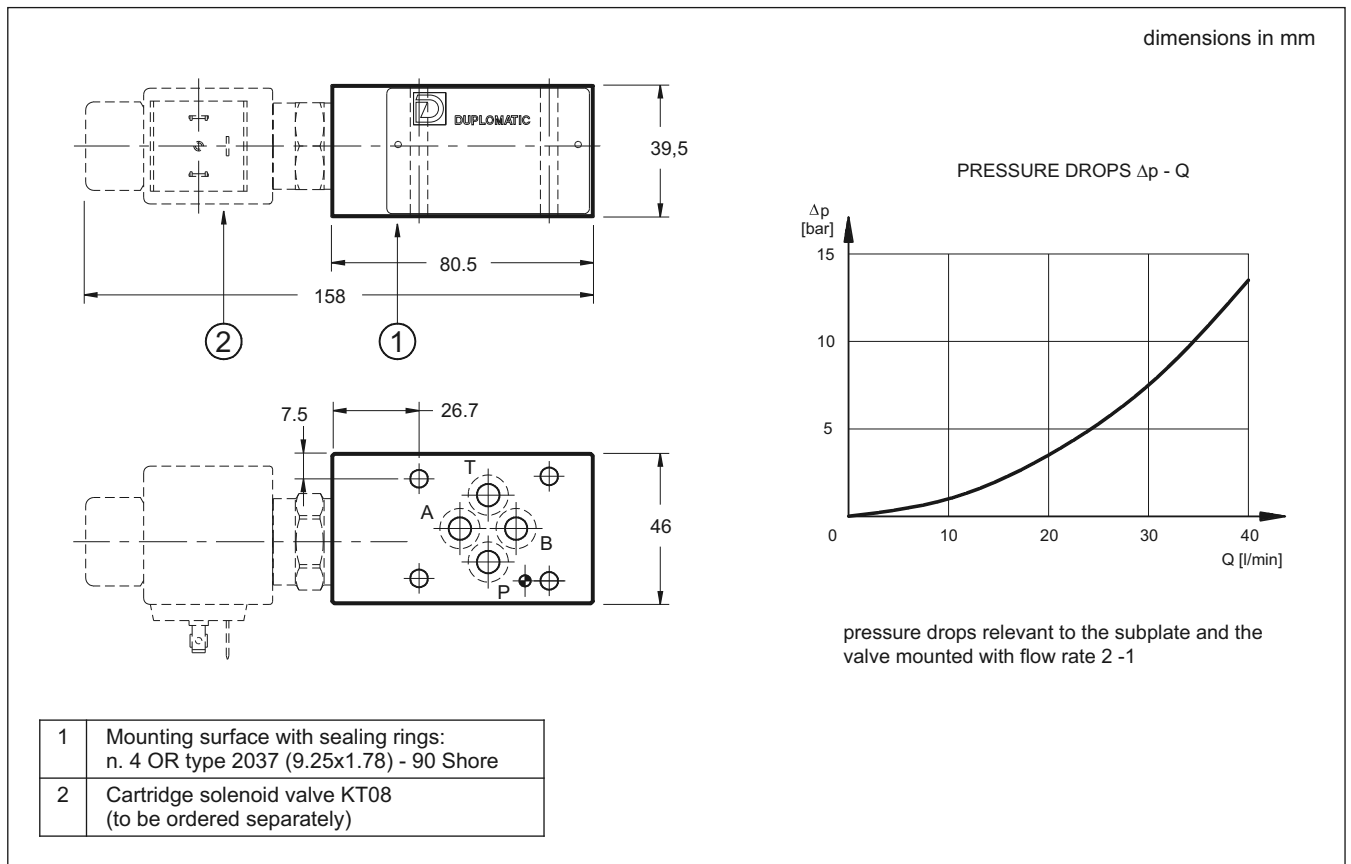

### 10.3 - Overall and mounting dimensions KTM3-PT

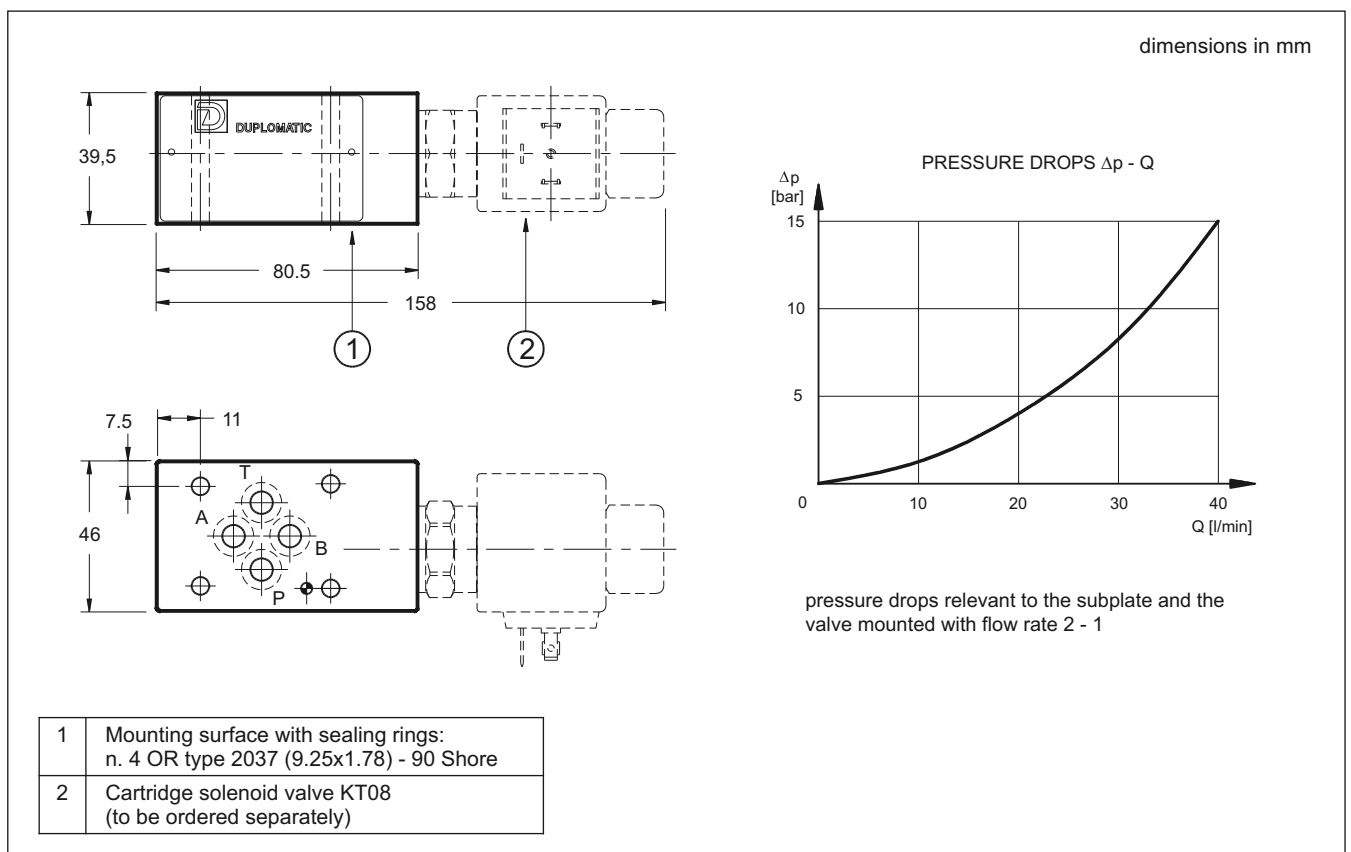

### 10.4 - Overall and mounting dimensions KTM3-D, KTM3-RD and KTM3-SB

