



SILENT AND POWERFUL MIXED FLOW EXTRACT FAN

APPLICATION

Ideal for air-extraction in bathroom, toilet and small/medium premises.
Suitable to extract stale air directly to the outside or through medium length ducting.
Unit is available in Ø100mm and can be wall/panel or ceiling mounted.

SPECIFICATION

Casing made of high quality ABS provides long lasting shock-proof and robust construction. The unit is finished in white RAL 9010 and are UV resistant.

High efficient impeller, providing enhanced aerodynamic properties, low noise and increased performances.

Single-phase induction motor with integral thermal protection.
Suitable for continuous and intermittent running.

FEATURES & BENEFITS

IP45 protection degree.

Stylish bright finishing of the front cover to meet any modern interior design requirement.

Aerodynamic-shaped inlet and front deflectors to reduce turbulences so to optimize the efficiency and the acoustic comfort.

Rigid optimised spigot support preventing distortion with strengthened guard and design to maximise airflow.

Back-draught shutter (accessory) to prevent air flowing back into the room when the fan is off.

Totally recyclable plastic components, environmentally friendly.

Double insulated: no earth connection is required.

Tested to the latest standards: units are tested in the TÜV Rheinland recognised laboratory at Aerauliqa, meaning accurate, up to date information on electrical safety, performance and noise level that can be relied upon.
Designed and manufactured in accordance with EN60335-2-80 (Low Voltage Directive) and the EMC Directive (Electromagnetic Compatibility).

MODELS

Quasar N

Equipped with high quality sleeve bearing motor.
Single speed operation.
Low power consumption (8W).

Quasar 2VBB

Equipped with ball bearing motor to assure a longer fan life (30.000h): ideal for cold climates.
Two speed operation.
Top performance (105 m³/h).
Low power consumption (from 5W).

Article code

Model Quasar	N	2S BB
Code	001183	001201

Installation



Dimensions (mm) and Weight

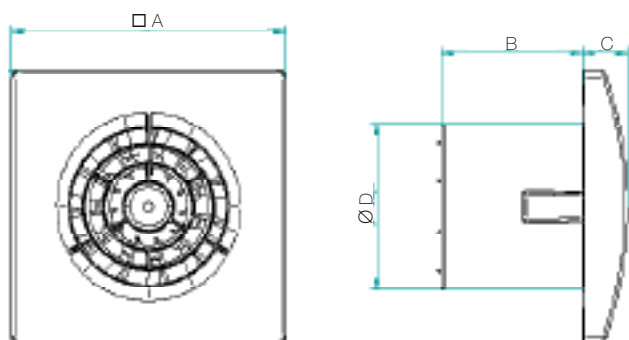

Model	Quasar
A	164
B	84
C	27
Ø D	99,4
Weight Kg	0,5

Performance curve

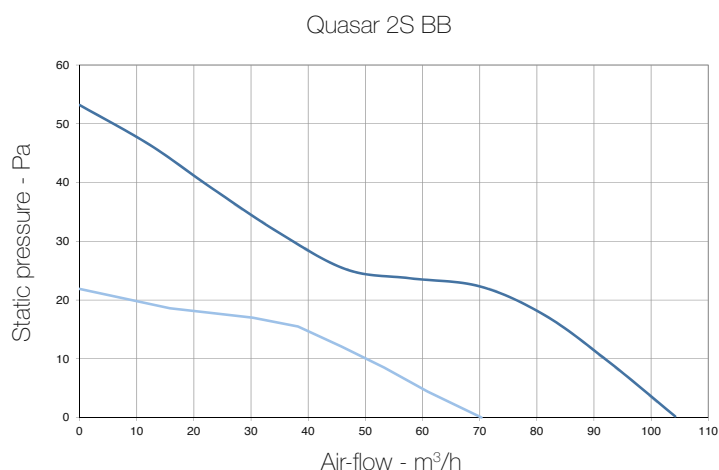
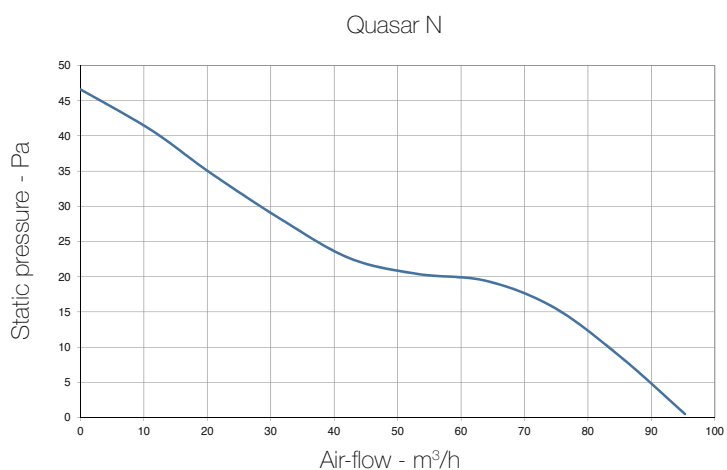

Performances

Model	Quasar N	Quasar 2S BB
Air-flow m³/h	95	105/70
Static pressure Pa max	47	53/22
Power consumption W max	8	8/5
Sound pressure dB(A) ⁽¹⁾ @3m	25	26/22
Ambient temperature °C max	50	50
Marking	CE	CE

- 220-240 V ~ 50-60Hz
- Air performance measured according to ISO 5801 a 230V 50Hz, air density 1,2 Kg/m³
- data measured in the TÜV Rheinland recognised laboratory in Aerauliga
- (1) sound pressure level @ 3m in free field