

DATA SHEET

TDA8565Q

**4 x 12 W single-ended car radio
power amplifier with diagnostic
interface**

Preliminary specification
File under Integrated Circuits, IC01

November 1994

Philips Semiconductors



PHILIPS

■ 7110826 0082861 568 ■

4 x 12 W single-ended car radio power amplifier with diagnostic interface

TDA8565Q

FEATURES

- Requires very few external components
- High output power
- Fixed gain
- Diagnostic facility (distortion, short-circuit and temperature detection)
- Good ripple rejection
- Mode select switch (operating, mute and standby)
- Load dump protection
- AC and DC short-circuit safe to ground and to V_P
- Low power dissipation in any short-circuit condition
- Thermally protected
- Reverse polarity safe
- Electrostatic discharge protection
- No switch-on/switch-off plop
- Flexible leads
- Low thermal resistance
- Identical inputs.

GENERAL DESCRIPTION

The TDA8565Q is an integrated class-B output amplifier in a 17-lead DIL-bent-to-SIL power package. It contains 4 x 12 W single-ended amplifiers.

APPLICATIONS

- The device is primarily developed for car radio applications.

QUICK REFERENCE DATA

SYMBOL	PARAMETER	CONDITIONS	MIN.	TYP.	MAX.	UNIT
V_P	operating supply voltage		6.0	14.4	18.0	V
I_{ORM}	repetitive peak output current		–	–	4	A
$I_{q(tot)}$	total quiescent current		–	88	–	mA
I_{sb}	standby current		–	0.1	100	μ A
$ Z_i $	input impedance		50	–	–	k Ω
P_o	output power	$R_L = 4 \Omega$; THD = 10%	–	6.4	–	W
		$R_L = 2 \Omega$; THD = 10%	–	12	–	W
SVRR	supply voltage ripple rejection		–	41	–	dB
V_{no}	noise output voltage	$R_s = 0 \Omega$	–	200	–	μ V

ORDERING INFORMATION

TYPE NUMBER	PACKAGE		
	NAME	DESCRIPTION	VERSION
TDA8565Q	DBS17P	plastic DIL-bent-to-SIL power package; 17 leads (lead length 12 mm)	SOT243-1

4 x 12 W single-ended car radio power amplifier with diagnostic interface

TDA8565Q

BLOCK DIAGRAM

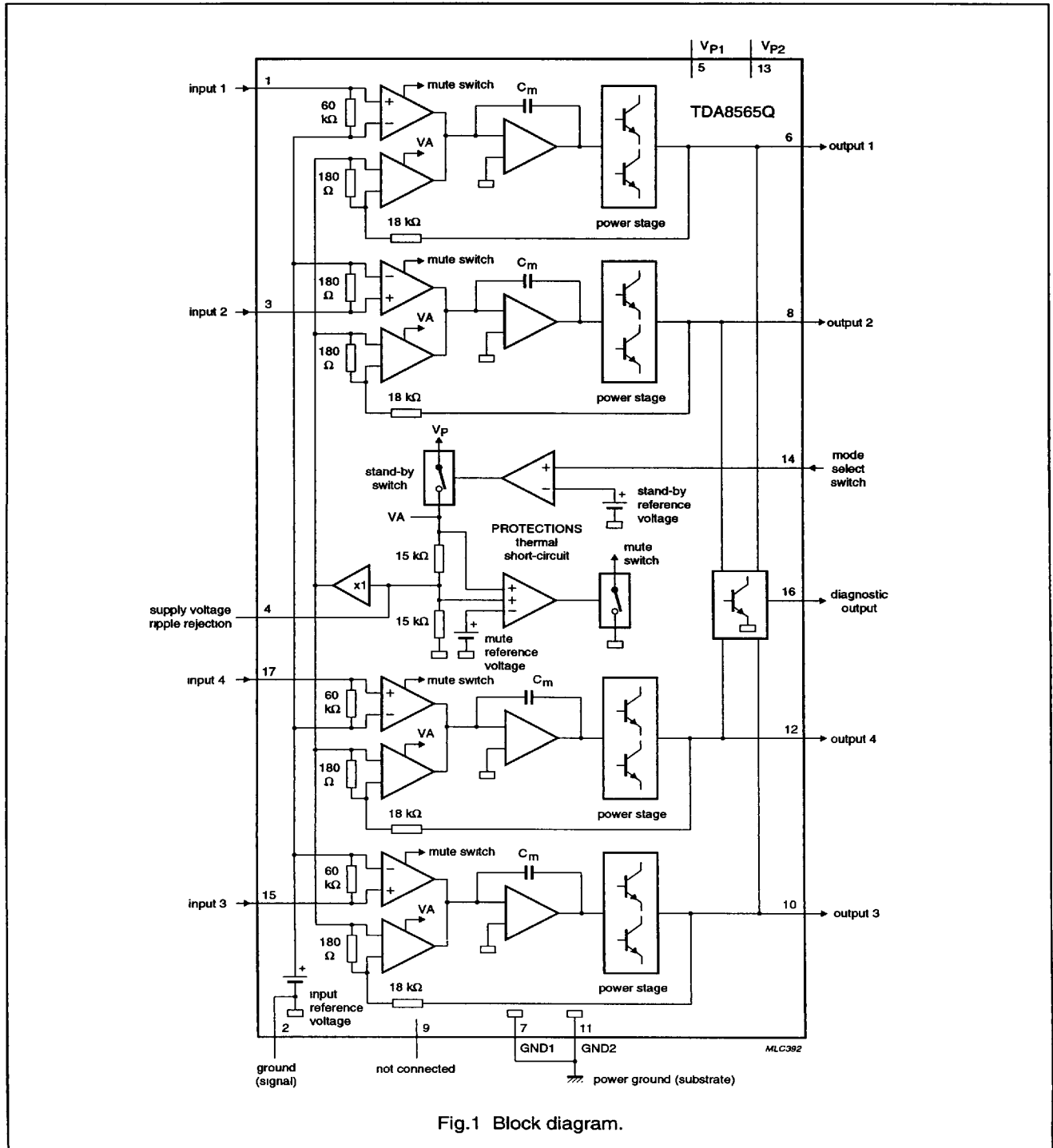

Fig.1 Block diagram.

4 x 12 W single-ended car radio power amplifier with diagnostic interface

TDA8565Q

PINNING

SYMBOL	PIN	DESCRIPTION
IN1	1	input 1
SGND	2	signal ground
IN2	3	input 2
SVRR	4	supply voltage ripple rejection
V _{P1}	5	supply voltage 1
OUT1	6	output 1
GND1	7	power ground 1
OUT2	8	output 2
n.c.	9	not connected
OUT3	10	output 3
GND2	11	power ground 2
OUT4	12	output 4
V _{P2}	13	supply voltage 2
MODE	14	mode select switch input
IN3	15	input 3
V _{DIAG}	16	diagnostic output
IN4	17	input 4

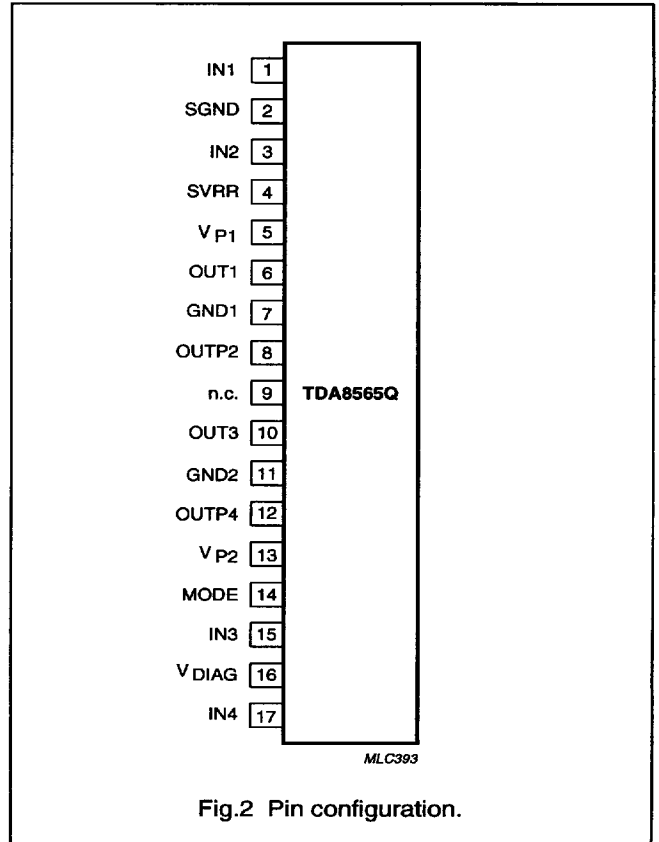

Fig.2 Pin configuration.

FUNCTIONAL DESCRIPTION

The TDA8565Q contains four identical amplifiers which can be used for single-ended applications. The gain of each amplifier is fixed at 40 dB. Special features of the device are as follows.

Mode select switch (pin 14)

- Low standby current (<100 μA)
- Low switching current (low cost supply switch)
- Mute facility.

To avoid switch-on plops, it is advised to keep the amplifier in the mute mode during ≥100 ms (charging of the input capacitors at pins 1, 3, 15 and 17).

This can be achieved by:

- Microcontroller control
- External timing circuitry (see Fig.3).

The circuit in Fig.3 slowly ramps up the voltage at the mode select switch pin when switching on and results in fast muting when switching off.

In the event of fast switching at mode select pin it is advised to increase the 1/2V_P decoupling capacitor (pin 4) to 150 μF to avoid switch plops.

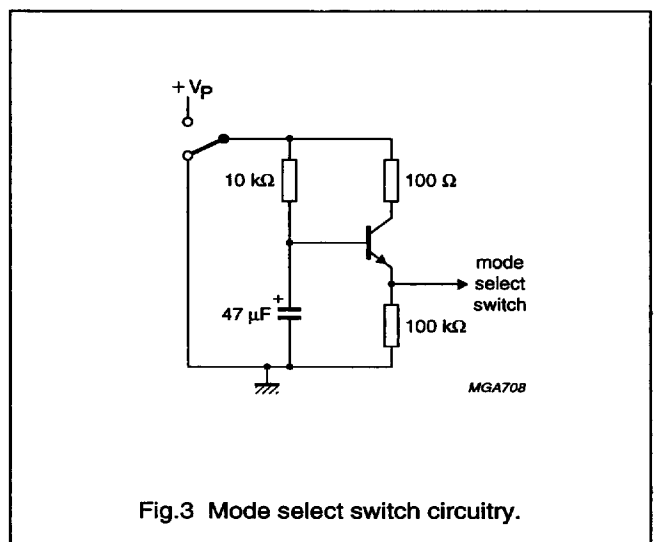

Fig.3 Mode select switch circuitry.

4 x 12 W single-ended car radio power amplifier with diagnostic interface

TDA8565Q

Diagnostic output (pin 16)

DYNAMIC DISTORTION DETECTOR (DDD)

At the onset of clipping of one or more output stages, the dynamic distortion detector becomes active and pin 16 goes LOW. This information can be used to drive a sound processor or DC volume control to attenuate the input signal and thus limit the distortion. The output level of pin 16 is independent of the number of channels that are clipping (see Fig.4).

SHORT-CIRCUIT PROTECTION

When a short-circuit occurs at one or more outputs to ground or to the supply voltage, the output stages are switched off until the short-circuit is removed and the device is switched on again, with a delay of approximately 20 ms after removal of the short-circuit. During this short-circuit condition, pin 16 is continuously LOW.

When a short-circuit across the load of one or more channels occurs the output stages are switched off during approximately 20 ms. After that time it is checked during approximately 50 μ s to see whether the short-circuit is still present. Due to this duty cycle of 50 μ s/20 ms the average current consumption during this short-circuit condition is very low (approximately 40 mA).

During this short-circuit condition, pin 16 is LOW for 20 ms and HIGH for 50 μ s (see Fig.5).

The power dissipation in any short-circuit condition is very low.

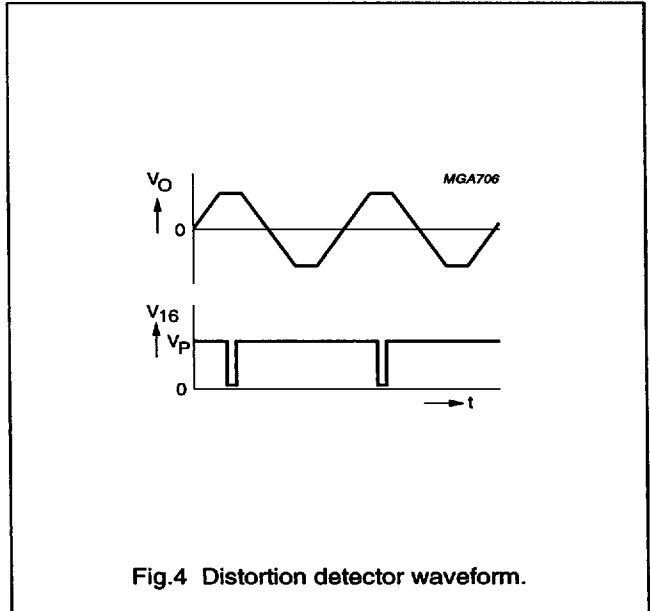

Fig.4 Distortion detector waveform.

TEMPERATURE DETECTION

When the virtual junction temperature T_{vj} reaches 150 $^{\circ}$ C, pin 16 will be active LOW.

OPEN COLLECTOR OUTPUT

Pin 16 is an open-collector output, which allows pin 16 of more devices being tied together.

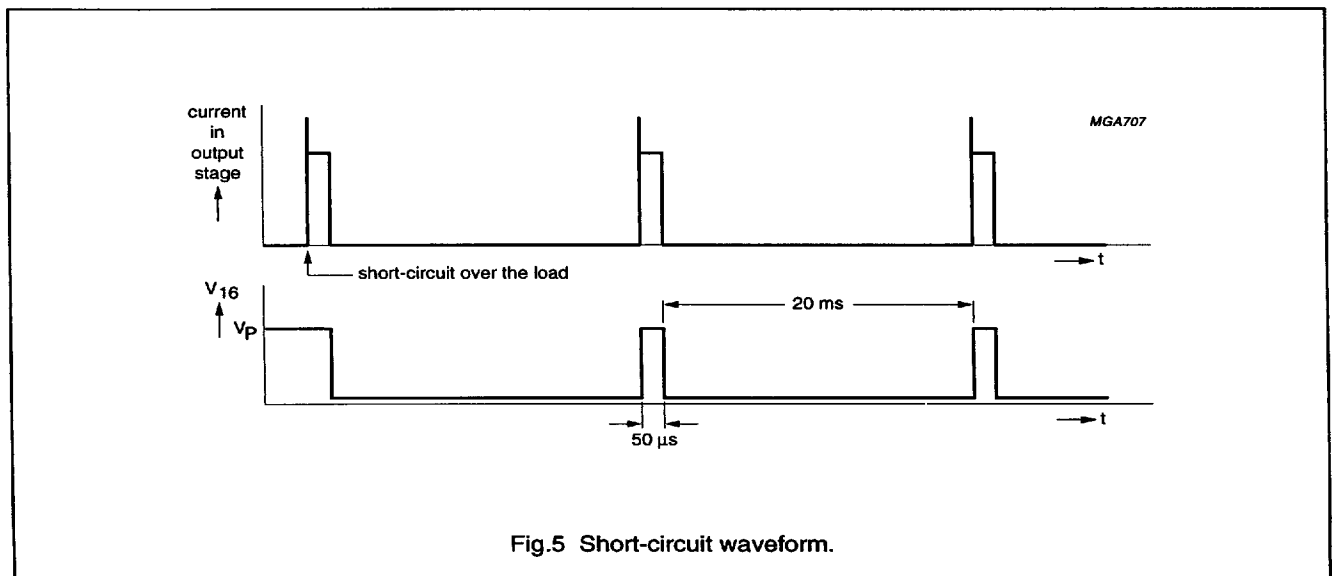

Fig.5 Short-circuit waveform.

4 x 12 W single-ended car radio power amplifier with diagnostic interface

TDA8565Q

LIMITING VALUES

In accordance with the Absolute Maximum Rating System (IEC 134).

SYMBOL	PARAMETER	CONDITIONS	MIN.	MAX.	UNIT
V _P	supply voltage			18	V
	operating		-	30	V
	non-operating		-	45	V
	load dump protection	during 50 ms; t _r ≥ 2.5 ms	-	45	V
V _{psc}	AC and DC short-circuit safe voltage		-	18	V
V _{pr}	reverse polarity		-	6	V
I _{OSM}	non-repetitive peak output current		-	6	A
I _{ORM}	repetitive peak output current		-	4	A
P _{tot}	total power dissipation		-	60	W
T _{stg}	storage temperature		-55	+150	°C
T _{amb}	operating ambient temperature		-40	+85	°C
T _{vj}	virtual junction temperature		-	150	°C

THERMAL CHARACTERISTICS

SYMBOL	PARAMETER	VALUE	UNIT
R _{th j-a}	thermal resistance from junction to ambient in free air	40	K/W
R _{th j-c}	thermal resistance from junction to case (see Fig.6)	1.3	K/W

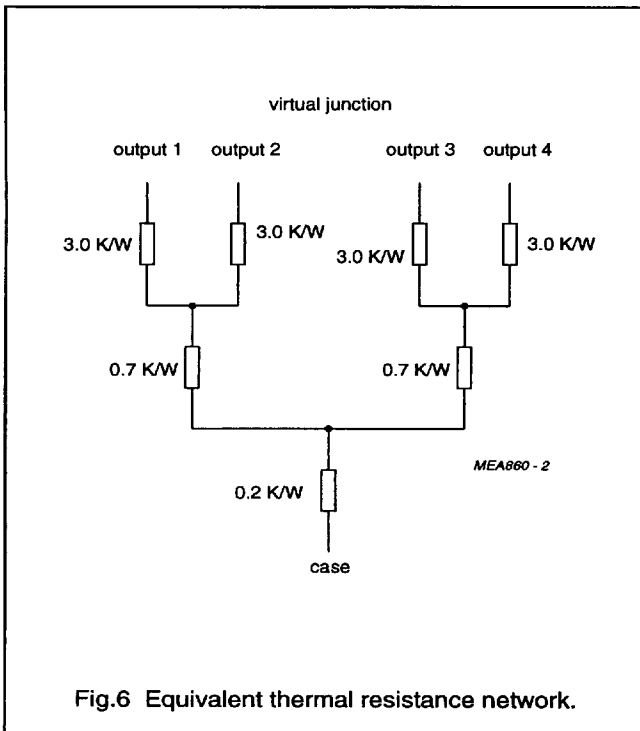

4 x 12 W single-ended car radio power amplifier with diagnostic interface

TDA8565Q

DC CHARACTERISTICS

$V_P = 14.4 \text{ V}$; $T_{amb} = 25 \text{ }^\circ\text{C}$; measured in Fig.14; unless otherwise specified.

SYMBOL	PARAMETER	CONDITIONS	MIN.	TYP.	MAX.	UNIT
Supply						
V_P	supply voltage	note 1	6.0	14.4	18.0	V
I_q	quiescent current		-	88	160	mA
V_O	DC output voltage	note 2	-	6.95	-	V
Mute select switch						
V_{14}	switch-on voltage level		8.5	-	-	V
MUTE CONDITION						
V_{mute}	mute voltage		3.3	-	6.4	V
V_O	output signal in mute position	$V_{I(max)} = 1 \text{ V}$; $f = 1 \text{ kHz}$	-	-	2	mV
STANDBY CONDITION						
V_{sb}	DC voltage in standby condition		0	-	2	V
I_{sb}	DC current in standby condition		-	-	100	μA
V_{sw}	switch-on current		-	12	40	μA
Diagnostic output (pin 16)						
V_{DIAG}	diagnostic output voltage	any short-circuit or clipping	-	-	0.6	V

Notes

1. The circuit is DC adjusted at $V_P = 6$ to 18 V and AC operating at $V_P = 8.5$ to 18 V .
2. At $18 \text{ V} < V_P < 30 \text{ V}$ the DC output voltage $\leq \frac{1}{2}V_P$.

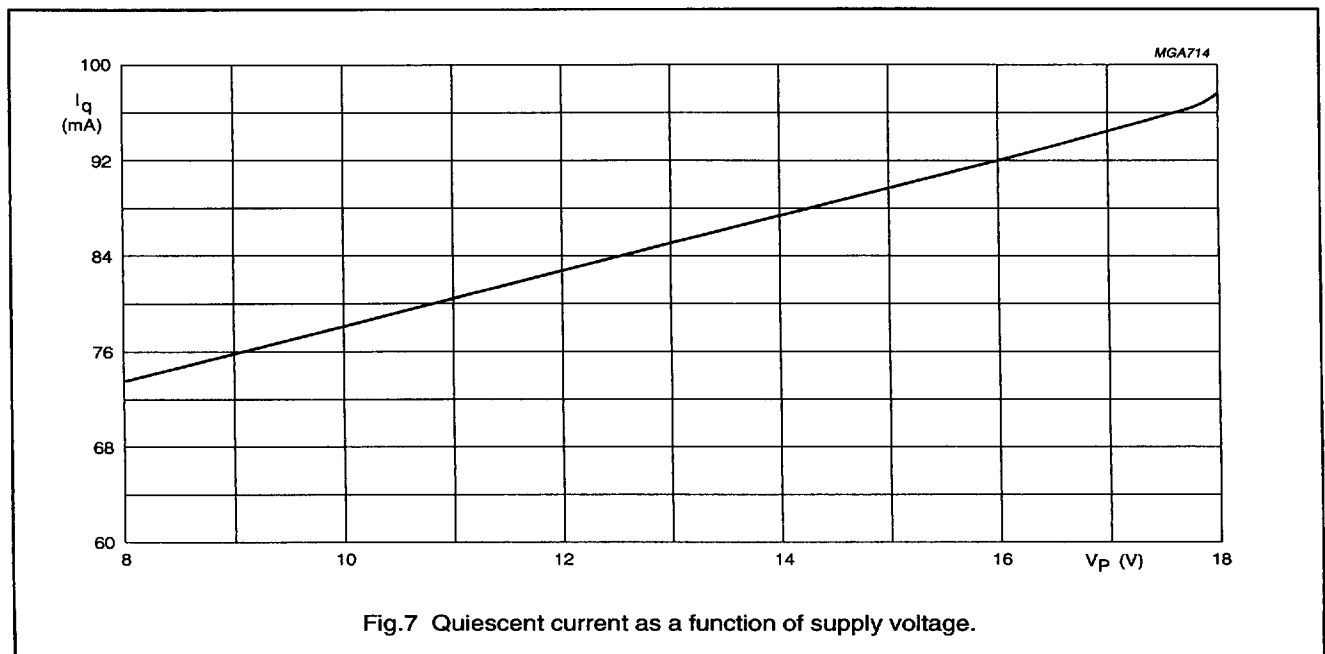

4 x 12 W single-ended car radio power amplifier with diagnostic interface

TDA8565Q

AC CHARACTERISTICS

$V_P = 14.4$ V; $R_L = 4$ Ω ; $f = 1$ kHz; $T_{amb} = ^\circ\text{C}$; measured in Fig.14; unless otherwise specified.

SYMBOL	PARAMETER	CONDITIONS	MIN.	TYP.	MAX.	UNIT
P_o	output power	THD = 0.5%; note 1	4	5	–	W
		THD = 10%; note 1	5.5	6.4	–	W
P_o	output power	$R_L = 2$ Ω ; THD = 0.5%; note 1	–	8.5	–	W
		$R_L = 2$ Ω ; THD = 10%; note 1	–	12	–	W
THD	total harmonic distortion	$P_o = 1$ W	–	0.15	–	%
f_{lr}	low frequency roll-off	at –3 dB; note 2	–	45	–	Hz
f_{hr}	high frequency roll-off	at –1 dB	20	–	–	kHz
G_v	closed loop voltage gain		39	40	41	dB
SVRR	supply voltage ripple rejection on mute standby	note 3	38	41	–	dB
		note 3	42	48	–	dB
		$f = 100$ Hz to 10 kHz; note 3	80	90	–	dB
$ Z_i $	input impedance		50	60	75	k Ω
V_{no}	noise output voltage on on mute	$R_s = 0$ Ω ; note 4	–	200	300	μV
		$R_s = 10$ Ω ; note 4	–	250	–	μV
		notes 4 and 5	–	175	–	μV
α_{cs}	channel separation	$R_s = 10$ Ω	40	52	–	dB
$ \Delta G_v $	channel unbalance		–	–	1	dB
Dynamic distortion detector						
THD	total harmonic distortion	$V_{16} \leq 0.6$ V; no short-circuit	–	10	–	%

Notes

- Output power is measured directly at the output pins of the IC.
- Frequency response externally fixed.
- Ripple rejection measured at the output with a source impedance of 0 Ω , maximum ripple amplitude of 2 V (p-p).
- Noise voltage measured in a bandwidth of 20 Hz to 20 kHz.
- Noise output voltage independent of R_s ($V_i = 0$ V).

4 x 12 W single-ended car radio power amplifier with diagnostic interface

TDA8565Q

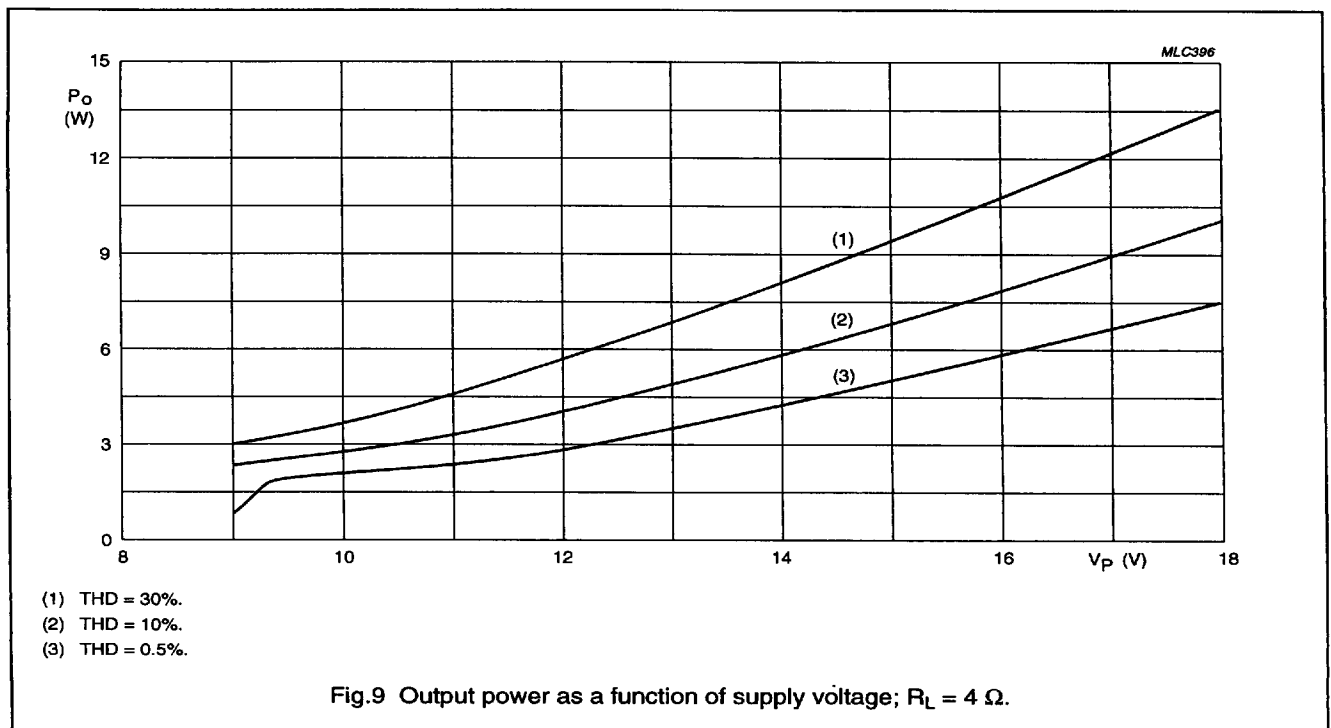
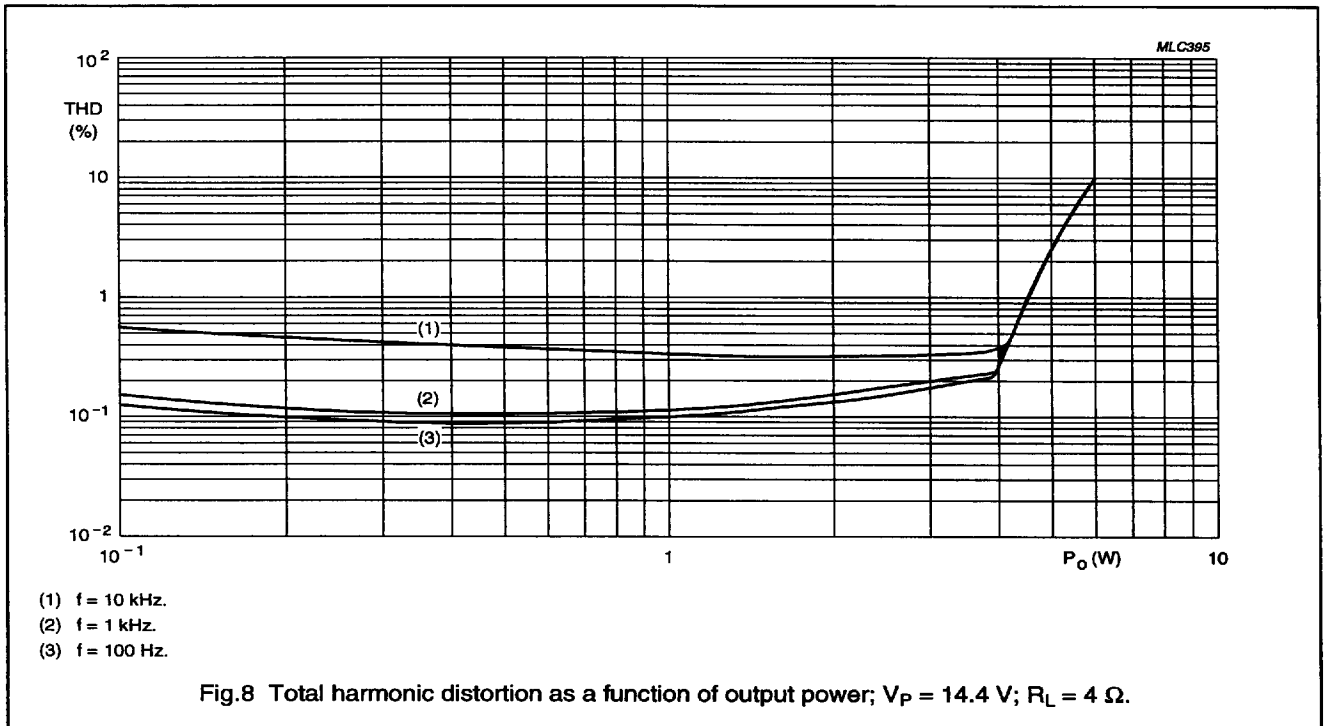

4 x 12 W single-ended car radio power amplifier with diagnostic interface

TDA8565Q

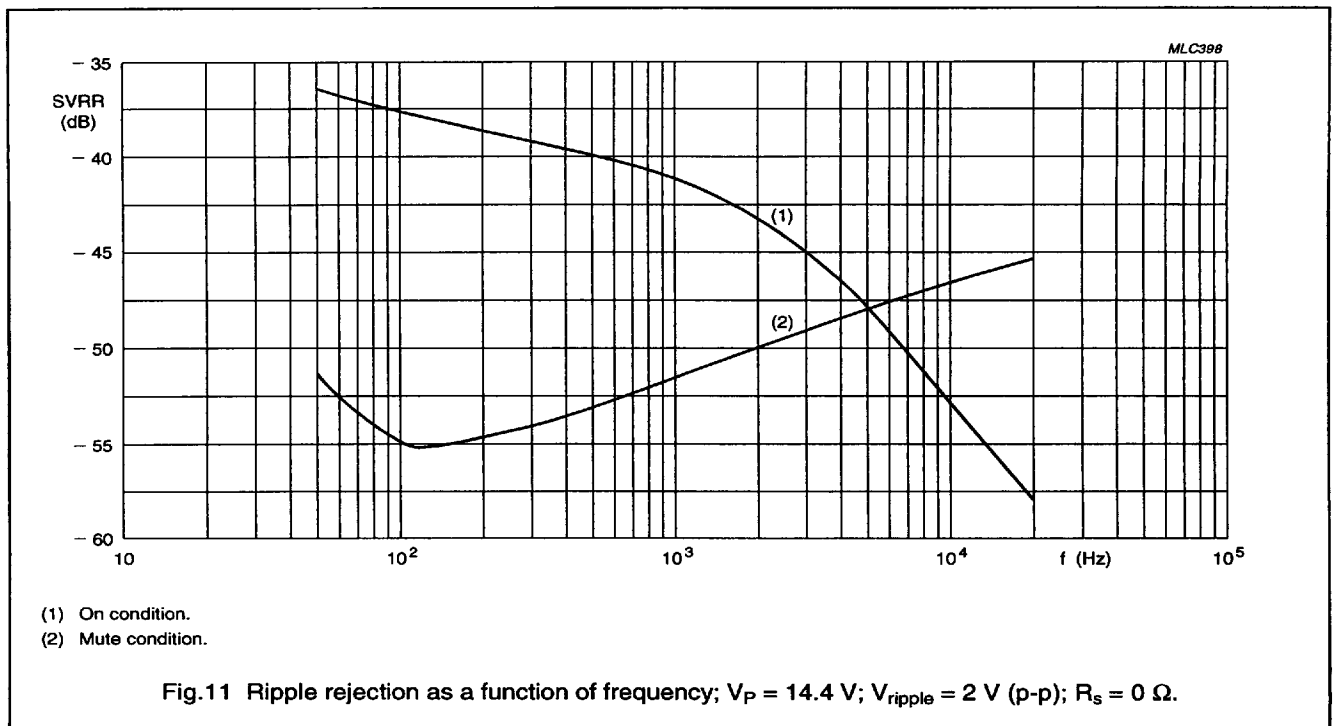
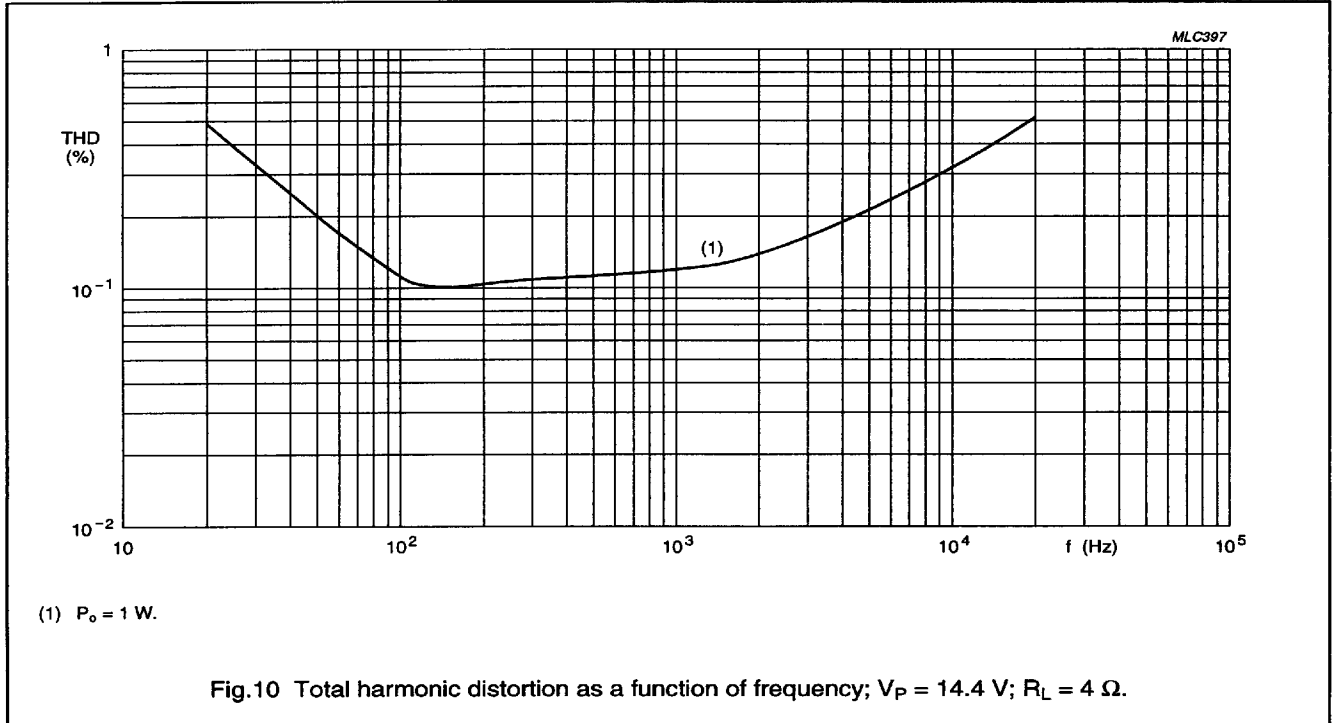

4 x 12 W single-ended car radio power amplifier with diagnostic interface

TDA8565Q

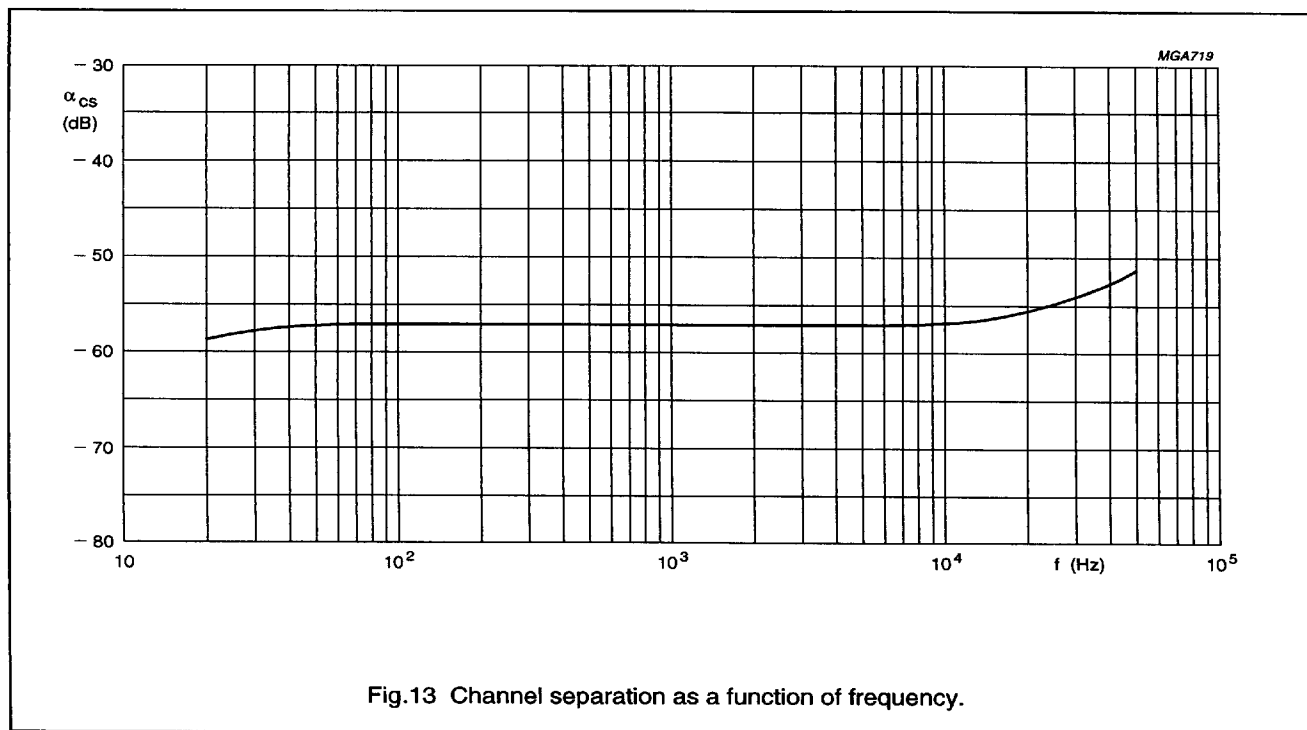
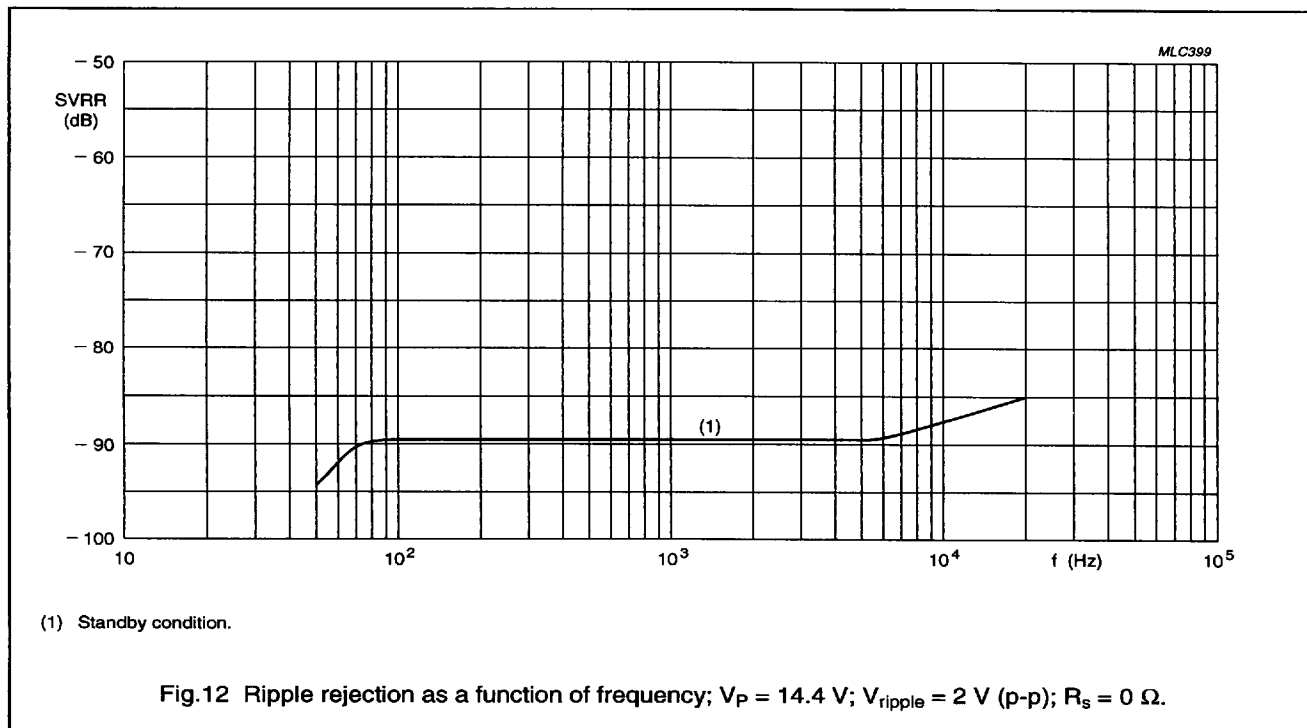

4 x 12 W single-ended car radio power amplifier with diagnostic interface

TDA8565Q

TEST/APPLICATION INFORMATION

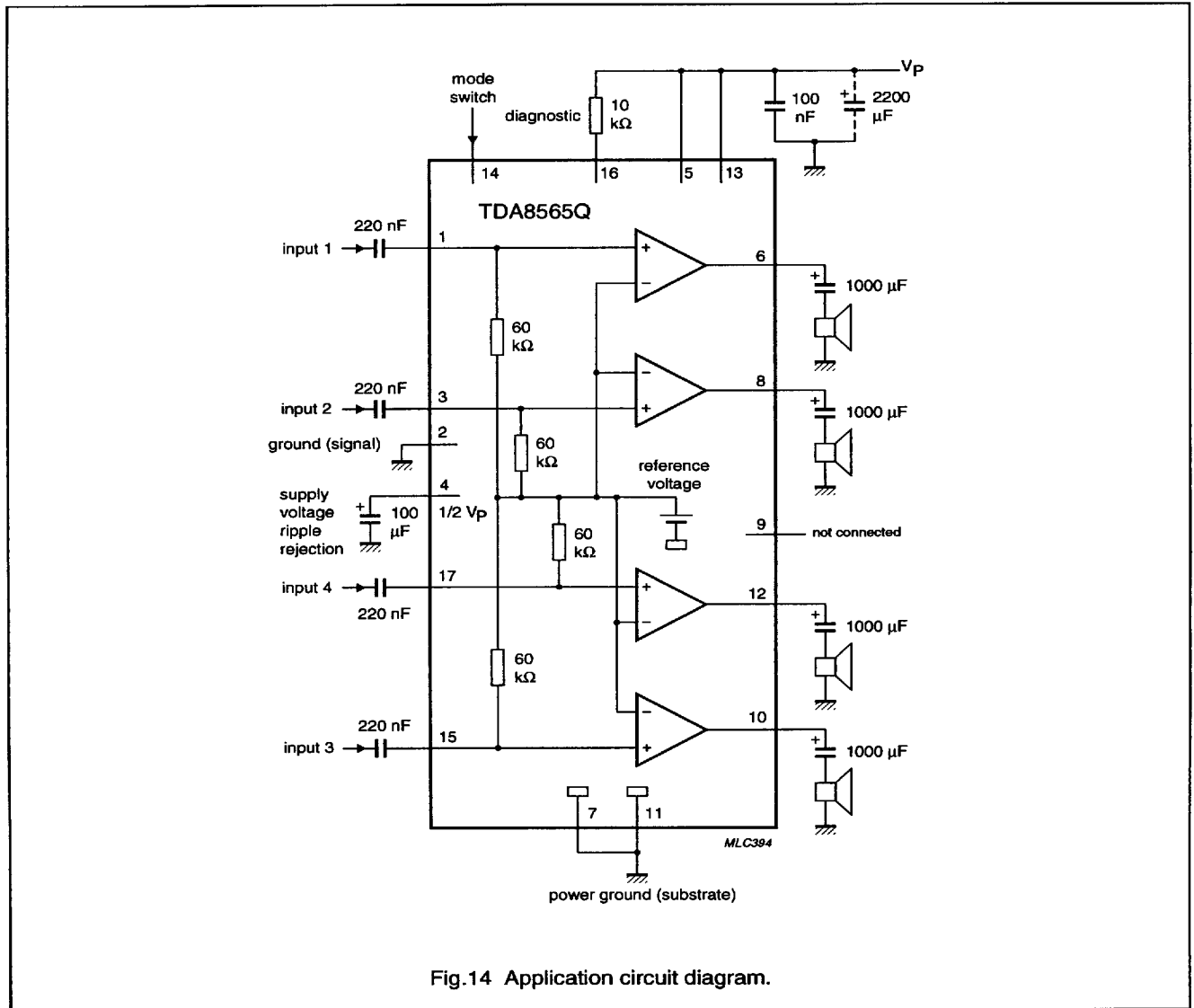
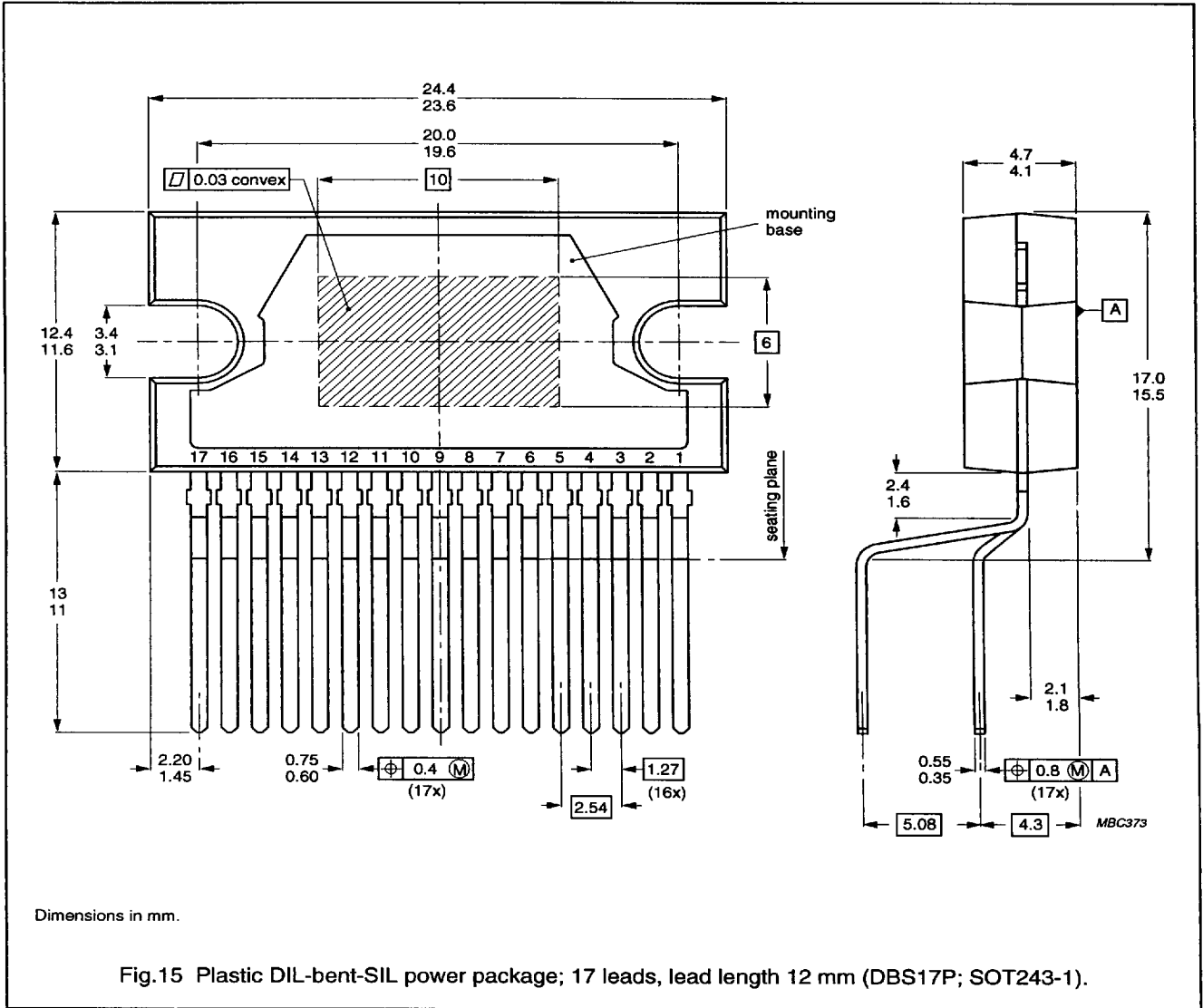

Fig.14 Application circuit diagram.

4 x 12 W single-ended car radio power amplifier with diagnostic interface

TDA8565Q

PACKAGE OUTLINE



4 x 12 W single-ended car radio power amplifier with diagnostic interface

TDA8565Q

SOLDERING

Plastic dual in-line packages

BY DIP OR WAVE

The maximum permissible temperature of the solder is 260 °C; this temperature must not be in contact with the joint for more than 5 s. The total contact time of successive solder waves must not exceed 5 s.

The device may be mounted up to the seating plane, but the temperature of the plastic body must not exceed the

specified storage maximum. If the printed-circuit board has been pre-heated, forced cooling may be necessary immediately after soldering to keep the temperature within the permissible limit.

REPAIRING SOLDERED JOINTS

Apply the soldering iron below the seating plane (or not more than 2 mm above it). If its temperature is below 300 °C, it must not be in contact for more than 10 s; if between 300 and 400 °C, for not more than 5 s.

DEFINITIONS

Data sheet status	
Objective specification	This data sheet contains target or goal specifications for product development.
Preliminary specification	This data sheet contains preliminary data; supplementary data may be published later.
Product specification	This data sheet contains final product specifications.
Limiting values	
Limiting values given are in accordance with the Absolute Maximum Rating System (IEC 134). Stress above one or more of the limiting values may cause permanent damage to the device. These are stress ratings only and operation of the device at these or at any other conditions above those given in the Characteristics sections of the specification is not implied. Exposure to limiting values for extended periods may affect device reliability.	
Application information	
Where application information is given, it is advisory and does not form part of the specification.	

LIFE SUPPORT APPLICATIONS

These products are not designed for use in life support appliances, devices, or systems where malfunction of these products can reasonably be expected to result in personal injury. Philips customers using or selling these products for use in such applications do so at their own risk and agree to fully indemnify Philips for any damages resulting from such improper use or sale.