

1.3 DULCOTEST® Conductivity Sensors



Conductivity Sensor LMP 1-HT

Sensor for the measurement of the electrolytic conductivity for clear and also chemically contaminated water. For high temperatures, with integrated temperature measurement and DIN 4-pin plug. For operation with the controllers Compact DCCa, DMTa, D1Ca

Your benefits

- Measured variable: electrolytic conductivity above 0.1 mS/cm
- Cost-effective sensor for clear, chemically contaminated water
- Resistant to the ingredients in the water of the target applications
- Integrated Pt 100 for temperature compensation replaces separate temperature sensor and the corresponding sensor fitting
- Temperature resistance up to 100 °C

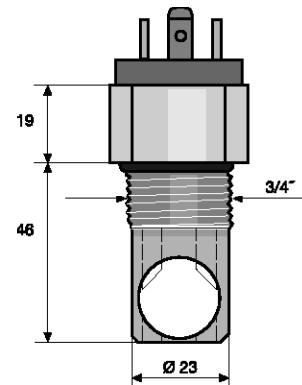

pk_6_052

Measuring range	0.1...20 mS/cm
Cell constant k	1.00 cm ⁻¹ ±5%
Temperature measurement	Pt 100
Medium temperature	0 ... 120 °C (at 1 bar)
Max. pressure	16.0 bar, (at 100 °C)
Sensors	Graphite
Shaft material	PVDF
Thread	3/4"
Length when fitted	46 mm
Installation	Inline: direct installation into the pipework, bypass: with or without return of the sample water into the process line
Electrical connection	DIN 4-pin angle plug
Enclosure rating	IP 65
Typical applications	General applications at higher temperatures process water, process water from electroplating, media separation, with CIP (cleaning in place)
Resistance to	Ingredients in the water of the target application, taking into account the compatibility of the material
Measuring and control equipment	Compact DCCa, DMTa, D1Ca, AEGIS II
Measuring principle, technology	Conductive, 2 electrodes. Integrated temperature measurement

	Order no.
LMP 1-HT	1020524

Please observe the general notes on p. → 1-85 (Overview Table for Conductivity Sensors)