

5V to 12V Supply Voltage, 8-PIN, Synchronous Buck PWM Controller

Features

- **Operating with Single 5~12V Supply Voltage or two Supply Voltages**
- **Drive Dual Low Cost N-Channel MOSFETs**
 - Adaptive Shoot-Through Protection
- **Built-in Feedback Compensation**
 - Voltage-Mode PWM Control
 - 0~100% Duty Ratio
 - Fast Transient Response
- **±2% 0.8V Reference**
 - Over Line, Load Regulation, and Operating Temperature
- **Programmable Over-Current Protection**
 - Using $R_{DS(ON)}$ of Low-Side MOSFET
- **Hiccup-Mode Under-Voltage Protection**
- **118% Over-Voltage Protection**
- **Adjustable Output Voltage**
- **Small Converter Size**
 - 300kHz Constant Switching Frequency
 - Small SOP-8 Package
- **Built-In Digital Soft-Start**
- **Shutdown Control using an External MOSFET**
- **Lead Free and Green Devices Available (RoHS Compliant)**

Applications

- **Motherboard**
- **Graphics Card**
- **High Current, up to 20A, DC-DC Converters**

General Description

The APW7120A is a fixed 300kHz frequency, voltage mode, and synchronous PWM controller. The device drives two low cost N-channel MOSFETs and is designed to work with single 5~12V or two supply voltage(s), providing excellent regulation for load transients.

The APW7120A integrates controls, monitoring and protection functions into a single 8-pin package to provide a low cost and perfect power solution.

A power-on-reset (POR) circuit monitors the VCC supply voltage to prevent wrong logic controls. An internal 0.8V reference provides low output voltage down to 0.8V for further applications. An built-in digital soft-start with fixed soft-start interval prevents the output voltage from overshoot as well as limiting the input current. The controller's over-current protection monitors the output current by using the voltage drop across the low-side MOSFET's $R_{DS(ON)}$, eliminating the need of a current sensing resistor. Additional under voltage and over voltage protections monitor the voltage on FB pin for short-circuit and over-voltage protections. The over-current protection cycles the soft-start function until 4 over-current events are counted.

Pulling and holding the voltage on OCSET pin below 0.15V with an open drain device shuts down the controller.

Pin Configuration

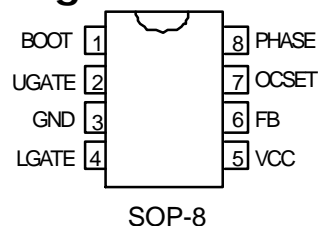

ANPEC reserves the right to make changes to improve reliability or manufacturability without notice, and advise customers to obtain the latest version of relevant information to verify before placing orders.

Ordering and Marking Information

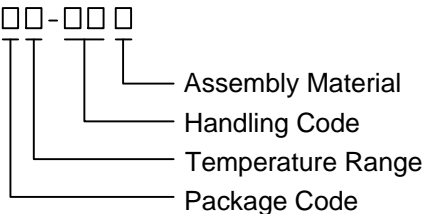
<p>APW7120A □□-□□□</p>  <p> Assembly Material Handling Code Temperature Range Package Code </p>	<p>Package Code K : SOP-8</p> <p>Operating Ambient Temperature Range E : -20 to 70 °C</p> <p>Handling Code TR : Tape & Reel</p> <p>Assembly Material L : Lead Free Device G : Halogen and Lead Free Device</p>
<p>APW7120A K : APW7120A XXXXX</p>	<p>XXXXX - Date Code</p>

Note: ANPEC lead-free products contain molding compounds/die attach materials and 100% matte tin plate termination finish; which are fully compliant with RoHS. ANPEC lead-free products meet or exceed the lead-free requirements of IPC/JEDEC J-STD-020C for MSL classification at lead-free peak reflow temperature. ANPEC defines "Green" to mean lead-free (RoHS compliant) and halogen free (Br or Cl does not exceed 900ppm by weight in homogeneous material and total of Br and Cl does not exceed 1500ppm by weight).

Absolute Maximum Ratings (Note 1)

Symbol	Parameter	Rating	Unit
V_{CC}	VCC Supply Voltage (VCC to GND)	-0.3 ~ 16	V
V_{BOOT}	BOOT Voltage (BOOT to PHASE)	-0.3 ~ 16	V
	UGATE Voltage (UGATE to PHASE)		V
	<400ns pulse width	-5 ~ $V_{BOOT}+0.3$	
	>400ns pulse width	-0.3 ~ $V_{BOOT}+0.3$	
	LGATE Voltage (LGATE to GND)		V
	<400ns pulse width	-5 ~ $V_{CC}+0.3$	
	>400ns pulse width	-0.3 ~ $V_{CC}+0.3$	
	PHASE Voltage (PHASE to GND)		V
	<400ns pulse width	-10 ~ 30	
	>400ns pulse width	-3 ~ 16	
V_{IO}	Input Voltage (OCSET, FB to GND)	-0.3 ~ 7	V
	Maximum Junction Temperature	150	°C
T_{STG}	Storage Temperature	-65 ~ 150	°C
T_{SDR}	Maximum Lead Soldering Temperature, 10 Seconds	260	°C

Note 1: Absolute Maximum Ratings are those values beyond which the life of a device may be impaired. Exposure to absolute maximum rating conditions for extended periods may affect device reliability.

Thermal Characteristics

Symbol	Parameter	Typical Value	Unit
θ_{JA}	Junction-to-Ambient Resistance in Free Air ^(Note 2)	160	°C/W

Note 2: θ_{JA} is measured with the component mounted on a high effective thermal conductivity test board in free air.

Recommended Operating Conditions (Note 3)

Symbol	Parameter	Range	Unit
V_{CC}	VCC Supply Voltage	4.5 ~ 13.2	V
V_{OUT}	Converter Output Voltage	0.8 ~ 80% V_{IN}	V
V_{IN}	Converter Input Voltage	2.2 ~ 13.2	V
I_{OUT}	Converter Output Current	0 ~ 20	A
T_A	Ambient Temperature	-20 ~ 70	°C
T_J	Junction Temperature	-20 ~ 125	°C

Note 3: Please refer to the typical application circuit.

Electrical Characteristics

Unless otherwise specified, these specifications apply over $V_{CC} = 12V$, $V_{BOOT} = 12V$ and $T_A = -20 \sim 70^\circ C$.

Typical values are at $T_A = 25^\circ C$.

Symbol	Parameter	Test Conditions	APW7120A			Unit
			Min.	Typ.	Max.	
SUPPLY CURRENT						
I_{VCC}	VCC Nominal Supply Current	UGATE and LGATE Open	-	2.1	6	mA
	VCC Shutdown Supply Current		-	1.5	4	mA
POWER-ON-RESET						
	Rising VCC Threshold		3.8	4.1	4.4	V
	Hysteresis		0.1	0.45	0.6	V
OSCILLATOR						
F_{OSC}	Free Running Frequency		250	300	350	kHz
ΔV_{OSC}	Ramp Amplitude		-	1.5	-	V_{P-P}
REFERENCE VOLTAGE						
V_{REF}	Reference Voltage	Measured at FB Pin	-	0.8	-	V
	Accuracy	$T_A = -20 \sim 70^\circ C$	-2.0	-	+2.0	%
	Line Regulation	$V_{CC} = 12 \sim 5V$	-	0.05	0.5	%
ERROR AMPLIFIER						
	DC Gain		-	86	-	dB
F_{P1}	First Pole Frequency		-	0.4	-	Hz
F_Z	Zero Frequency		-	0.4	-	kHz
F_{P2}	Second Pole Frequency		-	430	-	kHz
	Average UGATE Duty Range		0	-	85	%
	FB Input Current		-	-	0.1	μA

Electrical Characteristics (Cont.)

Unless otherwise specified, these specifications apply over $V_{CC} = 12V$, $V_{BOOT} = 12V$ and $T_A = -20 \sim 70^\circ C$.

Typical values are at $T_A = 25^\circ C$.

Symbol	Parameter	Test Conditions	APW7120A			Unit
			Min.	Typ.	Max.	
PWM CONTROLLER GATE DRIVERS						
	UGATE Source	$V_{BOOT-PHASE} = 12V, V_{UGATE-PHASE} = 6V$	1.0	2.0	-	A
	UGATE Sink	$V_{BOOT-PHASE} = 12V, V_{UGATE-PHASE} = 1V$	-	3.5	7	Ω
	LGATE Source	$V_{CC} = 12V, V_{LGATE} = 6V$	1.0	1.9	-	A
	LGATE Sink	$V_{CC} = 12V, V_{LGATE} = 1V$	-	2.6	5	Ω
T_D	Dead-Time	Guaranteed by Design	-	40	100	ns
PROTECTIONS						
I_{OCSET}	OCSET Current Source	$V_{PHASE} = 0V$, Normal Operation	35	40	45	μA
	Over-Current Reference Voltage	$T_A = -20 \sim 70^\circ C$	0.37	0.4	0.43	V
U_{VFB}	FB Under-Voltage Threshold	V_{FB} Falling	62	67	72	%
	FB Under-Voltage Hysteresis		-	45	-	mV
	Over-Voltage Threshold	V_{FB} Rising	114	118	122	%
SOFT-START AND SHUTDOWN						
T_{SS}	Soft-Start Interval		2	3.8	5	ms
	OCSET Shutdown Threshold	Falling V_{OCSET}	0.1	0.15	0.3	V
	OCSET Shutdown Hysteresis		-	40	-	mV

Function Pin Description

BOOT (Pin 1)

This pin provides ground referenced bias voltage to the high-side MOSFET driver. A bootstrap circuit with a diode connected to 5~12V is used to create a voltage suitable to drive a logic-level N-channel MOSFET.

UGATE (Pin 2)

Connect this pin to the high-side N-channel MOSFET's gate. This pin provides gate drive for the high-side MOSFET.

GND (Pin 3)

The GND terminal provides return path for the IC's bias current and the low-side MOSFET driver's pull-low current. Connect the pin to the system ground via very low impedance layout on PCBs.

LGATE (Pin 4)

Connect this pin to the low-side N-channel MOSFET's gate. This pin provides gate drive for the low-side MOSFET.

VCC (Pin 5)

Connect this pin to a 5~12V supply voltage. This pin provides bias supply for the control circuitry and the low-side MOSFET driver. The voltage at this pin is monitored for the Power-On-Reset (POR) purpose.

FB (Pin 6)

This pin is the inverting input of the internal Gm amplifier. Connect this pin to the output (V_{OUT}) of the converter via an external resistor divider for closed-loop operation. The output voltage set by the resistor divider is determined using the following formula :

$$V_{OUT} = 0.8V \cdot \left(1 + \frac{R1}{R2}\right) \quad (V)$$

where R1 is the resistor connected from V_{OUT} to FB , and R2 is the resistor connected from FB to GND. The FB pin is also monitored for under and over-voltage events.

OCSET (Pin 7)

The OCSET is a dual-function input pin for over-current protection and shutdown control. Connect a resistor (R_{OCSET}) from this pin to the Drain of the low-side MOSFET. This resistor, an internal 40 μ A current source (I_{OCSET}), and the MOSFET's on-resistance (R_{DSON}) set the converter over-current trip level (I_{PEAK}) according to the following formula:

$$I_{PEAK} = \frac{40\mu A \cdot R_{OCSET} - 0.4V}{R_{DSON}} \quad (A)$$

Pulling and holding this pin below 0.15V with an open drain device, with very low parasitic capacitor, shuts down the IC with floating output and also resets the over-current counter. Releasing OCSET pin initiates a new soft-start and the converter works again.

PHASE (Pin 8)

The pin provides return path for the high-side MOSFET driver's pull-low current. Connect this pin to the high-side MOSFET's source.

Typical Operating Characteristics

Reference Voltage vs Junction Temperature

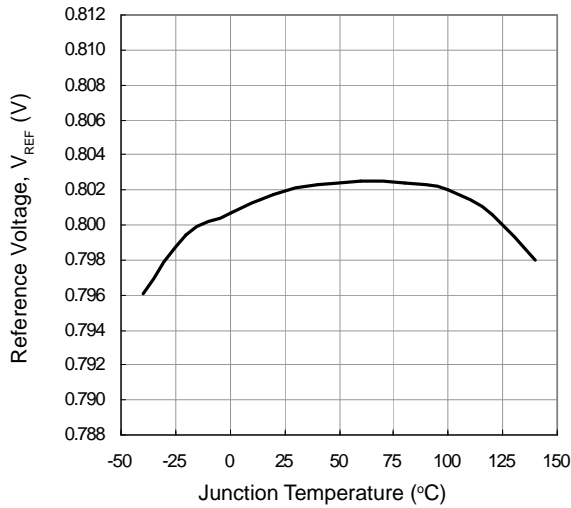

Switching Frequency vs Junction Temperature

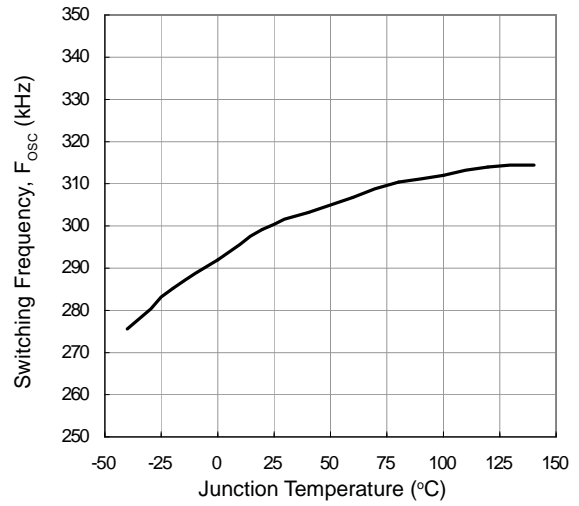

OCSET Current vs Junction Temperature

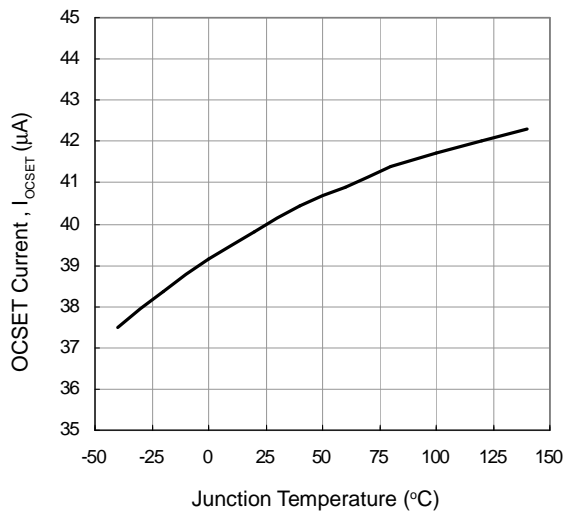

VCC POR Threshold Voltage vs Junction Temperature

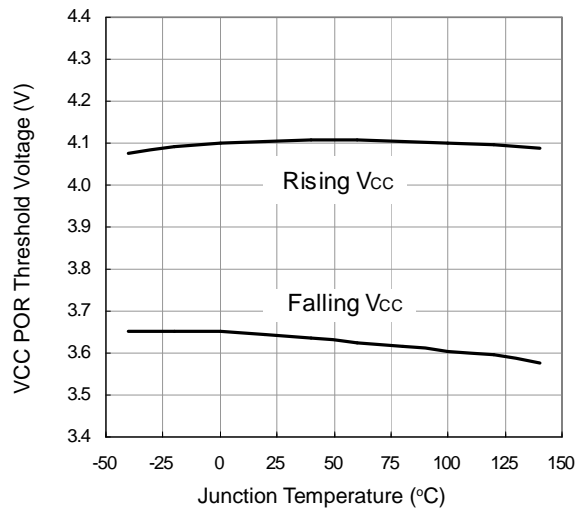

Typical Operating Characteristics (Cont.)

OCSET Shutdown Threshold Voltage vs Junction Temperature

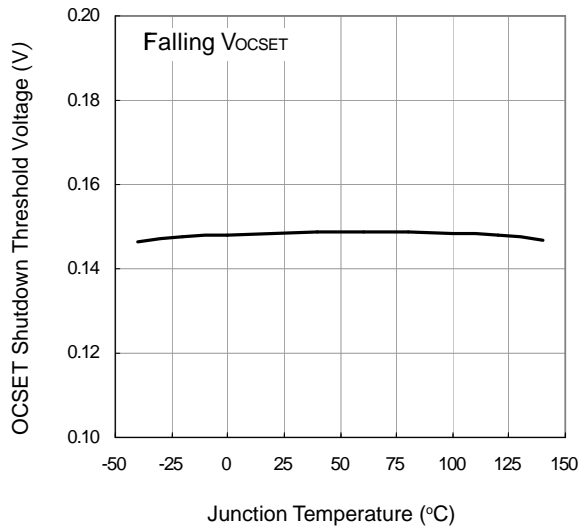

Operating Waveforms

(Refer to the typical application circuit, $V_{BAIS}=V_{IN}=+12V$ supplied by an ATX Power Supply)

1. Load Transient Response : $I_{OUT} = 0A \rightarrow 15A \rightarrow 0A$

- I_{OUT} slew rate = $\pm 7.5A/\mu s$

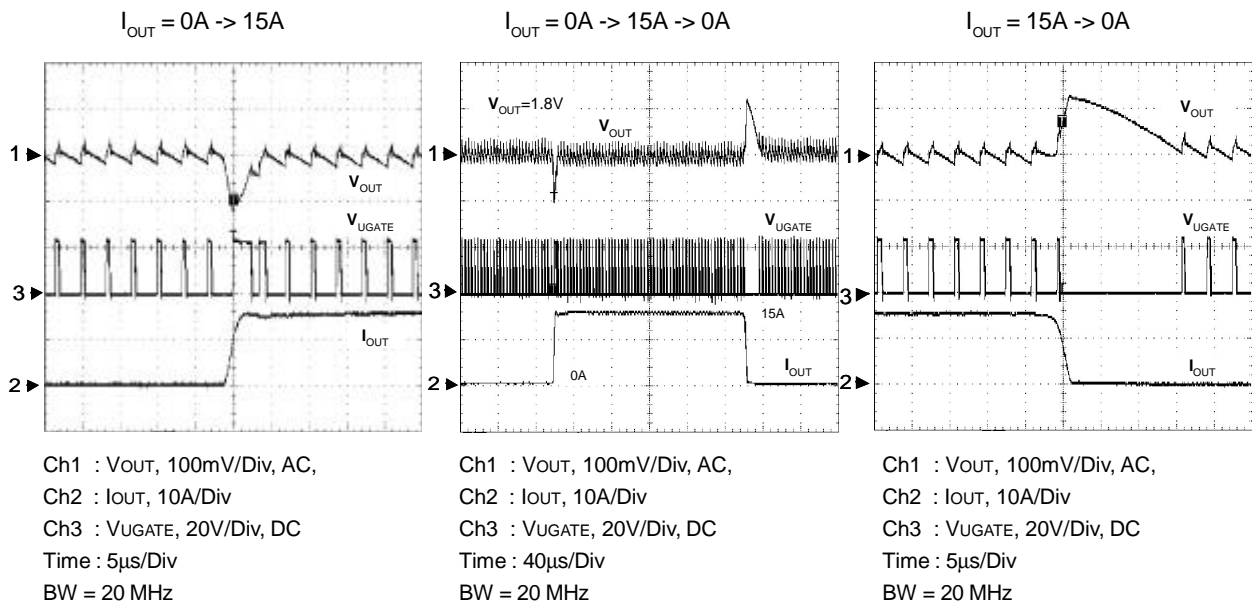

Operating Waveforms (Cont.)

(Refer to the typical application circuit, $V_{BIAS}=V_{IN}=+12V$ supplied by an ATX Power Supply)

2. UGATE and LGATE Switching Waveforms

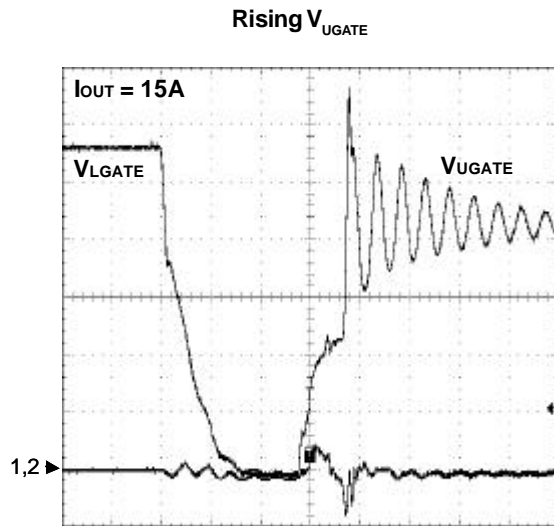

Ch1 : V_{UGATE} , 5V/Div, DC Ch2 : V_{LGATE} , 2V/Div, DC
Time : 20ns/Div BW = 500 MHz

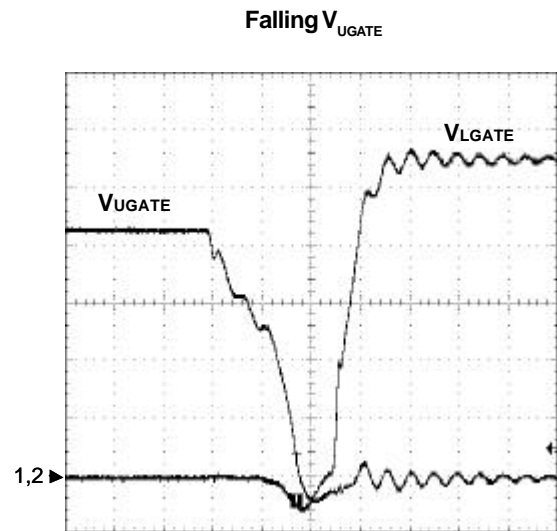

Ch1 : V_{UGATE} , 5V/Div, DC Ch2 : V_{LGATE} , 2V/Div, DC
Time : 20ns/Div BW = 500 MHz

3. Powering ON / OFF

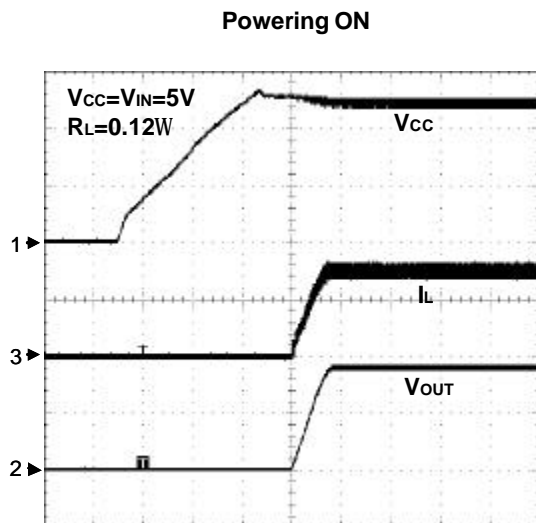

Ch1 : V_{cc} , 2V/Div, DC Ch2 : V_{out} , 1V/Div, DC
Ch3 : I_L , 10A/Div, DC Time : 5ms/Div
BW = 20 MHz

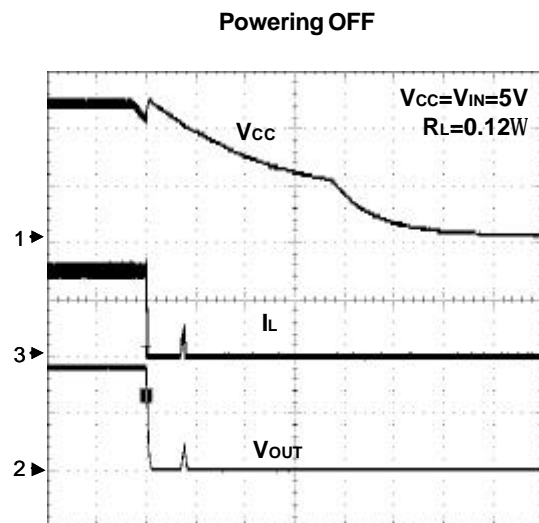

Ch1 : V_{cc} , 2V/Div, DC Ch2 : V_{out} , 1V/Div, DC
Ch3 : I_L , 10A/Div, DC Time : 10ms/Div
BW = 20 MHz

Operating Waveforms (Cont.)

(Refer to the typical application circuit, $V_{BIAS}=V_{IN}=+12V$ supplied by an ATX Power Supply)

3. Powering ON / OFF (Cont.)

Powering ON

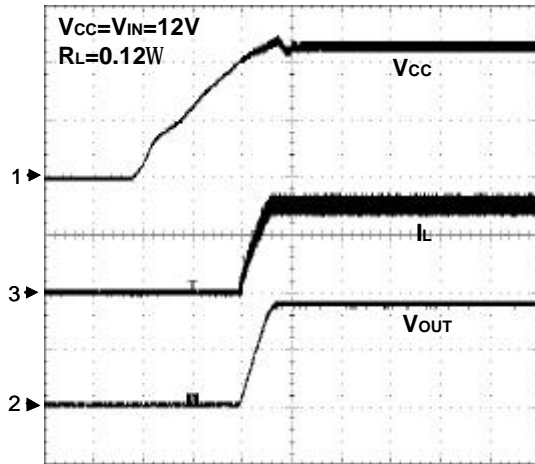

Ch1 : Vcc, 5V/Div, DC
Ch2 : Vout, 1V/Div, DC
Ch3 : IL, 10A/Div, DC
Time : 5ms/Div
BW = 20 MHz

Powering OFF

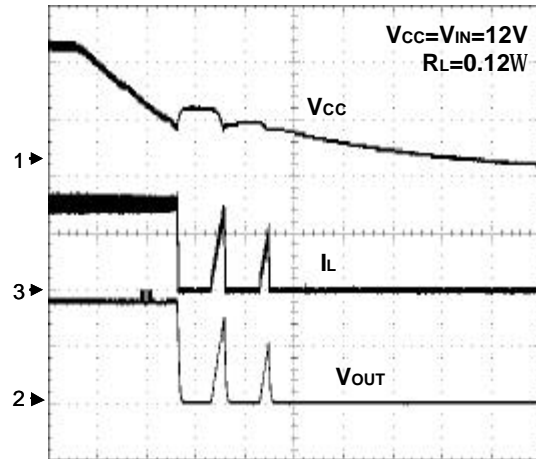

Ch1 : Vcc, 5V/Div, DC
Ch2 : Vout, 1V/Div, DC
Ch3 : IL, 10A/Div, DC
Time : 10ms/Div
BW = 20 MHz

4. Enabling and Shutting Down

Enabling by Releasing OCSET Pin

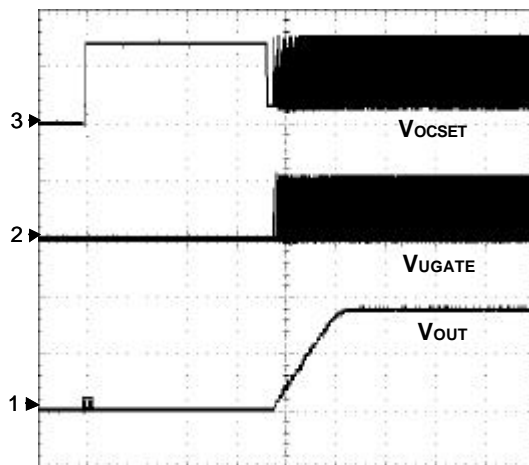

Ch1 : Vout, 1V/Div, DC
Ch2 : VUGATE, 20V/Div, DC
Ch3 : VocSET, 2V/Div, DC
Time : 2ms/Div
BW = 20 MHz

Shutting Down by Pulling OCSET Low

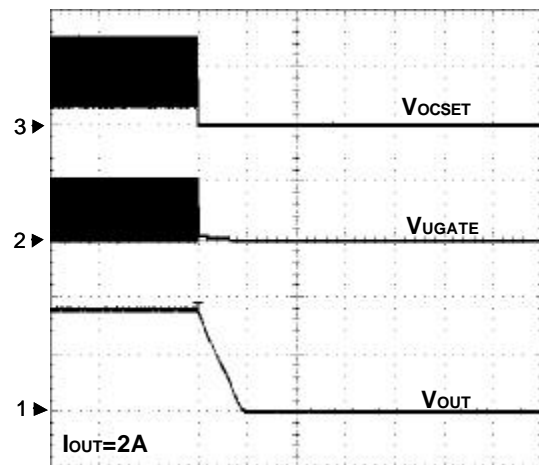

Ch1 : Vout, 1V/Div, DC
Ch2 : VUGATE, 20V/Div, DC
Ch3 : VocSET, 2V/Div, DC
Time : 2ms/Div
BW = 20 MHz

Operating Waveforms (Cont.)

(Refer to the typical application circuit, $V_{BIAS}=V_{IN}=+12V$ supplied by an ATX Power Supply)

5. Over-Current Protection

No Connecting a shutdown MOSFET
at OCSET Pin

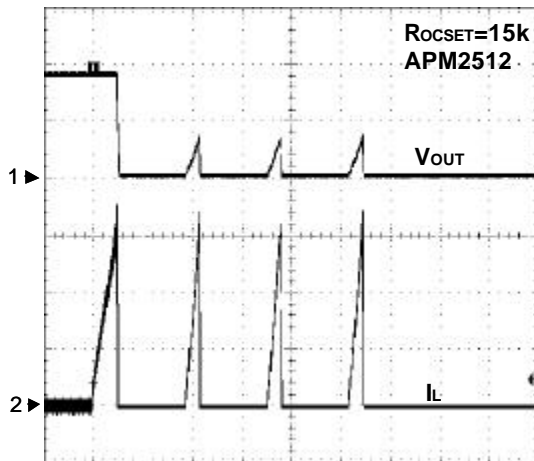

Ch1 : Vout, 1V/Div, DC Ch2 : IL, 10A/Div, DC
Time : 5ms/Div BW = 20 MHz

Connecting a shutdown MOSFET
(2N7002) at OCSET Pin

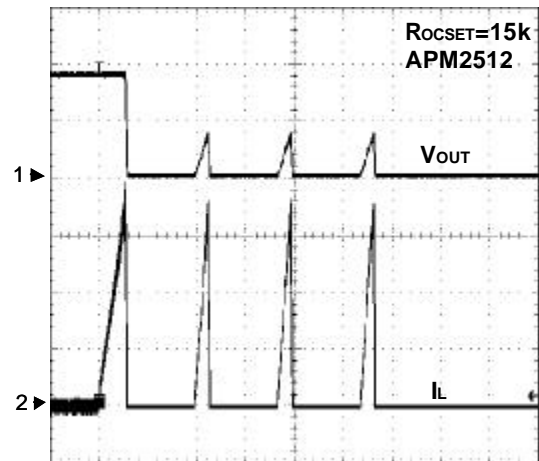

Ch1 : Vout, 1V/Div, DC Ch2 : IL, 10A/Div, DC
Time : 5ms/Div BW = 20 MHz

6. OCSET Voltage RC Delay

No Connecting a shutdown MOSFET
at OCSET Pin

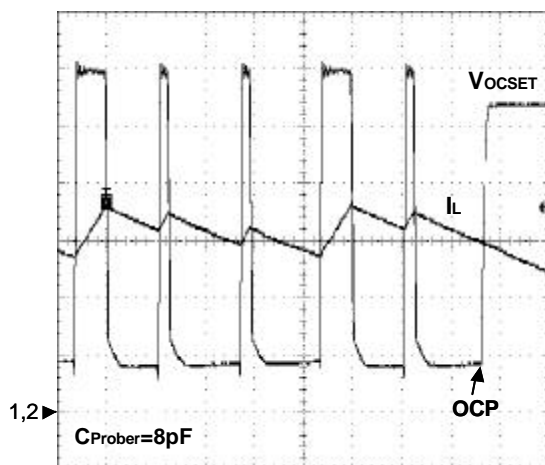

Ch1 : Vocset, 0.5V/Div, DC Ch2 : IL, 10A/Div, DC
Time : 2µS/Div BW = 20 MHz

Connecting a shutdown MOSFET
(2N7002) at OCSET Pin

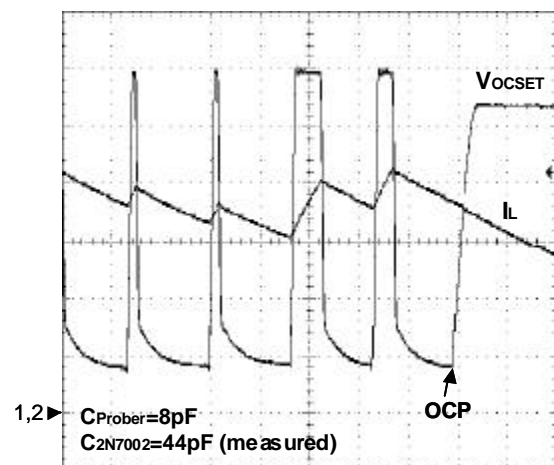

Ch1 : Vocset, 0.5V/Div, DC Ch2 : IL, 10A/Div, DC
Time : 2µS/Div BW = 20 MHz

Operating Waveforms (Cont.)

(Refer to the typical application circuit, $V_{BIAS}=V_{IN}=+12V$ supplied by an ATX Power Supply)

6. OCSET Voltage RC Delay (Cont.)

Connecting a shutdown MOSFET (APM2322) at OCSET Pin

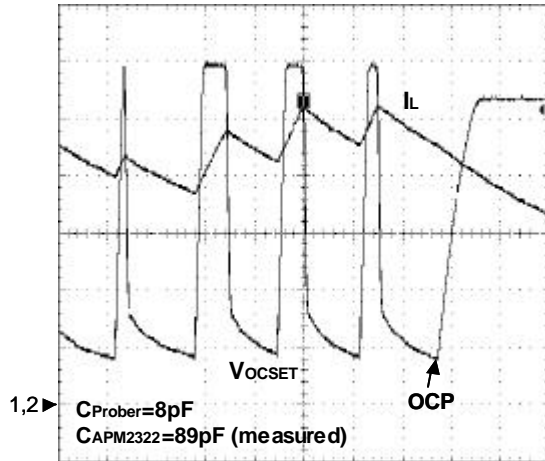

Ch1 : VOCSET, 0.5V/Div, DC Ch2 : IL, 10A/Div, DC
Time : 2 μ S/Div BW = 20 MHz

7. Short-Circuit Test

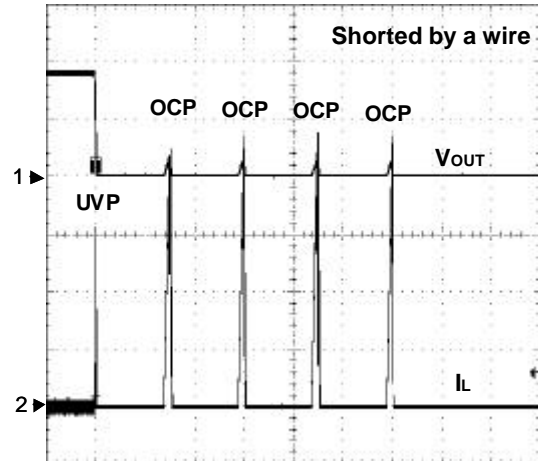

Ch1 : Vout, 1V/Div, DC Ch2 : IL, 10A/Div, DC
Time : 5ms/Div BW = 20 MHz

Function Description

Power-On-Reset (POR)

The APW7120A monitors the VCC voltage (V_{CC}) for Power-On-Reset function, preventing wrong logic operation during powering on. When the VCC voltage is ready, the APW7120A starts a start-up process and then ramps the output voltage up to the target voltage.

Soft-Start

The APW7120A has a built-in digital soft-start to control the output voltage rise and limit the current surge at the start-up. During soft-start, an internal ramp connected to the one of the positive inputs of the Gm amplifier rises up from 0V to 2V to replace the reference voltage (0.8V) until the ramp voltage reaches the reference

voltage. The soft-start interval is about 3.2ms typical, independent of the converter's input and output voltages.

Over-Current Protection (OCP)

The over-current function protects the switching converter against over-current or short-circuit conditions. The controller senses the inductor current by detecting the drain-to-source voltage, product of the inductor's current and the on-resistance, of the low-side MOSFET during it's on-state. This method enhances the converter's efficiency and reduces cost by eliminating a current sensing resistor.

A resistor (R_{OCSET}), connected from the OCSET to the

Function Description (Cont.)

Over-Current Protection (OCP) (Cont.)

low-side MOSFET's drain, programs the over-current trip level. An internal 40 μ A (typical) current source flowing through the R_{OCSET} develops a voltage (V_{ROCSET}) across the R_{OCSET} . When the V_{OCSET} ($V_{ROCSET} + V_{DS}$ of the low-side MOSFET) is less than the internal over-current reference voltage (0.4V, typical), the IC shuts off the converter and then initiates a new soft-start process. After 4 over-current events are counted, the device turns off both high-side and low-side MOSFETs and the converter's output is latched to be floating.

Please pay attention to the RC delay effect. It causes the OCP trip level to be the function of the operating duty. The parasitic capacitance (including the capacitance inside the OCSET, external PCB trace capacitance and the C_{OSS} of the shutdown MOSFET) must be minimized, especially selecting a shutdown MOSFET with very small C_{OSS} . The OCP trip level follows the duty to increase a little at low operating duty, but very much at high operating duty, like the RC delay curve. Due to load regulation or current-limit, heavy load normally reduces converter's input voltage and increases the power losses. During heavy load, the APW7120A regulates the output voltage by expending the duty. This rises up the OCP trip level at the same time.

Under-Voltage Protection (UVP)

The under-voltage function monitors the FB voltage (V_{FB}) to protect the converter against short-circuit conditions. When the V_{FB} falls below the falling UVP threshold ($67\% V_{REF}$), the APW7120A shuts off the converter. After a preceding delay, which starts at the beginning of the under-voltage shutdown, the APW7120A initiates a new soft-start to resume regulating. The under-voltage protection shuts off and then re-starts the converter repeatedly without

latching. The function is disabled during soft-start process.

Over-Voltage Protection (OVP)

The over-voltage protection monitors the FB voltage to prevent the output from over-voltage. When the output voltage rises to 118% of the nominal output voltage, the APW7120A turns on the low-side MOSFET until the output voltage falls below the OVP threshold, regulating the output voltage around the OVP thresholds.

Adaptive Shoot-Through Protection

The gate driver incorporates adaptive shoot-through protection to high-side and low-side MOSFETs from conducting simultaneously and shorting the input supply. This is accomplished by ensuring the falling gate has turned off one MOSFET before the other is allowed to rise.

During turn-off of the low-side MOSFET, the LGATE voltage is monitored until it reaches a 1.5V threshold, at which time the UGATE is released to rise after a constant delay. During turn-off of the high-side MOSFET, the UGATE-to-PHASE voltage is also monitored until it reaches a 1.5V threshold, at which time the LGATE is released to rise after a constant delay.

Shutdown Control

Pulling the OCSET voltage below 0.15V by an open drain transistor, shown in typical application circuit, shuts down the APW7120A PWM controller. In shutdown mode, the UGATE and LGATE are pulled to PHASE and GND respectively, the output is floating.

Application Information

Input Capacitor Selection

Use small ceramic capacitors for high frequency decoupling and bulk capacitors to supply the surge current needed each time high-side MOSFET(Q1) turns on. Place the small ceramic capacitors physically close to the MOSFETs and between the drain of Q1 and the source of low-side MOSFET(Q2).

The important parameters for the bulk input capacitor are the voltage rating and the RMS current rating. For reliable operation, select the bulk capacitor with voltage and current ratings above the maximum input voltage and largest RMS current required by the circuit. The capacitor voltage rating should be at least 1.25 times greater than the maximum input voltage and a voltage rating of 1.5 times is a conservative guideline. The RMS current of the bulk input capacitor is calculated as the following equation :

$$I_{RMS} = I_{OUT} \cdot \sqrt{D \cdot (1 - D)} \quad (A)$$

For a through hole design, several electrolytic capacitors may be needed. For surface mount designs, solid tantalum capacitors can be used, but caution must be exercised with regard to the capacitor surge current rating.

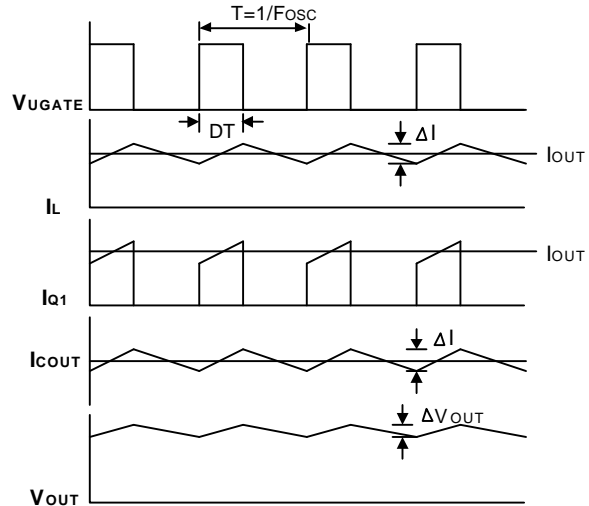
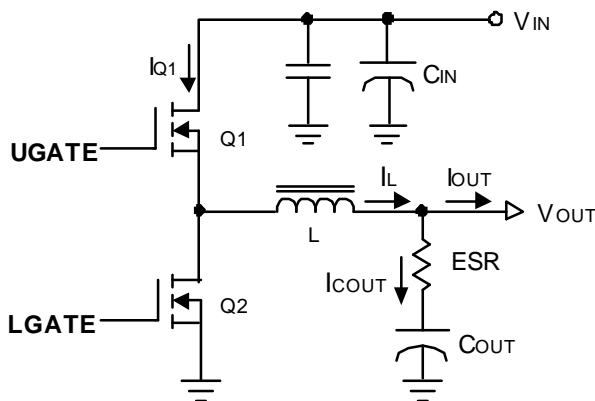

Figure 1 Buck Converter Waveforms

Output Capacitor Selection

An output capacitor is required to filter the output and supply the load transient current. The filtering requirements are a function of the switching frequency and the ripple current. The output ripple is the sum of the voltages, having phase shift, across the ESR and the ideal output capacitor. The peak-to-peak voltage of the ESR is calculated as the following equations :

$$V_{OUT} = D \cdot V_{IN} \quad (V) \dots\dots\dots (1)$$

$$\Delta I = \frac{V_{OUT} \cdot (1 - D)}{F_{OSC} \cdot L} \quad (A) \dots\dots\dots (2)$$

$$V_{ESR} = \Delta I \cdot ESR \quad (V) \dots\dots\dots (3)$$

The peak-to-peak voltage of the ideal output capacitor is calculated as the following equation :

$$\Delta V_{COUT} = \frac{\Delta I}{8 \cdot F_{OSC} \cdot C_{OUT}} \quad (V) \dots\dots\dots (4)$$

For general applications using bulk capacitors, the ΔV_{COUT} is much smaller than the V_{ESR} and can be ignored. Therefore, the AC peak-to-peak output voltage is shown below:

$$\Delta V_{OUT} = \Delta I \cdot ESR \quad (V) \dots\dots\dots (5)$$

The load transient requirements are the function of

Application Information (Cont.)

Output Capacitor Selection (Cont.)

the slew rate (di/dt) and the magnitude of the transient load current. These requirements are generally met with a mix of capacitors and careful layout. Modern components and loads are capable of producing transient load rates above 1A/ns. High frequency capacitors initially supply the transient and slow the current load rate seen by the bulk capacitors. The bulk filter capacitor values are generally determined by the ESR (Effective Series Resistance) and voltage rating requirements rather than actual capacitance requirements.

High frequency decoupling capacitors should be placed as close to the power pins of the load as physically possible. Be careful not to add inductance in the circuit board wiring that could cancel the usefulness of these low inductance components.

An aluminum electrolytic capacitor's ESR value is related to the case size with lower ESR available in larger case sizes. However, the Equivalent Series Inductance (ESL) of these capacitors increases with case size and can reduce the usefulness of the capacitor to high slew-rate transient loading. In most cases, multiple electrolytic capacitors of small case size perform better than a single large case capacitor.

Output Inductor Selection

The output inductor is selected to meet the output voltage ripple requirements and minimize the converter's response time to the load transient. The inductor value determines the converter's ripple current and the ripple voltage, see equations (2) and (5). Increasing the value of inductance reduces the ripple current and voltage. However, the large inductance values reduce the converter's response time to a load transient.

One of the parameters limiting the converter's response

to a load transient is the time required to change the inductor current. Given a sufficiently fast control loop design, the APW7120A will provide either 0% or 85% (Average) duty cycle in response to a load transient. The response time is the time required to slew the inductor current from an initial current value to the transient current level. During this interval the difference between the inductor current and the transient current level must be supplied by the output capacitor. Minimizing the response time can minimize the output capacitance required.

The response time to a transient is different for the application of load and the removal of load. The following equations give the approximate response time interval for application and removal of a transient load:

$$t_{\text{RISE}} = \frac{L \cdot I_{\text{TRAN}}}{V_{\text{IN}} - V_{\text{OUT}}}, \quad t_{\text{FALL}} = \frac{L \cdot I_{\text{TRAN}}}{V_{\text{OUT}}}$$

where: I_{TRAN} is the transient load current step, t_{RISE} is the response time to the application of load, and t_{FALL} is the response time to the removal of load. The worst case response time can be either at the application or removal of load. Be sure to check both of these equations at the transient load current. These requirements are minimum and maximum output levels for the worst case response time.

MOSFET Selection

The APW7120A requires two N-Channel power MOSFETs. These should be selected based upon $R_{\text{DS(ON)}}$, gate supply requirements, and thermal management requirements.

In high-current applications, the MOSFET power dissipation, package selection and heatsink are the dominant design factors. The power dissipation includes two loss components, conduction loss and switching loss. The conduction losses are the largest component of power dissipation for both the high-side and the

Application Information (Cont.)

MOSFET Selection (Cont.)

low-side MOSFETs. These losses are distributed between the two MOSFETs according to duty factor (see the equations below). Only the high-side MOSFET has switching losses, since the low-side MOSFETs body diode or an external Schottky rectifier across the lower MOSFET clamps the switching node before the synchronous rectifier turns on. These equations assume linear voltage-current transitions and do not adequately model power loss due the reverse-recovery of the low-side MOSFET's body diode. The gate-charge losses are dissipated by the APW7120A and don't heat the MOSFETs. However, large gate-charge increases the switching interval, t_{sw} which increases the high-side MOSFET switching losses. Ensure that both MOSFETs are within their maximum junction temperature at high ambient temperature by calculating the temperature rise according to package thermal-resistance specifications. A separate heatsink may be necessary depending upon MOSFET power, package type, ambient temperature and air flow.

$$P_{High-Side} = I_{OUT}^2 \cdot R_{DS(on)} \cdot D + \frac{1}{2} \cdot I_{OUT} \cdot V_{IN} \cdot t_{sw} \cdot F_{OSC}$$

$$P_{Low-Side} = I_{OUT}^2 \cdot R_{DS(on)} \cdot (1-D)$$

Where : t_{sw} is the switching interval

Feedback Compensation

The figure 2 shows the control system of the APW7120, which consists of an internal voltage-mode PWM modulator, an output L-C filter, a resistor-divider and an internal compensation network. The R and C are the equivalent series resistance(ESR) and capacitance of the output capacitor; the L is the inductance of the output inductor.

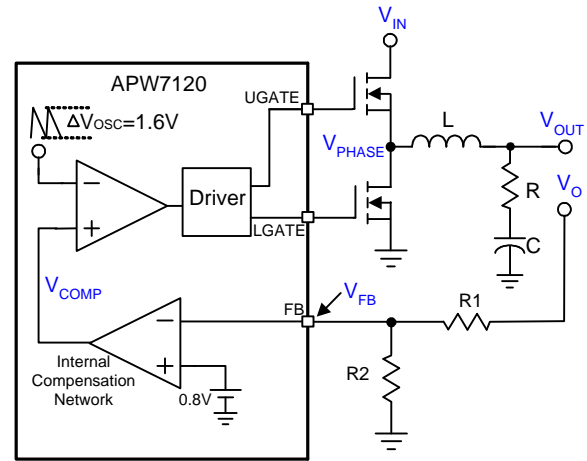

Figure 2. APW7120 Control System

The transfer functions are defined as following :

$$A1(S) = \frac{V_{FB}(S)}{V_O(S)} = \frac{R2}{R1+R2}$$

$$A2(S) = \frac{V_{COMP}(S)}{V_{FB}(S)} \quad (\text{Internal Compensation})$$

$$A3(S) = \frac{V_{PHASE}(S)}{V_{COMP}(S)} = \frac{V_{IN}}{\Delta V_{OSC}}$$

$$A4(S) = \frac{V_{OUT}(S)}{V_{PHASE}(S)} = \frac{R \cdot C \cdot S + 1}{L \cdot C \cdot S^2 + R \cdot C \cdot S + 1}$$

$$\begin{aligned} A_{CL}(S) &= \frac{V_{OUT}(S)}{V_O(S)} \\ &= \frac{V_{FB}(S)}{V_O(S)} \cdot \frac{V_{COMP}(S)}{V_{FB}(S)} \cdot \frac{V_{PHASE}(S)}{V_{COMP}(S)} \cdot \frac{V_{OUT}(S)}{V_{PHASE}(S)} \\ &= A1(S) \cdot A2(S) \cdot A3(S) \cdot A4(S) \end{aligned}$$

where $A1(S)$ is the transfer function of the resistor-divider, $A2(S)$ is the transfer function of the feedback compensation network, $A3(S)$ is the transfer function of the PWM modulator, $A4(S)$ is the transfer function of the output LC filter, and $A_{CL}(S)$ is the transfer function of the closed-loop control system. Refer to figure 3. The Pole and Zero frequencies of the $A1(S)$, $A2(S)$, $A3(S)$, and $A_{CL}(S)$ are shown or calculated as the following equations:

$$F_{ZA21} = 0.4\text{kHz} \quad (F_Z) \qquad F_{PA21} = 430\text{kHz} \quad (F_{P2})$$

$$F_{PA41,2} = \frac{1}{2\pi \times \sqrt{LC}} \qquad F_{ZA41} = \frac{1}{2\pi \times R \times C}$$

Application Information (Cont.)

Feedback Compensation (Cont.)

where the F_{PA21} (or F_{P2}) and F_{ZA21} (or F_z) are the Pole and Zero frequencies of the A2(S), the $F_{PA41,2}$ and F_{ZA41} are the double-Pole and Zero frequencies of the A4 (S), the V_{IN} is the input voltage of the PWM converter and the load resistance of the converter is very large. For good converter stability, the values of the L, C, and R must be selected to meet the following criteria:

1. Make sure the double-pole frequency ($F_{PA41,2}$) of the output filter is bigger than the zero frequency (F_{ZA21}) of the internal compensation network.

2. The following equation must be true:

$$\log\left(\frac{V_{IN}}{\Delta V_{OSC}}\right) + \log\left(\frac{R2}{R1+R2}\right) - 2 \cdot \log\left(\frac{1}{R} \cdot \sqrt{\frac{L}{C}}\right) + 1.2 > 0$$

3. The converter crossover frequency (F_{CO}) must be in the range of 10%~30% of minimum F_{OSC} of the converter. The F_{CO} is calculated by using the following equations:

$$10\% F_{OSC_MN} \leq \left(F_{CO} = 10^{\frac{\text{Gain at FZA41}}{20} \cdot F_{ZA41}} \right) \leq 30\% F_{OSC_MN}$$

$$\begin{aligned} \text{Gain at FZA41} &= 20 \cdot \log\left(\frac{V_{IN}}{\Delta V_{OSC}}\right) + 20 \cdot \log\left(\frac{R2}{R1+R2}\right) \\ &\quad - 40 \cdot \log\left(\frac{1}{R} \cdot \sqrt{\frac{L}{C}}\right) + 27 \end{aligned}$$

4. The values of L, C, and R selected must meet the equations above over the operating temperature, voltage, and current ranges.

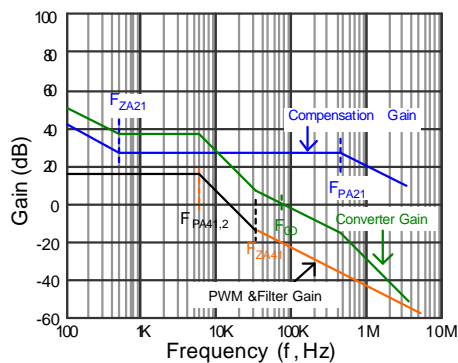

Figure 3. Converter Gain vs. Frequency

Layout Consideration

In high power switching regulator, a correct layout is important to ensure proper operation of the regulator. In general, interconnecting impedances should be minimized by using short, wide printed circuit traces. Signal and power grounds are to be kept separate and finally combined using ground plane construction or single point grounding. Figure 4 illustrates the layout, with bold lines indicating high current paths. Components along the bold lines should be placed close together. Below is a checklist for your layout:

1. Begin the layout by placing the power components first. Orient the power circuitry to achieve a clean power flow path. If possible, make all the connections on one side of the PCB with wide, copper filled areas.
2. Connect the ground of feedback divider directly to the GND pin of the IC using a dedicated ground trace.
3. The VCC decoupling capacitor should be right next to the VCC and GND pins. Capacitor C_{BOOT} should be connected as close to the BOOT and PHASE pins as possible.
4. Minimize the length and increase the width of the trace between UGATE/LGATE and the gates of the MOSFETs to reduce the impedance driving the MOSFETs.
5. Use a dedicated trace to connect the R_{OCSET} and the Drain pad of the low-side MOSFET, Kevin connection, for accurate current sensing.
6. Keep the switching nodes (UGATE, LGATE, and PHASE) away from sensitive small signal nodes since these nodes are fast moving signals. Therefore, keep traces to these nodes as short as possible.
7. Place the decoupling ceramic capacitor C_{HF} near the Drain of the high-side MOSFET as close as possible. The bulk capacitors C_{IN} are also placed near the Drain.

Application Information (Cont.)

Layout Consideration (Cont.)

8. Place the Source of the high-side MOSFET and the Drain of the low-side MOSFET as close as possible. Minimizing the impedance with wide layout plane between the two pads reduces the voltage bounce of the node.

9. Use a wide power ground plane, with low impedance, to connect the C_{HF} , C_{IN} , C_{OUT} , Schottky diode and the Source of the low-side MOSFET to provide a low impedance path between the components for large and high frequency switching currents.

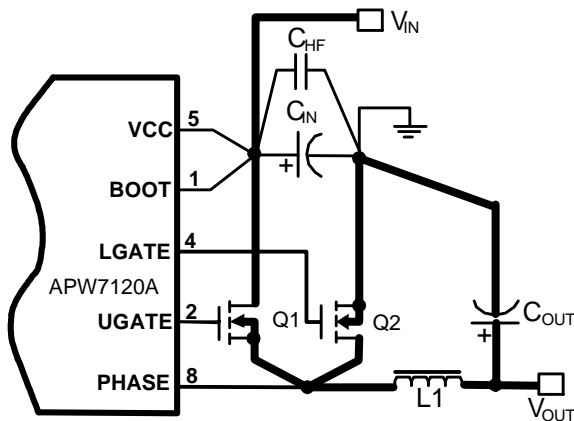
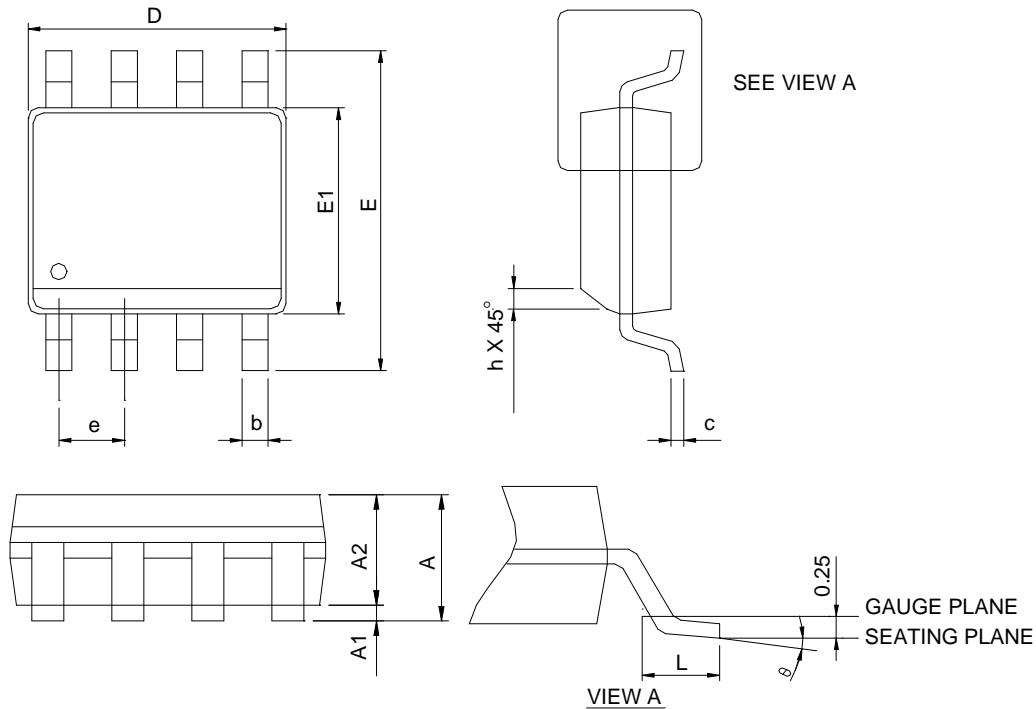

Figure 4. Recommended Layout Diagram

Package Information

SOP-8



SYMBOL	SOP-8			
	MILLIMETERS		INCHES	
	MIN.	MAX.	MIN.	MAX.
A		1.75		0.069
A1	0.10	0.25	0.004	0.010
A2	1.25		0.049	
b	0.31	0.51	0.012	0.020
c	0.17	0.25	0.007	0.010
D	4.80	5.00	0.189	0.197
E	5.80	6.20	0.228	0.244
E1	3.80	4.00	0.150	0.157
e	1.27 BSC		0.050 BSC	
h	0.25	0.50	0.010	0.020
L	0.40	1.27	0.016	0.050
θ	0°	8°	0°	8°

- Note: 1. Follow JEDEC MS-012 AA.
 2. Dimension "D" does not include mold flash, protrusions or gate burrs. Mold flash, protrusion or gate burrs shall not exceed 6 mil per side.
 3. Dimension "E" does not include inter-lead flash or protrusions. Inter-lead flash and protrusions shall not exceed 10 mil per side.

Carrier Tape & Reel Dimensions

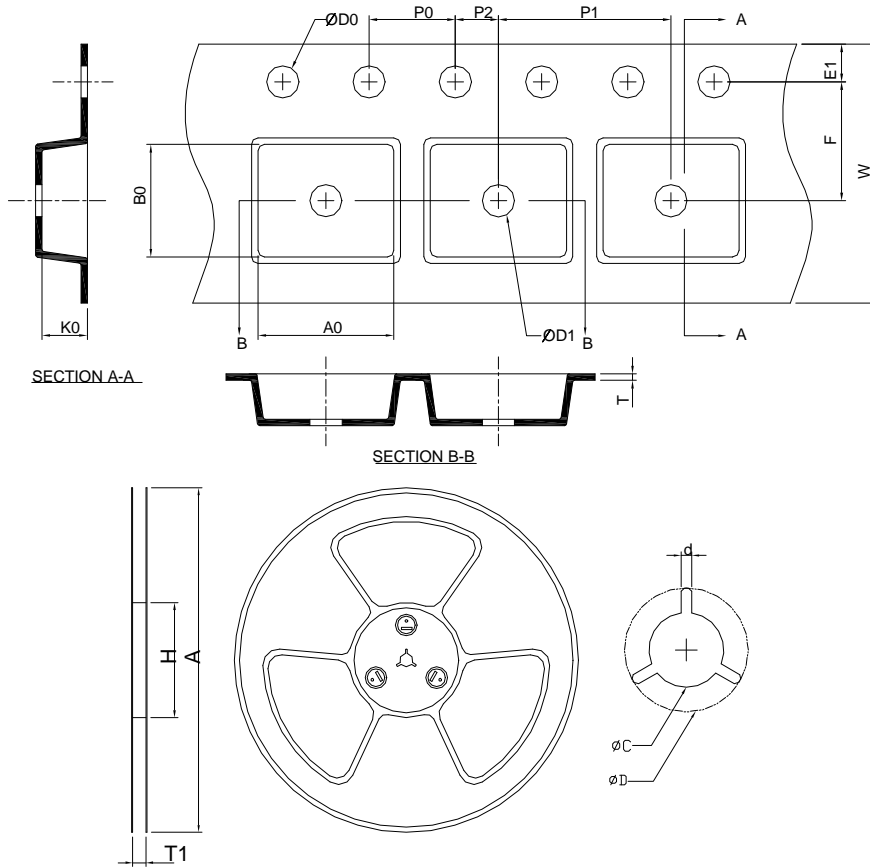

Application	A	H	T1	C	d	D	W	E1	F
SOP-8	330.0 ±2.00	50 MIN.	12.4+2.00 -0.00	13.0+0.50 -0.20	1.5 MIN.	20.2 MIN.	12.0 ±0.30	1.75 ±0.10	5.5 ±0.05
	P0	P1	P2	D0	D1	T	A0	B0	K0
	4.0 ±0.10	8.0 ±0.10	2.0 ±0.05	1.5+0.10 -0.00	1.5 MIN.	0.6+0.00 -0.40	6.40 ±0.20	5.20 ±0.20	2.10 ±0.20

(mm)

Devices Per Unit

Package Type	Unit	Quantity
SOP-8	Tape & Reel	2500

Reflow Condition (IR/Convection or VPR Reflow)

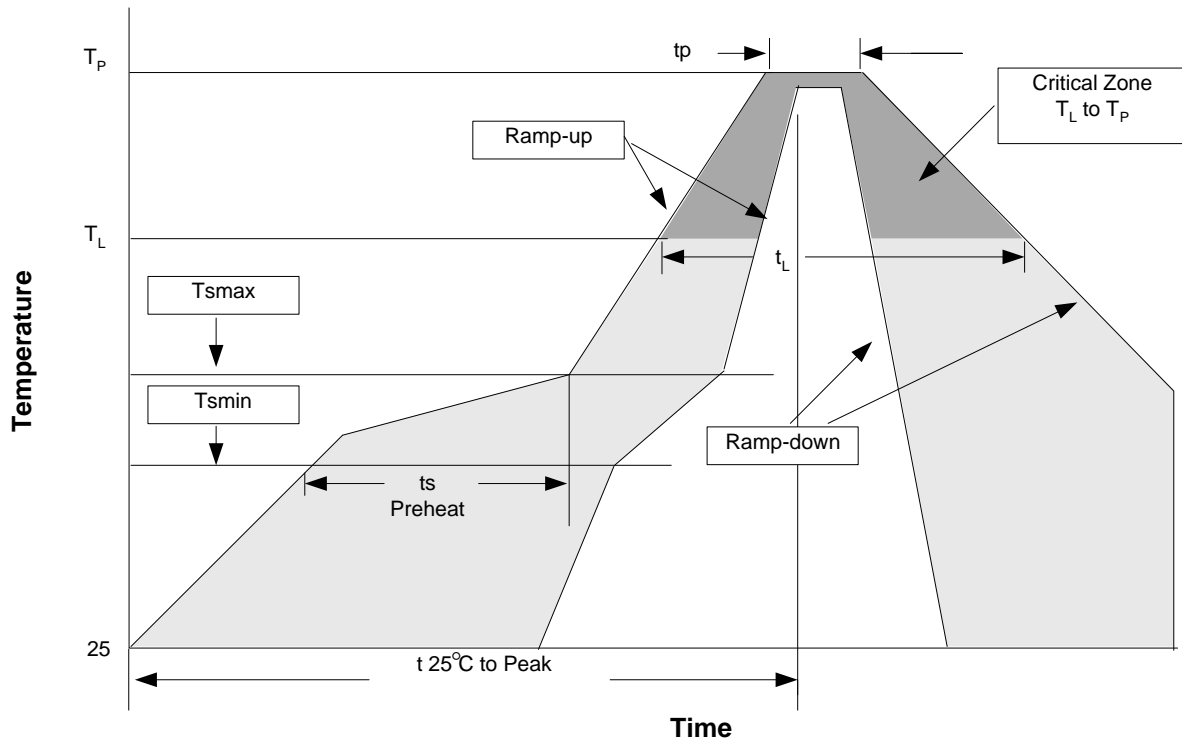

Reliability Test Program

Test item	Method	Description
SOLDERABILITY	MIL-STD-883D-2003	245°C, 5 sec
HOLT	MIL-STD-883D-1005.7	1000 Hrs Bias @125°C
PCT	JESD-22-B, A102	168 Hrs, 100%RH, 121°C
TST	MIL-STD-883D-1011.9	-65°C~150°C, 200 Cycles
ESD	MIL-STD-883D-3015.7	VHBM > 2KV, VMM > 200V
Latch-Up	JESD 78	10ms, I _{tr} > 100mA

Classification Reflow Profiles

Profile Feature	Sn-Pb Eutectic Assembly	Pb-Free Assembly
Average ramp-up rate (T _L to T _p)	3°C/second max.	3°C/second max.
Preheat		
- Temperature Min (T _{Amin})	100°C	150°C
- Temperature Max (T _{smax})	150°C	200°C
- Time (min to max) (ts)	60-120 seconds	60-180 seconds
Time maintained above:		
- Temperature (T _L)	183°C	217°C
- Time (t _L)	60-150 seconds	60-150 seconds
Peak/Classification Temperature (T _p)	See table 1	See table 2
Time within 5°C of actual Peak Temperature (tp)	10-30 seconds	20-40 seconds
Ramp-down Rate	6°C/second max.	6°C/second max.
Time 25°C to Peak Temperature	6 minutes max.	8 minutes max.

Note: All temperatures refer to topside of the package. Measured on the body surface.

Classification Reflow Profiles (Cont.)

Table 1. SnPb Eutectic Process – Package Peak Reflow Temperatures

Package Thickness	Volume mm ³ <350	Volume mm ³ ≥350
<2.5 mm	240 +0/-5°C	225 +0/-5°C
≥2.5 mm	225 +0/-5°C	225 +0/-5°C

Table 2. Pb-free Process – Package Classification Reflow Temperatures

Package Thickness	Volume mm ³ <350	Volume mm ³ 350-2000	Volume mm ³ >2000
<1.6 mm	260 +0°C*	260 +0°C*	260 +0°C*
1.6 mm – 2.5 mm	260 +0°C*	250 +0°C*	245 +0°C*
≥2.5 mm	250 +0°C*	245 +0°C*	245 +0°C*

* Tolerance: The device manufacturer/supplier **shall** assure process compatibility up to and including the stated classification temperature (this means Peak reflow temperature +0°C. For example 260°C+0°C) at the rated MSL level.

Customer Service

Anpec Electronics Corp.

Head Office :

No.6, Dusing 1st Road, SBIP,
Hsin-Chu, Taiwan, R.O.C.
Tel : 886-3-5642000
Fax : 886-3-5642050

Taipei Branch :

2F, No. 11, Lane 218, Sec 2 Jhongsing Rd.,
Sindian City City, Taipei County 23146, Taiwan
Tel : 886-2-2910-3838
Fax : 886-2-2917-3838