

SUN2000-(50KTL, 60KTL)-M0

User Manual

Issue **04**
Date **2018-07-30**

Copyright © Huawei Technologies Co., Ltd. 2019. All rights reserved.

No part of this document may be reproduced or transmitted in any form or by any means without prior written consent of Huawei Technologies Co., Ltd.

Trademarks and Permissions



HUAWEI and other Huawei trademarks are trademarks of Huawei Technologies Co., Ltd.

All other trademarks and trade names mentioned in this document are the property of their respective holders.

Notice

The purchased products, services and features are stipulated by the contract made between Huawei and the customer. All or part of the products, services and features described in this document may not be within the purchase scope or the usage scope. Unless otherwise specified in the contract, all statements, information, and recommendations in this document are provided "AS IS" without warranties, guarantees or representations of any kind, either express or implied.

The information in this document is subject to change without notice. Every effort has been made in the preparation of this document to ensure accuracy of the contents, but all statements, information, and recommendations in this document do not constitute a warranty of any kind, express or implied.

Huawei Technologies Co., Ltd.

Address: Huawei Industrial Base
Bantian, Longgang
Shenzhen 518129
People's Republic of China

Website: <http://e.huawei.com>

About This Document

Purpose





This document describes the SUN2000-50KTL-M0 and SUN2000-60KTL-M0 (SUN2000 for short) in terms of its installation, electrical connections, commissioning, maintenance, and troubleshooting. Before installing and operating the SUN2000, ensure that you are familiar with the features, functions, and safety precautions provided in this document.

Intended Audience

This document is intended for photovoltaic (PV) plant personnel and electrical technicians.

Symbol Conventions

The symbols that may be found in this document are defined as follows.

Symbol	Description
	Indicates an imminently hazardous situation which, if not avoided, will result in death or serious injury.
	Indicates a potentially hazardous situation which, if not avoided, could result in death or serious injury.
	Indicates a potentially hazardous situation which, if not avoided, may result in minor or moderate injury.
	Indicates a potentially hazardous situation which, if not avoided, could result in equipment damage, data loss, performance deterioration, or unanticipated results. NOTICE is used to address practices not related to personal injury.

Symbol	Description
 NOTE	<p>Calls attention to important information, best practices and tips.</p> <p>NOTE is used to address information not related to personal injury, equipment damage, and environment deterioration.</p>

Change History

Changes between document issues are cumulative. The latest document issue contains all updates made in previous issues.

Issue 04 (2018-07-30)

Updated [5.4 Installing the AC Output Power Cable](#).

Updated [7.2.1.3 Setting Feature Parameters](#).

Updated [8.2 Troubleshooting](#).

Issue 03 (2018-06-06)

Updated [6.3 \(Optional\) 4G Communication Commissioning](#).

Issue 02 (2018-04-16)

Added description about the SUN2000-50KTL-M0.

Issue 01 (2017-11-30)

This issue is used for first office application (FOA).

Contents

About This Document	ii
1 Safety Precautions	1
2 Overview	4
2.1 Introduction	4
2.2 Appearance	5
2.3 Label Description.....	8
2.3.1 Enclosure Labels.....	8
2.3.2 Product Nameplate.....	10
2.4 Working Principles.....	11
2.4.1 Conceptual Diagram	11
2.4.2 Working Modes.....	12
3 Storage	14
4 Installation	15
4.1 Checking Before Installation	15
4.2 Tools	16
4.3 Determining the Installation Position	17
4.3.1 Environment Requirements	17
4.3.2 Space Requirements.....	18
4.4 Installing the Mounting Bracket	21
4.4.1 Support-mounted Installation	21
4.4.2 Wall-mounted Installation.....	24
4.5 Installing the SUN2000	26
5 Electrical Connections	31
5.1 Precautions.....	31
5.2 Crimping the OT Terminal.....	31
5.3 Opening the Maintenance Compartment Door	33
5.4 Installing the AC Output Power Cable.....	36
5.5 Connecting DC Input Power Cables	43
5.6 Installing the Communications Cable	49
5.6.1 Communication Mode Description.....	49
5.6.2 Installing the RS485 Communications Cable	51

5.6.2.1 Terminal Block Connection	51
5.6.2.2 Connecting Cables to the RJ45 Network Port	55
5.7 Closing the Maintenance Compartment Door	58
6 Commissioning.....	60
6.1 Checking Before Power-On	60
6.2 Powering On the SUN2000	60
6.3 (Optional) 4G Communication Commissioning	66
6.4 Powering Off the System	70
7 Man-Machine Interactions	71
7.1 Operations with a USB Flash Drive.....	71
7.1.1 Exporting Configurations	71
7.1.2 Importing Configuration	73
7.1.3 Exporting Data.....	74
7.1.4 Upgrading	74
7.2 Operations with the SUN2000 App	76
7.2.1 Operations Related to the Advanced User	76
7.2.1.1 Setting Grid Parameters	76
7.2.1.2 Setting Protect Parameters	77
7.2.1.3 Setting Feature Parameters	78
7.2.2 Operations Related to the Special User.....	86
7.2.2.1 Setting Grid Parameters	86
7.2.2.2 Setting Protection Parameters	89
7.2.2.3 Setting Feature Parameters	91
7.2.2.4 Setting Power Adjustment Parameters	94
8 Maintenance	98
8.1 Routine Maintenance	98
8.2 Troubleshooting	99
9 Handling the Inverter.....	106
9.1 Removing the SUN2000.....	106
9.2 Packing the SUN2000.....	106
9.3 Disposing of the SUN2000	106
10 Technical Specifications	107
A Acronyms and Abbreviations.....	111

1 Safety Precautions

General Safety

NOTICE

- Before performing operations, read through this manual and follow all the precautions to prevent accidents. The "DANGER", "WARNING", "CAUTION", and "NOTICE" marks in this document do not represent all the safety instructions. They are only supplements to the safety instructions.
- The personnel responsible for installing, connecting cables for, commissioning, maintaining, and troubleshooting Huawei products should be qualified and trained to master the correct operation methods and the knowledge of safety precautions.

When operating Huawei equipment, in addition to following the general precautions in this document, follow the specific safety instructions given by Huawei. The safety precautions provided in this document do not cover all the safety precautions. Huawei shall not be liable for any consequence caused by the violation of the safety operation regulations and design, production, and usage standards.

Disclaimer

Huawei shall not be liable for any consequence caused by any of the following events:

- Transportation damage
- Violation of the storage requirements specified in this document
- Incorrect storage, installation, or use
- Installation or use by unqualified personnel
- Failure to obey the operation instructions and safety precautions in this document
- Operation in extreme environments which are not covered in this document
- Operation beyond specified ranges
- Unauthorized modifications to the product or software code or removal of the product
- Device damage due to force majeure (such as lightning, earthquake, fire, and storm)
- The warranty expires and the warranty service is not extended.
- Installation or use in environments which are not specified in related international standards

Personnel Requirements

Only certified electricians are allowed to install, connect cables for, commission, maintain, troubleshoot, and replace the SUN2000. Operation personnel must meet the following requirements:

- Receive professional training.
- Read through this document and follow all the precautions.
- Be familiar with the safety specifications about the electrical system.
- Understand the components and functioning of a grid-tied PV system, and be familiar with relevant local standards.
- Wear proper personal protective equipment (PPE) during any operation on the SUN2000.

Protect Labels

- Do not scrawl, damage, or block the labels on the SUN2000 enclosure.
- Do not scrawl, damage, or block the nameplate on the side of the SUN2000 enclosure.

Installation



Never work under power during installation.

-
- Ensure that the SUN2000 is not connected to a power supply or powered on before finishing installation.
 - Ensure that the SUN2000 is installed in a well-ventilated environment.
 - Ensure that the SUN2000 heat sinks are free from blockage.
 - Never open the host panel cover of the SUN2000.
 - Never remove the terminals and cable glands at the bottom of the SUN2000.

Electrical Connections



Before connecting cables to the SUN2000, ensure that the SUN2000 is secured in position and not damaged in any way. Otherwise, electric shocks or fire may occur.

-
- Ensure that all electrical connections comply with local electrical standards.
 - Obtain approval from the local electric utility before using the SUN2000 to generate electricity in grid-tied mode.
 - Ensure that the cables used in a grid-tied PV system are properly connected and insulated and meet all specification requirements.

Operation

 **DANGER**

High voltage may cause an electric shock, which results in serious injury, death or serious property damage from the SUN2000 in operation. Strictly comply with the safety precautions in this document and associated documents to operate the SUN2000.

- Do not touch an energized SUN2000 because the heat sink has a high temperature.
- Follow local laws and regulations when operating the SUN2000.

Maintenance and Replacement

 **DANGER**

High voltage may cause an electric shock, which results in serious injury, death or serious property damage from the SUN2000 in operation. Prior to maintenance, power off the SUN2000 and strictly comply with the safety precautions in this document and associated documents to operate the SUN2000.

- Maintain the SUN2000 with sufficient knowledge of this document, proper tools, and testing equipment.
- Before performing maintenance tasks, power off the SUN2000 and wait at least 15 minutes.
- Temporary warning labels or fences must be placed to prevent unauthorized people entering the site.
- Rectify any faults that may compromise the SUN2000 security performance before powering on the SUN2000 again.
- Observe electrostatic discharge (ESD) precautions during maintenance.

Figure 2-2 Supported power grid

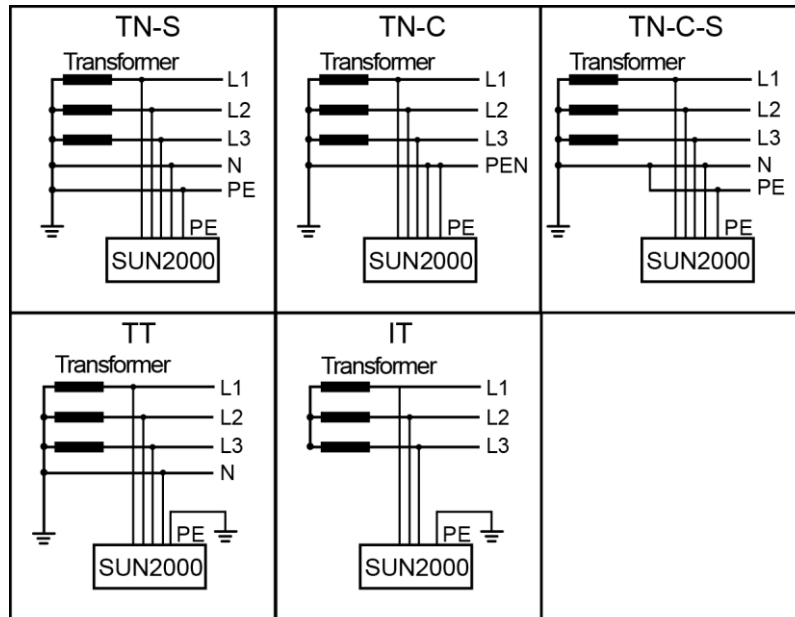

IS01S10001

2.2 Appearance

Dimensions

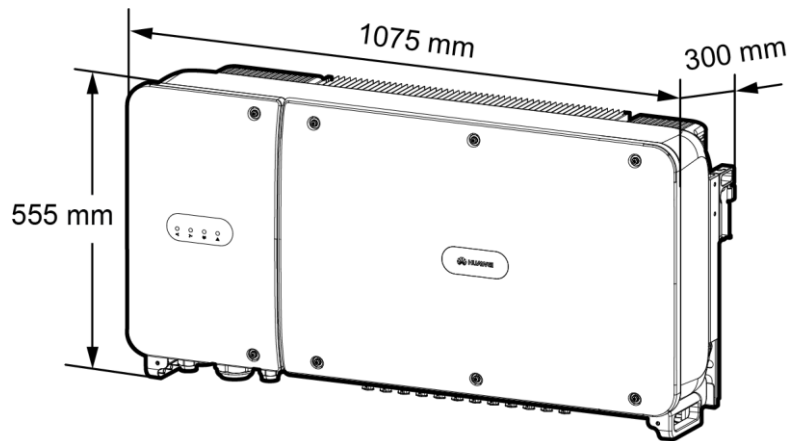

IS06W00005

Front View

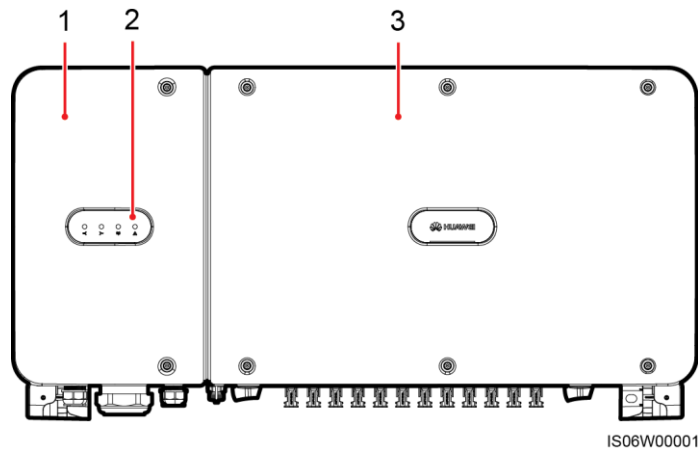





IS06W00001

(1) Maintenance compartment door

(2) LED

(3) Host panel cover

LED	Status	Meaning	
PV connection LED 	Steady green	At least one PV string is properly connected, and the DC input voltage of the corresponding MPPT circuit is higher than or equal to 200 V.	
	Off	The SUN2000 disconnects from all PV strings, or the DC input voltage of each MPPT circuit is less than 200 V.	
Grid-tied LED 	Steady green	The SUN2000 is exporting power to the power grid.	
	Off	The SUN2000 is not exporting power to the power grid.	
Communication LED 	Blinking green (on for 0.2s and then off for 0.2s)	The SUN2000 receives data over RS485 or PLC communication.	
	Off	The SUN2000 has not received data over RS485 or PLC communication for 10 seconds.	
Alarm/Maintenance LED 	Alarm status	Blinking red at long intervals (on for 1s and then off for 4s)	The SUN2000 is generating a warning alarm.
		Blinking red at short intervals (on for 0.5s and then off for 0.5s)	The SUN2000 is generating a minor alarm.
		Steady red	The SUN2000 is generating a major alarm.

	Local maintenance status	Blinking green at long intervals (on for 1s and then off for 1s)	Local maintenance is in progress.
		Blinking green at short intervals (on for 0.125s and then off for 0.125s)	Local maintenance fails.
	Steady green	Local maintenance is successful.	

 **NOTE**

- Local maintenance refers to operations performed after a USB flash drive, Bluetooth module, or USB data cable is inserted into the USB port of the SUN2000. For example, local maintenance includes configuration import and export using a USB flash drive, and maintenance operations on the SUN2000 app installed on a device connected to the SUN2000 by a Bluetooth module or USB data cable.
- If an alarm occurs during local maintenance, the Alarm/Maintenance LED shows the local maintenance status first. After the USB flash drive, Bluetooth module, or USB data cable is removed, the LED shows the alarm status.

Bottom View

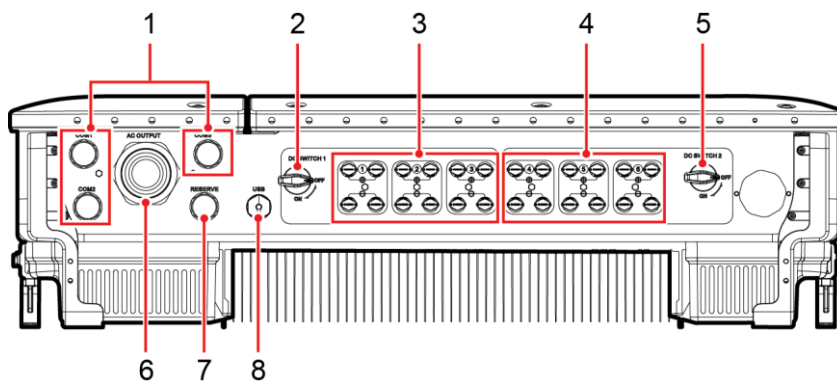

IS06W00002

No.	Component	Silk Screen	Description
1	Cable gland	COM1, COM2, and COM3	Inner diameter: 14–18 mm
2	DC switch 1	DC SWITCH 1	N/A
3	DC input terminals	+/-	Controlled by DC SWITCH 1
4	DC input terminals	+/-	Controlled by DC SWITCH 2
5	DC switch 2	DC SWITCH 2	N/A
6	Cable gland	AC OUTPUT	Inner diameter: 18–44 mm

No.	Component	Silk Screen	Description
7	Cable gland	RESERVE	Inner diameter: 14–18 mm
8	USB port	USB	N/A

Holes Reserved at the Side of the Enclosure

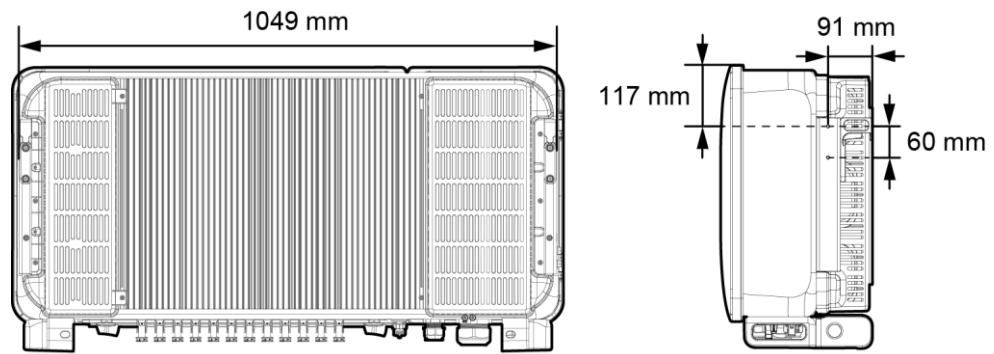

IS06W00022









NOTE

There are two M6 tapped holes reserved on both sides of the enclosures, which are used for installing an awning.

2.3 Label Description

2.3.1 Enclosure Labels

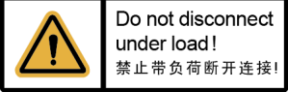
Label	Name	Meaning
	Running warning	Potential hazards exist after the SUN2000 is powered on. Take protective measures when operating the SUN2000.
	Burn warning	Do not touch a running SUN2000 because it generates high temperatures on the shell.

Label	Name	Meaning
	<p>Delay discharge</p>	<ul style="list-style-type: none"> High voltage exists after the SUN2000 is powered on. Only certified electricians are allowed to perform operations on the SUN2000. Residual voltage exists after the SUN2000 is powered off. It takes 15 minutes for the SUN2000 to discharge to the safe voltage.
	<p>Refer to documentation</p>	<p>Reminds operators to refer to the documents provided with the SUN2000.</p>
	<p>Grounding</p>	<p>Indicates the position for connecting the PE cable.</p>
	<p>Operation warning</p>	<p>Do not remove the DC input connector when the SUN2000 is running.</p>
	<p>DC terminal operation warning</p>	<p>High voltage exists after the SUN2000 is powered on. To avoid electric shocks, perform the following system power-off operations before plugging or unplugging DC input connectors of the SUN2000:</p> <ol style="list-style-type: none"> 1. Send a shutdown command. 2. Turn off the downstream AC switch. 3. Turn off the two DC switches at the bottom.
	<p>SUN2000 serial number (SN) label</p>	<p>Indicates the SUN2000 SN.</p>

Label	Name	Meaning
	Weight label	The SUN2000 needs to be carried by four people or using a pallet truck.

2.3.2 Product Nameplate

Figure 2-3 Nameplate of the SUN2000-60KTL-M0

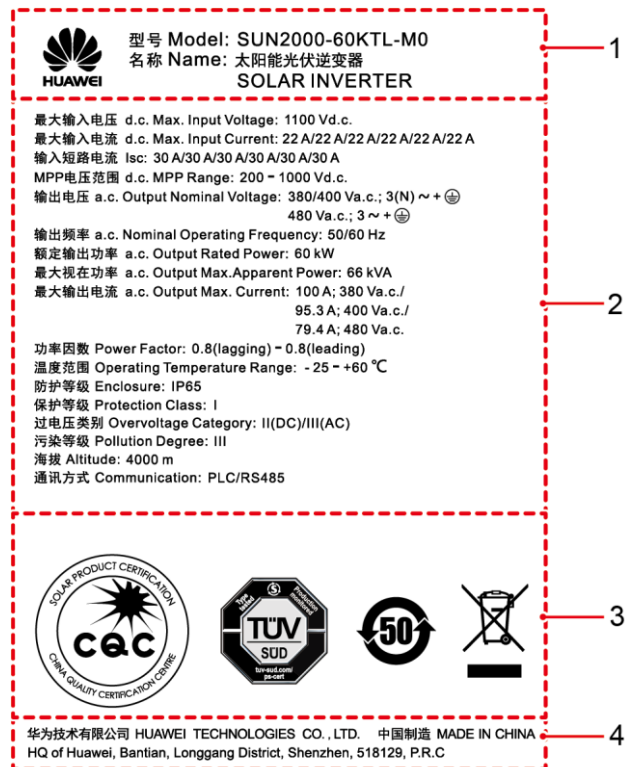

IS06W00024

(1) Trademark, product name, and model number

(2) Important technical specifications





(3) Compliance symbols

(4) Company name and place of production



NOTE

The nameplate figure is for reference only.

Label	Name	Meaning
	CQC certification mark	The SUN2000 has been awarded the NB/T 32004 certification by China Quality Certification Center (CQC).
	TÜV SÜD certification mark	The SUN2000 complies with TÜV SÜD certification standards.
	China Environmentally friendly use period (EFUP)	This product is environmentally friendly for at least 50 years.
	European Union (EU) waste electrical and electronic equipment (WEEE)	This product must not be disposed of as domestic waste.

2.4 Working Principles

2.4.1 Conceptual Diagram

The SUN2000 receives inputs from 12 PV strings. Then the inputs are grouped into six MPPT routes inside the SUN2000 to track the maximum power point of the PV strings. The DC power is then converted into three-phase AC power through an inverter circuit. Surge protection is supported on both the DC and AC sides.

Figure 2-4 SUN2000 conceptual diagram

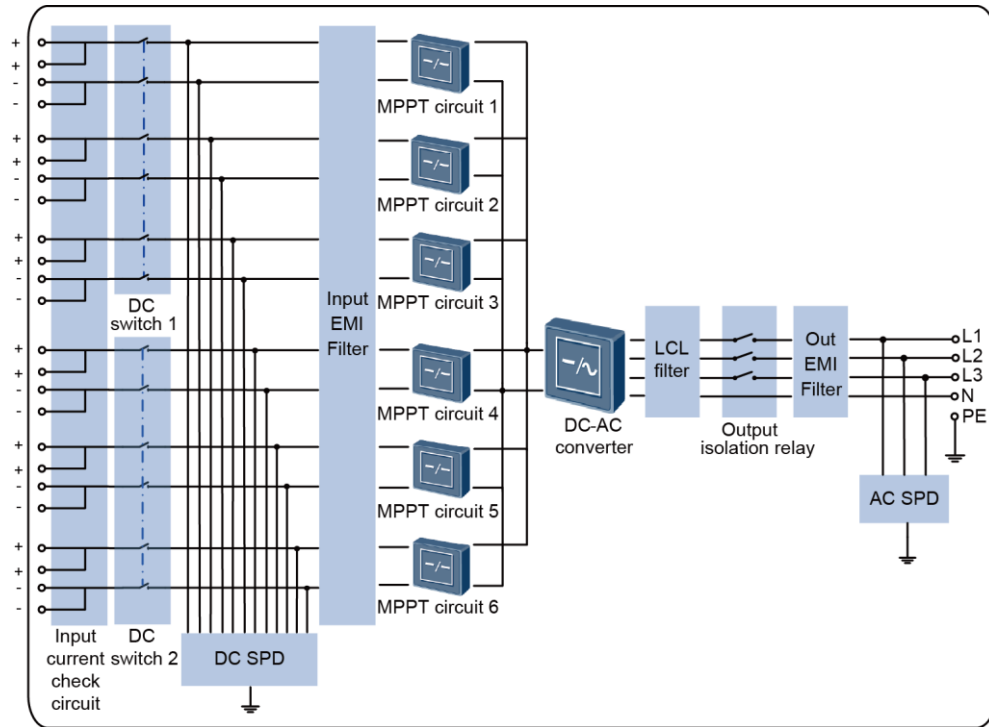

2.4.2 Working Modes

The SUN2000 can work in Standby, Operating, or Shutdown mode.

Figure 2-5 SUN2000 working modes

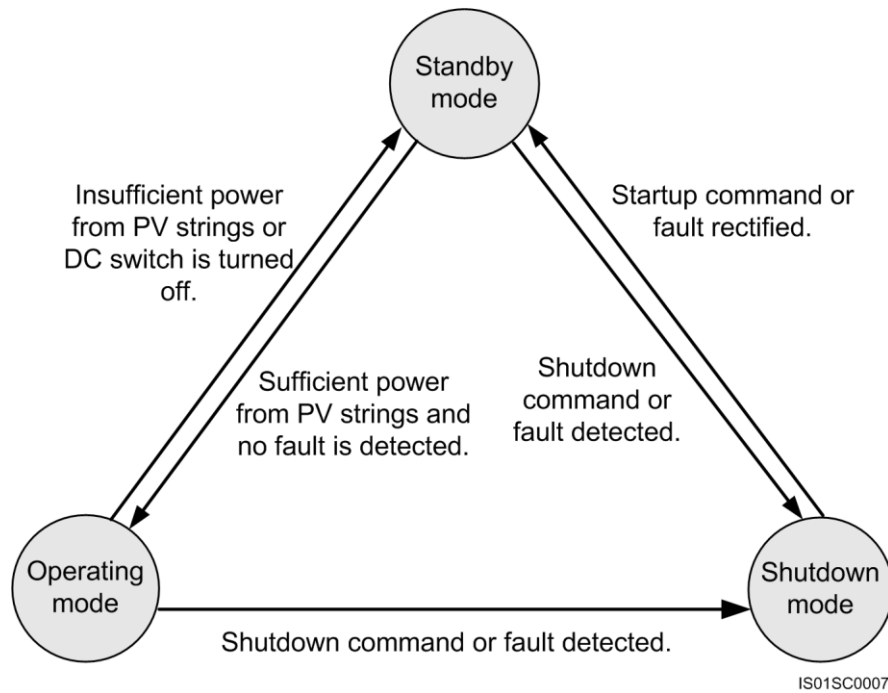

Table 2-1 Working mode description

Working Mode	Description
Standby	<p>The SUN2000 enters Standby mode when the external environment does not meet the requirements for starting the SUN2000. In Standby mode:</p> <ul style="list-style-type: none"> The SUN2000 continuously performs self-check and enters Operating mode once the operating requirements are met. The SUN2000 enters Shutdown mode after detecting a shutdown command or a fault after startup.
Operating	<p>In Operating mode:</p> <ul style="list-style-type: none"> The SUN2000 converts DC power from PV strings into AC power and feeds the power to the power grid. The SUN2000 tracks the maximum power point to maximize the PV string output. The SUN2000 enters Shutdown mode after detecting a fault or a shutdown command, and enters Standby mode after detecting that the PV string output power is not suitable for connecting to the power grid and producing power.
Shutdown	<ul style="list-style-type: none"> In Standby or Operating mode, the SUN2000 enters Shutdown mode after detecting a fault or shutdown command. In Shutdown mode, the SUN2000 enters Standby mode after detecting a startup command or that the fault is rectified.

3 Storage

The following requirements should be met when the SUN2000 needs to be stored prior to installation:

- Put the SUN2000 in the original package. Keep the desiccant and seal it using the adhesive tape.
- Keep the proper storage temperature and humidity.

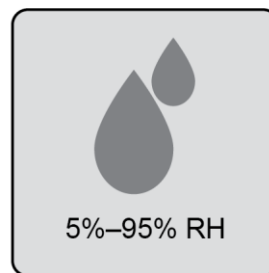
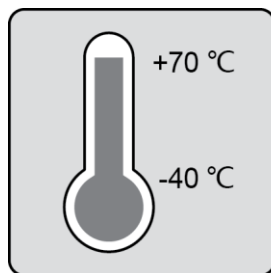

- The SUN2000 should be stored in a clean and dry place and be protected from dust and water vapor corrosion.
- The number of stacked SUN2000s should meet requirements.

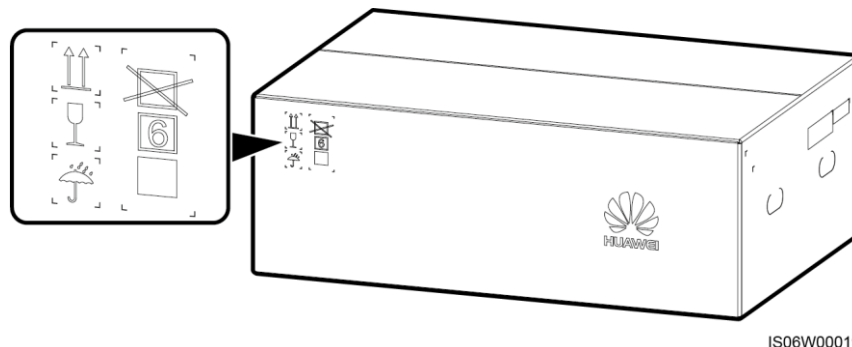

- Regular inspection is required during the storage. Replace the packing materials when necessary.
- After long-term storage, an inspection and test conducted by qualified persons are necessary before the SUN2000 is put into use.

4 Installation

4.1 Checking Before Installation

Outer Packing Materials

Before unpacking the inverter, check the outer packing materials for damage, such as holes and cracks, and check the inverter model. If any damage is found or the inverter model is not what you requested, do not unpack the package and contact your supplier as soon as possible.

Figure 4-1 Position of the inverter model label

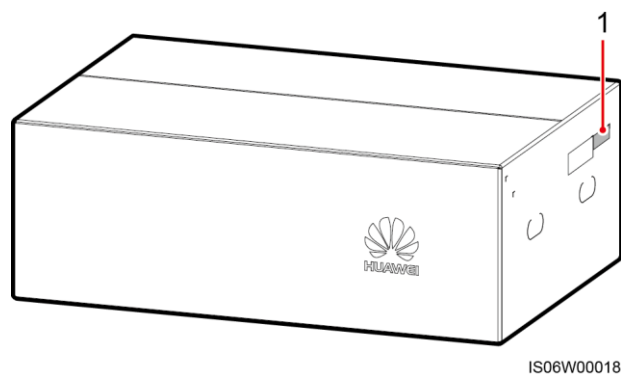

(1) Position of the model label



NOTE

You are advised to remove the packing materials within 24 hours before installing the inverter.

Package Contents









After unpacking the inverter, check that the contents are intact and complete. If any damage is found or any component is missing, contact your supplier.

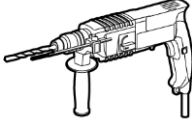
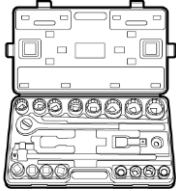
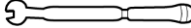
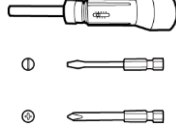
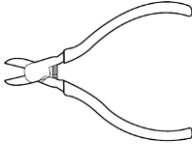
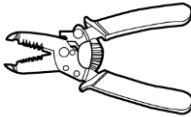

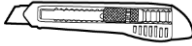

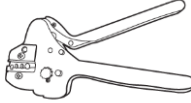
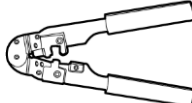
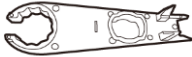



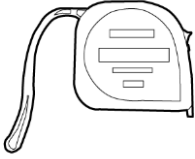

NOTE

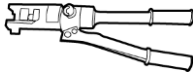
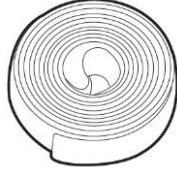
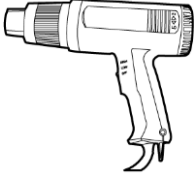
For details about the number of contents, see the *Packing List* in the packing case.

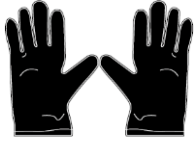
4.2 Tools

Type	Tool			
Installation tool	 Hammer drill Drill bit: $\Phi 14$ mm and $\Phi 16$ mm	 Torque socket wrench	 Torque wrench	 Torque screwdriver (Phillips head: M4; flat head: M4)
	 Diagonal pliers	 Wire stripper	 Flat-head screwdriver Head: 0.6 mm x 3.5 mm	 Rubber mallet
	 Utility knife	 Cable cutter	 Crimping tool Model: H4TC0001 or H4TC0002; manufacturer: Amphenol	 RJ45 crimping tool
	 Removal wrench Model: H4TW0001; manufacturer: AMPHENOL	 Vacuum cleaner	 Multimeter DC voltage measurement range ≥ 1100 V DC	 Marker

Type	Tool			
	 Measuring tape	 Digital or bubble level	 Hydraulic pliers	 Heat shrink tubing
	 Heat gun	 Cable tie	-	-
PPE	 Safety gloves	 Safety goggles	 Anti-dust respirator	 Safety shoes



NOTE

H4TC0001 is used to crimp metal cold forming contacts, while H4TC0002 is used to crimp metal stamping forming contacts.

4.3 Determining the Installation Position

4.3.1 Environment Requirements

Basic Requirements

- The SUN2000 can be installed indoors or outdoors.

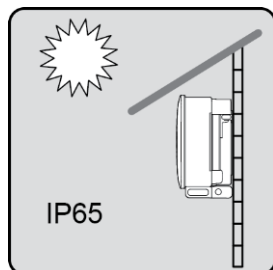

- Do not install the SUN2000 in a place where personnel are easy to come into contact with its enclosure and heat sinks, because these parts are extremely hot during operation.
- Do not install the SUN2000 in areas with flammable or explosive materials.
- Do not install the SUN2000 at a place within children's reach.

- Do not install the SUN2000 outdoors in salt areas because it will be corroded there and may cause fire. A salt area refers to the region within 500 meters from the coast or prone to sea breeze. The regions prone to sea breeze vary depending on weather conditions (such as typhoons and monsoons) or terrains (such as dams and hills).
- The SUN2000 must be installed in a well-ventilated environment to ensure good heat dissipation.
- Recommended: Install the SUN2000 in a sheltered place or a place with an awning.

Mounting Structure Requirements

- The mounting structure where the SUN2000 is installed must be fireproof.
- Do not install the SUN2000 on flammable building materials.
- The SUN2000 is heavy. Ensure that the installation surface is solid enough to bear the weight load.
- In residential areas, do not install the SUN2000 on drywalls or walls made of similar materials which have a weak sound insulation performance because the noise generated by the SUN2000 is noticeable.

4.3.2 Space Requirements

- Reserve enough clearance around the SUN2000 and determine an appropriate installation tilt to ensure sufficient space for installation and heat dissipation.

Figure 4-2 Installation space requirements

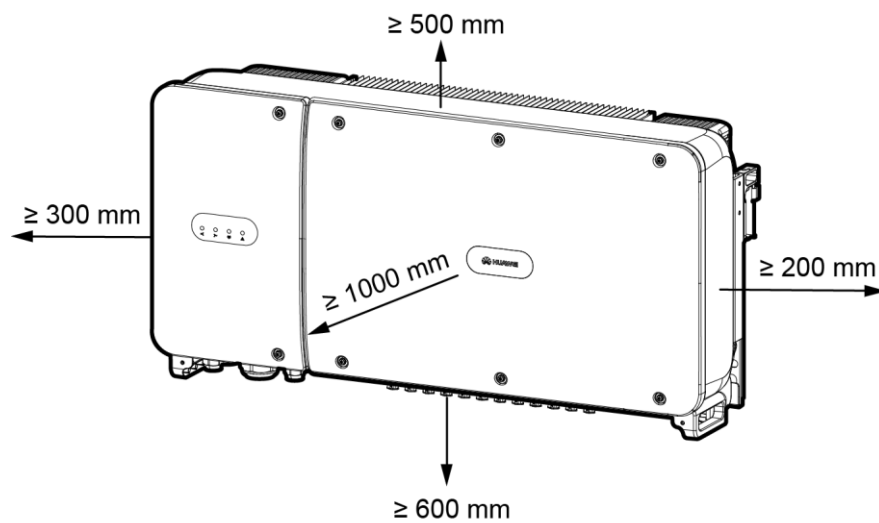

IS06W00004



NOTE

For ease of installing the SUN2000 on the mounting bracket, connecting cables to the bottom of the SUN2000, and maintaining the SUN2000 in future, it is recommended that the bottom clearance be in the range of 600 mm to 730 mm. If you have any questions about the clearances, consult the local technical support engineers.

Figure 4-3 Installation tilts

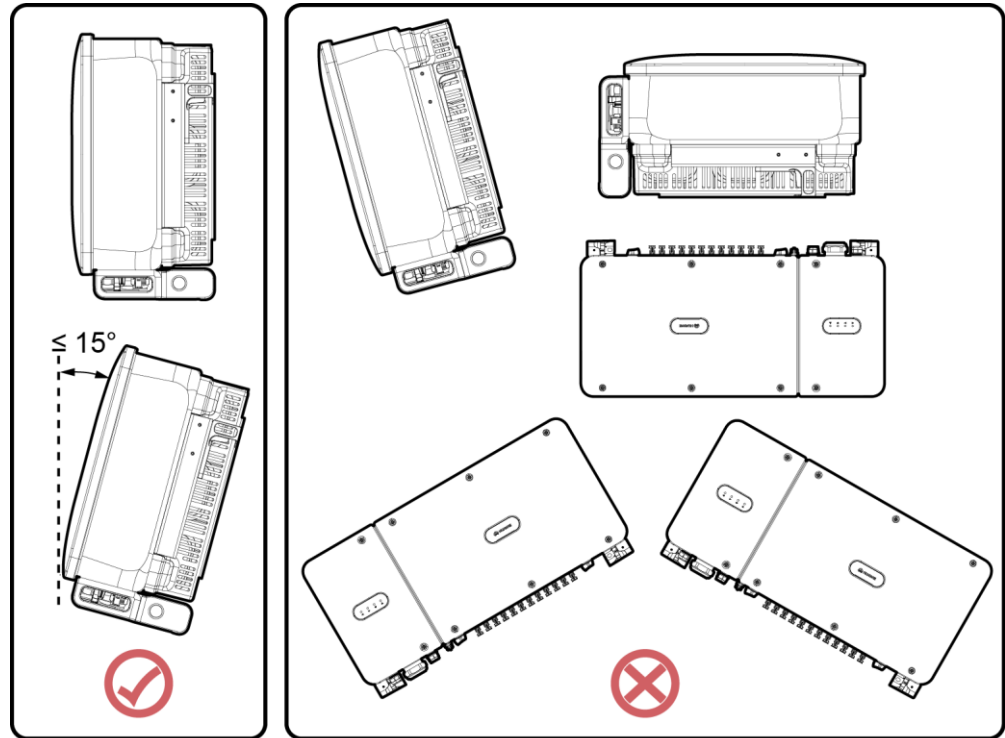

IS06W0007

- When installing multiple SUN2000s, install them in horizontal mode if sufficient space is available and install them in triangle mode if no sufficient space is available. Stacked installation is not recommended.

Figure 4-4 Horizontal installation mode (recommended)

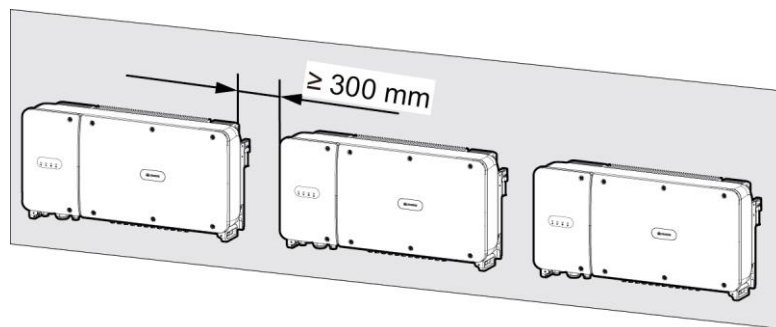

IS06H00009

Figure 4-5 Triangle installation mode (recommended)

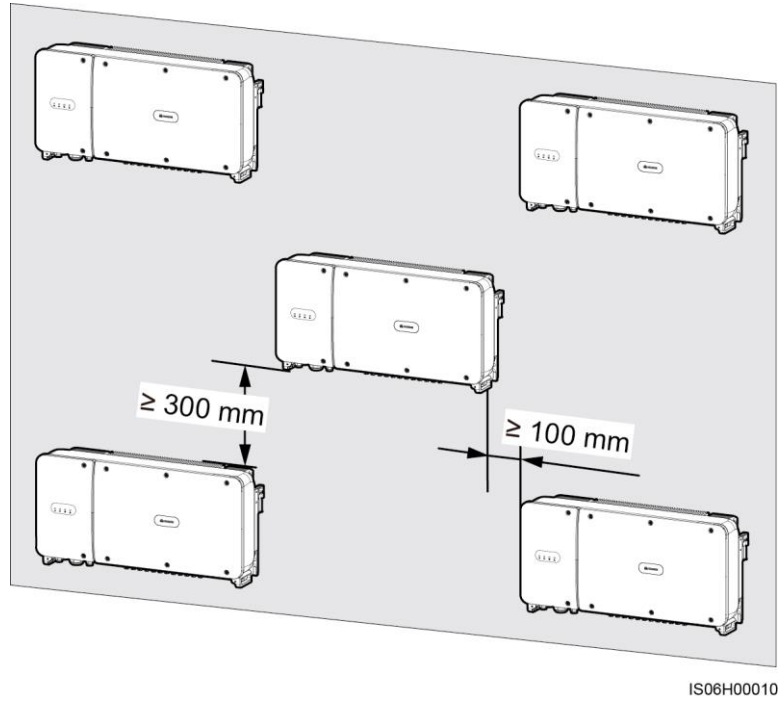
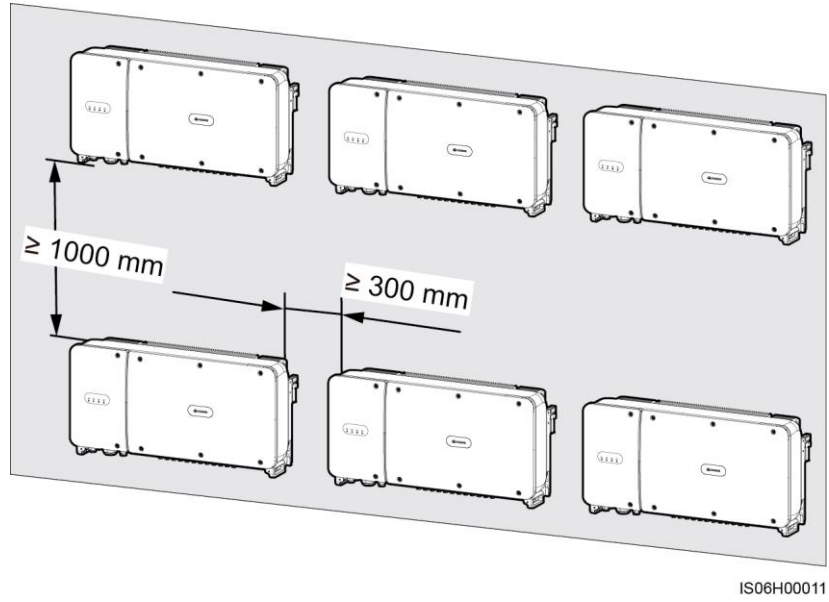

Figure 4-6 Stacked installation mode (not recommended)



4.4 Installing the Mounting Bracket

Installation Precautions

Figure 4-7 shows the SUN2000 mounting bracket dimensions.

Figure 4-7 Mounting bracket dimensions

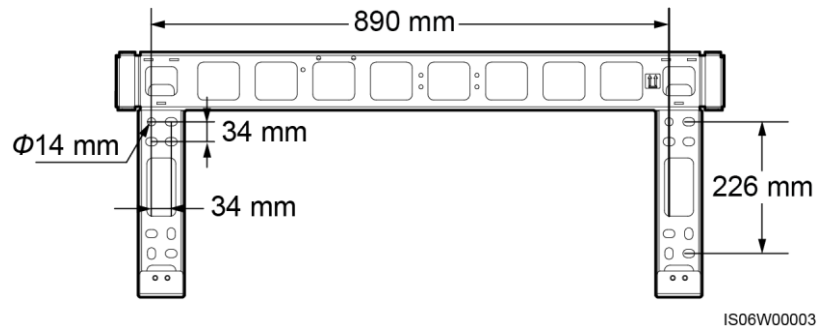

NOTE

The SUN2000 mounting bracket has four groups of tapped holes, each group containing four tapped holes. Mark any hole in each group based on site requirements and mark four holes in total. Two round holes are preferred.

Before installing the mounting bracket, remove the security torx wrench from the mounting bracket and save it for later use.

Figure 4-8 Removing a security torx wrench

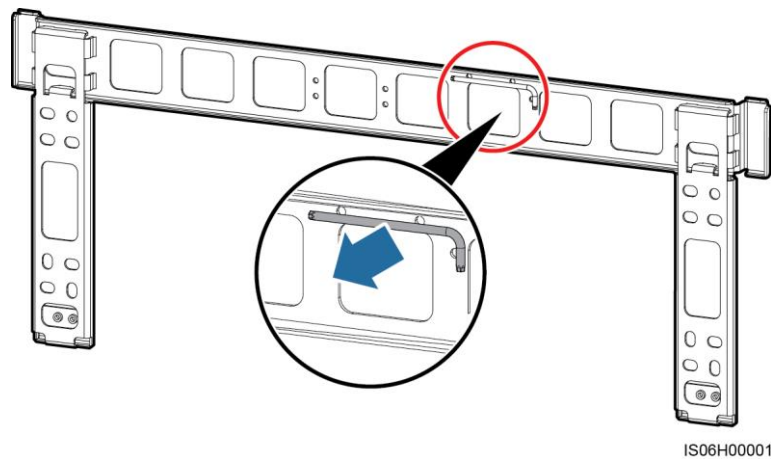

4.4.1 Support-mounted Installation

Support-mounted Installation

Step 1 Determine the positions for drilling holes using the mounting bracket. Level the positions of mounting holes using a bubble or digital level, and mark the positions with a marker.

Figure 4-9 Determining hole positions

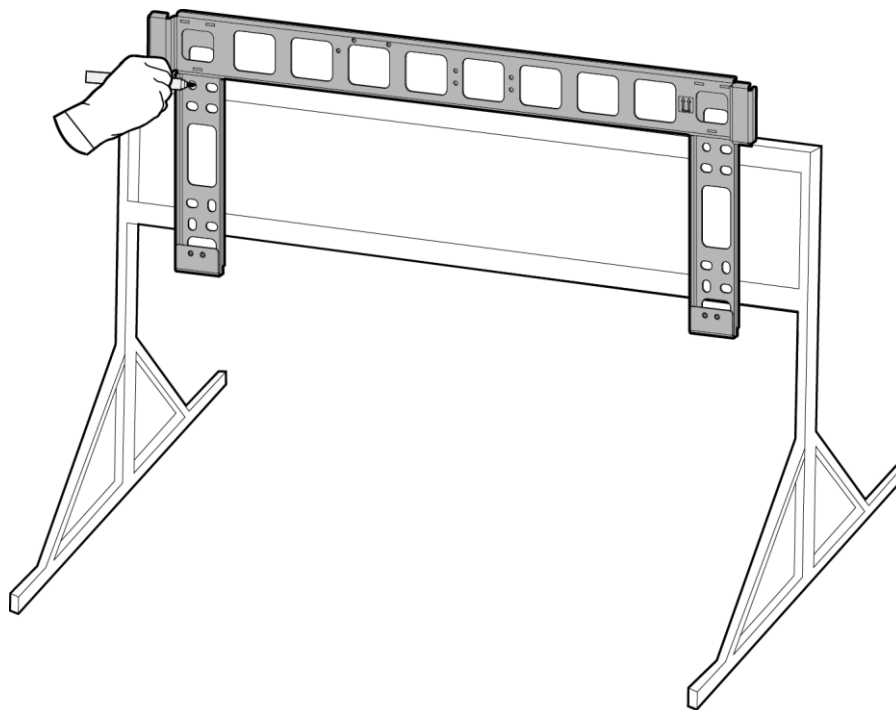

IS06H00004

Step 2 Drill holes using a hammer drill.



NOTE

You are advised to apply anti-rust paint on the hole positions for protection.

Figure 4-10 Drilling a hole

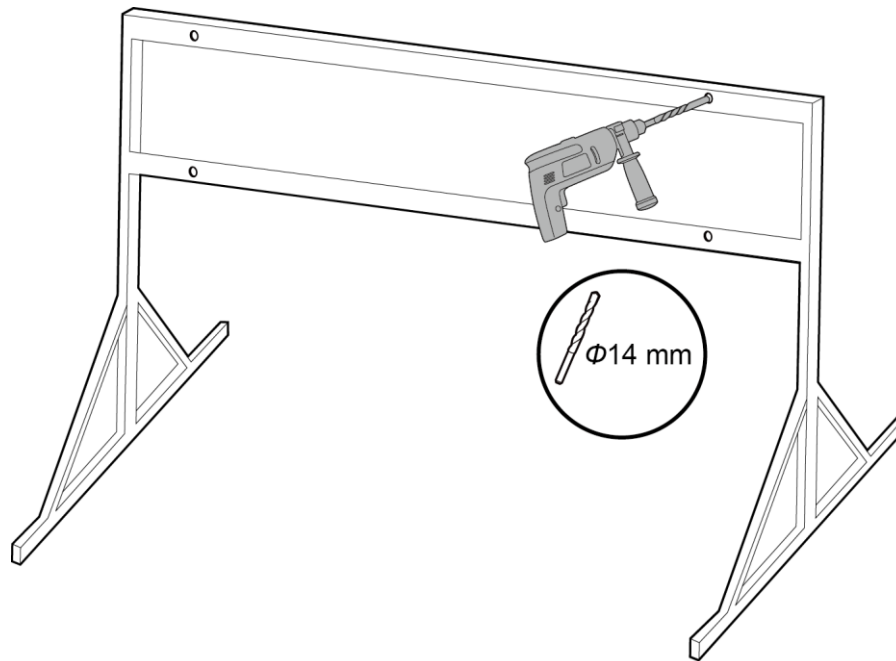

IS06H00005

Step 3 Align the mounting bracket holes with the drilled holes, insert bolt assemblies (flat washers, spring washers, and M12x40 bolts) into the holes through the mounting bracket, and secure them using the supplied stainless steel nuts and flat washers.



NOTE

M12x40 bolt assemblies are provided with the SUN2000. If the bolt length does not meet the installation requirements, prepare M12 bolt assemblies by yourself and use them together with the provided M12 nuts.

Figure 4-11 Securing a mounting bracket

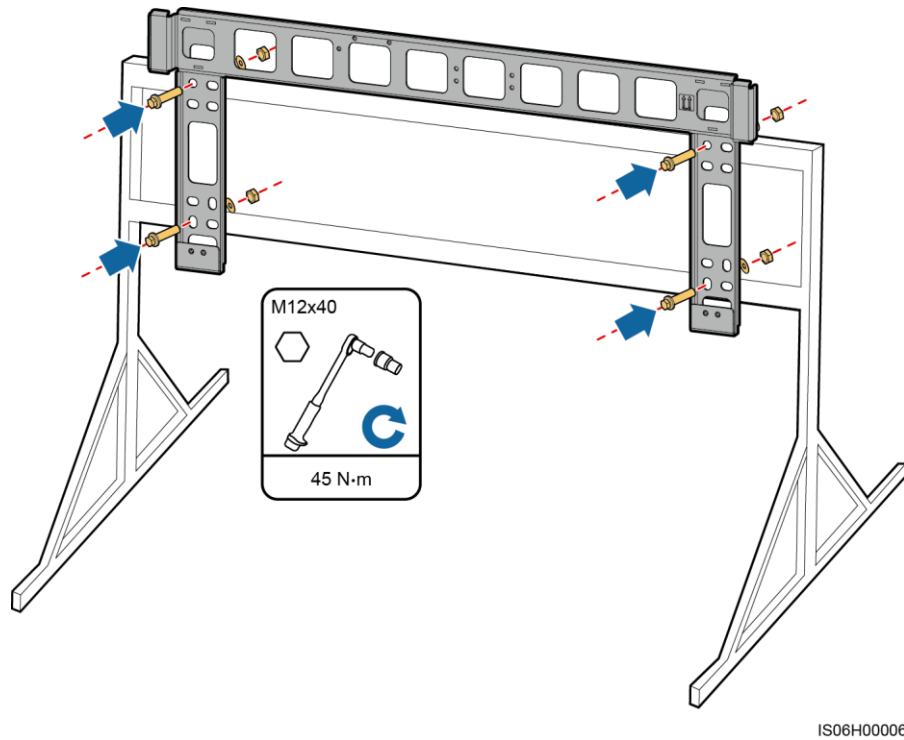

----End

4.4.2 Wall-mounted Installation

Wall-mounted Installation

- Step 1** Determine the positions for drilling holes using the mounting bracket. Level the positions of mounting holes using a bubble or digital level, and mark the positions with a marker.

Figure 4-12 Determining hole positions

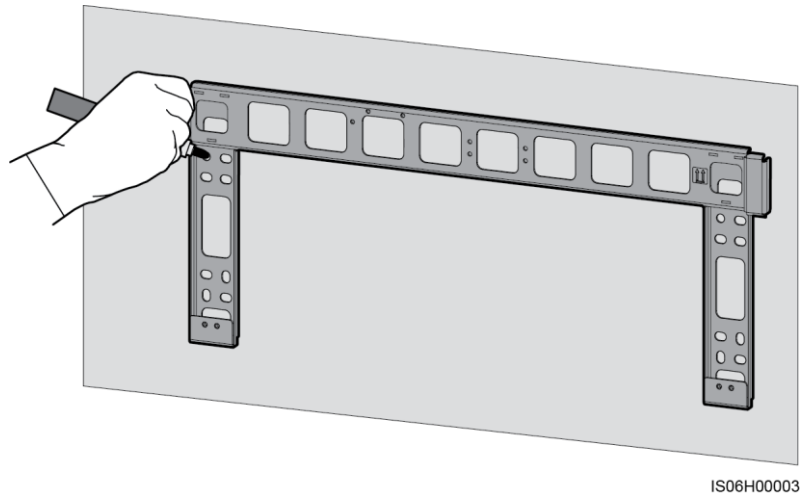

Step 2 Drill holes using a hammer drill and install expansion bolts.

 **NOTE**

You need to prepare expansion bolts. M12x60 stainless steel expansion bolts are recommended.

Figure 4-13 Drilling a hole and installing an expansion bolt

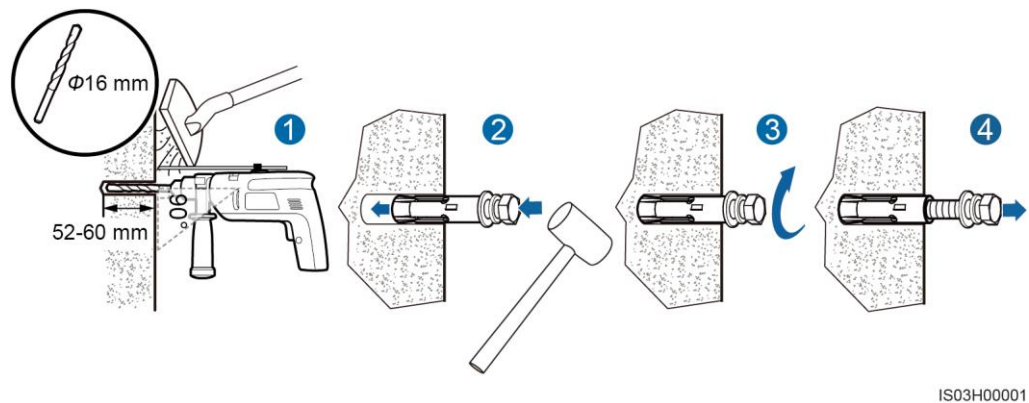

 **WARNING**

Avoid drilling holes in the utility pipes and/or cables attached to back of the wall.

NOTICE

- To prevent dust inhalation or contact with eyes, wear safety goggles and an anti-dust respirator when drilling holes.
- Clean up any dust in and around the holes using a vacuum cleaner and measure the distance between holes. If the holes are inaccurately positioned, drill a new set of holes.
- Level the head of the expansion sleeve with the concrete wall after removing the bolt, spring washer, and flat washer. Otherwise, the mounting bracket will not be securely installed on the concrete wall.

Step 3 Align the mounting bracket holes with the drilled holes, insert expansion bolts into the holes through the mounting bracket, and then tighten the expansion bolts.

Figure 4-14 Securing a mounting bracket

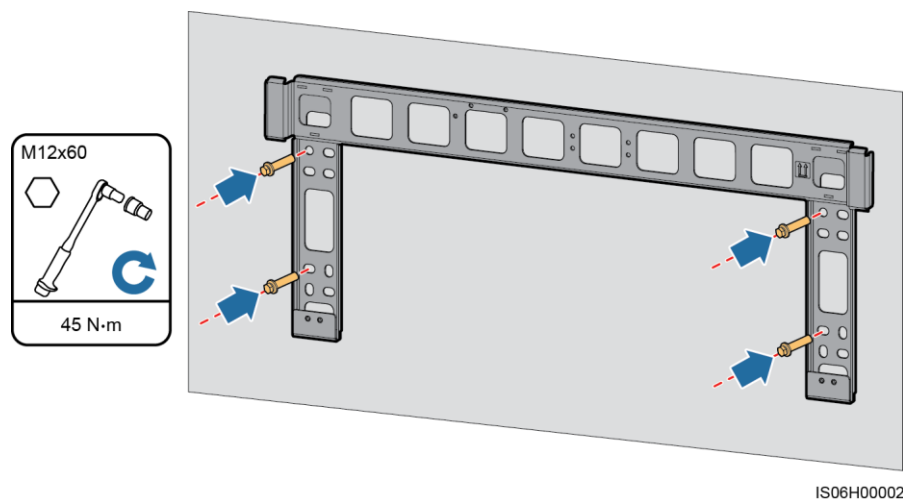

----End

4.5 Installing the SUN2000

Installation Precautions

Before installing the SUN2000, take it out from the packing case and move it to the installation position.

Figure 4-15 Taking out a SUN2000

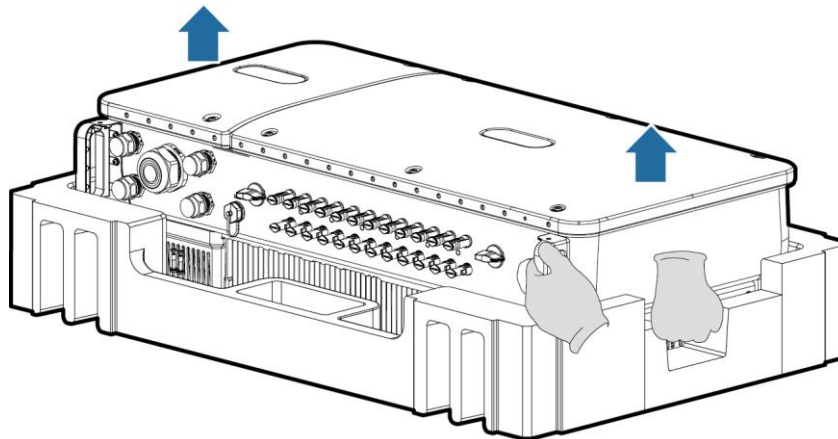

IS06H00041

CAUTION

To prevent device damage and personal injury, keep balance when moving the SUN2000 because it is heavy.

NOTICE

- Move the SUN2000 with the help of other three persons or using an appropriate transportation tool.
 - Do not use the ports and wiring terminals at the bottom to support any weight of the SUN2000.
 - When you need to temporarily place the SUN2000 on the ground, use foam, paper, or other protection material to prevent damage to its enclosure.
-

Procedure

- Step 1** If you can mount the SUN2000 onto the mounting bracket directly, go to [Step 3](#) and then [Step 5](#).
- Step 2** If you cannot mount the SUN2000 onto the mounting bracket directly, go to [Step 3](#) and then [Step 6](#).
- Step 3** Lift the SUN2000 and turn it upright.

CAUTION

To prevent device damage and personal injury, keep balance when raising the SUN2000 because it is heavy.

- Step 4** Run a lifting sling through the lifting eyes of the SUN2000.

CAUTION

When lifting the SUN2000, keep balance to prevent the SUN2000 impacting with a wall or other objects.

Figure 4-16 Lifting a SUN2000

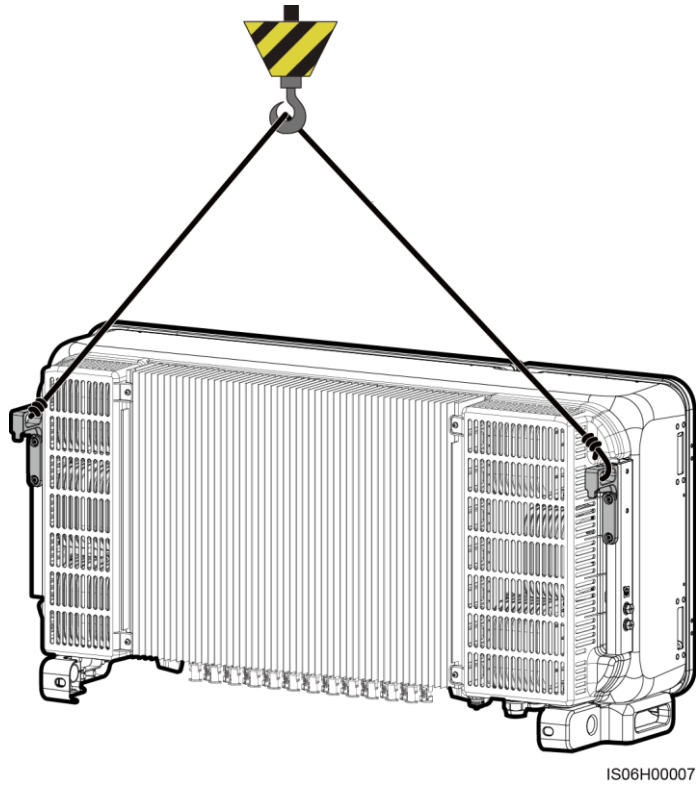

NOTE

The figure is for reference only.

Step 5 Install the SUN2000 on the mounting bracket.

Figure 4-17 Mounting the SUN2000 onto a mounting bracket

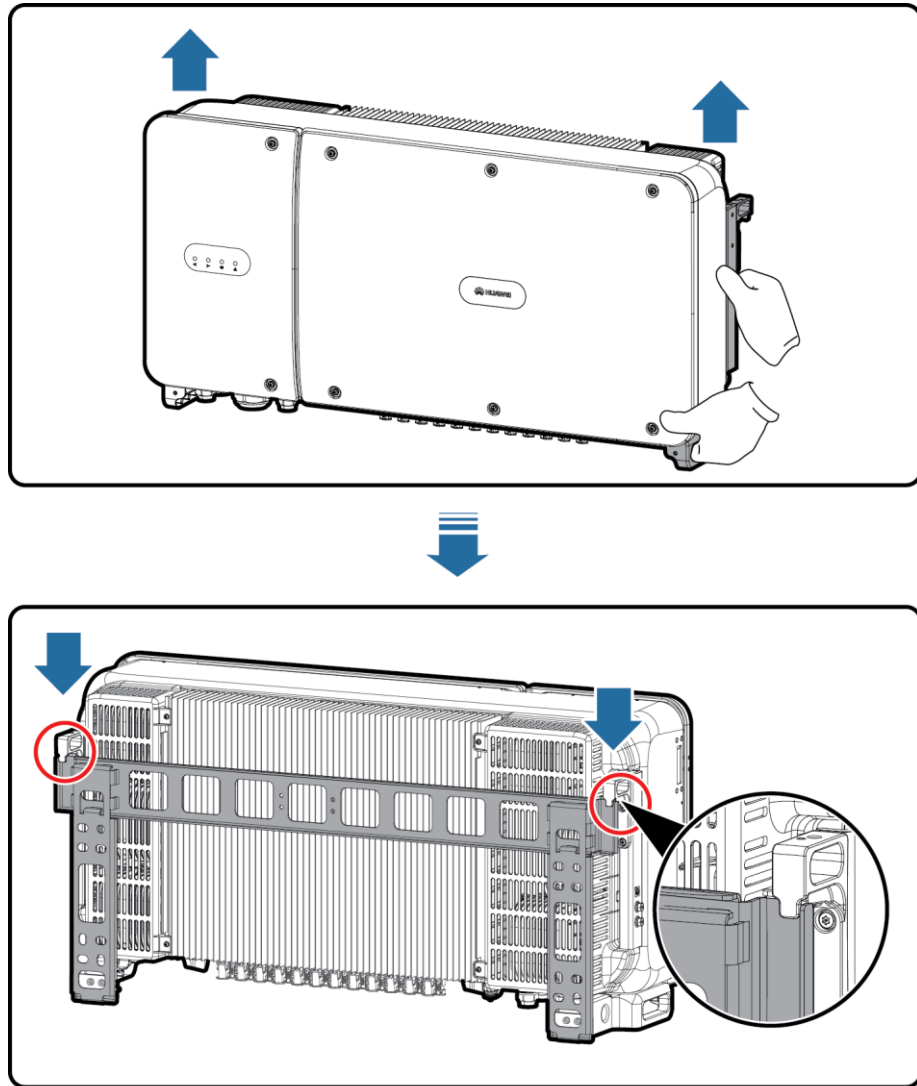

IS06H00008

Step 6 Tighten the two antitheft screws using a security torx wrench.

Figure 4-18 Tightening antitheft screws

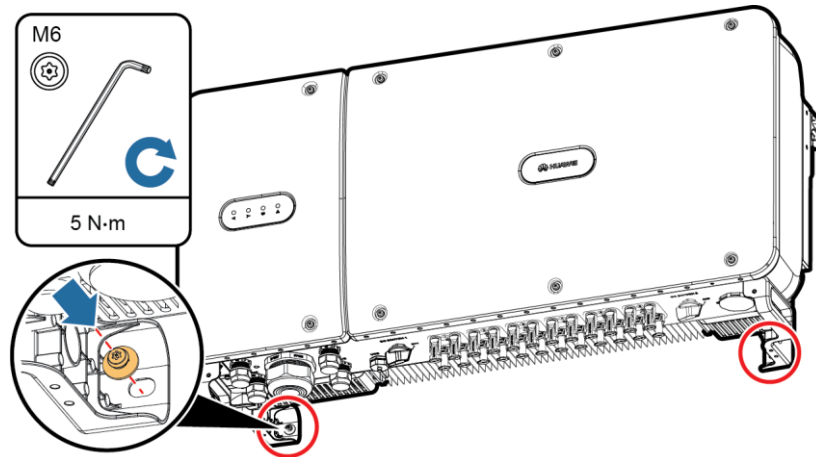

IS06H00012

----End

5 Electrical Connections

5.1 Precautions

DANGER

Before connecting cables, ensure that the two DC switches on the SUN2000 are OFF. Otherwise, the high voltage of the SUN2000 may result in electric shocks.

WARNING

- The equipment damage caused by incorrect cable connections is beyond the warranty scope.
- Only certified electrician can perform electrical terminations.
- Wear proper PPE at all time when terminating cables.
- To prevent poor cable contact due to overstress caused by ground subsidence, it is recommended that the cable be bent and reserved and then connected to the appropriate port.

NOTE

The cable colors shown in the electrical connection diagrams provided in this chapter are for reference only. Select cables in accordance with local cable specifications (green-and-yellow cables are only used for grounding).

5.2 Crimping the OT Terminal

Requirements for the OT Terminal

- If a copper cable is used, use a copper wiring terminal.
- If a copper-clad aluminum cable is used, use a copper wiring terminal.
- If an aluminum alloy cable is used, use a copper to aluminum adapter terminal or an aluminum wiring terminal with a copper to aluminum adapter washer.

NOTICE

- Directly connecting an aluminum wiring terminal to the AC terminal block will cause electro-chemical corrosion and weaken the cable connection reliability.
- The copper to aluminum adapter terminal or an aluminum wiring terminal with a copper to aluminum adapter washer must comply with IEC61238-1.
- Do not mix up the aluminum and copper sides of the copper to aluminum adapter washer. Ensure that the aluminum side of the washer contacts the aluminum wiring terminal, and the copper side contacts the AC terminal block.

Figure 5-1 Requirements for the OT terminal

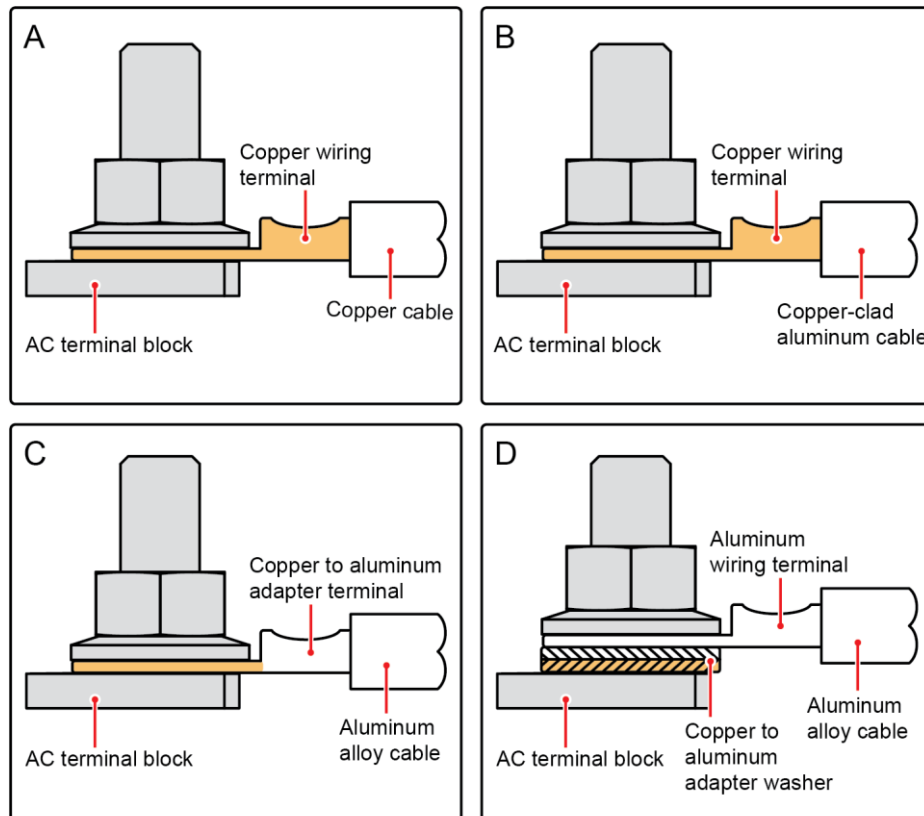

IS03H00062

Crimping the OT terminal

NOTICE

- Pay attention not to damage the core wire when stripping a cable.
- The cavity formed after the conductor crimp strip of the OT terminal is crimped must wrap the core wires completely. The core wires must contact the OT terminal closely.
- Wrap the wire crimping area with heat shrink tubing or PVC insulation tape. The following figure uses heat shrink tubing as an example.
- When using the heat gun, protect devices from being scorched.

Figure 5-2 Crimping the OT Terminal

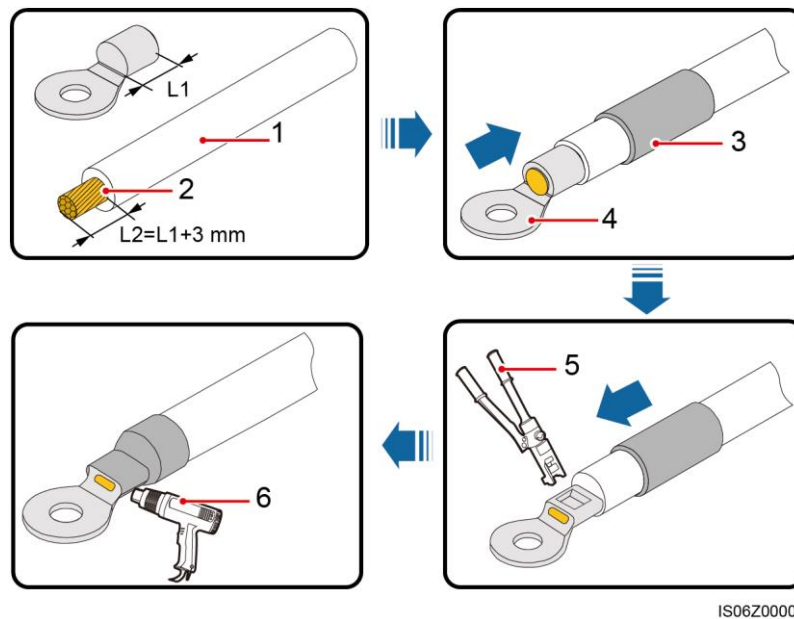

- | | | |
|-----------------|----------------------|------------------------|
| (1) Cable | (2) Core wire | (3) Heat shrink tubing |
| (4) OT terminal | (5) Hydraulic pliers | (6) Heat gun |

5.3 Opening the Maintenance Compartment Door

Precautions

CAUTION

- Never open the host panel cover of the SUN2000.
- Before opening the maintenance compartment door, ensure that neither of the AC and DC connections to the SUN2000 is connected.
- If you need to open the maintenance compartment door on rainy or snowy days, take protective measures to prevent rain and snow entering the maintenance compartment. If it is impossible to take protective measures, do not open the maintenance compartment door on rainy or snowy days.
- Do not leave extra hardware in the maintenance compartment.

Procedure

Step 1 Partially loosen the two screws on the maintenance compartment door.

Figure 5-3 Loosening screws

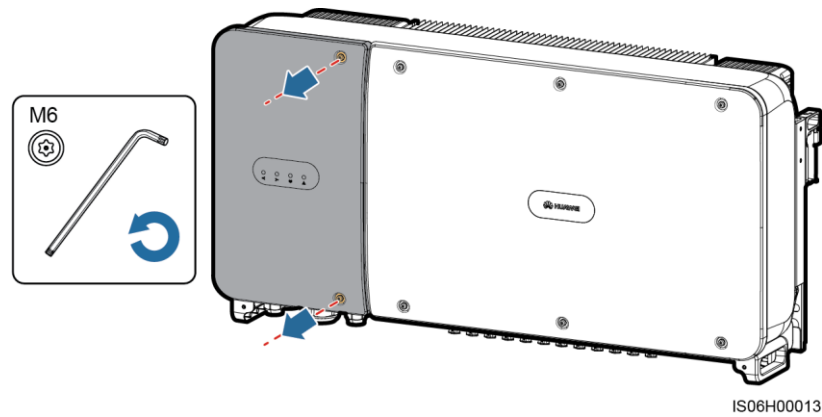

NOTE

If the screws on the enclosure door are lost, obtain spare screws from the fitting bag bound to the inductor cover at the bottom of the enclosure.

Figure 5-4 Position for spare screws

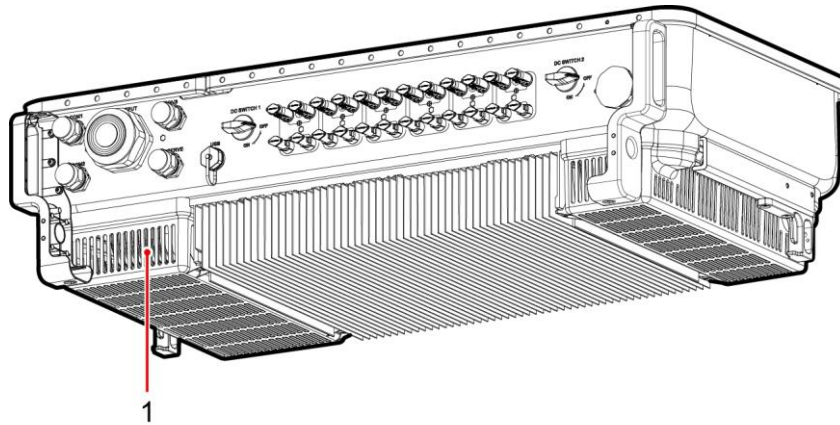

IS06H00047

(1) Position for spare screws

Step 2 Open the maintenance compartment door and keep it open with the support bar.

Figure 5-5 Keeping the door open with a support bar

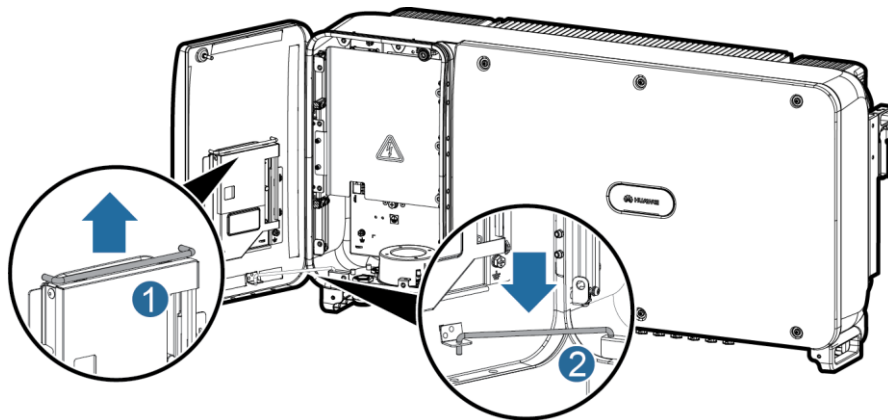

IS06H00062

Step 3 Remove the cover and hang it on the hook of the door.

Figure 5-6 Removing a cover

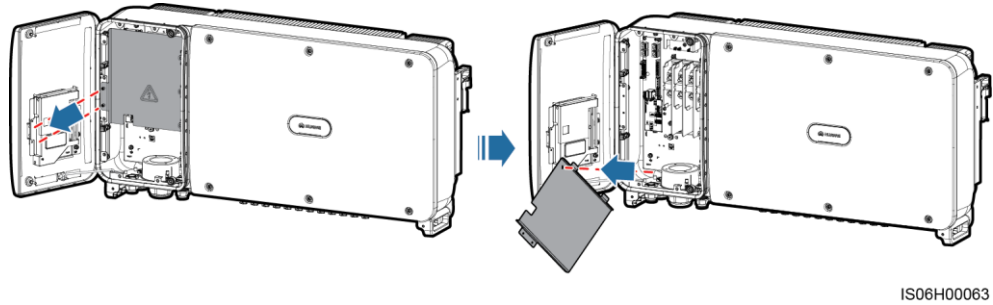

IS06H00063

----End

5.4 Installing the AC Output Power Cable

Precautions

A three-phase AC switch needs to be configured outside the AC side of the SUN2000. To ensure that the SUN2000 can safely disconnect from the power grid under abnormal conditions, select an appropriate overcurrent protection device according to local power distribution regulations.

Model	Recommended Overcurrent Protective Device Specifications
SUN2000-50KTL-M0	125 A
SUN2000-60KTL-M0	125 A

WARNING

Do not connect loads between the SUN2000 and the AC switch.

The SUN2000 is integrated with a comprehensive residual current monitoring unit (RCMU) to distinguish fault current from residual current. Upon detecting that the residual current exceeds the threshold, the SUN2000 immediately disconnects from the power grid.

NOTE

- If an AC switch that can detect residual current is installed outside the SUN2000-50KTL-M0, the residual current value to trigger the switch should be greater than 550 mA.
- If an AC switch that can detect residual current is installed outside the SUN2000-60KTL-M0, the residual current value to trigger the switch should be greater than 660 mA.

Wiring Precautions

NOTICE

Ensure that the SUN2000 PE cable is securely connected. Otherwise the repair of the built-in PID would be affected.

- The ground point on the enclosure is preferred to connect to the PE cable for the SUN2000.
- The ground point in the maintenance compartment is mainly used for connecting to the ground cable included in the multi-core AC power cable.
- There are two ground points on the enclosure and you only need either of them.
- It is recommended that the ground cable be connected to a nearby ground point. For a system with multiple SUN2000s connected in parallel, connect the ground points of all SUN2000s to ensure equipotential connections to ground cables.

Cable Specifications

- If you connect a ground cable to the ground point on the chassis shell in a scenario without a neutral wire, you are advised to use a three-core (L1, L2, and L3) outdoor cable.
- If you connect a ground cable to the ground point in the maintenance compartment in a scenario without a neutral wire, you are advised to use a four-core (L1, L2, L3, and PE) outdoor cable.
- If you connect a ground cable to the ground point on the chassis shell in a scenario with a neutral wire, you are advised to use a four-core (L1, L2, L3, and N) outdoor cable.
- If you connect a ground cable to the ground point in the maintenance compartment in a scenario with a neutral wire, you are advised to use a five-core (L1, L2, L3, N, and PE) outdoor cable.
- You need to prepare OT-M8 terminals that match the cables.

Table 5-1 AC Power Cable Specifications

Cable Specifications		Copper-Core Cable	Copper-Clad Aluminum Cable or Aluminum Alloy Cable
Conductor cross-sectional area (mm ²)	Range	35–70	50–70
	Recommended value	35	50

Table 5-2 Ground cable specifications

Cross-Sectional Area S (mm ²) of the AC Power Cable Conductor	Cross-Sectional Area S _P (mm ²) of the PE Cable Conductor
16 < S ≤ 35	S _P ≥ 16
35 < S	S _P ≥ S/2

Cross-Sectional Area S (mm^2) of the AC Power Cable Conductor	Cross-Sectional Area S_P (mm^2) of the PE Cable Conductor
The values in this table are valid only if the PE cable and AC power cable use the same conductor material. If this is not so, the cross-sectional area of the PE cable conductor is to be determined in a manner which produces a conductance equivalent to that which results from the application of this table.	

Installing the PE Cable

- Step 1** Crimp an OT terminal.
- Step 2** Secure the PE cable using the ground screw.

Figure 5-7 Connecting a PE cable

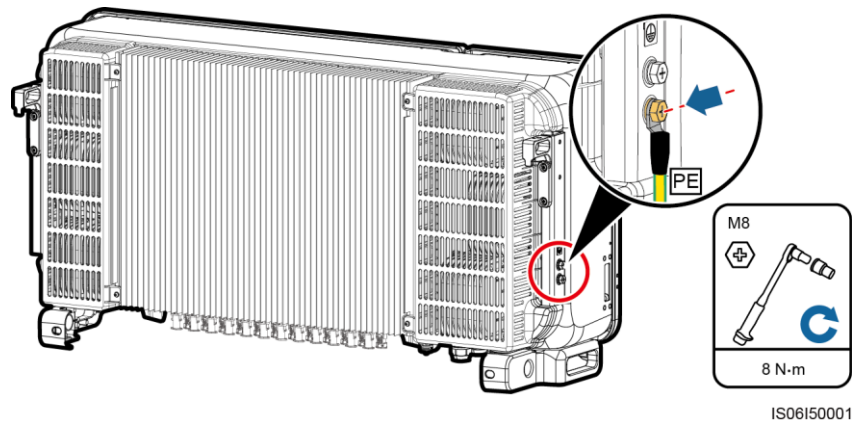

- Step 3** (Optional) To enhance the corrosion resistance of a ground terminal, apply silica gel or paint around the terminal.

----End

Installing the AC Output Power Cable

- Step 1** Remove the locking cap from the AC OUTPUT cable gland and then remove the plug.
- Step 2** Route the cable through the cable gland.

NOTICE

1. Select appropriate rubber fittings based on the outer diameter of the AC power cable to ensure proper sealing.
2. To avoid damaging the rubber fitting, do not route a cable with a crimped OT terminal directly through the rubber fitting.
3. Adjusting a cable when the thread-lock sealing nut is tightened will shift the rubber fitting, which will affect the Ingress Protection Rating of the device.

Figure 5-8 Routing a cable

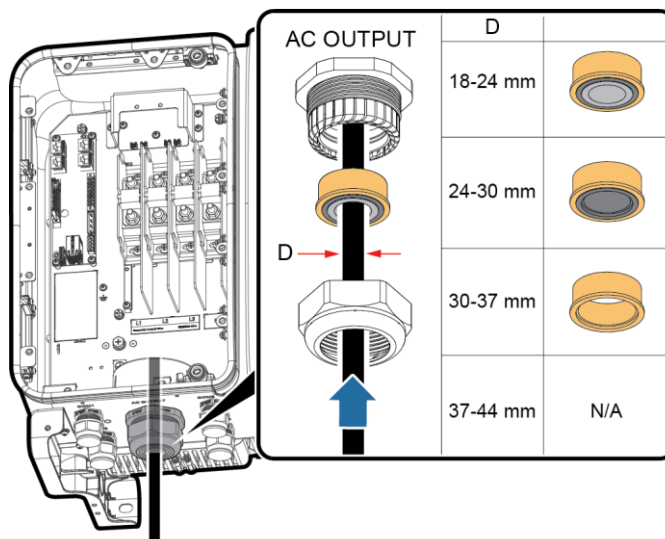

IS06H00068

- Step 3** Remove an appropriate length of the jacket and insulation layer from the AC output power cable using a wire stripper.

NOTICE

Ensure that the jacket is in the maintenance compartment.

Figure 5-9 Three-core cable (excluding the ground cable or neutral wire)

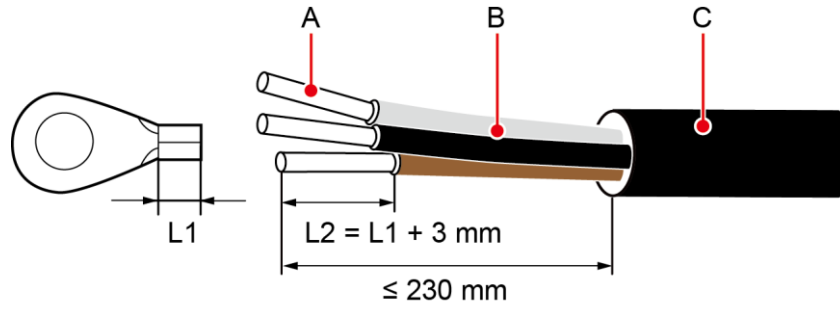

IS06H00035

(A) Core wire

(B) Insulation layer

(C) Jacket

Figure 5-10 Four-core cable (including the ground cable but excluding the neutral wire)

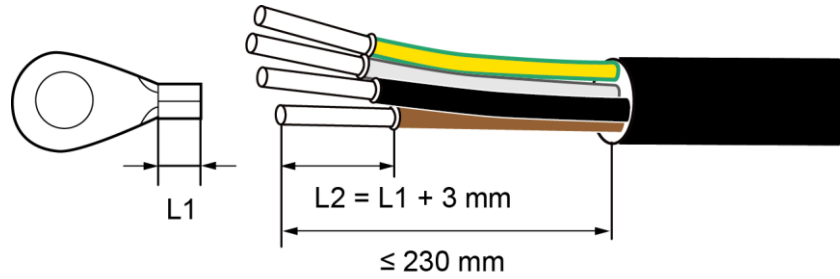

IS06H00036

Figure 5-11 Four-core cable (excluding the ground cable but including the neutral wire)

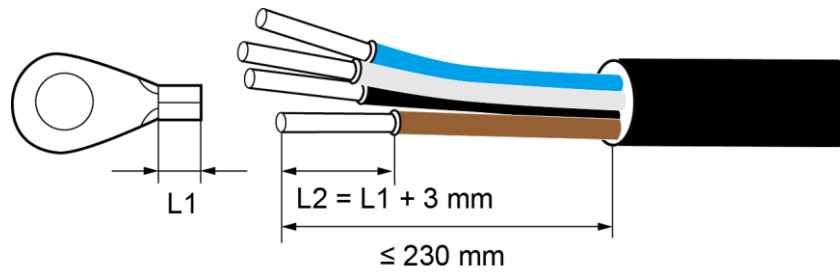

IS06H00075

Figure 5-12 Five-core cable (including the ground cable and neutral wire)

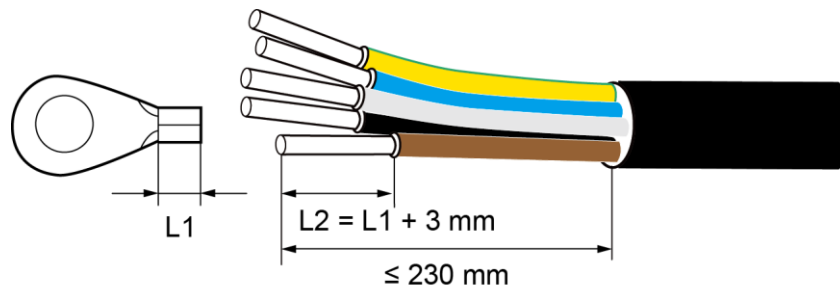

IS06H00074

Step 4 Crimp an OT terminal.

Step 5 Land the AC output power cable in the terminal block, and tighten the nuts with a torque wrench that has an extension rod.

NOTICE

- Ensure that AC terminations provide firm and solid electrical connections. Failing to do so may cause SUN2000 malfunction and damage to its terminal block, even starting thermal events.
- If the AC output power cables are subject to a pulling force because the inverter is not installed stably, ensure that the last cable that bears the stress is the PE cable.

Figure 5-13 Three-core cable (excluding the ground cable or neutral wire)

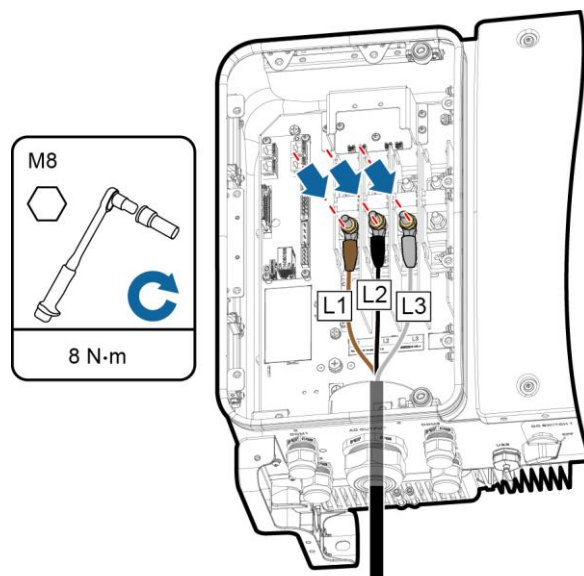

IS06I20010

Figure 5-14 Four-core cable (including the ground cable but excluding the neutral wire)

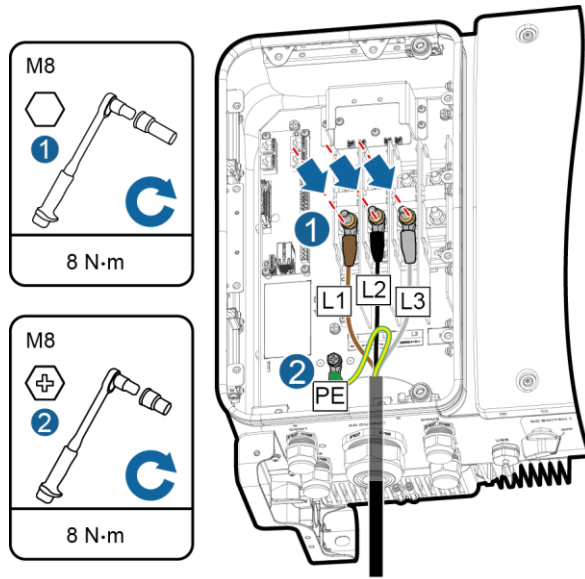

IS06I20011

Figure 5-15 Four-core cable (excluding the ground cable but including the neutral wire)

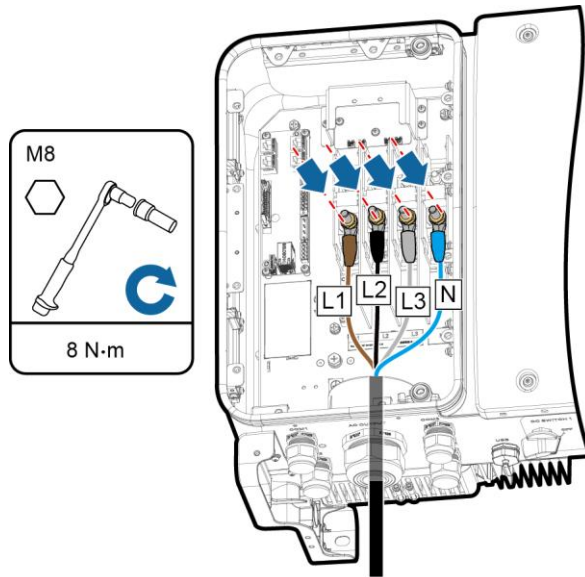

IS06I20008

Figure 5-16 Five-core cable (including the ground cable and neutral wire)

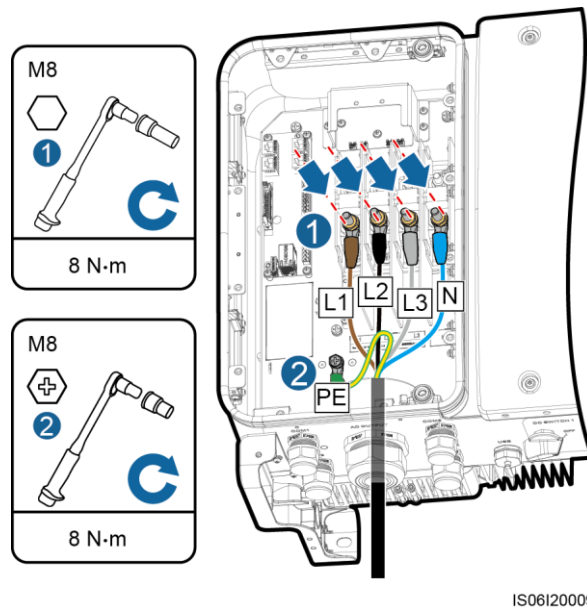

IS06I20009



NOTE

The cable colors shown in figures are for reference only. Select an appropriate cable according to the local standards.

Step 6 Tighten the thread-lock sealing nut.

Step 7 Clear debris from the maintenance compartment.

CAUTION

Ensure that there are no cable residues, scraps, or conductive dusts in the maintenance compartment.

----End

5.5 Connecting DC Input Power Cables

Precautions

⚠ DANGER

- Before connecting the DC input power cable, ensure that the DC voltage is within the safe range (lower than 60 V DC) and that the two DC switches on the SUN2000 are OFF. Failing to do so may result in electric shocks.
- When the SUN2000 is grid-tied, it is not allowed to work on DC circuit, such as connecting or disconnecting a PV string or a PV module in a PV string. Failing to do so may cause electric shocks or arcing (which may further cause fire).

⚠ WARNING

Ensure that the following conditions are met. Otherwise, the SUN2000 will be damaged, or even become a fire hazard.

- The open-circuit voltage of each PV string is always lower than or equal to 1100 V DC.
- The positive and negative terminals of a PV string are connected to corresponding positive and negative DC input terminals of the SUN2000.

NOTICE

- Ensure that the PV module output is well insulated to ground.
- The PV strings connecting to the same MPPT circuit should contain the same number of identical PV modules.
- During the installation of PV strings and SUN2000, the positive or negative terminals of PV strings may be short-circuited to ground if power cables are not properly installed or routed. In this case, an AC or DC short circuit may occur and damage the SUN2000. The caused equipment damage is beyond the warranty scope.

Terminal Description

The SUN2000 provides 12 DC input terminals, among which terminals 1 to 6 are controlled by DC switch 1 and terminals 7 to 12 are controlled by DC switch 2.

Figure 5-17 DC terminals

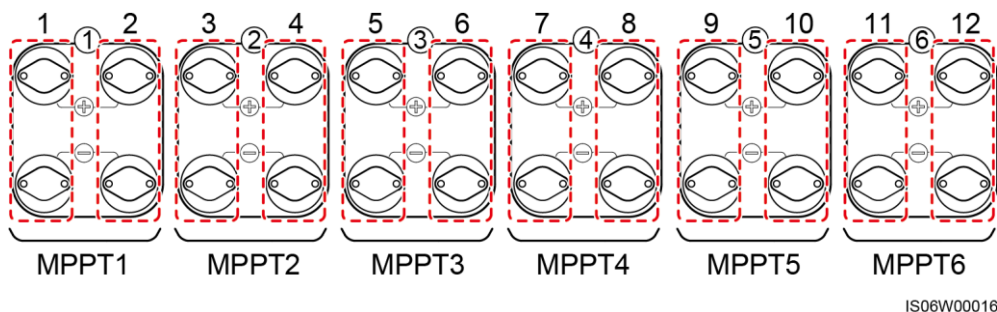

Select DC input terminals according to the following rules:

1. Evenly distribute DC input power cables on the DC input terminals controlled by the two DC switches.
2. Maximize the number of connected MPPT circuits.

Cable Specifications

Cable Type	Conductor Cross-Sectional Area (mm ²)	Cable Outer Diameter (mm)
PV cable that meets the 1100 V standard	4.0–6.0 (12–10 AWG)	4.5–7.8

NOTICE

Cables with high rigidity, such as armored cables, are not recommended, because poor contact may be caused by the bending of the cables.

Procedure

- Step 1** Prepare positive and negative connectors.

CAUTION

Use the Amphenol Helios H4 PV connectors supplied with the SUN2000. If the PV connectors are lost or damaged, purchase the connectors of the same model. The device damage caused by incompatible PV connectors is not covered under any warranty.

NOTICE

- The metal contacts supplied with the DC connectors are either cold forming contacts or stamping forming contacts. Choose the crimping tools that fit the metal contact types. Do not mix up the tools.
- Crimp the metal cold forming contacts using crimping tool H4TC0001 (Amphenol).
- Crimp the metal stamping forming contacts using crimping tool H4TC0002 (Amphenol, recommended), PV-CZM-22100 (Staubli), or PV-CZM-19100 (Staubli). When choosing PV-CZM-22100 or PV-CZM-19100, do not use the locator. Otherwise metal contacts would be damaged.

Figure 5-18 Crimping tool (H4TC0002)

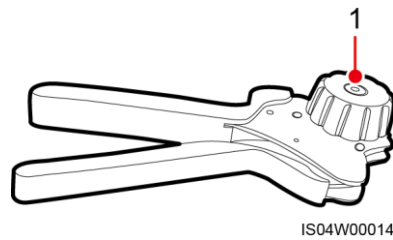

(1) Locator

Figure 5-19 Preparing positive and negative connectors (using metal cold forming contacts)

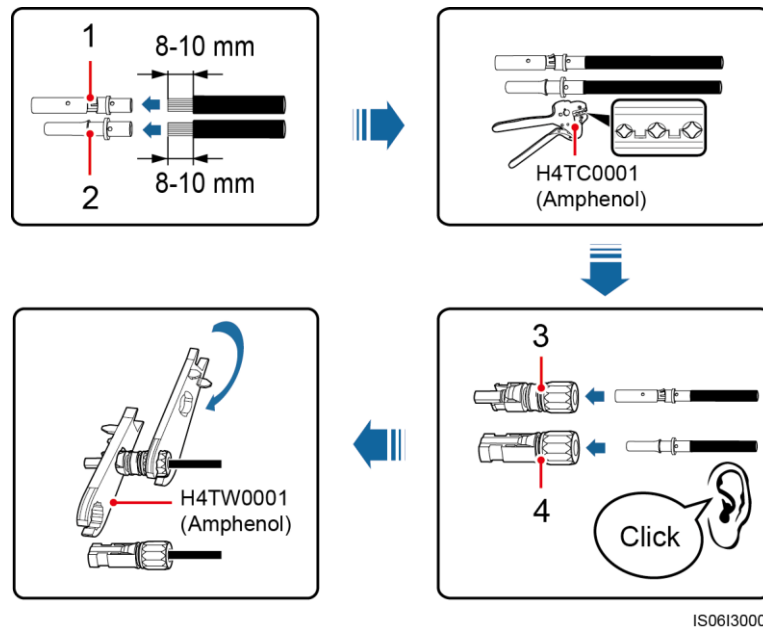

(1) Positive metal contact (cold forming)

(2) Negative metal contact (cold forming)

(3) Positive connector

(4) Negative connector

Figure 5-20 Preparing positive and negative connectors (using metal stamping forming contacts)

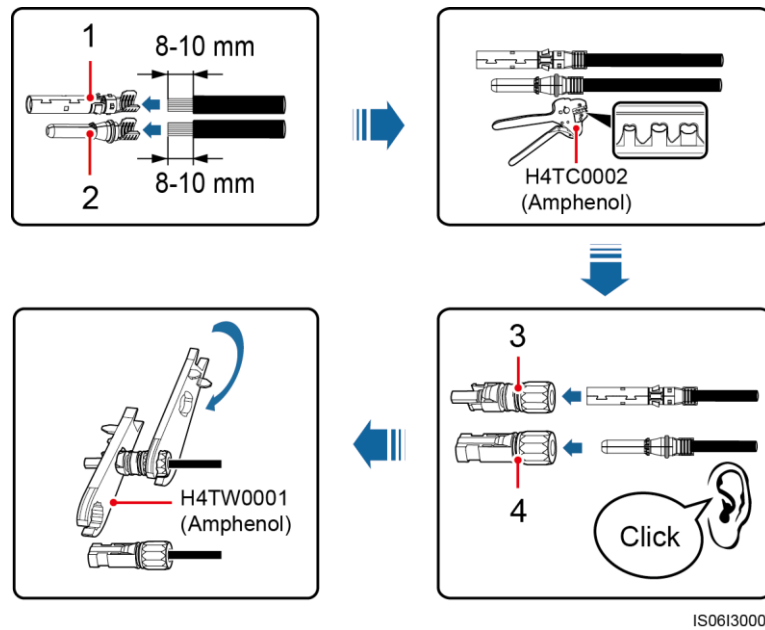

(1) Positive metal contact (stamping forming)

(2) Negative metal contact (stamping forming)

(3) Positive connector

(4) Negative connector

NOTICE

After the positive and negative metal terminals snap into place, pull the DC input power cables back to ensure that they are connected securely.

Step 2 Use a multimeter to measure the DC voltage between the positive and negative of the PV string and confirm the string polarity.

NOTICE

The DC voltage measurement range of the multimeter must be at least 1100 V.

Figure 5-21 Measuring voltage

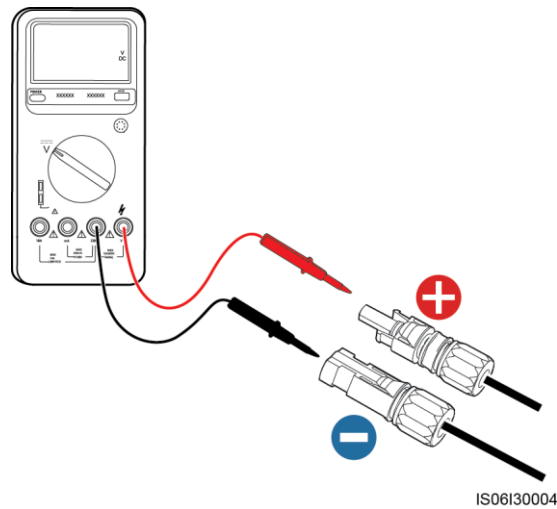

NOTICE

- If the voltage is a negative value, the PV string is of reversed polarity. Correct before connecting this string to the SUN2000.
- If the voltage is greater than 1100 V, too many PV modules are configured to the same string. Remove some PV modules.

Step 3 Pull out the blue dustproof plugs from the ends of the DC input connectors.

WARNING

Before performing [Step 4](#), ensure that the two DC switches are OFF.

Step 4 Insert the positive and negative connectors into the corresponding positive and negative DC input terminals of the SUN2000 until they snap into place.

NOTICE

After the positive and negative connectors snap into place, pull test to the DC input power cable is recommended.

Figure 5-22 Connecting DC input power cables

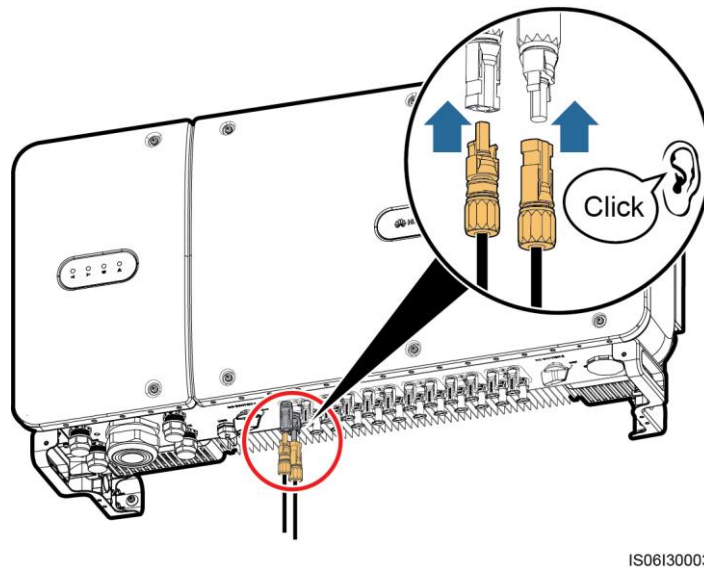

NOTICE

If polarity of the DC input power cable is reversed and the DC switch is ON, do not turn off the DC switch immediately or unplug positive and negative connectors. The device may be damaged if you do not follow the instruction. The caused equipment damage is beyond the warranty scope. Wait until the solar irradiance declines and the PV string current reduces to below 0.5 A, and then turn off the two DC switches and remove the positive and negative connectors. Correct the string polarity before reconnecting the string to the SUN2000.

----End

5.6 Installing the Communications Cable

5.6.1 Communication Mode Description

RS485 Communication

The SUN2000 can connect to the SmartLogger over RS485 and to a PC through the SmartLogger to establish communication. You can use the SUN2000 app, SmartLogger, embedded WebUI, or the network management software (such as the NetEco) on the PC to query information about the SUN2000, such as energy yields, alarms, and running status.

- [Figure 5-23](#) shows the communication mode for a single SUN2000.

Figure 5-23 Communication mode for a single SUN2000

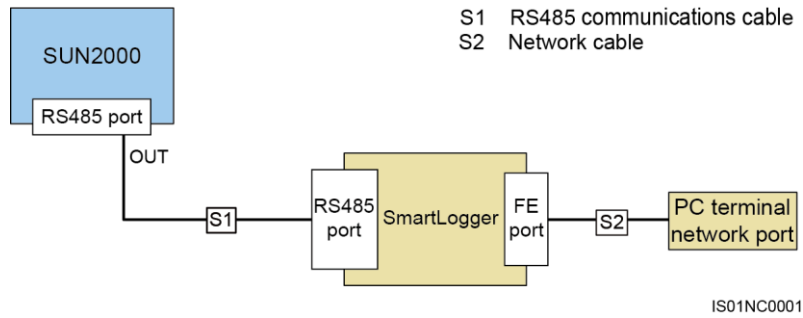

- **Figure 5-24** shows the communication mode for multiple SUN2000s. If multiple SUN2000s are used, connect all the SUN2000s in daisy chain mode over an RS485 communications cable.

Figure 5-24 Communication mode for multiple SUN2000s

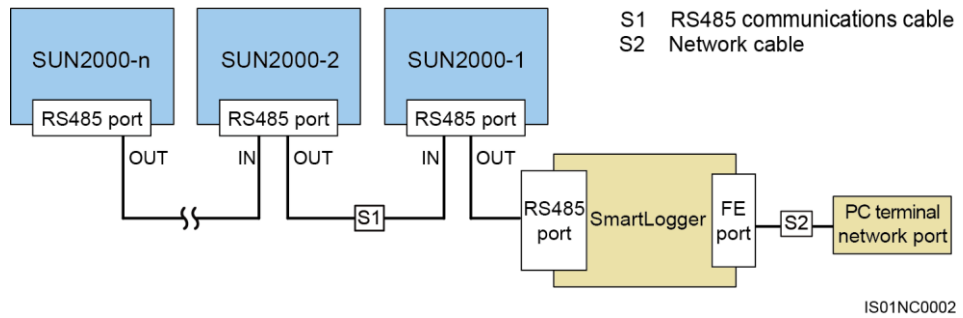

NOTE

- The RS485 communication distance between the SUN2000 at the end of the daisy chain and the SmartLogger cannot exceed 1000 meters.
- If multiple SUN2000s need to communicate with one another and are connected to a PC over the SmartLogger1000, a maximum of three daisy chains can be configured.
- If multiple SUN2000s need to communicate with one another and are connected to a PC over the SmartLogger2000, a maximum of six daisy chains can be configured.
- To ensure the system response speed, it is recommended that the number of devices on each daisy chain be less than 30.

PLC Communication

The PLC communication board loads communication signals onto power cables for transmission. For details about how to install the PLC module, see the *PLC CCO01A User Manual* or *SmartLogger2000 User Manual*.

NOTE

The built-in PLC module in the SUN2000 does not need to be connected with additional cables.

Selecting a Communication Mode

The RS485 and PLC communication modes are mutually exclusive.

- If PLC is used, do not connect the RS485 communications cable. In addition, you need to set **PLC Communication** to **Enable** on the SUN2000 app.
- If the RS485 communication mode is selected, do not connect the PLC CCO module to the AC power cable or connect the AC power cable for the SmartLogger2000. In addition, you are advised to set **PLC Communication** to **Disable** on the SUN2000 app.

NOTICE

- The PLC communication mode is only applicable to medium-voltage grid connection scenarios and non-low-voltage public grid connection scenarios (industrial environment).
 - **PLC Communication** is set to **Enable** by default.
-

5.6.2 Installing the RS485 Communications Cable

Selecting an Installation Mode

An RS485 communications cable can be connected in two ways:

- Terminal block connection
Recommended: DJYP2VP2-22 2x2x1 PC cable or communications cable with a conductor cross-sectional area of 1 mm² and a cable outer diameter of 14–18 mm.
- RJ45 network port connection
Recommended: CAT 5E outdoor shielded network cable with an outer diameter less than 9 mm and internal resistance no greater than 1.5 ohms/10 m, with a shielded RJ45 connector.

**NOTE**

Select only one installation mode in practice. Terminal block connection is recommended.

NOTICE

When laying out communications cables, separate them from power cables to avoid strong signal interference sources.

5.6.2.1 Terminal Block Connection

Terminal Block Port Definitions

Figure 5-25 shows an RS485 terminal block.

Figure 5-25 Terminal block

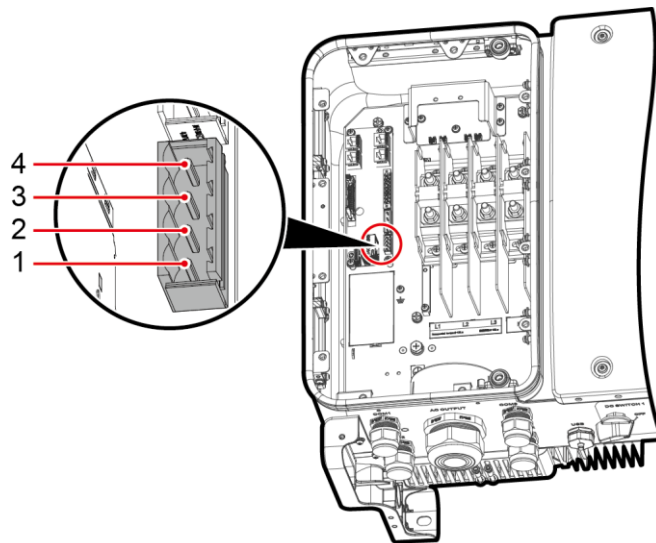

IS06W00023

Table 5-3 Port definitions of the RS485 terminal block

No.	Port Definition	Description
1	RS485A IN	RS485A, differential signal+
2	RS485A OUT	RS485A, differential signal+
3	RS485B IN	RS485B, differential signal-
4	RS485B OUT	RS485B, differential signal-

Connecting Cables to the Terminal Block

Step 1 Remove an appropriate length of the jacket and core wire insulation layer from the communications cable using a wire stripper.

Figure 5-26 Stripping an RS485 communications cable

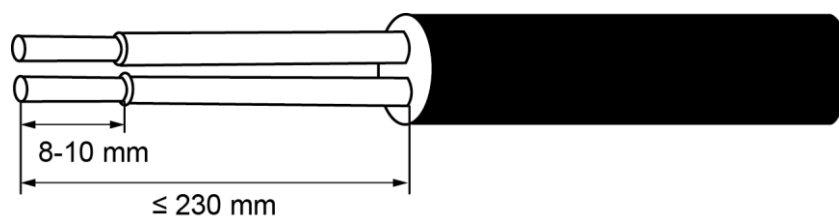

IS06H00037

Step 2 Route the communications cable through the cable gland.

Figure 5-27 Routing a cable

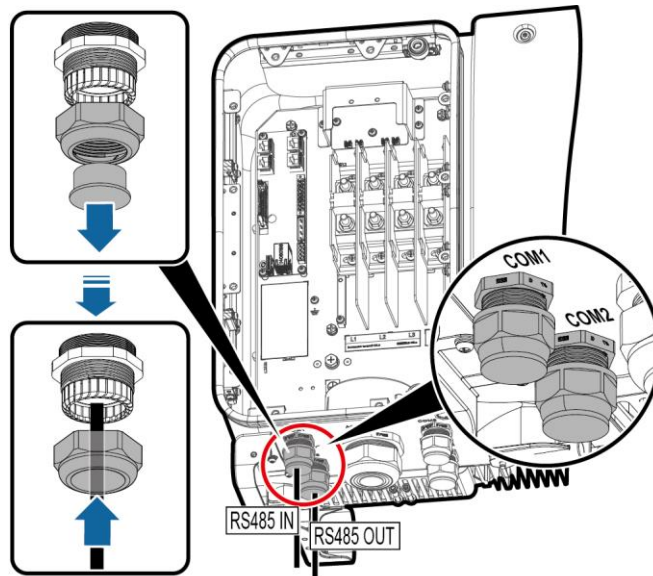

Step 3 Remove the cable terminal base from the terminal block, and connect the communications cable to the terminal base.

Figure 5-28 Connecting cables to a terminal base

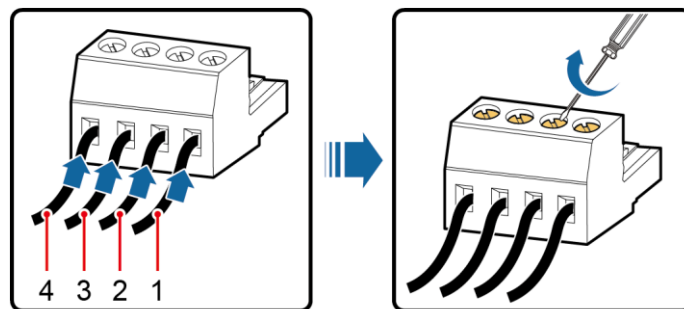

(1) RS485A IN

(2) RS485A OUT

(3) RS485B IN

(4) RS485B OUT

Step 4 Land the cables in the terminal block, and bond the shield layer to the ground point.

NOTE

When connecting the shielded cable, crimp the OT terminal if required.

Figure 5-29 Connecting communications cables

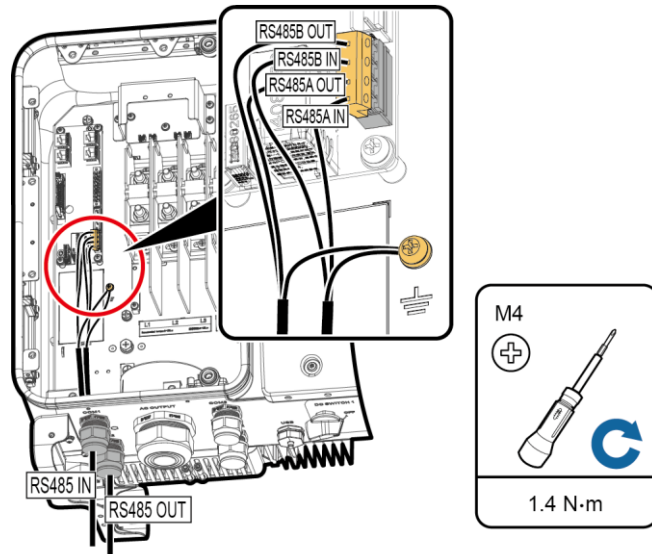

IS06I40007

Step 5 Bundle communications cables after connecting them.

Figure 5-30 Bundling communications cables

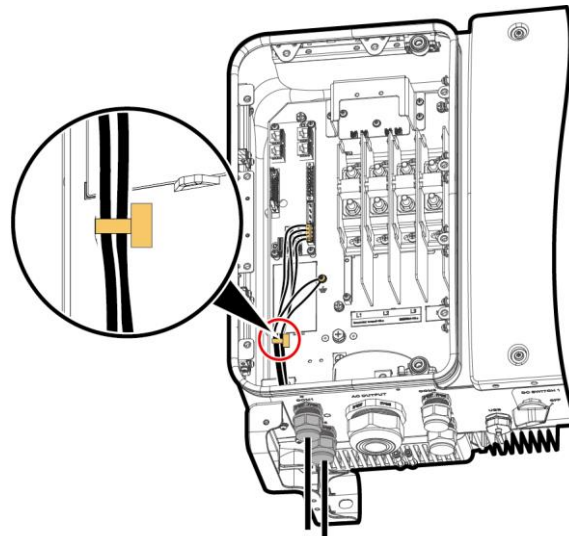

IS06H00072

Step 6 Tighten the thread-lock sealing nut and seal the waterproof connector.

----End

5.6.2.2 Connecting Cables to the RJ45 Network Port

RJ45 Connector Pin Definitions

Figure 5-31 shows an RJ45 connector.

Figure 5-31 RJ45 connector

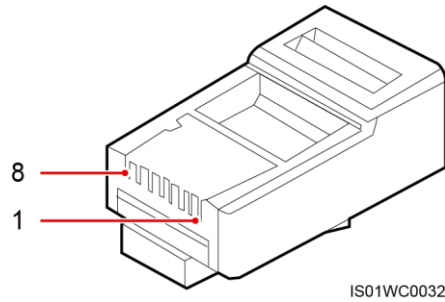

Table 5-4 lists the RJ45 connector pin definitions.

Table 5-4 RJ45 connector pin definitions

Pin	Color	Function
1	White-and-orange	RS485A, differential signal+
2	Orange	RS485B, differential signal-
3	White-and-green	N/A
4	Blue	RS485A, differential signal+
5	White-and-blue	RS485B, differential signal-
6	Green	N/A
7	White-and-brown	N/A
8	Brown	N/A

Connecting Cables to the RJ45 Network Port

Step 1 Prepare an RJ45 connector.

Figure 5-32 Preparing an RJ45 connector

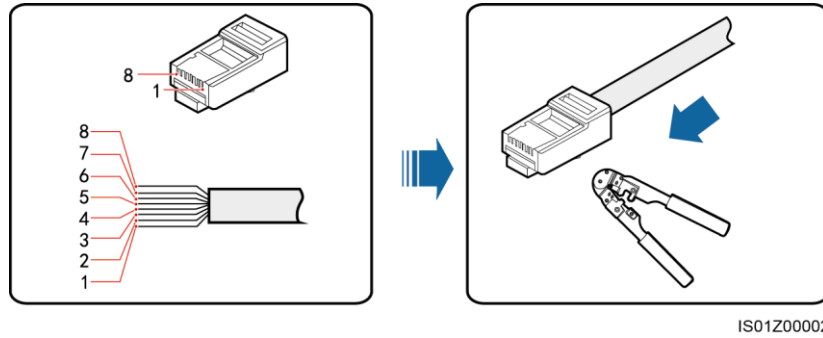

IS01Z00002

- | | | | |
|----------------------|------------|---------------------|-----------|
| (1) White-and-orange | (2) Orange | (3) White-and-green | (4) Blue |
| (5) White-and-blue | (6) Green | (7) White-and-brown | (8) Brown |

Step 2 Route the communications cable through the cable gland.

Figure 5-33 Routing a cable

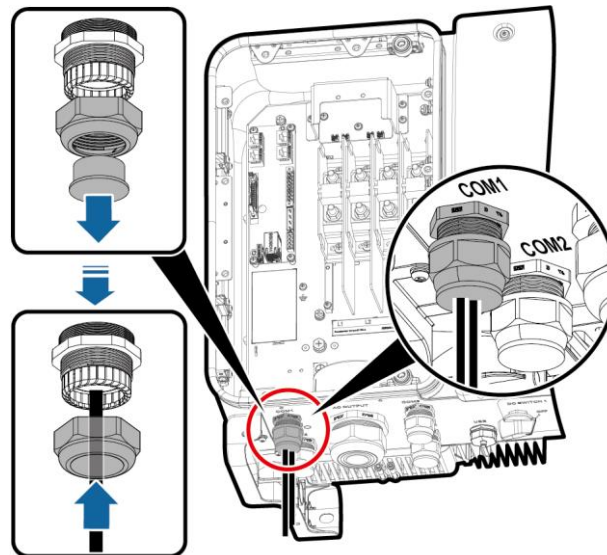

IS06H00073

Step 3 Insert the RJ45 connector into the RJ45 network port in the SUN2000 maintenance compartment.

Figure 5-34 Connecting communications cables

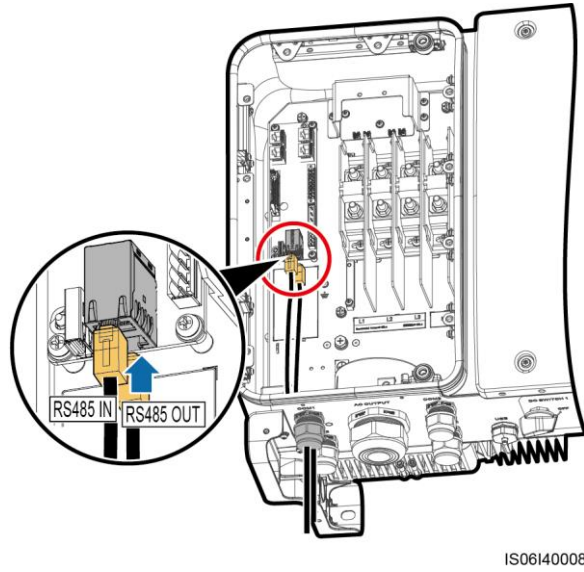

Step 4 Bundle communications cables after connecting them.

Figure 5-35 Bundling communications cables

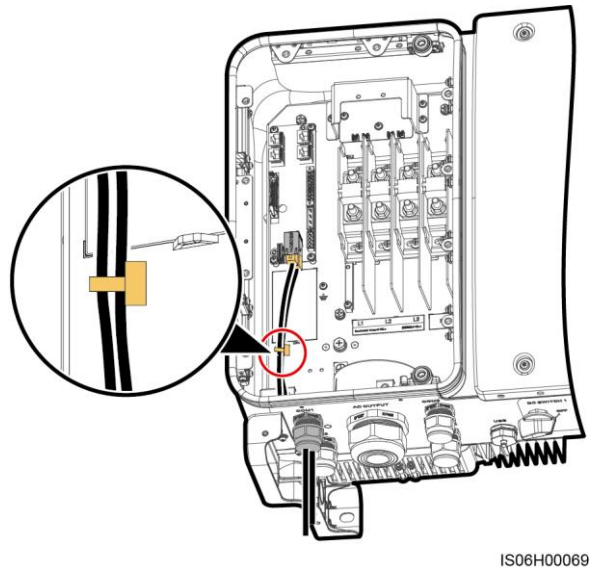

Step 5 Tighten the thread-lock sealing nut and seal the waterproof connector.

----End

5.7 Closing the Maintenance Compartment Door

Procedure

Step 1 Install the AC terminal cover.

Figure 5-36 Installing a cover

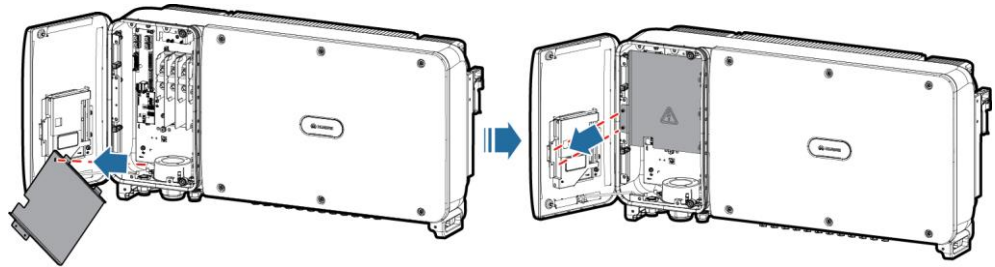

IS06H00064

Step 2 Retrieve the support bar.

Figure 5-37 Retrieving a support bar

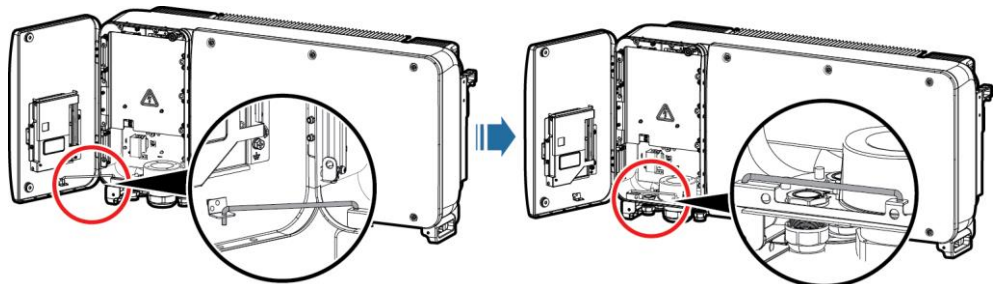

IS06H00024

Step 3 Close the maintenance compartment door and tighten the two screws on the door.

Figure 5-38 Tightening screws

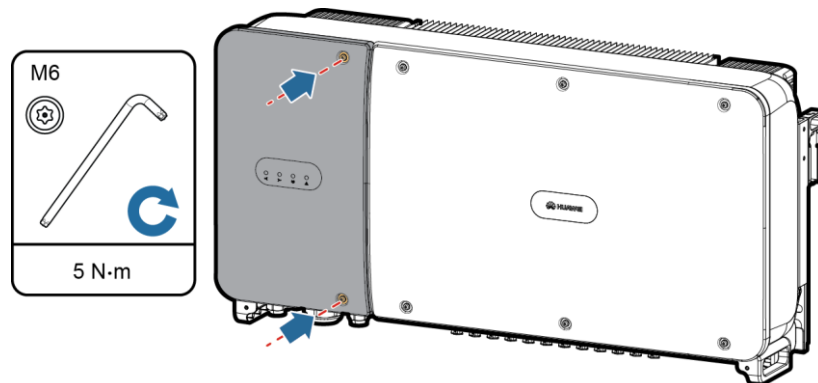

IS06H00022

----End

6 Commissioning

6.1 Checking Before Power-On

1. Check that the SUN2000 is installed correctly and securely.
2. Check that the DC switch and downstream AC output switch are OFF.
3. Check that all ground cables are connected correctly and securely.
4. Check that all AC output power cables are connected correctly and securely, without open circuits or short circuits.
5. Check that all DC input power cables are connected correctly and securely, without open circuits or short circuits.
6. Check that the communications cable is connected correctly and securely.
7. Check that all used cable glands at the bottom of the enclosure are sealed, and that the thread-lock sealing nut is tightened.
8. Check that the AC terminal cover is reinstalled.
9. Check that the maintenance compartment interior is clean and tidy, without foreign matter.
10. Check that the maintenance compartment door is closed and the door screws are tightened.
11. Check that unused DC input terminals are sealed.
12. Check that unused USB port is plugged with watertight cap.
13. Check that unused cable glands are plugged and the thread-lock sealing nuts are tightened.

6.2 Powering On the SUN2000

Precautions

NOTICE

Before turning on the AC switch between the SUN2000 and the power grid, use a multimeter to check that the AC voltage is within the specified range.

Procedure

Step 1 Turn on the AC switch between the SUN2000 and the power grid.

NOTICE

If you perform [Step 2](#) before [Step 1](#), the SUN2000 reports a fault about abnormal shutdown. You can start the SUN2000 only after the fault is automatically rectified.

Step 2 Turn on the DC switch at the bottom of the SUN2000.

Step 3 Connect the SUN2000 to the mobile phone that runs SUN2000 app through a Bluetooth module or USB data cable.

NOTICE

- When the iOS is used, the app supports only Bluetooth connection.
- The screenshots in this document correspond to SUN2000 app 2.2.00.038.

Figure 6-1 Bluetooth module connection

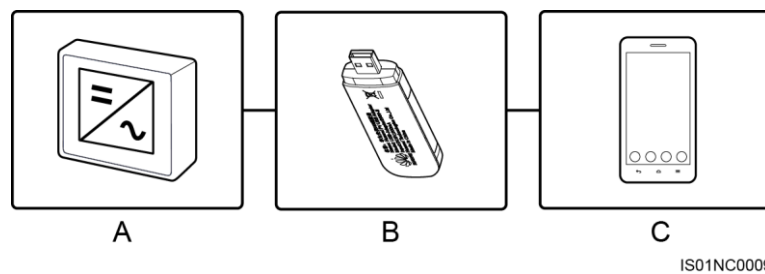

(A) SUN2000

(B) Bluetooth module

(C) Mobile phone



NOTE

Purchase the Bluetooth module bundled with the SUN2000. A Bluetooth module purchased from any other source may not support communication between the SUN2000 and the app.

Figure 6-2 Data cable connection

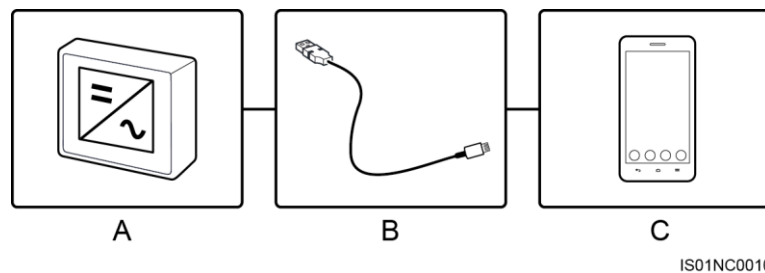

(A) SUN2000

(B) USB data cable

(C) Mobile phone



NOTE

Use the USB data cable delivered with the mobile phone. The port type is USB 2.0.

Figure 6-3 Login screen

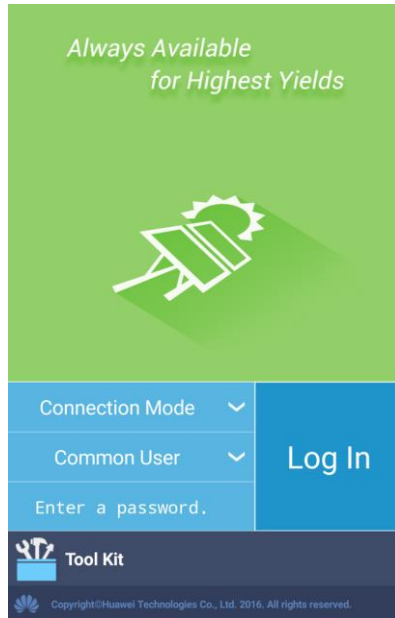

Figure 6-4 Selecting a connection mode

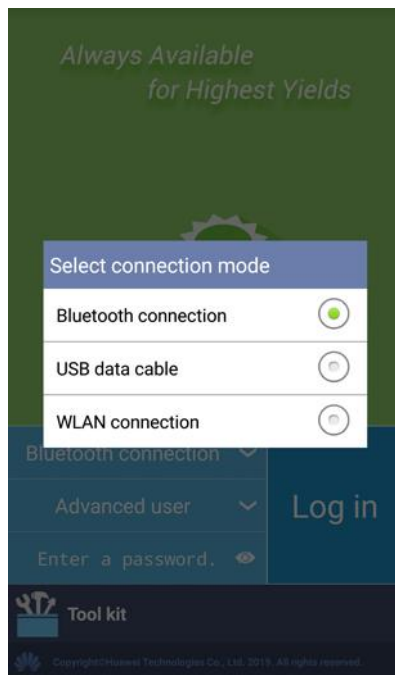

Figure 6-5 Bluetooth connection

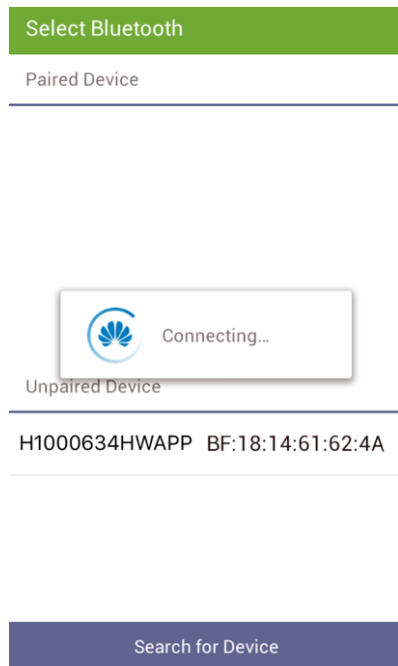
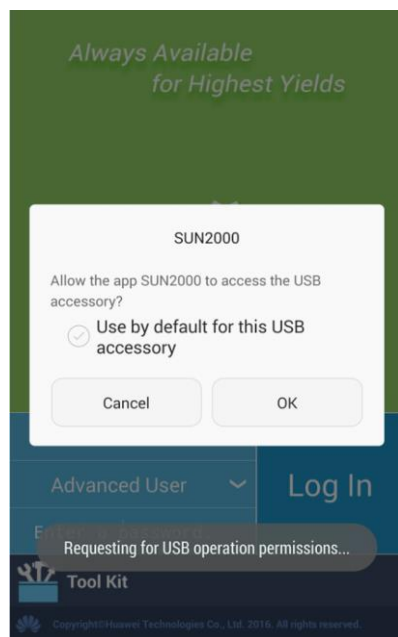

Figure 6-6 Data cable connection



NOTE

After you select **Use by default for this USB accessory**, the message that asks you whether the SUN2000 app is allowed to access the USB will not appear if you reconnect the app without disconnecting the USB data cable.

Step 4 Tap the user name area on the SUN2000 app to switch between **Common User**, **Advanced User**, and **Special User**.

Figure 6-7 Switching between users

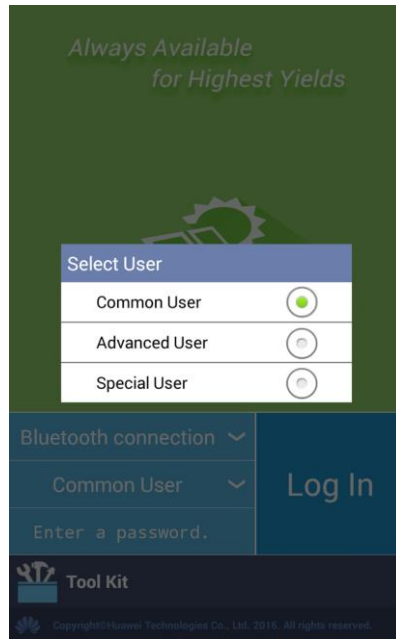

 **NOTE**

- The login password is the same as that for the SUN2000 connected to the app and is used only for the SUN2000 to connect to the app.
- The initial passwords for **Common User**, **Advanced User**, and **Special User** are all **00000a**. Use the initial password upon first login. To ensure account security, change the password immediately after login.
- During login, if five consecutive invalid password attempts are made (the interval between two consecutive attempts is less than 2 minutes), the account will be locked for 10 minutes. The password should consist of 6 characters.

Step 5 Enter the password and tap **Log In**.

Step 6 After successful login, the quick settings screen or main menu screen is displayed.

 **NOTE**

- If you log in to the SUN2000 app after the device connects to the app for the first time or factory defaults are restored, the quick settings screen will be displayed. On the quick settings screen, you can set basic parameters. After settings, you can modify the parameters by tapping **Settings** on the main menu screen. If the AC switch between the SUN2000 and the power grid is turned on but both of **DC SWITCH** on the SUN2000 are not in the **ON** position, no option is available for **Grid code** on the quick settings screen.
- You are advised to log in to the **Quick Settings** screen as **Advanced User** for parameter settings.
- Set the correct grid code based on the application region and scenario of the SUN2000.

Figure 6-8 Quick Settings screen (advanced user)

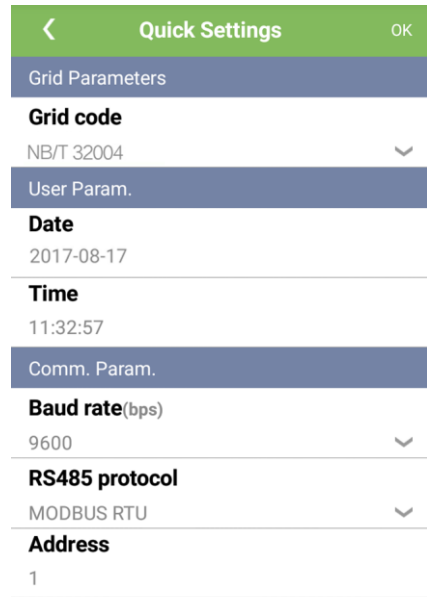

NOTE

- Set the grid code that applies to the country or region where the PV plant is located and the SUN2000 model.
- Set user parameters based on the current date and time.
- Set **Baud rate**, **Protocol**, and **Address** based on site requirements. **Baud rate** can be set to **4800**, **9600**, or **19200**. **Protocol** can be set to **MODBUS RTU**, and **Address** can be set to any value in the range of 1 to 247.
- When multiple SUN2000s communicate with the SmartLogger over RS485, the RS485 addresses for all the SUN2000s on each RS485 route must be within the address range set on the SmartLogger and cannot be duplicate. Otherwise, the communication will fail. In addition, the baud rates of all the SUN2000s on each RS485 route must be consistent with the SmartLogger baud rate.

Figure 6-9 Main menu screen

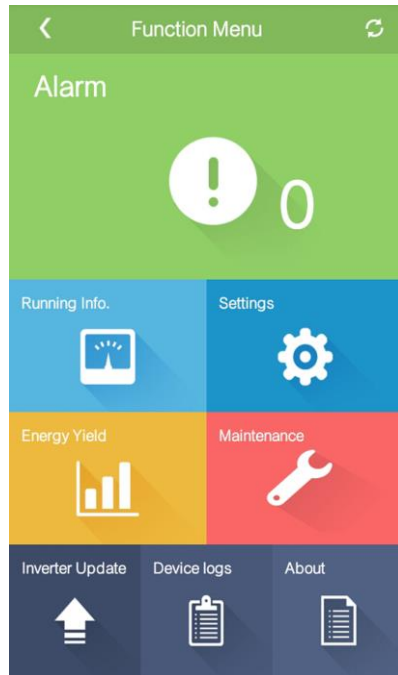

----End

6.3 (Optional) 4G Communication Commissioning

4G Networking

4G communication mainly applies in the distributed PV plants with smaller numbers of inverters. The inverters directly connect to the FusionSolar management system through the 4G network.



NOTE

4G networking is supported in China only.

Figure 6-10 Networking

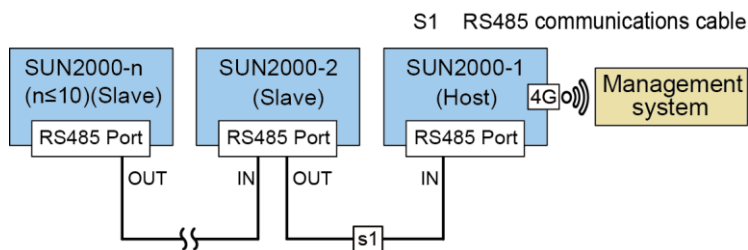

IS01W00074



NOTE

Install the 4G module on the SUN2000 host. RS485 communication is used between the SUN2000 host and slave, and between the SUN2000 slave and slave.

Setting Communications Parameters

- Step 1** Power on the SUN2000. For details, see [6.2 Powering On the SUN2000](#).
- Step 2** Log in to the SUN2000 app as **Advanced User**.
- Step 3** Choose **Function Menu > Settings > Comm. Param.** to access the settings screen.

Figure 6-11 Communications parameters

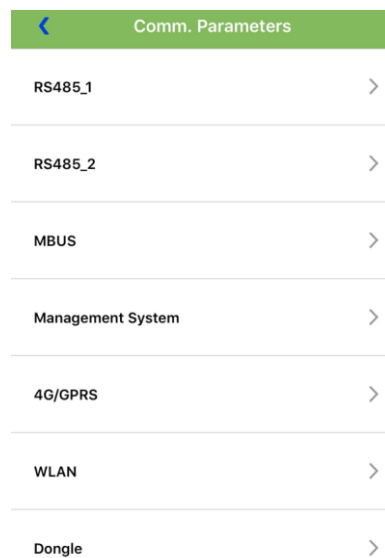

- Step 4** Tap **Management System**.

Figure 6-12 Management System parameters

Management System

CD Key No.
0GZ95YHOJDNM

NMS server
XX.XX.XX.XX

NetEco server port
XXXXX

SSL encryption

Cascading Channel

Replace Certificate >

Heartbeat period at application layer
30

TCP frame length
1200



NOTE

Set Management System for the SUN2000 host (configured with the 4G module) only.

- Enter the correct NMS server domain name or IP address.
- Enter the correct port number of the NMS server.
- If **SSL encryption** is set to **Disable**, data will be transmitted without being encrypted, which may pose security risks. Therefore, exercise caution with the setting.
- Set **Cascading Channel** of the host to **Enable**, and set **Cascading Channel** of the slave to **Disable**. (**Cascading Channel** is set to **Disable** by default.)
- For **Heartbeat period at application layer** and **TCP frame length**, retain the default value.

----End

Installing a 4G Module

Step 1 After setting **Comm. Param.**, remove the Bluetooth module or USB data cable.



NOTE

- If the 4G module is configured with a SIM card, there is no need to perform [Step 2](#).
- If it is not configured with a SIM card, prepare a standard one (dimensions: 25 mm x 15 mm, capacity \geq 64 KB).
- When installing the SIM card, determine its installation direction based on the silk screen and arrow on the card slot.
- Press the SIM card in place to lock it. The SIM card is correctly installed.
- When removing the SIM card, push it inwards to eject it.
- When reinstalling the 4G module cover, ensure that the buckle springs back in place.

Step 2 Press the buckle inwards, remove the 4G module cover, and install the SIM card.

Figure 6-13 Installing a SIM card

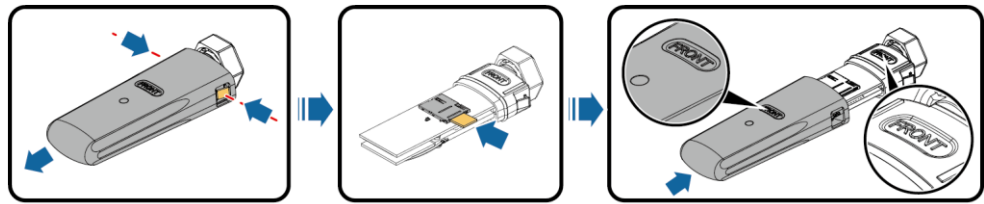

IS05H00010

Step 3 Securing a 4G module

Figure 6-14 Securing a 4G module

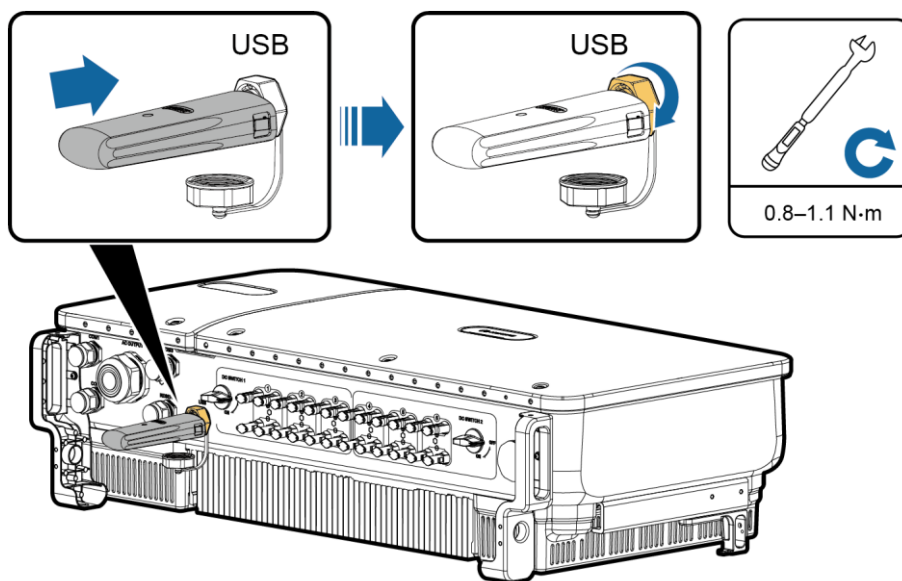

IS06H00061

Step 4 Wait for about 15s for dialup and then observe the LED indicator on the 4G module to check the module status.

Table 6-1 LED indicator status description

Indicator Status	4G Module Working Status	Quick Check
Blinking: The indicator blinks at intervals of 2s, on for 0.1s and off for 0.1s, then on for 0.1s and off for 1.7s.	The service is unavailable.	No SIM card is installed or the SIM card is not properly connected.
Blinking: The indicator blinks at intervals of 2s, on for 0.1s and off for 1.9s.	The network is successfully connected.	The 4G module is waiting for communication setup.
Steady on	Communication is in progress.	The 4G module is working properly.

Indicator Status	4G Module Working Status	Quick Check
Off	The module is powered off.	The 4G module is not properly connected or damaged, or the USB port is not energized.

NOTICE

The SUN2000 has only one USB port. Before performing local maintenance on the SUN2000 host, you need to remove the 4G module, which will interrupt the communication between the SUN2000 host and the NMS. After finishing the local maintenance, you can reinstall the 4G module to have the communication automatically resumed.

NOTE

When the SUN2000 connects to a third-party management system, ensure that the system supports the standard Modbus-TCP protocol and configure the access point table based on the SUN2000 interface definitions. Set **NMS server** and **NetEco server port** to meet the system requirements and replace the client license. The third-party management system must comply with the SUN2000 interface definition. For details about the SUN2000 interface definitions, contact Huawei technical support.

----End

6.4 Powering Off the System

Precautions

WARNING

- If two SUN2000s share the same AC switch on the AC side, power off the two SUN2000s.
- After the SUN2000 powers off, the remaining electricity and heat may still cause electric shocks and body burns. Therefore, put on personal protective equipment (PPE) and begin servicing the SUN2000 fifteen minutes after power-off.

Procedure

Step 1 Run a shutdown command on the SUN2000 app, SmartLogger, or NMS.

For details, see the *SUN2000 App User Manual*, *SmartLogger1000 User Manual*, *SmartLogger2000 User Manual*, or *iManager NetEco 1000S User Manual*.

Step 2 Turn off the AC switch between the SUN2000 and the power grid.

Step 3 Turn off both DC switches.

----End

7 Man-Machine Interactions

7.1 Operations with a USB Flash Drive

USB flash drives of SanDisk, Netac, and Kingston are recommended. Other brands may be incompatible.

7.1.1 Exporting Configurations

Procedure

- Step 1** Choose **Tool Kit > Local maint script > Inverter Command Settings** on the SUN2000 app to generate a boot script file for exporting configuration (boot script file for short).
- Step 2** Import the boot script file to a PC.

(Optional) The boot script file can be opened as a .txt file, as shown in [Figure 7-1](#).

Figure 7-1 Boot script file

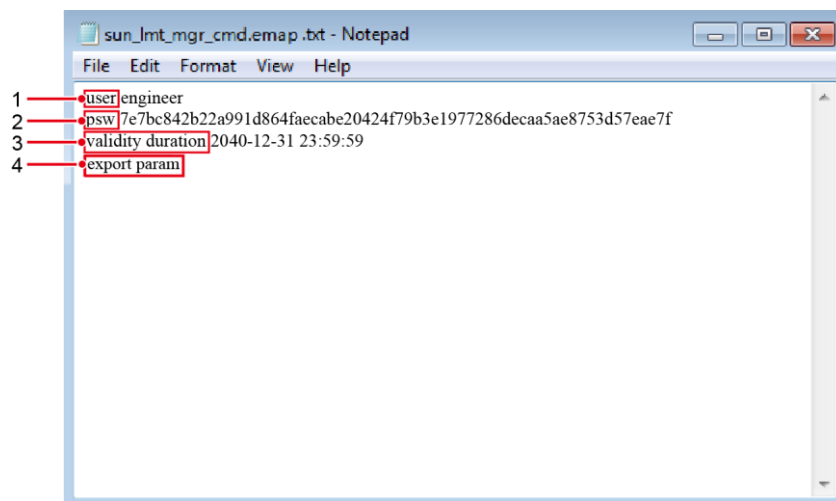

No.	Meaning	Remarks
1	User name	<ul style="list-style-type: none"> Advanced user: engineer Special user: admin
2	Ciphertext	The ciphertext varies depending on the login password of the SUN2000 app.
3	Script validity period	-
4	Command	Different command settings can produce different commands. <ul style="list-style-type: none"> Configuration export command: export param. Configuration import command: import param. Data export command: export log. Upgrade command: upgrade.

Step 3 Import the boot script file to the root directory of a USB flash drive.

Step 4 Connect the USB flash drive to the USB port. The system automatically identifies the USB flash drive and executes all commands specified in the boot script file. View the LED indicator to determine the operating status.

NOTICE

Verify that the ciphertext in the boot script file matches the login password of the SUN2000 app. If they do not match and you insert the USB flash drive for five consecutive times, the user account will be locked for 10 minutes.

Table 7-1 LED indicator description

LED Indicator	Status	Meaning
	Green off	There is no operation with a USB flash drive.
	Blinking green at long intervals (on for 1s and then off for 1s)	There is an operation with a USB flash drive.
	Blinking green at short intervals (on for 0.125s and then off for 0.125s)	An operation with a USB flash drive has failed.
	Steady green	An operation with a USB flash drive is successful.

Step 5 Insert the USB flash drive into a computer and check the exported data.



NOTE

When the configuration export is complete, the boot script file and exported file are in the root directory of the USB flash drive.

----End

7.1.2 Importing Configuration

Prerequisites

A complete configuration file has been exported.

Procedure

- Step 1** Choose **Tool Kit > Local maint script > Inverter Command Settings** on the SUN2000 app to generate a boot script file for importing configuration.
- Step 2** Import boot script file for importing configuration to a PC.
- Step 3** Replace the boot script file for exporting configuration in the root directory of the USB flash drive with the one for importing configuration.

NOTICE

Replace the boot script file only and keep the exported file.

- Step 4** Connect the USB flash drive to the USB port. The system automatically identifies the USB flash drive and executes all commands specified in the boot script file. View the LED indicator to determine the operating status.

NOTICE

Verify that the ciphertext in the boot script file matches the login password of the SUN2000 app. If they do not match and you insert the USB flash drive for five consecutive times, the user account will be locked for 10 minutes.

Table 7-2 LED indicator description

LED Indicator	Status	Meaning
	Green off	There is no operation with a USB flash drive.
	Blinking green at long intervals (on for 1s and then off for 1s)	There is an operation with a USB flash drive.
	Blinking green at short intervals (on for 0.125s and then off for 0.125s)	An operation with a USB flash drive has failed.
	Steady green	An operation with a USB flash drive is successful.

----End

7.1.3 Exporting Data

Procedure

- Step 1** Choose **Tool Kit > Local maint script > Inverter Command Settings** on the SUN2000 app to generate a boot script file for exporting data (boot script file for short).
- Step 2** Import the boot script file to a PC.
- Step 3** Connect the USB flash drive to the USB port. The system automatically identifies the USB flash drive and executes all commands specified in the boot script file. View the LED indicator to determine the operating status.

NOTICE

Verify that the ciphertext in the boot script file matches the login password of the SUN2000 app. If they do not match and you insert the USB flash drive for five consecutive times, the user account will be locked for 10 minutes.

Table 7-3 LED indicator description

LED Indicator	Status	Meaning
	Green off	There is no operation with a USB flash drive.
	Blinking green at long intervals (on for 1s and then off for 1s)	There is an operation with a USB flash drive.
	Blinking green at short intervals (on for 0.125s and then off for 0.125s)	An operation with a USB flash drive has failed.
	Steady green	An operation with a USB flash drive is successful.

- Step 4** Insert the USB flash drive into a PC and check the exported data.



NOTE

After the data is exported, the boot script file and exported data file are saved in the root directory of the USB flash drive.

----End

7.1.4 Upgrading

Procedure

- Step 1** Obtain the software upgrade package from the technical support website.
- Step 2** Decompress the upgrade package.

NOTICE

- When the login password of the SUN2000 app is the initial password (**00000a**), there is no need to perform [Step 3–Step 5](#).
- When the login password of the SUN2000 app is not the initial password, perform [Step 3–Step 7](#).

- Step 3** On the SUN2000 app, choose **Tool Kit > Local maint script > Inverter Command Settings** to generate an upgrade boot script file (boot script file for short).
- Step 4** Import the boot script file to a PC.
- Step 5** Replace the boot script file in the upgrade package (sun_lmt_mgr_cmd.emap) with the one generated by the SUN2000 app.
- Step 6** Copy the extracted files to the root directory of the USB flash drive.
- Step 7** Connect the USB flash drive to the USB port. The system automatically identifies the USB flash drive and executes all commands specified in the boot script file. View the LED indicator to determine the operating status.

NOTICE

Verify that the ciphertext in the boot script file matches the login password of the SUN2000 app. If they do not match and you insert the USB flash drive for five consecutive times, the user account will be locked for 10 minutes.

Table 7-4 LED indicator description

LED Indicator	Status	Meaning
	Green off	There is no operation with a USB flash drive.
	Blinking green at long intervals (on for 1s and then off for 1s)	There is an operation with a USB flash drive.
	Blinking green at short intervals (on for 0.125s and then off for 0.125s)	An operation with a USB flash drive has failed.
	Steady green	An operation with a USB flash drive is successful.

- Step 8** (Optional) The system automatically restarts when the upgrade is completed. All LED indicators are off during the restart. After the restart, the preceding indicator is blinking green slowly (on for 1s and then off for 1s) for 1 minute until becoming steady on, which indicates that the upgrade is successful.



NOTE

The SUN2000 can also be locally upgraded through the **Inverter Upgrade** on the SUN2000 app. For details, see the *SUN2000 APP User Manual*.

----End

7.2 Operations with the SUN2000 App

NOTICE

When you use the SUN2000 app to set parameters for the SUN2000, setting items on certain parameter setting screens are not displayed if the AC switch between the SUN2000 and the power grid is turned on but both of **DC SWITCH** on the SUN2000 are not in the **ON** position. Switch both of **DC SWITCH** to the **ON** position and then reset relevant parameters again.



NOTE

- The app version is 2.2.00.020.
- Configurable parameters vary depending on the grid code. The actual display prevails.
- If you change the grid code, some parameters may be restored to factory defaults. After the grid code is changed, check whether the previously set parameters are affected.
- The parameter names, value ranges, and default values are subject to change. The actual display prevails.

7.2.1 Operations Related to the Advanced User

If you log in to the app as **Advanced User**, you can set grid parameters, protection parameters, and feature parameters for the SUN2000.

7.2.1.1 Setting Grid Parameters

Procedure

Step 1 Tap **Function Menu > Settings > Grid Parameters** to access the parameters setting screen.

Figure 7-2 Grid parameters (advanced user)

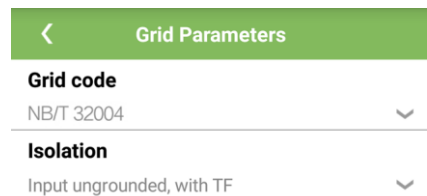

----End

Parameter List

No.	Parameter	Description	Default Value	Value Range
1	Grid code	Set this parameter based on the grid code of the country or region where the SUN2000 is used and the SUN2000 application scenario.	<ul style="list-style-type: none"> SUN2000-50KTL-M0: KOREA SUN2000-60KTL-M0: NB/T 32004 	N/A
2	Isolation	Specifies the working mode of the SUN2000 according to the grounding status at the DC side and the connection status to the grid.	Input not grounded, with a transformer	<ul style="list-style-type: none"> Input ungrounded, without TF Input ungrounded, with TF

7.2.1.2 Setting Protect Parameters

Procedure

Step 1 Choose **Function Menu > Settings > Protect Parameters** to access the settings screen.

Figure 7-3 Protect parameters (advanced user)



----End

Parameter List

No.	Parameter	Description	Unit	Default Value	Value Range
1	Insulation resistance protection	To ensure device safety, the SUN2000 detects the insulation resistance between the input side and the ground when it starts a self-check. If the detected value is less than the preset value, the SUN2000 does not export power to the power grid.	MΩ	0.050	[0.033, 1.500]

7.2.1.3 Setting Feature Parameters

Procedure

Step 1 Choose **Function Menu > Settings > Feature Parameters** to access the settings screen.

Figure 7-4 Feature parameters (advanced user)

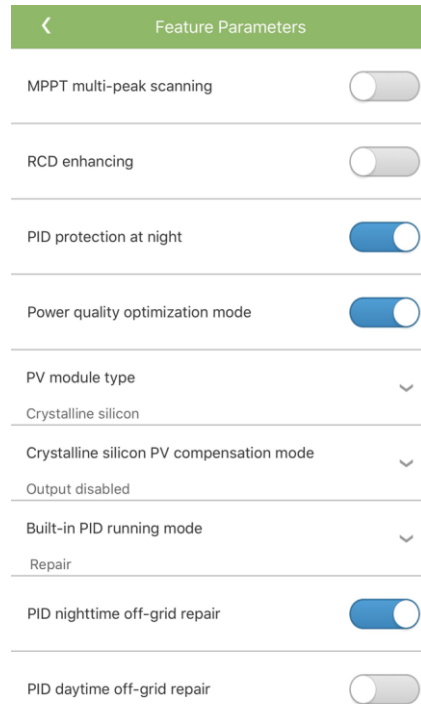

----End

Parameter List

No.	Parameter	Description	Unit	Default Value	Value Range	Remarks
1	MPPT multi-peak scanning	When the SUN2000 is used in scenarios where PV strings are obviously shaded, enable this function. Then the SUN2000 will perform MPPT scanning at regular intervals to locate the maximum power.	-	Disable	<ul style="list-style-type: none"> Disable Enable 	The scanning interval is set by MPPT multi-peak scanning interval .

No.	Parameter	Description	Unit	Default Value	Value Range	Remarks
2	MPPT multi-peak scanning interval	Specifies the MPPT multi-peak scanning interval.	min	15	[5, 30]	This parameter is displayed only when MPPT multi-peak scanning is set to Enable .
3	RCD enhancing	RCD refers to the residual current of the SUN2000 to the ground. To ensure device security and personal safety, RCD should comply with the standard. If an AC switch with a residual current detection function is installed outside the SUN2000, this function should be enabled to reduce the residual current generated during SUN2000 running, thereby preventing the AC switch from misoperations.	-	Disable	<ul style="list-style-type: none"> • Disable • Enable 	-
4	Reactive power output at night	In some specific application scenarios, a power grid company requires that the SUN2000 can perform reactive power compensation at night to ensure that the power factor of the local power grid meets requirements.	-	Disable	<ul style="list-style-type: none"> • Disable • Enable 	This parameter is configurable only when Isolation is set to Input ungrounded, with a transformer .

No.	Parameter	Description	Unit	Default Value	Value Range	Remarks
5	PID protection at night	<ul style="list-style-type: none"> When PID protection at night is set to Enable, the SUN2000 will shut down automatically if it detects abnormality in PID voltage compensation during the reactive power compensation at night. When PID protection at night is set to Disable, the SUN2000 will operate in grid-tied mode if it detects abnormality in PID voltage compensation during the reactive power compensation at night. 	-	Enable	<ul style="list-style-type: none"> Disable Enable 	-
6	Power quality optimization mode	If Power quality optimization mode is set to Enable , the inverter output current harmonics will be optimized.	-	Enable	<ul style="list-style-type: none"> Disable Enable 	-

No.	Parameter	Description	Unit	Default Value	Value Range	Remarks
7	PV module type	This parameter is used to set different types of PV modules and the shutdown time of the concentration PV modules. If the concentration PV modules are shaded, the power drops drastically to 0 and the SUN2000 shuts down. The energy yield would be affected since it takes too long for the power to resume and SUN2000 to restart. The parameter does not need to be set for crystalline silicon and filmy PV modules.	-	Crystalline silicon	<ul style="list-style-type: none"> • Crystalline silicon • Film • CPV 1 • CPV 2 	<ul style="list-style-type: none"> • If PV module type is set to Crystalline silicon or Film, the SUN2000 automatically detects the power of PV modules when they are shaded and shuts down if the power is too low. • When the concentration PV modules are used: <ul style="list-style-type: none"> - If PV module type is set to CPV 1, the inverter can quickly restart in 60 minutes when the input power of PV modules drops drastically due to shading. - If PV module type is set to CPV 2, the inverter can quickly restart in 10 minutes when the input power of PV modules drops drastically due to shading.

No.	Parameter	Description	Unit	Default Value	Value Range	Remarks
8	Crystalline silicon PV compensation mode	The PID effect may result in the power attenuation of PV modules, which is mainly caused by the DC voltage between PV modules and the ground. Enabling this setting lowers the DC voltage between PV modules and the ground by reducing the impedance on the input side to the ground.	-	Disable output	<ul style="list-style-type: none"> • Disable output • PV- positive offset • PV+ negative offset 	This parameter is displayed only if PV module type is set to Crystalline silicon .
9	Built-in PID running mode	Specifies the operation mode of the SUN2000 built-in PID.	-	Repair	<ul style="list-style-type: none"> • Disable • Repair 	This parameter is displayed only for the models that support Built-in PID repair .
10	PID nighttime off-grid repair	Specifies whether to enable the PID nighttime off-grid repair.	-	Enable	<ul style="list-style-type: none"> • Disable • Enable 	This parameter is displayed only if Built-in PID running mode is set to Repair .
11	PID daytime off-grid repair	Specifies whether to enable the PID daytime off-grid repair.	-	Disable	<ul style="list-style-type: none"> • Disable • Enable 	This parameter is displayed only if Built-in PID running mode is set to Repair .

No.	Parameter	Description	Unit	Default Value	Value Range	Remarks
12	String connection mode	<p>Specifies the connection mode of PV strings.</p> <ul style="list-style-type: none"> When the PV strings connect to the inverter separately (fully separate connection), there is no need to set this parameter. The inverter can automatically detect the connection mode of the PV strings. When the PV strings connect to one another in parallel outside the inverter and then connect to the inverter independently (fully parallel connection), set this parameter to All PV strings connected. 	-	Automatic detection	<ul style="list-style-type: none"> Automatic detection All PV strings separated All PV strings connected 	-
13	Communication interrupt shutdown	<p>The standards of certain countries and regions require that the SUN2000 must shut down after the communication is interrupted for a certain time.</p>	-	Disable	<ul style="list-style-type: none"> Disable Enable 	<p>If Communication interrupt shutdown is set to Enable and the SUN2000 communication has been interrupted for a specified time (set by Communication interruption duration), the SUN2000 will automatically shut down.</p>

No.	Parameter	Description	Unit	Default Value	Value Range	Remarks
14	Communication resumed startup	If this parameter is enabled, the SUN2000 automatically starts after communication recovers. If this parameter is disabled, the SUN2000 needs to be started manually after communication recovers.	-	Enable	<ul style="list-style-type: none"> • Disable • Enable 	-
15	Communication interruption duration	Specifies the duration for determining communication interruption, and is used for automatic shutdown for protection in case of communication interruption.	min	30	[1, 120]	-
16	Soft start time	Specifies the duration for the power to gradually increase when the SUN2000 starts.	s	20	[20, 1800]	-
17	Hibernate at night	The SUN2000 monitors PV strings at night. If Hibernate at night is set to Enable , the monitoring function of the SUN2000 will hibernate at night, reducing power consumption.	-	Disable	<ul style="list-style-type: none"> • Disable • Enable 	-
18	PLC communication	For SUN2000 models that support both RS485 and PLC communication, when RS485 communication is used, you are advised to set PLC communication to Disable to reduce power consumption.	-	Enable	<ul style="list-style-type: none"> • Disable • Enable 	-

No.	Parameter	Description	Unit	Default Value	Value Range	Remarks
19	Upgrade delay	Upgrade delay is mainly used in the upgrade scenarios where the PV power supply is disconnected at night due to no sunlight or unstable at dawn or dusk due to poor sunlight.	-	Enable	<ul style="list-style-type: none"> • Disable • Enable 	After the SUN2000 upgrade starts, if Upgrade delay is set to Enable , the upgrade package is loaded first. After the PV power supply recovers and the activation conditions are met, the SUN2000 automatically activates the upgrade.
20	String monitor	The SUN2000 monitors PV strings in real time. If any PV string is abnormal (such as the PV string is shaded or the energy yield decreases), the SUN2000 generates an alarm to remind maintenance personnel to maintain the PV string in a timely manner.	-	Disable	<ul style="list-style-type: none"> • Disable • Enable 	If PV strings are easily shaded, you are advised to set String monitor to Disable to prevent false alarms.
21	String detection reference asymmetric coefficient	Specifies the threshold for determining PV string exception. The false alarms caused by fixed shadow shading can be controlled by changing this parameter.	-	20	[5, 100]	This parameter is displayed when String monitor is set to Enable .
22	String detection starting power percentage	Specifies the threshold for starting PV string exception detection. The false alarms caused by fixed shadow shading can be controlled by changing this parameter.	%	20	[1, 100]	

No.	Parameter	Description	Unit	Default Value	Value Range	Remarks
23	Duration for determining short-time grid disconnection	The standards of certain countries and regions require that the SUN2000 should not disconnect from the power grid if the power grid experiences a short-time failure. The SUN2000 output power should be recovered immediately after the fault is rectified.	ms	3000	[500, 20000]	-

7.2.2 Operations Related to the Special User

If you log in to the app as **Special User**, you can set grid parameters, protection parameters, feature parameters, and power adjustment parameters for the SUN2000.

7.2.2.1 Setting Grid Parameters

Procedure

Step 1 Choose **Function Menu** > **Settings** > **Grid Parameters** to access the settings screen.

Figure 7-5 Grid parameters (special user)



----End

Parameter List



NOTE

- V_n represents the rated voltage and F_n represents the rated frequency.
- **PQ mode** is supported by the SUN2000-50KTL-M0.

No.	Parameter	Description	Unit	Default Value	Value Range
1	Grid code	Set this parameter based on the grid code of the country or region where the SUN2000 is used and the SUN2000 application scenario.	N/A	<ul style="list-style-type: none"> • SUN2000-50K TL-M0: KOREA • SUN2000-60K TL-M0: NB/T 32004 	N/A
2	Output mode	Specifies whether the SUN2000 has an output neutral wire based on the SUN2000 application scenario.	N/A	Three-phase four-wire	<ul style="list-style-type: none"> • Three-phase three-wire • Three-phase four-wire
3	PQ mode	If this parameter is set to PQ mode 1 , the maximum active power equals the maximum apparent power. If it is set to PQ mode 2 , the maximum active power equals the rated active power.	N/A	PQ mode 1	<ul style="list-style-type: none"> • PQ mode 1 • PQ mode 2

No.	Parameter	Description	Unit	Default Value	Value Range
4	Auto start upon grid recovery	Specifies whether to allow the SUN2000 to automatically start after the power grid recovers.	N/A	Enable	<ul style="list-style-type: none"> • Disable • Enable
5	Grid connection duration after power grid recovery	Specifies the waiting time for SUN2000 restart after the power grid recovers.	s	60	[0, 900]
6	Grid reconnection voltage upper limit	The standards of certain countries and regions require that the SUN2000 must not export power to the power grid again when the grid voltage exceeds the value of Grid reconnection voltage upper limit after the SUN2000 shuts down due to a fault.	V	1.1 x Vn	[1 x Vn, 1.36 x Vn]
7	Grid reconnection voltage lower limit	The standards of certain countries and regions require that the SUN2000 must not export power to the power grid again when the grid voltage is below the value of Grid reconnection voltage lower limit after the SUN2000 shuts down due to a fault.	V	0.95 x Vn	[0.45 x Vn, 0.95 x Vn]
8	Grid reconnection frequency upper limit	The standards of certain countries and regions require that the SUN2000 must not export power to the power grid again when the grid frequency exceeds the value of Grid reconnection frequency upper limit after the SUN2000 shuts down due to a fault.	Hz	1.004 x Fn	[1 x Fn, 1.12 x Fn]
9	Grid reconnection frequency lower limit	The standards of certain countries and regions require that the SUN2000 must not export power to the power grid again when the grid frequency is below the value of Grid reconnection frequency lower limit after the SUN2000 shuts down due to a fault.	Hz	0.95 x Fn	[0.85 x Fn, 1 x Fn]

No.	Parameter	Description	Unit	Default Value	Value Range
10	Reactive power compensation (cosφ-P) trigger voltage	Specifies the voltage threshold for triggering reactive power compensation based on the cosφ-P curve.	%	105	[100, 110]
11	Reactive power compensation (cosφ-P) exit voltage	Specifies the voltage threshold for exiting reactive power compensation based on the cosφ-P curve.	%	98	[90, 100]

7.2.2.2 Setting Protection Parameters

Procedure

Step 1 Choose **Function Menu > Settings > Protection Parameters** to access the settings screen.

Figure 7-6 Protection parameters (special user)



----End

Parameter List



NOTE

Vn represents the rated voltage and Fn represents the rated frequency.

No.	Parameter	Description	Unit	Default Value	Value Range
1	Unbalance voltage protection	Specifies the SUN2000 protection threshold in the case of unbalanced power grid voltage.	%	50.0	[0.0, 50.0]
2	Phase angle offset protection	The standards of certain countries and regions require that the SUN2000 needs to be protected when the three-phase angle offset of the power grid exceeds a certain value.	N/A	Disable	<ul style="list-style-type: none"> • Disable • Enable
3	10 minute OV protection	Specifies the 10-minute overvoltage protection threshold.	V	1.2 x Vn	[1 x Vn, 1.4 x Vn]
4	10 minute OV protection time	Specifies the 10-minute overvoltage protection duration.	ms	200	[50, 7200000]
5	Level-1 OV protection	Specifies the level-1 overvoltage protection threshold.	V	1.1×Vn	[1 x Vn, 1.4 x Vn]
6	Level-1 OV protection time	Specifies the level-1 overvoltage protection duration.	ms	2000	[50, 7200000]
7	Level-2 OV protection	Specifies the level-2 overvoltage protection threshold.	V	1.35 x Vn	[1 x Vn, 1.4 x Vn]
8	Level-2 OV protection time	Specifies the level-2 overvoltage protection duration.	ms	500	[50, 7200000]
9	Level-1 UV protection	Specifies the level-1 undervoltage protection threshold.	V	0.85×Vn	[0.15×Vn, 1×Vn]
10	Level-1 UV protection time	Specifies the level-1 undervoltage protection duration.	ms	2000	[50, 7200000]
11	Level-2 UV protection	Specifies the level-2 undervoltage protection threshold.	V	0.50 x Vn	[0.15×Vn, 1×Vn]
12	Level-2 UV protection time	Specifies the level-2 undervoltage protection duration.	ms	100	[50, 7200000]
13	Level-1 OF protection	Specifies the level-1 overfrequency protection threshold.	Hz	1.004 x Fn	[1 x Fn, 1.15 x Fn]

No.	Parameter	Description	Unit	Default Value	Value Range
14	Level-1 OF protection time	Specifies the level-1 overfrequency protection duration.	ms	120000	[50, 7200000]
15	Level-2 OF protection	Specifies the level-2 overfrequency protection threshold.	V	1.01 x Fn	[1 x Fn, 1.15 x Fn]
16	Level-2 OF protection time	Specifies the level-2 overfrequency protection duration.	ms	200	[50, 7200000]
17	Level-1 UF protection	Specifies the level-1 underfrequency protection threshold.	Hz	0.99 x Fn	[0.85 x Fn, 1 x Fn]
18	Level-1 UF protection time	Specifies the level-1 underfrequency protection duration.	ms	600000	[50, 7200000]
19	Level-2 UF protection	Specifies the level-2 underfrequency protection threshold.	Hz	0.96 x Fn	[0.85 x Fn, 1 x Fn]
20	Level-2 UF protection time	Specifies the level-2 underfrequency protection duration.	ms	200	[50, 7200000]

7.2.2.3 Setting Feature Parameters

Procedure

Step 1 Choose **Function Menu > Settings > Feature Parameters** to access the settings screen.

Figure 7-7 Feature parameters (special user)

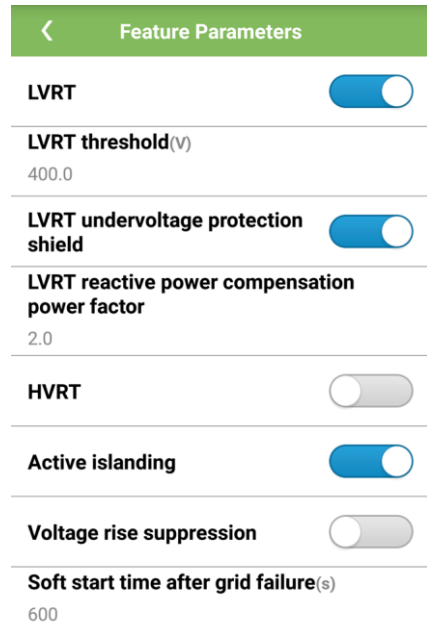

----End

Parameter List

No.	Parameter	Description	Unit	Default Value	Value Range	Remarks
1	LVRT	When the power grid voltage is abnormally low for a short time, the SUN2000 cannot disconnect from the power grid immediately and has to work for some time. This is called LVRT.	N/A	Enable	<ul style="list-style-type: none"> • Disable • Enable 	N/A
2	LVRT threshold	Specifies the threshold for triggering LVRT. The threshold settings should meet the local grid standard.	V	0.8 x Vn	[0.5 x Vn, 0.92 x Vn]	Vn represents the rated voltage.
3	LVRT undervoltage protection shield	Specifies whether to shield the undervoltage protection function during LVRT.	N/A	Enable	<ul style="list-style-type: none"> • Disable • Enable 	N/A

No.	Parameter	Description	Unit	Default Value	Value Range	Remarks
4	LVRT reactive power compensation power factor	During LVRT, the SUN2000 needs to generate reactive power to support the power grid. This parameter is used to set the reactive power generated by the SUN2000.	N/A	2	[0, 3]	For example, if you set LVRT reactive power compensation power factor to 2 , the reactive current generated by the SUN2000 is 20% of the rated current when the AC voltage drops by 10% during LVRT.
5	HVRT	When the power grid voltage is abnormally high for a short time, the SUN2000 cannot disconnect from the power grid immediately and has to work for some time. This is called high voltage ride-through (HVRT).	N/A	Disable	<ul style="list-style-type: none"> • Disable • Enable 	N/A
6	Active islanding	Specifies whether to enable the active islanding protection function.	N/A	Enable	<ul style="list-style-type: none"> • Disable • Enable 	N/A
7	Voltage rise suppression	The standards of certain countries and regions require that the SUN2000 should prevent the grid voltage from rising by delivering reactive power and decreasing active power when the output voltage exceeds a certain value.	N/A	Disable	<ul style="list-style-type: none"> • Disable • Enable 	N/A
8	Voltage rise suppression reactive adjustment point	The standards of certain countries and regions require that the SUN2000 must generate a certain amount of reactive power when the output voltage exceeds a certain value.	%	110	[100, 115]	<ul style="list-style-type: none"> • This parameter is displayed when Voltage rise suppression is set to Enable. • The value of Voltage rise suppression

No.	Parameter	Description	Unit	Default Value	Value Range	Remarks
9	Voltage rise suppression active derating point	The standards of certain countries and regions require that the active power of the SUN2000 be derated according to a certain gradient when the output voltage exceeds a certain value.	%	112.5	[100, 115]	active derating point must be greater than that of Voltage rise suppression reactive adjustment point .
10	Soft start time after grid failure	Specifies the time for the power to gradually increase when the SUN2000 restarts after the power grid recovers.	s	600	[20, 800]	N/A

7.2.2.4 Setting Power Adjustment Parameters

Procedure

Step 1 Choose **Function Menu** > **Settings** > **Power Adjustment** to access the settings screen.

Figure 7-8 Power adjustment parameters (special user)

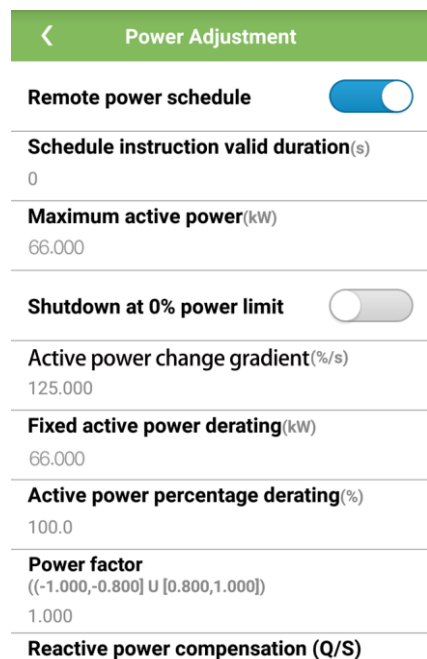

----End

Parameter List

Table 7-5 Parameter description

No.	Parameter	Description	Unit	Default Value	Value Range	Remarks
1	Remote power schedule	If this parameter is set to Enable , the SUN2000 responds to the remote power scheduling instruction. If this parameter is set to Disable , the SUN2000 does not respond to the remote power scheduling instruction.	N/A	Enable	<ul style="list-style-type: none"> • Disable • Enable 	N/A
2	Schedule instruction valid duration	Specifies the duration within which the scheduling instruction is valid.	s	0	[0, 86400]	If the value is less than 60 seconds, the scheduling instruction is valid permanently.
3	Maximum active power	Sets the upper threshold for the active power output to adapt to different market requirements.	kW	Pmax_limit	[0.1, Pmax_limit]	Pmax_limit: upper threshold for the active power output
4	Shutdown at 0% power limit	If this parameter is set to Enable , the SUN2000 shuts down after receiving the 0% power limit command. If this parameter is set to Disable , the SUN2000 does not shut down after receiving the 0% power limit command.	N/A	Disable	<ul style="list-style-type: none"> • Disable • Enable 	N/A
5	Active power change gradient	Adjusts the change speed of the SUN2000 active power.	%/s	125	[0.1, 1000]	Adjust the active power based on the percentage of the rated apparent power.
6	Fixed active power derating	Adjusts the active power output of the SUN2000 to a fixed value.	kW	Pmax_limit	[0, Pmax_limit]	Pmax_limit: upper threshold for the active power output

No.	Parameter	Description	Unit	Default Value	Value Range	Remarks
7	Active power percentage derating	Adjusts the active power output of the SUN2000 to a percentage.	%	100	[0, 100]	If this parameter is set to 100 , the SUN2000 delivers power output based on the maximum output power.
8	Power factor	Adjusts the SUN2000 power factor.	N/A	1.000	(-1.000, -0.800]U[0.800, 1.000]	N/A
9	Reactive power compensation (Q/S)	Adjusts the SUN2000 output reactive power.	N/A	0.000	(-1, 1]	N/A
10	Reactive power compensation at night (Q/S)	If Reactive power output at night is set to Enable , no PV input exists, and no remote scheduling instruction is delivered, the SUN2000 responds to this command.	N/A	0.000	(-1, 1]	N/A
11	Trigger frequency of over frequency derating	The standards of certain countries and regions require that the output active power of the SUN2000 be derated when the grid frequency exceeds a certain value.	Hz	1.004 x Fn	<ul style="list-style-type: none"> When the output frequency is 50 Hz, the value range is 45.00–55.00 Hz. When the output frequency is 60 Hz, the value range is 55.00–65.00 Hz. 	Fn represents the rated frequency.

No.	Parameter	Description	Unit	Default Value	Value Range	Remarks
12	Quit frequency of over frequency derating	Specifies the frequency threshold for exiting overfrequency derating.	Hz	1.001 x Fn	<ul style="list-style-type: none"> When the output frequency is 50 Hz, the value range is 45.00–55.00 Hz. When the output frequency is 60 Hz, the value range is 55.00–65.00 Hz. 	
13	Recovery gradient of over frequency derating	Specifies the power recovery gradient for overfrequency derating.	%/min	10	[5, 20]	N/A

8 Maintenance

8.1 Routine Maintenance

To ensure that the SUN2000 can operate properly for a long term, you are advised to perform routine maintenance on it as described in this chapter.

CAUTION

- Before cleaning the system and maintaining the cable connections and grounding reliability, power off the system (see [6.4 Powering Off the System](#) for details) and ensure that the two DC switches on the SUN2000 are OFF.
- If you need to open the maintenance compartment door on rainy or snowy days, take protective measures to prevent rain and snow entering the maintenance compartment. If it is impossible to take protective measures, do not open the maintenance compartment door on rainy or snowy days.

Table 8-1 Maintenance checklist

Item	Check Method	Maintenance Frequency
System cleanliness	Periodically check that the heat sinks are free from obstacles or dust.	Once every six to twelve months
System running status	<ul style="list-style-type: none">• Check that the SUN2000 is not damaged or deformed.• Check that the running sound of the SUN2000 is normal.• When the SUN2000 is running, check that all SUN2000 parameters are correctly set.	Once every six months

Item	Check Method	Maintenance Frequency
Electrical connections	<ul style="list-style-type: none"> • Check that cables are securely connected. • Check that cables are intact, in particular, the parts touching the metallic surface are not scratched. • Check that the unused COM, USB, and RESERVE ports are covered by watertight caps. 	The first inspection is six months after the initial commissioning. From then on, the interval can be six or twelve months.
Grounding reliability	Check that ground cables are securely connected.	The first inspection is six months after the initial commissioning. From then on, the interval can be six or twelve months.

8.2 Troubleshooting

Alarm severities are defined as follows:

- Major: The SUN2000 enters Shutdown mode and stops exporting power to the power grid due to a fault.
- Minor: Some components are faulty but the SUN2000 can still export power to the power grid.
- Warning: The SUN2000 output power decreases due to external factors.

Table 8-2 Common alarms and troubleshooting measures

Alarm ID	Alarm Name	Alarm Severity	Cause	Measures
2001	High String Input Voltage	Major	<p>The PV array is incorrectly configured. Excessive PV modules are connected in series to the PV string, and hence the PV string open-circuit voltage exceeds the maximum operating voltage of the SUN2000.</p> <ul style="list-style-type: none"> • Cause ID 1 corresponds to PV strings 1 and 2. • Cause ID 2 corresponds to PV strings 3 and 4. • Cause ID 3 corresponds to PV strings 5 and 6. • Cause ID 4 corresponds to PV strings 7 and 8. • Cause ID 5 corresponds to PV strings 9 and 10. • Cause ID 6 corresponds to PV strings 11 and 12. 	<p>Reduce the number of PV modules connected in series to the PV string until the PV string open-circuit voltage is less than or equal to the maximum operating voltage of the SUN2000. After the PV array configuration is corrected, the alarm stops.</p>
2011	String Reverse Connection	Major	<p>The PV string is reversely connected. Cause IDs 1 to 12 respectively correspond to PV strings 1 to 12.</p>	<p>Check whether the PV string is reversely connected to the SUN2000. If yes, wait until the solar irradiance declines at night and the PV string current reduces to below 0.5 A. Then, turn off the two DC switches and correct the PV string connection.</p>
2012	String Current Backfeed	Warning	<ol style="list-style-type: none"> 1. Only a few PV modules are connected in series to the PV string, and hence the end voltage is lower than that of other PV strings. 2. The PV string is shaded. <p>Cause IDs 1 to 12 respectively correspond to PV strings 1 to 12.</p>	<ol style="list-style-type: none"> 1. Check whether the number of PV modules connected in series to this PV string is less than the number of PV modules connected in series to the other PV strings. If yes, connect more PV modules in series to this PV string. 2. Check the open-circuit voltage of the PV string. 3. Check that the PV string is not shaded.

Alarm ID	Alarm Name	Alarm Severity	Cause	Measures
2013	Abnormal String Power	Warning	<ol style="list-style-type: none"> The PV string has been shaded for a long time. The PV string deteriorates abnormally. <p>Cause IDs 1 to 12 respectively correspond to PV strings 1 to 12.</p>	<ol style="list-style-type: none"> Check whether the current of the abnormal PV string is lower than the current of other PV strings. If yes, check that the abnormal PV string is not shaded and the actual number of PV strings is the same as the configured number. If the abnormal PV string is clean and not shaded, check whether the PV string is damaged.
2031	Phase Wire Short-Circuited to PE	Major	The impedance of the output phase wire to PE is low or the output phase wire is short-circuited to PE.	Check the impedance of the output phase wire to PE, locate the position with lower impedance, and rectify the fault.
2032	Grid Loss	Major	<ol style="list-style-type: none"> The power grid experiences an outage. The AC circuit is disconnected or AC switch is off. 	<ol style="list-style-type: none"> The alarm disappears automatically after the power grid recovers. Check that the AC power cable is connected and that the AC switch is ON.
2033	Grid Undervoltage	Major	The grid voltage is below the lower threshold or the low voltage duration has lasted for more than the value specified by LVRT.	<ol style="list-style-type: none"> If the alarm occurs accidentally, the power grid may be abnormal temporarily. The SUN2000 automatically recovers after detecting that the power grid becomes normal. If the alarm occurs frequently, check whether the power grid voltage is within the acceptable range. If no, contact the local power operator. If yes, modify the power grid undervoltage protection threshold with the consent of the local power operator. If the fault persists for a long time, check the AC circuit breaker and AC output power cable.

Alarm ID	Alarm Name	Alarm Severity	Cause	Measures
2034	Grid Overvoltage	Major	The grid voltage exceeds the higher threshold or the high voltage duration has lasted for more than the value specified by HVRT.	<ol style="list-style-type: none"> 1. Check whether the grid connection voltage exceeds the upper threshold. If yes, contact the local power operator. 2. If you have confirmed that the grid connection voltage exceeds the upper threshold and obtained the consent of the local power operator, modify the overvoltage protection threshold. 3. Check that the peak grid voltage does not exceed the upper threshold.
2035	Grid Voltage Imbalance	Major	The difference between grid phase voltages exceeds the upper threshold.	<ol style="list-style-type: none"> 1. Check that the grid voltage is within the normal range. 2. Check the connection of the AC output power cable. If the cable connection is proper but the alarm occurs frequently and affects the power production of the PV plant, contact the local power operator.
2036	Grid Overfrequency	Major	Power grid exception: The actual grid frequency is higher than the requirement of the local power grid standard.	<ol style="list-style-type: none"> 1. If the alarm occurs accidentally, the power grid may be abnormal temporarily. The SUN2000 automatically recovers after detecting that the power grid becomes normal. 2. If the alarm occurs frequently, check whether the grid frequency is within the acceptable range. If no, contact the local power operator. If yes, modify the power grid overfrequency protection threshold with the consent of the local power operator.

Alarm ID	Alarm Name	Alarm Severity	Cause	Measures
2037	Grid Underfrequency	Major	Power grid exception: The actual power grid frequency is lower than the standard requirement for the local power grid.	<ol style="list-style-type: none"> 1. If the alarm occurs accidentally, the power grid may be abnormal temporarily. The SUN2000 automatically recovers after detecting that the power grid becomes normal. 2. If the alarm occurs frequently, check whether the grid frequency is within the acceptable range. If no, contact the local power operator. If yes, modify the power grid underfrequency protection threshold with the consent of the local power operator.
2038	Unstable Grid Frequency	Major	Power grid exception: The actual grid frequency change rate does not comply with the local power grid standard.	<ol style="list-style-type: none"> 1. If the alarm occurs accidentally, the power grid may be abnormal temporarily. The SUN2000 automatically recovers after detecting that the power grid becomes normal. 2. If the alarm occurs frequently, check whether the grid frequency is within the acceptable range. If no, contact the local power operator.
2039	Output Overcurrent	Major	The power grid voltage drops dramatically or the power grid is short-circuited. As a result, the inverter transient output current exceeds the upper threshold and therefore the inverter protection is triggered.	<ol style="list-style-type: none"> 1. The inverter detects its external working conditions in real time. After the fault is rectified, the inverter automatically recovers. 2. If the alarm occurs frequently and affects the power production of the PV plant, check whether the output is short-circuited. If the fault persists, contact Huawei technical support.
2040	Output DC Component Overhigh	Major	The DC component of the SUN2000 output current exceeds the specified upper threshold.	<ol style="list-style-type: none"> 1. If the exception is caused by an external fault, the SUN2000 automatically recovers after the fault is rectified. 2. If the alarm occurs frequently and affects the power production of the PV plant, contact Huawei technical support.

Alarm ID	Alarm Name	Alarm Severity	Cause	Measures
2051	Abnormal Residual Current	Major	The insulation impedance of the input side to PE decreases when the SUN2000 is operating.	<ol style="list-style-type: none"> 1. If the alarm occurs accidentally, the external power cable may be abnormal temporarily. The SUN2000 automatically recovers after the fault is rectified. 2. If the alarm occurs frequently or persists, check that the impedance between the PV string and ground is not below the lower threshold.
2061	Abnormal Grounding	Major	<ol style="list-style-type: none"> 1. The PE cable for the SUN2000 is not connected. 2. The SUN2000 output side does not connect to an isolation transformer when the PV string output is grounded. 	<ol style="list-style-type: none"> 1. Check that the PE cable for the SUN2000 is connected properly. 2. If the PV string output is grounded, check that the SUN2000 output side connects to an isolation transformer.
2062	Low Insulation Resistance	Major	<ol style="list-style-type: none"> 1. The PV string is short-circuited to PE. 2. The PV string has been in a moist environment for a long time and the power cable is not well insulated to ground. 	<ol style="list-style-type: none"> 1. Check the impedance between the PV string and the PE cable. If a short circuit occurs, rectify the fault. 2. Check that the PE cable for the SUN2000 is correctly connected. 3. If you are sure that the impedance is less than the default value in a cloudy or rainy environment, reset Insulation resistance protection.
2063	Cabinet Overtemperature	Major	<ol style="list-style-type: none"> 1. The SUN2000 is installed in a place with poor ventilation. 2. The ambient temperature exceeds the upper threshold. 3. The SUN2000 is not working properly. 	<ol style="list-style-type: none"> 1. Check the ventilation and ambient temperature at the SUN2000 installation position. If the ventilation is poor or the ambient temperature exceeds the upper threshold, improve the ventilation and heat dissipation. 2. If the ventilation and ambient temperature both meet requirements, contact Huawei technical support.
2064	Device Fault	Major	An unrecoverable fault occurs on a circuit inside the SUN2000.	Turn off the AC output switch and DC input switch, and then turn them on after 15 minutes. If the fault persists, contact Huawei technical support.

Alarm ID	Alarm Name	Alarm Severity	Cause	Measures
2065	Upgrade Failed	Minor	The upgrade ends abnormally.	<ol style="list-style-type: none"> 1. Perform an upgrade again. 2. If the upgrade fails several times, contact your dealer.
2066	License Expired	Warning	<ol style="list-style-type: none"> 1. The privilege certificate has entered the grace period. 2. The privilege feature will be invalid soon. 	<ol style="list-style-type: none"> 1. Apply for a new certificate. 2. Load the new certificate.
61440	Faulty Monitoring Unit	Minor	<ol style="list-style-type: none"> 1. The flash memory is insufficient. 2. The flash memory has bad sectors. 	Turn off the AC output switch and DC input switch, and then turn them on after 15 minutes. If the fault persists, replace the monitoring board or contact Huawei technical support.
2085	Built-in PID Operation Abnormal	Minor	<ol style="list-style-type: none"> 1. The output resistance of PV arrays to ground is low. 2. The system insulation resistance is low. 	<ul style="list-style-type: none"> • Cause ID = 1 <ol style="list-style-type: none"> 1. Turn off the AC output switch and then the DC input switch. After 15 minutes, turn on the AC output switch and then the DC input switch. 2. If the fault persists, contact your supplier/Huawei technical support. • Cause ID = 2 <ol style="list-style-type: none"> 1. Check the output resistance of PV arrays to ground. If there is a short circuit or lack of insulation, rectify it. 2. If the fault persists, contact your supplier/Huawei technical support.



NOTE

Contact Huawei technical support if all failure analysis procedures listed above are completed and the fault still exists.

9 Handling the Inverter

9.1 Removing the SUN2000

NOTICE

Before removing the SUN2000, disconnect both the AC and DC power supplies. For details about the power-off process, see [6.4 Powering Off the System](#). After powering off the SUN2000, wait at least 15 minutes before performing operations on it.

To remove the SUN2000, perform the following steps:

1. Disconnect all cables from the SUN2000, including RS485 communications cables, DC input power cables, AC output power cables, and PE cables.
2. Remove the SUN2000 from the mounting bracket.
3. Remove the mounting bracket.

9.2 Packing the SUN2000

- If the original packing materials are available, put the SUN2000 inside them and then seal them by using adhesive tape.
- If the original packing materials are not available, put the SUN2000 inside a suitable cardboard box and seal it properly.

9.3 Disposing of the SUN2000

If the SUN2000 service life expires, dispose of it according to the local disposal rules for electrical equipment waste.

10 Technical Specifications

Efficiency

Item	SUN2000-50KTL-M0	SUN2000-60KTL-M0
Maximum efficiency	98.70%	
Chinese efficiency	98.30%	
European efficiency	98.50%	

Input

Item	SUN2000-50KTL-M0	SUN2000-60KTL-M0
Maximum input power	56,200 W	67,400 W
Maximum input voltage	1100 V	
Maximum input current (per MPPT)	22 A	
Maximum input current (per string)	18 A	
Maximum short-circuit current (per MPPT)	30 A	
Maximum SUN2000 backfeed current to the PV array	0 A	
Minimum startup voltage	200 V	
Operating voltage range	200–1000 V	
Full power MPPT voltage range	520–800 V	520–800 V
Rated input voltage	600 V@380 V/400 V, 620 V@415 V	600 V

Item	SUN2000-50KTL-M0	SUN2000-60KTL-M0
Number of inputs	12	
Number of MPP trackers	6	

Output

Item	SUN2000-50KTL-M0	SUN2000-60KTL-M0
Rated active power	50 kW	60 kW
Maximum apparent power	55 kVA	66 kVA
Maximum active power	55kW	66 kW
Rated output voltage ^a	220V/380V, 230V/400V, 240V/415V, 3W+(N ^b)+PE	
Rated output current	76 A@380 V, 72.2 A@400 V, 69.6 A@415 V	91.2 A (380 V), 86.7 A (400 V)
Adapted grid frequency	50 Hz/60 Hz	
Maximum output current	83.6 A@380 V, 79.4 A@400 V, 76.6 A@415 V	100 A (380 V), 95.3 A (400 V)
Power factor	0.8 leading ... 0.8 lagging	
Maximum total harmonic distortion (rated power)	< 3%	
<p>Note a: The rated output voltage of the SUN2000 is determined by Grid code, which can be set on the SUN2000 app, SmartLogger, or NetEco.</p> <p>Note b: Choose whether to connect the neutral wire to the SUN2000 based on the application scenario. When it is used in the scenarios without neutral wires, set Output mode to Three-phase, three-wire. When it is used in the scenarios with neutral wires, set Output mode to Three-phase, four-wire.</p>		

Protection

Item	SUN2000-50KTL-M0	SUN2000-60KTL-M0
Input DC switch	Supported	
Anti-islanding protection	Supported	
Output overcurrent protection	Supported	
Input reverse polarity protection	Supported	
PV string fault detection	Supported	

Item	SUN2000-50KTL-M0	SUN2000-60KTL-M0
DC surge protection	Type II	
AC surge protection	Type II	
Insulation resistance detection	Supported	
Residual current monitoring unit (RCMU)	Supported	
Overtoltage category	PV II/AC III	
Built-in PID repair	Not supported	Optional
<p>Note c: When the SUN2000 is disconnected from the grid and stops working, the built-in PID can achieve the PV– positive offset of the PV module. (PV– positive offset refers to raising the voltage between PV– and the ground to above 0 V through voltage compensation.) When designing a power plant, confirm with the PV module manufacturer that the anti-PID voltage compensation direction of the PV module is the same as the direction of the PV– positive offset. Otherwise, PV modules may be damaged.</p>		

⚠ CAUTION

For the SUN2000 that supports built-in PID repair, when **Built-in PID running mode** is set to **Repair**, there is repair voltage between PV modules and the ground at night. If you need to maintain PV modules at night, power off the SUN2000 to avoid electric shocks.

Display and Communication

Item	SUN2000-50KTL-M0	SUN2000-60KTL-M0
Display	LED, Bluetooth module+app, USB data cable+app	
Communication networking mode	PLC/RS485/RS485+4G ^d	
<p>Note d: 4G networking is supported in China only.</p>		

Common Parameters

Item	SUN2000-50KTL-M0	SUN2000-60KTL-M0
Dimensions (W x H x D)	1075 mm x 555 mm x 300 mm	
Net weight	74kg±1kg	
Operating temperature	–25°C to +60°C	
Cooling mode	Natural convection	
Maximum operating altitude	4000 m	

Item	SUN2000-50KTL-M0	SUN2000-60KTL-M0
Humidity	0%–100% RH	
Input terminal	Amphenol Helios H4	
Output terminal	Cable gland+OT terminal	
Ingress Protection Rating	IP65	
Topology	Transformerless	

A Acronyms and Abbreviations

C

CCO central controller

H

HVRT high voltage ride-through

L

LED light emitting diode

LVRT low voltage ride-through

M

MPP maximum power point

MPPT maximum power point tracking

P

PID potential induced degradation

PV photovoltaic

R

RCD residual current device

W

WEEE

waste electrical and
electronic equipment