

PHOTOCELL LIGHTING CONTROL WITH INTERNAL SENSOR

- Threshold adjustable from 2 to 200 LUX
- The product is supplied pre-set at 10 LUX

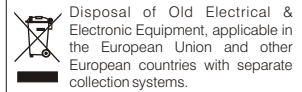



PE - DEICNN008 02/06

ENGLISH

1 - TECHNICAL DATA

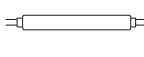
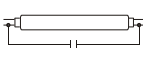
Supply voltage: 230V~ 50 ÷ 60 Hz
 Type of output: Relay with NA single-pole polarized contact, 16A - 3AX / 230V~
 Example of maximum operating power: 3500 W / 230V~ cosφ=1

 2300 W (23 x 100 W)	 700 W (12 x 58 W)	 290 W (5 x 58 W 35 μF)	 105 W (7 x 15 W)
--	--	---	---

Maximum wire section at terminals: 1,5 ÷ 2,5 mm²
 Protection degree: IP 65
 Activation threshold: 2 ÷ 200 LUX adjustable
 Switch on/switch off delay: 25 seconds approx.
 Operating temperature limits: -30 °C ÷ +60 °C
 Storing temperature limits: -30 °C ÷ +65 °C
 Installation: For external use pole or wall mounting
 Reference standard for CE mark: LVD EN60669-2-1
 EMC EN60669-2-1

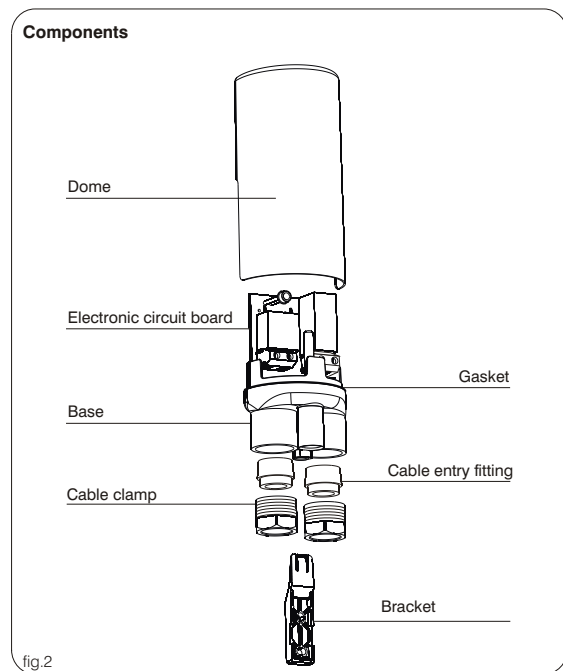
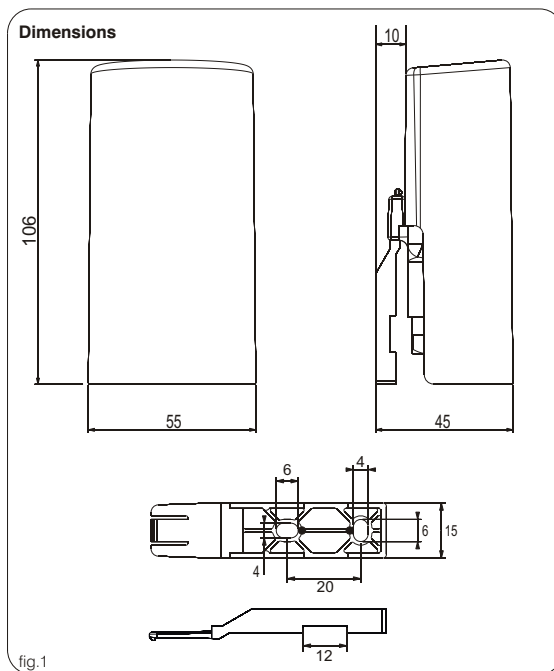

2 - INSTALLATION

Important: installation and electrical connections of devices and appliances must be carried out by skilled persons and in compliance with current regulations.

The manufacturer declines any liability in connection with the use of products subject to special environmental and/or installation standards.

Note for installer

Ensure in advance that all cables (especially power) are properly routed and ducted in accordance with installation standards.

Installation of switch

- Device intended for external installation:
 - pole mounting** fixing the bracket vertically with a tie (not included) inserted through the provided recess (fig. 9);
 - wall mounting** fixing the bracket vertically with 2 screws (not included) into the provided holes (fig. 10);
- remove the dome from the base;
- mount the base of the photocell switch on the bracket;
- disconnect the mains supply;
- slip the cable clamp nuts over the cables (maximum external diameter of cable 7 ÷ 11mm);
- pierce the web of the rubber grommets and slip the grommets over the cables (fig. 3);
- insert the ends of the cables into the base and make the electrical Connections;
- connect the 230V power supply conductors to the terminals:
 - L = live, N = neutral;
- connect the lamp as indicated in fig. 4 (options "A" or "B");
- locate the rubber grommets of the cable entry fittings in their seats;
- tighten the cable clamp nuts to ensure a hermetic seal.

Important: in cases where a single cable is routed to the switch, the cable entry not utilised must be sealed by inserting the rubber grommet (unpierced) tightening the cable clamp nut.

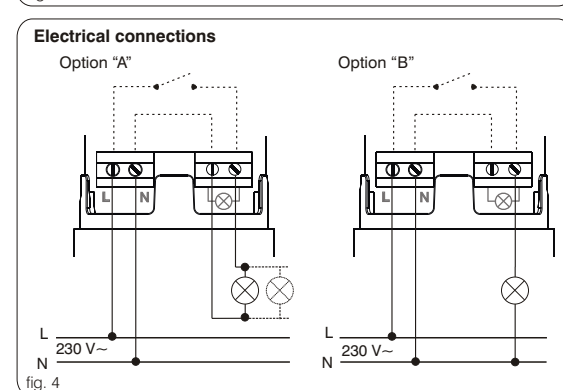
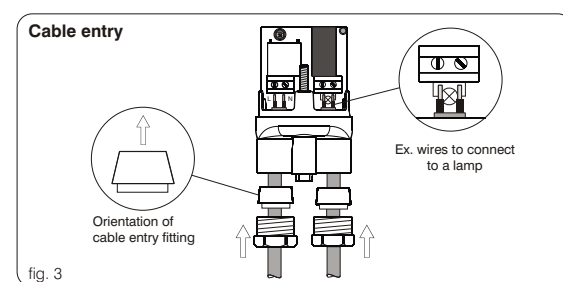

3 - FITTING THE DOME

- check the correct positioning of the gasket on the base
- position the dome (fig. 5) and press down until the captive screw is engaged.

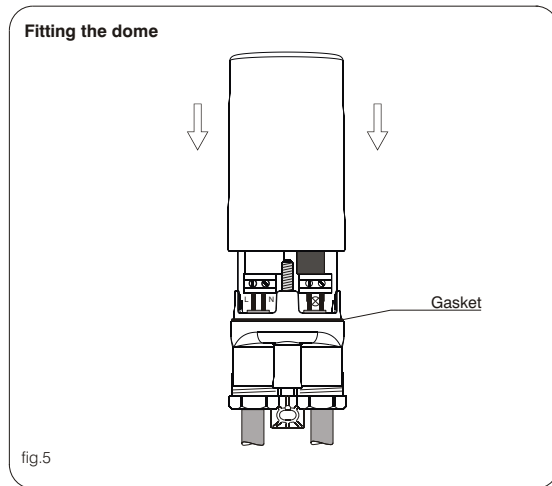

4 - CLOSING THE DEVICE

- Secure the dome by tightening the captive screw inserted through the bottom of the base. Tighten the screw until the dome presses on the gasket sufficiently to ensure a hermetic seal (fig. 6).

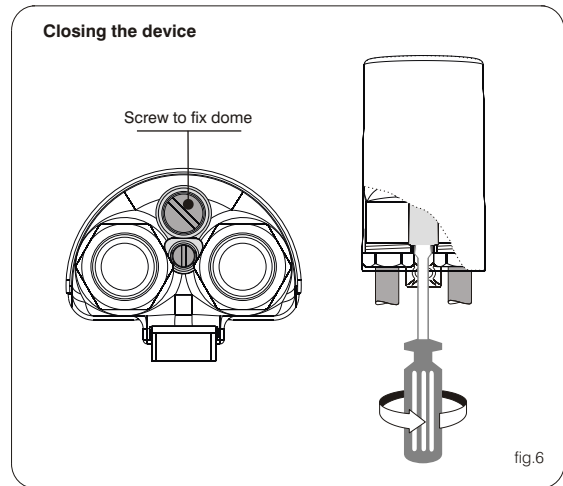

5 - ADJUSTABLE ACTIVATION THRESHOLD (LUX)

WARNING: in the case of particularly reactive loads (e.g. fluorescent or HID or electronic lamps, etc.) or with a $\cos\phi$ value lower than those indicated in the technical data, the relay could suffer damage. It is advisable in such instances to use a suitably rated external relay or solenoid switch.

IMPORTANT: the device is factory set to 10 Lux

- switch on the power supply
- make the threshold adjustment (from 2 to 200 LUX) by turning the trimmer (fig. 7); the LED will light up to indicate the activation status of the threshold.

N.B.: the relay operation for switching on or off will take place with a delay of approx. 25 sec.

6 - OPERATION

The photocell switch pilots the switching on and off of external lighting systems. The contact of the switch will close when the level of daylight falls below the set threshold and stay closed until the daylight returns above the threshold. For correct operation, the photocell switch must be installed in such a way that it will remain unaffected when the lamps to which it is connected are ignited or energized (see fig. 9 and fig. 10) or from any other source of light (shop signs, car lights, etc...).

7 - OPERATION TEST

To test the device during day time, make use for example the product carton box to shade the photocell switch (fig. 8).

Adjustable activation threshold

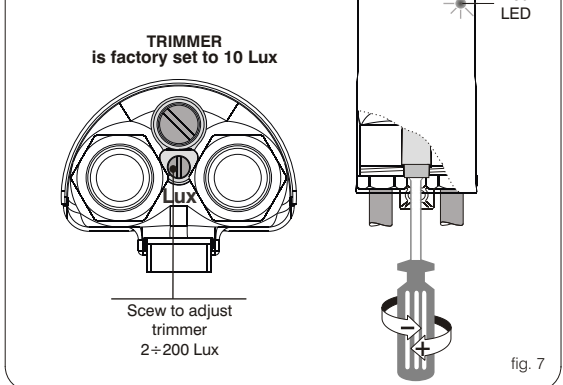

Operation test

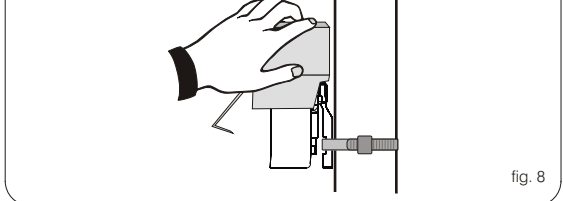

Example of installation on pole

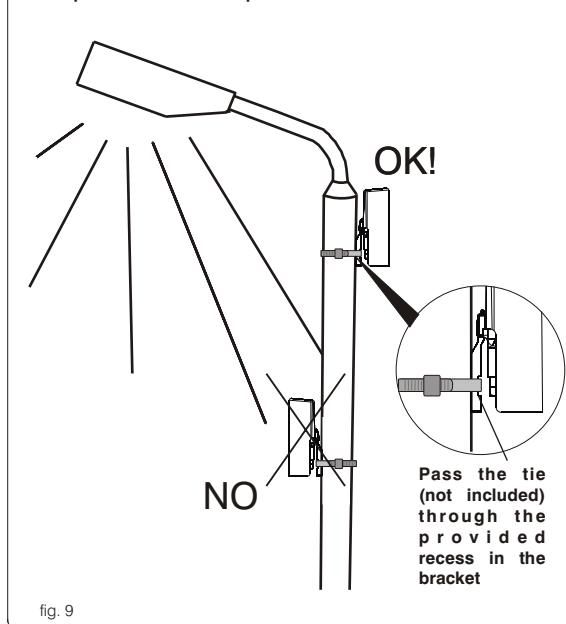

Example of wall mounting installation

