

TABLE OF CONTENT

1. Technical features	6
2. Code selection	6
3. Display, keyboard and icons	7
4. Quick access parameter setting	8
Keyboard lock:	8
Switch on and off	8
Setpoint setting	8
Fancoil operating mode	9
MODE button functionality	9
5. Date and time setting (Model TH-xxCSx1)	11
6. TIME ZONES operation and setting (Model TH-xxCSx1)	11
7. TIME ZONE duplication (Model TH-xxCSx1)	13
8. Manufacturer parameter setting (level 1 password)	14
9. Installer parameter setting (level 2 password)	16
10. Digital and analogue input logic	20
Digital inputs	20
Analogue inputs	21
11. Regulation sensor(s)	24
12. Automatic season changeover with water sensor (MO1=2 or 5)	24
13. Frost protection	24
14. Working setpoint, ECONOMY mode and HOLIDAY mode	25
15. Timer extension mode	27
16. Fancoil with EC motor (models TH-0xxSx1, TH-1xxSx1, TH-2xxSx1)	27
EC motor automatic speed control logic with on/off outputs	27
EC motor automatic speed control logic with 0..10 V modulating outputs	28
17. Fancoil with 3 speed on-off motor (models TH-2xxSx1, TH-3xxSx1, TH-4xxSx1)	29
3 speed on-off motor speed control logic with on/off outputs	29
3 speed on-off motor speed control logic with 0...10V modulating outputs	29
18. Manual speeds and ventilation maintenance with no control	30
19. Fan boost	30
20. Minimum thermostat	30
21. Destratification cycle	31
22. Dirty filter	31
23. Window contact	31
24. Summertime changeover	31
25. Sensor AI3 used as input 0...10V	31
26. Outputs forced via Modbus	32
27. Alarms	33
28. Resetting the default parameters	35

29. Control with EC motor (Model TH-0xxSx1).....	36
HEATING mode (M01=0)	36
<i>Wiring diagram</i>	36
HEATING/HEATING mode (M01=1)	37
<i>Wiring diagram</i>	37
2 PIPE HEATING/COOLING mode with AUTOMATIC SEASON CHANGEOVER (M01=2):	38
2 PIPE HEATING/COOLING mode with SEASON CHANGEOVER by CONTACT (M01=3):	38
2 PIPE HEATING/COOLING with SEASON CHANGEOVER by PARAMETER (M01=4):	38
<i>Wiring diagram</i>	39
2 PIPE HEATING/COOLING + ELECTRIC RESISTANCE mode with AUTOMATIC SEASON CHANGEOVER (M01=5):	40
2 PIPE HEATING/COOLING + ELECTRIC RESISTANCE mode with SEASON CHANGEOVER by CONTACT (M01=6):	40
2 PIPE HEATING/COOLING + ELECTRIC RESISTANCE mode with SEASON CHANGEOVER by PARAMETER (M01=7):	41
<i>Wiring diagram</i>	43
4 PIPE HEATING/COOLING mode (M01=8)	44
<i>Wiring diagram</i>	44
4 PIPE HEATING/COOLING mode + ELECTRIC RESISTANCE (M01=9)	45
<i>Wiring diagram</i>	45
COOLING mode (M01=10)	46
<i>Wiring diagram</i>	46
COOLING/COOLING mode (M01=11)	47
<i>Wiring diagram</i>	47
30. Regulation (Model TH-1xxSx1).....	48
HEATING mode (M01=0)	48
<i>Wiring diagram</i>	48
HEATING/HEATING mode (M01=1)	49
<i>Wiring diagram</i>	49
2 PIPE HEATING/COOLING mode with AUTOMATIC SEASON CHANGEOVER (M01=2):	50
2 PIPE HEATING/COOLING mode with SEASON CHANGEOVER by CONTACT (M01=3):	50
2 PIPE HEATING/COOLING with SEASON CHANGEOVER by PARAMETER (M01=4):	50
<i>Wiring diagram</i>	51
2 PIPE HEATING/COOLING + ELECTRIC RESISTANCE mode with AUTOMATIC SEASON CHANGEOVER (M01=5):	52
2 PIPE HEATING/COOLING + ELECTRIC RESISTANCE mode with SEASON CHANGEOVER by CONTACT (M01=6):	52
2 PIPE HEATING/COOLING + ELECTRIC RESISTANCE mode with SEASON CHANGEOVER by PARAMETER (M01=7):	52
<i>Wiring diagram</i>	54
4 PIPE HEATING/COOLING mode (M01=8)	55
<i>Wiring diagram</i>	56
4 PIPE HEATING/COOLING mode + ELECTRIC RESISTANCE (M01=9)	57
<i>Wiring diagram</i>	58
COOLING mode (M01=10)	59
<i>Wiring diagram</i>	59
COOLING/COOLING mode (M01=11)	60
<i>Wiring diagram</i>	60
31. Regulation with EC motor (Model TH-2xxSx1).....	61
HEATING mode (M01=0)	61
<i>Wiring diagram</i>	61
HEATING/HEATING mode (M01=1)	62
<i>Wiring diagram</i>	62
2 PIPE HEATING/COOLING mode with AUTOMATIC SEASON CHANGEOVER (M01=2):	63
2 PIPE HEATING/COOLING mode with SEASON CHANGEOVER by CONTACT (M01=3):	63

2 PIPE HEATING/COOLING with SEASON CHANGEOVER by PARAMETER (M01=4):	64
<i>Wiring diagram</i>	65
2 PIPE HEATING/COOLING + ELECTRIC RESISTANCE mode with AUTOMATIC SEASON CHANGEOVER (M01=5):	66
2 PIPE HEATING/COOLING + ELECTRIC RESISTANCE mode with SEASON CHANGEOVER by CONTACT (M01=6):	66
2 PIPE HEATING/COOLING + ELECTRIC RESISTANCE mode with SEASON CHANGEOVER by PARAMETER (M01=7):	67
<i>Wiring diagram</i>	69
4 PIPE HEATING/COOLING mode (M01=8)	70
<i>Wiring diagram</i>	70
4 PIPE HEATING/COOLING mode + ELECTRIC RESISTANCE (M01=9)	71
<i>Wiring diagram</i>	72
COOLING mode (M01=10)	73
<i>Wiring diagram</i>	73
COOLING/COOLING mode (M01=11)	74
<i>Wiring diagram</i>	74
32. Control with 3 speed ON/OFF motor (Model TH-2xxSx1).....	75
HEATING mode (M01=0)	75
<i>Wiring diagram</i>	75
2 PIPE HEATING/COOLING mode with AUTOMATIC SEASON CHANGEOVER (M01=2):	76
2 PIPE HEATING/COOLING mode with SEASON CHANGEOVER by CONTACT (M01=3):	76
2 PIPE HEATING/COOLING with SEASON CHANGEOVER by PARAMETER (M01=4):	76
<i>Wiring diagram</i>	78
COOLING mode (M01=10)	79
<i>Wiring diagram</i>	79
33. Regulation (Model TH-3xxSx1).....	80
HEATING mode (M01=0)	80
<i>Wiring diagram</i>	80
HEATING/HEATING mode (M01=1)	81
<i>Wiring diagram</i>	81
2 PIPE HEATING/COOLING mode with AUTOMATIC SEASON CHANGEOVER (M01=2):	82
2 PIPE HEATING/COOLING mode with SEASON CHANGEOVER by CONTACT (M01=3):	82
2 PIPE HEATING/COOLING with SEASON CHANGEOVER by PARAMETER (M01=4):	82
<i>Wiring diagram</i>	84
4 PIPE HEATING/COOLING mode (M01=8)	85
<i>Wiring diagram</i>	86
COOLING mode (M01=10)	87
<i>Wiring diagram</i>	87
COOLING/COOLING mode (M01=11)	88
<i>Wiring diagram</i>	88
34. Regulation (Model TH-4xxSx1).....	89
HEATING mode (M01=0)	89
<i>Wiring diagram</i>	90
HEATING/HEATING mode (M01=1)	91
<i>Wiring diagram</i>	91
2 PIPE HEATING/COOLING mode with AUTOMATIC SEASON CHANGEOVER (M01=2):	92
2 PIPE HEATING/COOLING mode with SEASON CHANGEOVER by CONTACT (M01=3):	92
2 PIPE HEATING/COOLING with SEASON CHANGEOVER by PARAMETER (M01=4):	92
<i>Wiring diagram</i>	94
2 PIPE HEATING/COOLING + ELECTRIC RESISTANCE mode with AUTOMATIC SEASON CHANGEOVER (M01=5):	95
2 PIPE HEATING/COOLING + ELECTRIC RESISTANCE mode with SEASON CHANGEOVER by CONTACT (M01=6):	95

2 PIPE HEATING/COOLING + ELECTRIC RESISTANCE mode with SEASON CHANGEOVER by PARAMETER (M01=7):	95
<i>Wiring diagram</i>	99
4 PIPE HEATING/COOLING mode (M01=8)	100
<i>Wiring diagram</i>	101
COOLING mode (M01=10)	102
<i>Wiring diagram</i>	102
COOLING/COOLING mode (M01=11)	103
<i>Wiring diagram</i>	103
35. USB connection.....	104
36. Jumper settings.....	104
37. Modbus (for versions TH-xMxSx1)	105
Default parameters reset via MODBUS	110
Clock setting via MODBUS	111
MODBUS communications alarm	111
MODBUS connection diagram	112
38. BACnet (for versions TH-xBxSx1)	113
BACnet connection diagram	113
BACnet protocol implementation conformance statement	114
<i>Product description</i>	114
<i>BACnet Standardized Device Profile (Annex L)</i>	114
<i>List of all BACnet Interoperability Building Blocks Supported (Annex K)</i>	114
<i>Segmentation Capability</i>	114
<i>Standard Object Types Supported</i>	115
<i>Data Link Layer Options</i>	116
<i>Device Address Binding</i>	116
<i>Networking Options</i>	116
<i>Network Security Options</i>	116
<i>Character Sets Supported</i>	116
BACnet signals	117
<i>Analogue inputs</i>	117
<i>Analogue values</i>	117
<i>Binary inputs</i>	118
<i>Binary values</i>	119
<i>Multistate values</i>	120
<i>Device</i>	121
39. Electrical connection	122
40. Dimensions	124
41. Installation instructions.....	124

TH room controller

1. Technical features

Power:	110...230 V AC ±10%, 50/60 Hz
Power consumption:	max 1.3W
Operating temperature:	0...50°C
Display:	backlit LCD display
Inputs:	2 potential free contacts 2 or 3 NTC10K sensors USB for configuration and software updates
Outputs:	3 analogue outputs 0...10V ($R_L > 10K$) depending on model 5 SPST relays, 250V AC, 3A (AC1) depending on model
Communications:	Modbus RTU or BACnet B-ASC depending on model
Temperature reading range:	-15...90°C
Dimensions:	128 x 80 x 55.5 mm
Installation:	3 module flush-mounted box
Protection class:	IP30, class 2
CE standard conformity:	EN 60730-1, EN 61000-6-3, EN 61000-6-1

2. Code selection

Room controller TH	-	x	x	x	S	x	1
Version:		0					
1 digital output + 3 analogue outputs + 3 analogue inputs		1					
2 digital outputs + 2 analogue outputs + 3 analogue inputs		2					
3 digital outputs + 1 analogue output + 3 analogue inputs		3					
3 digital outputs + 2 analogue outputs + 2 analogue inputs		4					
5 digital outputs + 0 analogue outputs + 3 analogue inputs							
Communications:					S		
Without bus					M		
Modbus					B		
Bacnet							
Clock:					S		
Without clock					C		
With clock							
Internal sensor:							T
Temperature							H
Temperature + humidity							

3. Display, keyboard and icons

	Display A	
	Display B	
	On/Off	
flashing	Timer extension on	
on	Clock setting	
ECO	Economy function on	
	General alarm	
	Communications alarm	
	Parameters menu	
HEAT COOL	Working season	
	Filter dirty alarm	
	Cooling on	
	Frost protection on	
	Heating on	
	Electric resistance on	
	Holiday mode	
	Fancoil speed	
OFF ON	Display C Time zone number with status	
Keyboard		
	On/Off, navigation and confirm key	
	Change setpoint, navigation and value entry keys	
	Speed type key and ESC in navigation	
	Manual season or occupation changeover key or operating mode (see <i>"MODE button functionality" page 9</i>)	

4. Quick access parameter setting

The controller provides the following functions with a simple button press:

- Switch on and off
- Setpoint setting
- Fancoil operating mode
- MODE button functionality

The **MODE** button can be assigned one quick access function and two normal access functions, depending on parameter I 44 (see “*MODE button functionality*” page 9)

I 44=0: season changeover (if it is local, for 2 pipe systems)

I 44=1: timer extension.

I 44=2: operating mode (without clock, with time program, holiday)

• Keyboard lock:

To lock the keyboard, press simultaneously buttons , script LK appears on display for one second. It is then not possible to access parameters if a key is pressed, script LK appears on display for one second.

To unlock the keyboard, simultaneously buttons , script NLK appears on display for one second.

• Switch on and off

Switching on and off can be done in two ways: with an external contact or manually. If one of the digital contacts is configured as “Remote On/Off” (M03=1 or M05=1) or one of the sensors is used as a digital input configured as “Remote On/Off” (M07=4 or M09=4 or M11=4), the device can be switched off remotely by positioning the contact appropriately.

On this case the display A shows OFF and the display B shows rem if keyboard is not locked or Lrem if keyboard is locked.

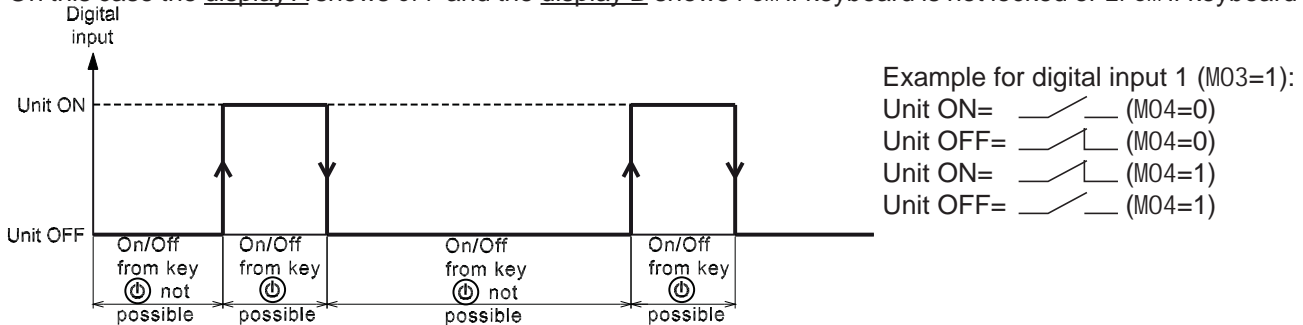

If the device is switched on by an external contact, it is however manually possible to switch on the device by pressing button  until ON or OFF is displayed.



When the device is switched off by an external contact, it is not possible to switch it on with button .

If the device is off, all outputs are deactivated except heating outputs in case of frost protection (see “*13. Frost protection*” page 24).



If external contact is not used as remote on/off, when unit is switched off manually, the display A shows OFF and the display B shows nothing if keyboard is not locked or Lc if keyboard is locked.



• Setpoint setting

Based on parameter I 52 value (CONFORT function), it is possible to modify directly the setpoint if I 52=0 or to set only a variation of $\pm 3^{\circ}\text{C}$ [$\pm 5^{\circ}\text{F}$] if I 52=1. On the last case, this offset is added to the setpoint I 07, I 08, I 09. This function is used when it is necessary that the setpoint is not directly accessible to users.

With I 52=0 pressing the  or  button, the value of actual setpoint is shown corresponding to setpoint I 07 (for heating mode M01=0..7) or I 08 (for cooling mode M01=2..7,10,11) or I 09 (for 4 pipes operating mode).



The “set” icon flashes. With the  or  button it is possible to modify the value; the new value is automatically saved.

With I 52=1 pressing the  or  button, the value of offset to apply to current setpoint is displayed.





The icon “°C” or “°F” is flashing based on actual unit. With the  or  button it is possible to modify the value; the new value is automatically saved.

To exit the setting menu, wait for 4 seconds or press button .

• **Fancoil operating mode**

Press button , the icon  flashes with the indication of the fancoil operating mode on display B.

Press button  one or more times to select the fan operating mode:

 A	AUT0=automatic control,
 M	SPE1=control with speed 1,
 M	SPE2=control with speed 2,
 M	SPE3=control with speed 3.

The value is automatically saved.



To exit the menu, wait for 4 seconds until display B stops flashing.

• **MODE button functionality**

To access quick functions of the MODE button:



If I 44=0 (local season selection setting for 2 pipe systems: M01=4 or M01=7)

Press button , the “HEAT” icon flashes (for heating) or “COOL” (for cooling) based on the actual setting and the same appears on display B.

Press button  to change the settings. The value is automatically saved. To exit the menu, wait for 4 seconds or press button .

If I 44=1 (timer extension setting)

The timer extension function extends operation with the base setpoint excluding the economy function and the “not occupied holiday” function for a time corresponding to parameter I 47.



Press button , the script **noOC** flashes on display B (to stop the timer extension if started) or script **OC** on display B and icon  flashes (to activate the timer extension)

Press button  to change the settings. The value is automatically saved.

To exit the menu, wait for 4 seconds or press button .

If I 44=2 (operating mode setting)



The operation mode setting selects the control mode, either excluding or including the time program (see “6. TIME ZONES operation and setting (Model TH-xxCSx1)” page 11), or in “not occupied holiday” mode (see “14. Working setpoint, Economy mode and holiday mode” page 25).

Press the button , the following script flashes:
nOrM on display B (for control without time zones) or
tiMB on display B and icon  (for control with time zones) or
HOLY on display B and icon  (for control in “not occupied holiday” mode).





Press button  one or more times to select the control mode. The value is automatically saved.



To exit the menu, wait for 4 seconds or press button .

To access the other functions of the MODE button:

- If the quick access mode of the **MODE** button is set to: Local season changeover (I 44=0), to access other functions, press buttons  and  together to enter the menu for changing the timer extension function and the operating mode:

Parameter	Description	Default	Min	Max
MOC	Timer extension noOC=timer extension off OC=timer extension on (this excludes the economy and not occupied holiday modes for the time set with parameter I 47)	noOC	noOC	OC
MOD	Operating mode nOrM=operation without time zones tiMb=operation with time zones HOLY=not occupied holiday mode	nOrM	nOrM, tiMb, HOLY	



Press  or  to select a parameter and key  to enter data entry mode, display B flashes with the current setting. Then press button  or  to change the value.

Press button  to save the settings, or button  to quit without saving





To exit the menu press button  again or wait for about 10 seconds.

If timer extension is on, icon  flashes for the time set in parameter I 47.

If the timer extension function is not active, the icon  is off.



- If the quick access mode of the **MODE** button is set to: Timer extension (I 44=1), to access other functions, press buttons  and  together to enter the menu for setting the timer extension and season changeover functions.

Parameter	Description	Default	Min	Max
MOD	Operating mode nOrM=operation without time zones tiMb=operation with time zones HOLY="not occupied holiday" mode	nOrM	nOrM, tiMb, HOLY	
SEA	Local season changeover (local season changeover setting for 2 pipe systems: MO1=4 or MO1=7) HEAT=heating mode Cool=cooling mode	HEAT	HEAT	Cool





Press  or  to select a parameter and key  to enter data entry mode, display B flashes with the current setting. Then press button  or  to change the value.



Press button  to save the settings, or button  to quit without saving

To exit the menu press button  again or wait for about 10 seconds.

- If the quick access mode of the **MODE** button is set to: Operating mode (I 44=2), to access other functions press buttons  and  together to enter the menu for setting the timer extension and season changeover functions.

Parameter	Description	Default	Min	Max
SEA	Local season changeover (local season changeover setting for 2 pipe systems: MO1=4 or MO1=7) HEAT=heating mode Cool=cooling mode	HEAT	HEAT	Cool
MOC	Timer extension noOC=timer extension off OC=timer extension on (this excludes the economy and not occupied holiday modes for the time set with parameter I 47)	noOC	noOC	OC

Press  or  to select a parameter and key  to enter data entry mode, display B flashes with the current setting. Then press button  or  to change the value.

Press button  to save the settings, or button  to quit without saving

To exit the menu press button  again or wait for about 10 seconds.

5. Date and time setting (Model TH-xxCSx1)

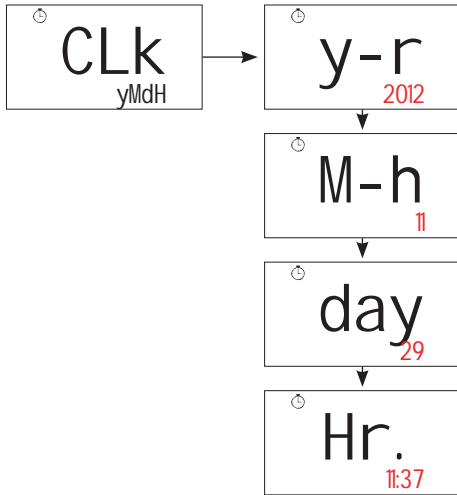

Press and together.
 CLK is displayed on display A and yMdh on display B.
 Press button to enter the date and hour setting menu

Parameter	Description	Min	Max
CLK	Date and time setting menu		
Y-r	Year	2012	2100
M-h	Month	1	12
day	Day	1	31
Hr.	Time (hour)	0	23
	Time (minutes)	0	59

Press button or to select a parameter to be modified and button to enter edit mode, display B flashes with the current value of the parameter.

Then press button or to change the value.

Press button to save the settings, or button to quit without saving.

To exit the menu press button again or wait for about 120 seconds.

Note: setting parameter I 46=1 for European zone or I 46=2 for USA zone, the device is able to automatically update summertime. If parameter I 46=0 (other zones), the summertime update is deactivated.

6. TIME ZONES operation and setting (Model TH-xxCSx1)

It is possible to use up to 4 time zones per day. Control is normal within an ON zone.

Outside ON zones, the controller works in economy mode (see [“14. Working setpoint, Economy mode and holiday mode” page 25](#)).

To work with a time zone, set the start time (ON) and the end time (OFF).

If the start time (ON) is equal or previous to the end time (OFF), the corresponding time zone is excluded.

If a time zone is included in another time zone, the first start time and the last end time will be used by the system.

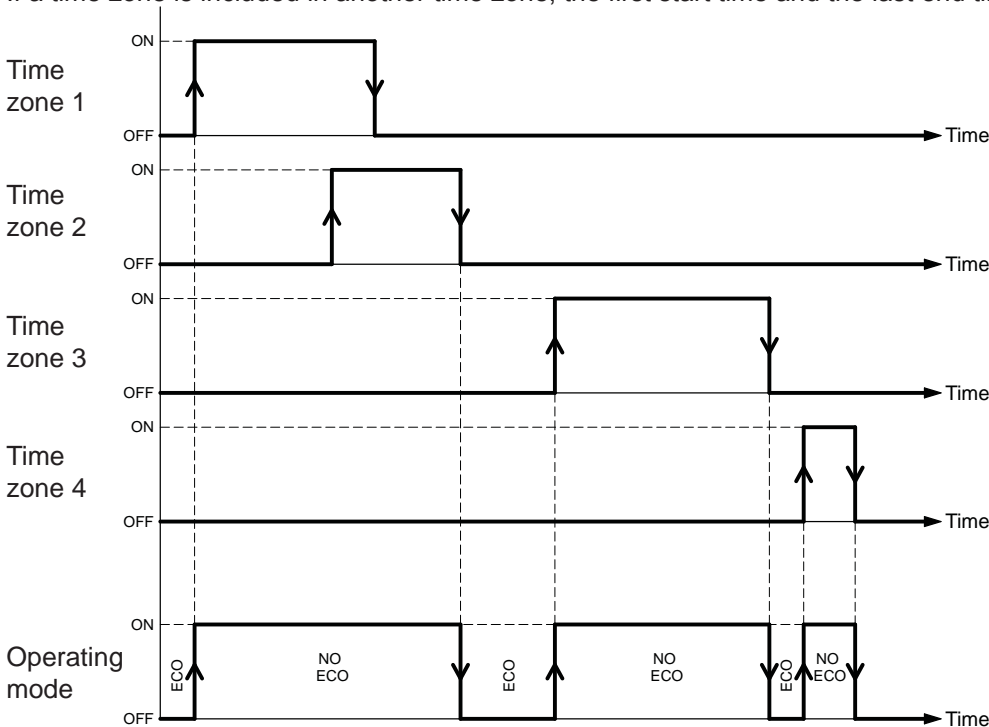

ECO=economy mode, **NO ECO**=normal mode (control with base setpoint)

To modify a time zone proceed as follows:

Press buttons and together, the main screen is displayed:



Press button , the following screen is displayed:



Press button , the screen with digit 1 flashing (corresponding to zone 1) is displayed;



Press button or to select the zone time to be modified.

Press button , the screen displays the day of the flashing time zone:



Press button or to select the day.

Press button , the screen displays the day, time zone number, and the starting hour (ON) of the flashing zone:



Then press button or to select the hour.

Press button , the zone start time stops flashing and is saved to memory, and the minutes of the selected time zone start flashing.

Press button or to select the minutes.

Press button , the minutes of the starting time of the time zone stop flashing and are saved to memory.

The screen for setting the end time of the time zone is displayed:



Then press button or to select the hour.

Press button , the zone start time stops flashing and is saved to memory, and the minutes of the end of the selected time zone start flashing.

Press button or to select the minutes.

Press button , the minutes of the ending time of the zone stop flashing and are saved to memory.

The screen for selecting the time zone day is displayed (flashing).

Press button to return to the zone selection menu:



Press button to return to the main menu or repeat the procedure to set another time zone.

Parameter	Description	Min	Max
WPR	Time zone settings menu		
Ti b	Zone selection	1	4
X	Day of week (X=Mon, Tue, Wed, Thu, Fri, Sat, Sun)	Mon	Sun
ON	Start of zone (hours)	0	23
	Start of zone (minutes)	0	59
OFF	End of zone (hours)	0	23
	End of zone (minutes)	0	59

7. TIME ZONE duplication (Model TH-xxCSx1)

It is possible to copy the settings of the time zones of a day on another single day or on 5 days from Monday to Friday or on 2 days from Saturday to Sunday.

To copy the zones from one day to another day follow the procedure described below.

Press buttons  and  together, the main screen is displayed:



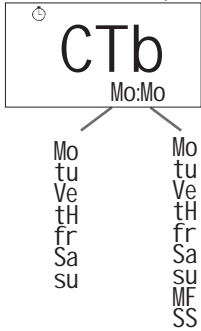

Press the button , the following screen is displayed:



Day to be copied: destination day

Press the button , the day to be copied flashes:

Select the day to copy with buttons  and .

Press the button , the destination day flashes on which the copy will be done:

If you set "MF" as the destination, the selected day will be copied to the days from Monday to Friday.

If you set "SS" as destination, the selected day will be copied to the days from Saturday to Sunday.

Press button  to proceed with duplication, or button  to cancel.

Parameter	Description	Min	Max
CTb	Copy time zones (Mo, tu, UE, tH, Fr, SA, Su)	Mo	SS
Mo	Monday		
tu	Tuesday		
Ve	Wednesday		
tH	Thursday		
fr	Friday		
Sa	Saturday		
su	Sunday		
MF	copy to Monday, Tuesday, Wednesday, Thursday and Friday		
SS	copy to Saturday and Sunday		

8. Manufacturer parameter setting (level 1 password)

The manufacturer parameters are password protected.

Press buttons  and  together to access the main menu. The following screen is displayed:

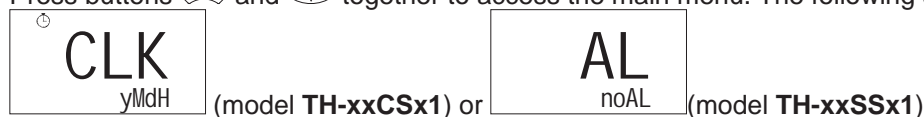

Press  or  to display the following screen:





Press button  and then button  until the value **22** is displayed.

Press button  to access level 1. The screen corresponding to the first level 1 parameter is displayed:



Use button  or  to scroll through the parameters.

To modify a parameter press button  and then buttons  or  to select its value.

Press button  to save the value or button  to quit parameter editing mode without saving.

To quit the menu, press button  again or wait for about 120 seconds.

Parameter	Description	Default	Min	Max
M01	Unit regulation type 0=Heating 1=Heating/heating (2 stage) 2=Heating/cooling with automatic season changeover (2 pipe) 3=Heating/cooling with season changeover via remote contact (2 pipe) 4=Heating/cooling with season changeover via parameter (2 pipe) 5=Heating + electric resistance/cooling, with automatic season changeover (2 pipe + electric resistance) 6=Heating + electric resistance/cooling, with season changeover via remote contact (2 pipe) 7=Heating + electric resistance/cooling, with season changeover via parameter (2 pipe) 8=Heating/Cooling (4 pipe) 9=Heating + electric resistance/cooling (4 pipe + electric resistance) 10=Cooling 11=Cooling/cooling (2 stage)	4	0	11
M02	Electric resistance stage Determines which heating stages use the electric resistance 0=no stage 1=stage 1 2=stage 2 3=stages 1 and 2 If M01=5, 6 or 7, M02 is automatically forced to 2. If M01=0, 1, 2, 3 or 4, and M02=0, the fancoil and stage 1 are switched off together without delay. If the electric resistance is present, and is deactivated, at least the delay set in parameter I 35 (see installer parameters table) must be expired before the fancoil can switch off.	0	0	3
M03	Digital input 1 function: 0=Remote season changeover (INPUT ON=winter, INPUT OFF=summer) 1=Remote On/Off 2=Not occupied holidays (INPUT ON=occupied) 3=Economy (INPUT ON=economy on) 4=Window contact (INPUT OFF=window open) 5=Alarm (INPUT ON=alarm present) 6=Minimum thermostat contact, fancoil water coil 7=Not used	7	0	7
M04	Digital input 1 contact logic: 0=Normally open (open=INPUT OFF, closed=INPUT ON) 1=Normally closed (closed=INPUT OFF, open=INPUT ON)	0	0	1
M05	Digital input 2 function: 0=Remote season changeover (INPUT ON=winter, INPUT OFF=summer) 1=Remote On/Off 2=Not occupied holidays (INPUT ON=occupied) 3=Economy (INPUT ON=economy on) 4=Window contact (INPUT OFF=window open) 5=Alarm (INPUT ON=alarm present) 6=Minimum thermostat contact, fancoil water coil 7=Not used	7	0	7
M06	Digital input 2 contact logic: 0=Normally open (open=INPUT OFF, closed=INPUT ON) 1=Normally closed (closed=INPUT OFF, open=INPUT ON)	0	0	1



Parameter	Description	Default	Min	Max
M07	Analogue input 1 function: 0=Remote regulation sensor 1=Water sensor for automatic season changeover 2=Minimum thermostat sensor (fancoil water coil) 3=Season changeover remote contact (INPUT ON=winter, INPUT OFF=summer) 4=Remote On/Off 5=Not occupied holidays (INPUT ON=occupied) 6=Economy (INPUT ON=economy on) 7=Window contact (INPUT OFF=window open) 8=Alarm (INPUT ON=alarm present) 9=Not used	9	0	9
M08	Analogue input 1 logic (only with M07=3...8): 0=Normally open (open=INPUT OFF, closed=INPUT ON) 1=Normally closed (closed=INPUT OFF, open=INPUT ON)	0	0	1
M09	Analogue input 2 function: 0=Remote regulation sensor 1=Water sensor for automatic season changeover 2=Minimum thermostat sensor (fancoil water coil) 3=Season changeover remote contact (INPUT ON=winter, INPUT OFF=summer) 4=Remote On/Off 5=Not occupied holidays (INPUT ON=occupied) 6=Economy (INPUT ON=economy on) 7=Window contact (INPUT OFF=window open) 8=Alarm (INPUT ON=alarm present) 9=Not used	9	0	9
M10	Analogue input 2 logic (only with M09=3...8): 0=Normally open (open=INPUT OFF, closed=INPUT ON) 1=Normally closed (closed=INPUT OFF, open=INPUT ON)	0	0	1
M11	Analogue input 3 function: 0=Remote regulation sensor 1=Water sensor for automatic season changeover 2=Minimum thermostat sensor (fancoil water coil) 3=Season changeover remote contact (INPUT ON=winter, INPUT OFF=summer) 4=Remote On/Off 5=Not occupied holidays (INPUT ON=occupied) 6=Economy (INPUT ON=economy on) 7=Window contact (INPUT OFF=window open) 8=Alarm (INPUT ON=alarm present) 9=Not used 10=Input 0...10V (Jumper JP1 must be set on 2-3 (0...10V))	9	0	10
M12	Analogue input 3 logic (only with M11=3...8): 0=Normally open (open=INPUT OFF, closed=INPUT ON) 1=Normally closed (closed=INPUT OFF, open=INPUT ON)	0	0	1
M13	Motor type 0=EC motor 1=3 speed on-off motor	0	0	1
M14	EC motor type 0=EC motor with auxiliary relay 1=standard EC motor	0	0	1
M15	Half season function enable Determines whether to enable the electric resistance for M01=5, 6 and 7 operation on models TH-0xxSx1, TH-1xxSx1, TH-2xxSx1 (M13=1), TH-4xxSx1 . 0=half season function not enabled 1=half season function enabled In cooling mode, you can use the electric resistance for heating if the temperature drops below the setpoint (see heating/cooling 2 pipe + electric resistance (M01=5, 6, 7) for the models indicated)	1	0	1

9. Installer parameter setting (level 2 password)

Installer parameters are password protected.

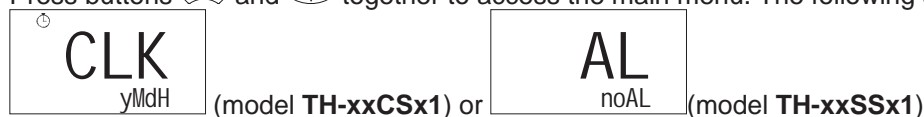
Press buttons  and  together to access the main menu. The following screen is displayed:



Press  or  to display the following screen:





Press button  and then button  until the value 11 is displayed.

Press button  to access level 1. The screen corresponding to the first level 1 parameter is displayed:



Use button  or  to scroll through the parameters.

To modify a parameter press button  and then buttons  or  to select its value.

Press button  to save the value or button  to quit parameter editing mode without saving.

To quit the menu, press button  again or wait for about 120 seconds.

Parameter	Description	Default	Min	Max
I 01	Internal temperature correction (K) (°C [°F]) The correction factor is added to the temperature reading of the internal sensor I 01	0	-5.0 [-9.0]	5.0 [9.0]
I 02	Measured internal humidity correction (%r.H) Correction parameter I 02 is added to the humidity reading (TH-xxxSH1 models only)	0	-10.0	10.0
I 03	External temperature correction AI1 (K) (°C [°F]) Correction factor I 03 is added to the external sensor reading AI1	0	-5.0 [-9.0]	5.0 [9.0]
I 04	External temperature correction AI2 (K) (°C [°F]) Correction factor I 04 is added to the external sensor reading AI2	0	-5.0 [-9.0]	5.0 [9.0]
I 05	External temperature correction AI3 (K) (°C [°F]) Correction factor I 05 is added to the external sensor reading AI3	0	-5.0 [-9.0]	5.0 [9.0]
I 06	Weighting (%) of external sensor AI1 in relation to the internal sensor (if M07=0) to create the regulation sensor. I 06=0 → only internal sensor used as regulation sensor I 06=100 → only sensor AI1 used as regulation sensor I 06=Y → sensor AI1 and internal sensor used together to create the regulation sensor, using the following formula $T_{reg} = [T_i (100 - Y) + (TA1 \times Y)] / 100$ The remote sensor AI1 must be set as remote regulation sensor, otherwise the parameter I 06 is not considered	0	0	100
I 07	Heating setpoint for regulation other than 4 pipe system (°C [°F])	20.0 [68]	I 11	I 10
I 08	Cooling setpoint for regulation other than 4 pipe system (°C [°F])	25.0 [77]	I 11	I 10
I 09	Setpoint for 4 pipe regulation (°C [°F])	21.0 [70]	I 11	I 10
I 10	Maximum regulation setpoint value (°C [°F]) Sets a maximum limit for setpoints I 07, I 08 and I 09	40.0 [104]	I 11	40.0 [104]
I 11	Minimum regulation setpoint value (°C [°F]) Sets a minimum limit for setpoints I 07, I 08 and I 09	6.0 [43]	6.0 [43]	I 10
I 12	Economy offset (K) (°C [°F]) In economy mode, the cooling setpoint is increased by I 12 In economy mode, the heating setpoint is decreased by I 12 Example: I 12= 3 BHS=20 - I 12= 17°C BCS=25 + I 12= 28°C	3.0 [5]	1.0 [2]	6.0 [11]
I 13	"Not occupied holiday" mode offset (K) (°C [°F]) In "not occupied holiday" mode, the cooling setpoint is increased by I 13 In "not occupied holiday" mode, the heating setpoint is decreased by I 13 Example: I 13= 5 BHS=20 - I 13= 15°C BCS=25 + I 13= 30°C	5.0 [9]	1.0 [2]	10.0 [18]

Parameter	Description	Default	Min	Max
I 14	Frost protection setpoint (°C [°F])	5.0 [41]	4.0 [39]	10.0 [50]
I 15	Heating setpoint for automatic season changeover sensor (water sensor) (°C [°F]). Used only for the following configurations: M01=2, 5	28.0 [82]	26.0 [79]	40.0 [104]
I 16	Cooling setpoint for automatic season changeover sensor (water sensor) (°C [°F]). Used only for the following configurations: M01=2, 5	17.0 [63]	10.0 [50]	25.0 [77]
I 17	Minimum thermostat setpoint (°C) (constant hysteresis=2°C) Can be used with M07=2, M09=2, M11=2 and when M03≠6 and M05≠6 (see "20. Minimum thermostat" page 30)	21.0 [70]	19.0 [66]	50.0 [122]
I 18	Heating hysteresis for on/off output (K) (°C [°F])	1.0 [1.8]	0.5 [1.0]	2.0 [3.6]
I 19	Cooling hysteresis for on/off output (K) (°C [°F])	1.0 [1.8]	0.5 [1.0]	2.0 [3.6]
I 20	Differential between 2 stages (K) (°C [°F])	2.0 [3.6]	0 [0]	3.0 [5.4]
I 21	Neutral zone for 4 pipe systems (K) (°C [°F])	0.5 [1.0]	0.5 [1.0]	5.0 [9.0]
I 22	Heating proportional band (K) (°C [°F])	2.0 [3.6]	1.0 [1.8]	5.0 [9.0]
I 23	Cooling proportional band (K) (°C [°F])	2.0 [3.6]	1.0 [1.8]	5.0 [9.0]
I 24	Integral time (s). Parameter used to regulate the 0..10V modulating valves If I 24=0, integral action is excluded.	0	0	999
I 25	Speed 1 activation point for 3 speed motor (%) (see ventilation function)	10	1	15
I 26	Speed 2 activation point for 3 speed motor (%) (see ventilation function)	65	30	75
I 27	Speed 3 activation point for 3 speed motor (%) (see ventilation function)	100	80	100
I 28	Speed maintained when setpoint reached. Maintains speed 1 without regulation depending on season. 0=fancoil stopped when setpoint reached 1=fancoil at speed 1 when setpoint reached in heating/cooling modes 2=fancoil at speed 1 when setpoint reached in cooling mode only 3=fancoil at speed 1 when setpoint reached in heating mode only 4=fancoil at manual speed selected when setpoint reached in heating/cooling modes 5=fancoil at manual speed selected when setpoint reached in cooling mode only 6=fancoil at manual speed selected when setpoint reached in heating mode only	0	0	6
I 29	Minimum EC motor starting voltage (see ventilation function)	1.0	0	I 30
I 30	Maximum voltage applicable to EC motor (see ventilation function)	8.0	I 29	10.0
I 31	Starting point of EC motor in regulation (% valve regulation). Enables the EC motor to be started only if the minimum opening percentage set in I 31 has been reached by the valve (see ventilation function)	10	0	100
I 32	Speed 1 of EC motor (% of range I 30 - I 29) 0%=I 29 setting 100%=I 30 setting (see ventilation function)	10	0	15
I 33	Speed 2 of EC motor (% of range I 30 - I 29) 0%=I 29 setting 100%=I 30 setting (see ventilation function)	65	30	75
I 34	Speed 3 of EC motor (% of range I 30 - I 29) 0%=I 29 setting 100%=I 30 setting (see ventilation function)	100	80	100
I 35	Delay on ventilation deactivation (s) (only considered if electric resistance is active) Determines the minimum fan run time following deactivation of the electric resistance to prevent the resistance itself overheating.	30	0	600
I 36	Fan start delay after valve opening (s) Prevent irritating ventilation (too cold in the winter or hot in the summer) and allows the coil to heat or cool enough before starting the fan.	0	10	600
I 37	Fan boost Defines the fan start during regulation 0=Fan starts at set speed 1=Fan starts at maximum speed for 1 s and then goes to set speed	1	0	1
I 38	Air destratification function Determines whether to start the fan at minimum speed if regulation is not active to prevent stratifying the air when the regulation sensor is mounted on the fancoil return. 0=OFF 1=ON in heating and cooling 2=ON in heating only 3=ON in cooling only	1	0	3
I 39	Fan start time during destratification cycle (minutes)	1	1	5

Parameter	Description	Default	Min	Max
I 40	Fan stop time if regulation is not active before starting a new destratification cycle (minutes)	10	1	60
I 41	Maximum fan run time before filter is considered dirty (hours) 0=Not used X=Maximum number of hours of fan operation before a warning is displayed.	2000	0	9990
I 42	Value displayed on <u>display A</u> 0= Internal sensor temperature 1= external sensor temperature AI1 2= external sensor temperature AI2 3= external sensor temperature AI3 4= operating temperature (see " <u>11. Regulation sensor(s)</u> " page 24) 5= humidity reading (only models TH-xxxSH1) 6= operating setpoint (see " <u>14. Working setpoint, Economy mode and holiday mode</u> " page 25) 7= value of 0..10V output AO1 (V) 8= value of 0..10V output AO2 (V) 9= value of 0..10V output AO3 (V)	0	0	9
I 43	Value displayed on <u>display B</u> 0= Internal sensor temperature 1= external sensor temperature AI1 2= external sensor temperature AI2 3= external sensor temperature AI3 4= operating temperature (see " <u>11. Regulation sensor(s)</u> " page 24) 5= humidity reading (only models TH-xxxSH1) 6= operating setpoint (see " <u>14. Working setpoint, Economy mode and holiday mode</u> " page 25) 7= value of 0..10V output AO1 (V) 8= value of 0..10V output AO2 (V) 9= value of 0..10V output AO3 (V) 10= current hours:minutes 11= total hours of fancoil operation 12= measure of input AI3 set as 0...10V input 13= <u>display B</u> switched off	10	0	13
I 44	Mode key function 0= local season changeover with M01=4, M01=7 1= timer extension. 2= operating mode (normal, time zones, or "not occupied holiday")	0	0	2
I 45	Unit of measurement (0=°C, 1=°F)	0	0	1
I 46	Summertime changeover Determines whether summertime is used automatically 0=no 1=yes (European summertime) 2=yes (USA summertime)	1	0	2
I 47	Duration of extension timer (minutes) In timer extension mode, the working setpoint does not consider economy and holiday mode for the time I 47	60	1	480
I 48	Baudrate: Modbus 1=2400, 2=4800, 3=9600, 4=19200, 5=38400 bit/s only TH-xMxSx1 BACnet 3=9600, 4=19200, 5=38400, 6=76800 bit/s only TH-xBxSx1	4 4	1 3	5 6
I 49	Modbus parity (0=none, 1= odd, 2=even) (only models TH-xMxSx1)	2	0	2
I 50	Device's Modbus address (1...247) (only models TH-xMxSx1)	1	1	247
I 51	Reset fancoil hour counter Hours of fancoil operation are memorised. When it exceeds I 41, the icon  is displayed. To reset the counter, enter I 51=1. The parameter returns to 0 automatically after resetting.	0	0	1
I 52	Comfort function 0= current setpoint adjustable in quick access parameter setting 1= offset of setpoint adjustable in quick access parameter setting For further details see paragraph " <u>Setpoint setting</u> " page 8	0	0	1
I 53	Relay for pump (only for model TH-4xxSx1 set as 2-pipe system (M01=2, 3, 4)) 0= relay for pump always deactivated 1= relay for pump activated together with regulation valve	0	0	1

Parameter	Description	Default	Min	Max
I 54	Working season selection in 2-pipe system (M01=2, 5) with temperature of water sensor between I 15 and I 16 (see paragraph <u>"12. Automatic season changeover with water sensor (M01=2 or 5)" page 24</u>) 0= heating (on startup) 1= cooling (on startup) 2= season not defined, regulation stopped	0	0	2
I 55	Low limit of scale for input 0...10V	0	-50	I 56
I 56	High limit of scale for input 0...10V	2000	I 55	9999
I 57	Unit of measure on <u>display B</u> for input 0...10V 0= ppm 1= %r.h. 2= without unit	0	0	2
I 58	Correction for input 0...10V AI3	0	-98.0	98.0
I 59	Fan activation It allows exclusion of the fan 0= fan not used 1= fan used	1	0	1
I 60	BACnet mac address	3	0	254
I 61	BACnet max masters	127	0	127
I 62	BACnet low device ID BACnet device ID = (I 63 x 10000) + I 62	7000	0	9999
I 63	BACnet high device ID BACnet device ID = (I 63 x 10000) + I 62	22	0	419

10. Digital and analogue input logic

• Digital inputs

1. Digital input 1 (DI1):

Parameter		0	1
M03=0 Remote season changeover contact	M04 =	0	1
	Summer		
	Winter		
M03=1 Remote On/Off	M04 =	0	1
	On		
	Off		
M03=2 Not occupied	M04 =	0	1
	"Not occupied holiday" mode		
	Occupied mode		
M03=3 Economy mode	M04 =	0	1
	No economy		
	Economy		
M03=4 Window contact	M04 =	0	1
	Window open		
	Window closed		
M03=5 Alarm	M04 =	0	1
	No alarm		
	Alarm active		
M03=6 Minimum thermostat	M04 =	0	1
	Open		
	Closed		

2. Digital input 2 (DI2):

Parameter		0	1
M05=0 Remote season changeover contact	M06 =	0	1
	Summer		
	Winter		
M05=1 Remote On/Off	M06 =	0	1
	On		
	Off		
M05=2 Not occupied	M06 =	0	1
	"Not occupied holiday" mode		
	Occupied mode		
M05=3 Economy mode	M06 =	0	1
	No economy		
	Economy		
M05=4 Window contact	M06 =	0	1
	Window open		
	Window closed		
M05=5 Alarm	M06 =	0	1
	No alarm		
	Alarm active		
M05=6 Minimum thermostat	M06 =	0	1
	Open		
	Closed		

• **Analogue inputs**

1. Analogue input 1 (AI1)

Parameter			
M07=0 Remote regulation sensor	Sensor AI1 is used in combination with the internal sensor to obtain the final regulation temperature in relation to the value of I 06 (see <i>"11. Regulation sensor(s)" page 24</i>)		
M07=1 Water sensor for season changeover	I 54=0 or 1		
	I 54=2		
	On startup, if the water temperature sensor reading is between I 16 and I 15, see paragraph <i>"12. Automatic season changeover with water sensor (M01=2 or 5)" page 24</i>		
M07=2 Minimum thermostat sensor			
	On startup, if the temperature of the heating coil is between I 17 and I 17 - 2, the minimum thermostat is deemed to be open		
M07=3 Remote season changeover contact	M08 =	0	1
	Summer		
	Winter		
M07=4 Remote On/Off	M08 =	0	1
	On		
	Off		
M07=5 Not occupied holiday day	M08 =	0	1
	"Not occupied holiday" mode		
	Occupied mode		
M07=6 Economy mode	M08 =	0	1
	No economy		
	Economy		
M07=7 Window contact	M08 =	0	1
	Window open		
	Window closed		
M07=8 Alarm	M08 =	0	1
	No alarm		
	Alarm active		
M07=9	Sensor not used		

For configurations M07 from 3 to 8, analogue input 1 is used as digital input. The contact is considered closed if it is short-circuited at the analogue input. The contact is considered open if there is no connection.

Note:

If one or more digital and/or analogue inputs are configured with the same control functionality, then the input with the higher priority is considered.

Input priority:

- Digital input 1 (DI1) - Highest priority
 - Digital input 2 (DI2)
 - Analogue input 1 (AI1)
 - Analogue input 2 (AI2)
 - Analogue input 3 (AI3) - Lowest priority
- ↓

2. Analogue input 2 (AI2)

Parameter											
M09=0 Remote internal sensor	Sensor AI2 is used in combination with the internal sensor to obtain the final regulation temperature in relation to the value of I 06 (see <i>"11. Regulation sensor(s)" page 24</i>).										
M09=1 Water sensor for season changeover	<p>I 54=0 or 1</p>	<p>I 54=2</p>									
On startup, if the water temperature sensor reading is between I 16 and I 15, see paragraph <i>"12. Automatic season changeover with water sensor (M01=2 or 5)" page 24</i>											
M09=2 Minimum thermostat sensor		On startup, if the temperature of the heating coil is between I 17 and I 17 - 2, the minimum thermostat is deemed to be open									
M09=3 Remote season changeover contact	M10 =	<table border="1"> <thead> <tr> <th></th> <th>0</th> <th>1</th> </tr> </thead> <tbody> <tr> <td>Summer</td> <td></td> <td></td> </tr> <tr> <td>Winter</td> <td></td> <td></td> </tr> </tbody> </table>		0	1	Summer			Winter		
	0	1									
Summer											
Winter											
M09=4 Remote On/Off	M10 =	<table border="1"> <thead> <tr> <th></th> <th>0</th> <th>1</th> </tr> </thead> <tbody> <tr> <td>On</td> <td></td> <td></td> </tr> <tr> <td>Off</td> <td></td> <td></td> </tr> </tbody> </table>		0	1	On			Off		
	0	1									
On											
Off											
M09=5 Not occupied holiday	M10 =	<table border="1"> <thead> <tr> <th></th> <th>0</th> <th>1</th> </tr> </thead> <tbody> <tr> <td>"Not occupied holiday" mode</td> <td></td> <td></td> </tr> <tr> <td>Occupied mode</td> <td></td> <td></td> </tr> </tbody> </table>		0	1	"Not occupied holiday" mode			Occupied mode		
	0	1									
"Not occupied holiday" mode											
Occupied mode											
M09=6 Economy mode	M10 =	<table border="1"> <thead> <tr> <th></th> <th>0</th> <th>1</th> </tr> </thead> <tbody> <tr> <td>No economy mode</td> <td></td> <td></td> </tr> <tr> <td>Economy mode</td> <td></td> <td></td> </tr> </tbody> </table>		0	1	No economy mode			Economy mode		
	0	1									
No economy mode											
Economy mode											
M09=7 Window contact	M10 =	<table border="1"> <thead> <tr> <th></th> <th>0</th> <th>1</th> </tr> </thead> <tbody> <tr> <td>Window open</td> <td></td> <td></td> </tr> <tr> <td>Window closed</td> <td></td> <td></td> </tr> </tbody> </table>		0	1	Window open			Window closed		
	0	1									
Window open											
Window closed											
M09=8 Alarm	M10 =	<table border="1"> <thead> <tr> <th></th> <th>0</th> <th>1</th> </tr> </thead> <tbody> <tr> <td>No alarm</td> <td></td> <td></td> </tr> <tr> <td>Alarm active</td> <td></td> <td></td> </tr> </tbody> </table>		0	1	No alarm			Alarm active		
	0	1									
No alarm											
Alarm active											
M09=9	Sensor not used										

For configurations M09 from 3 to 8, analogue input 1 is used as a digital input. The contact is considered closed if it is short-circuited at the analogue input. The contact is considered open if there is no connection.

Note:

If one or more digital and/or analogue inputs are configured with the same control functionality, then the input with the higher priority is considered.

Input priority:

Digital input 1 (DI1)	-	Highest priority
Digital input 2 (DI2)		
Analogue input 1 (AI1)		
Analogue input 2 (AI2)		
Analogue input 3 (AI3)	-	Lowest priority

↓

3. Analogue input 3 (AI3):

Parameter											
M11=0 Remote internal sensor	Sensor AI3 is used in combination with the internal sensor to obtain the final regulation temperature in relation to the value of I 06 (see <i>"11. Regulation sensor(s)" page 24</i>)										
M11=1 Water sensor for season changeover	<p>I 54=0 or 1</p> <p>I 54=2</p> <p>On startup, if the water temperature sensor reading is between I 16 and I 15, see paragraph <i>"12. Automatic season changeover with water sensor (M01=2 or 5)" page 24</i></p>										
M11=2 Minimum thermostat sensor	<p>On startup, if the temperature of the heating coil is between I 17 and I 17 - 2, the minimum thermostat is deemed to be open</p>										
M11=3 Remote season changeover contact	M12 =	<table border="1"> <thead> <tr> <th></th> <th>0</th> <th>1</th> </tr> </thead> <tbody> <tr> <td>Summer</td> <td></td> <td></td> </tr> <tr> <td>Winter</td> <td></td> <td></td> </tr> </tbody> </table>		0	1	Summer			Winter		
	0	1									
Summer											
Winter											
M11=4 Remote On/Off	M12 =	<table border="1"> <thead> <tr> <th></th> <th>0</th> <th>1</th> </tr> </thead> <tbody> <tr> <td>On</td> <td></td> <td></td> </tr> <tr> <td>Off</td> <td></td> <td></td> </tr> </tbody> </table>		0	1	On			Off		
	0	1									
On											
Off											
M11=5 Not occupied holiday	M12 =	<table border="1"> <thead> <tr> <th></th> <th>0</th> <th>1</th> </tr> </thead> <tbody> <tr> <td>"Not occupied holiday" mode</td> <td></td> <td></td> </tr> <tr> <td>Occupied mode</td> <td></td> <td></td> </tr> </tbody> </table>		0	1	"Not occupied holiday" mode			Occupied mode		
	0	1									
"Not occupied holiday" mode											
Occupied mode											
M11=6 Economy mode	M12 =	<table border="1"> <thead> <tr> <th></th> <th>0</th> <th>1</th> </tr> </thead> <tbody> <tr> <td>No economy</td> <td></td> <td></td> </tr> <tr> <td>Economy</td> <td></td> <td></td> </tr> </tbody> </table>		0	1	No economy			Economy		
	0	1									
No economy											
Economy											
M11=7 Window contact	M12 =	<table border="1"> <thead> <tr> <th></th> <th>0</th> <th>1</th> </tr> </thead> <tbody> <tr> <td>Window open</td> <td></td> <td></td> </tr> <tr> <td>Window closed</td> <td></td> <td></td> </tr> </tbody> </table>		0	1	Window open			Window closed		
	0	1									
Window open											
Window closed											
M11=8 Alarm	M12 =	<table border="1"> <thead> <tr> <th></th> <th>0</th> <th>1</th> </tr> </thead> <tbody> <tr> <td>No alarm</td> <td></td> <td></td> </tr> <tr> <td>Alarm active</td> <td></td> <td></td> </tr> </tbody> </table>		0	1	No alarm			Alarm active		
	0	1									
No alarm											
Alarm active											
M11=9	Sensor not used										
M11=10	Input 0...10V										

For configurations M11 from 3 to 8, analogue input 1 is used as a digital input. The contact is considered closed if it is short-circuited at the analogue input. The contact is considered open if there is no connection.

Note:

If one or more digital and/or analogue inputs are configured with the same control functionality, then the input with the higher priority is considered.

Input priority:

Digital input 1 (DI1)	-	Highest priority
Digital input 2 (DI2)		
Analogue input 1 (AI1)		
Analogue input 2 (AI2)		
Analogue input 3 (AI3)	-	Lowest priority

↓

11. Regulation sensor(s)

The sensor used for control can be:

- the internal controller sensor
- an external sensor selected between **AI1, AI2, AI3**.
- the internal controller sensor combined to any of the remote sensor **AI1, AI2, AI3** with a certain weight This permits to obtain an optimized control in rooms where temperature may be different from one side to another

To use the internal sensor as a control sensor, set parameter I 06 to 0.

To use external sensor **AI1** as a control sensor, set parameter M07=0 and I 06=100.

To use the internal sensor together with sensor **AI1** with a 25% weighting of remote sensor **AI1**, set parameters M07=0 and I 06=25.

The operating temperature becomes $T_{reg} = [T_i (100 - I 06) + (T_{AI1} \times I 06)] / 100$

with T_i =internal sensor temperature, T_{AI1} =remote sensor temperature **AI1**.

In the case one or more sensors are configured as external working sensors (M07=0 and/or M09=0 and/or M11=0), only one sensor is considered to be combined with the internal sensor: the sensor with highest priority.

The sensor **AI1** has priority over sensor **AI2**, and sensor **AI2** has priority over sensor **AI3**.

Note: if no external sensor is used as a remote sensor (M07≠0, M09≠0, M11≠0), the internal sensor is used as the control sensor even if I 06 is different from 0.

12. Automatic season changeover with water sensor (M01=2 or 5)

The selection of working season is done automatically (for operating modes M01=2 or 5) by external sensor set as water sensor (M07=1 or M09=1 or M11=1). According to parameter's value I 54, season changeover is done on the following way:

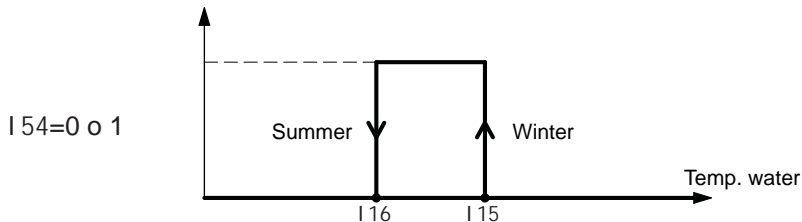

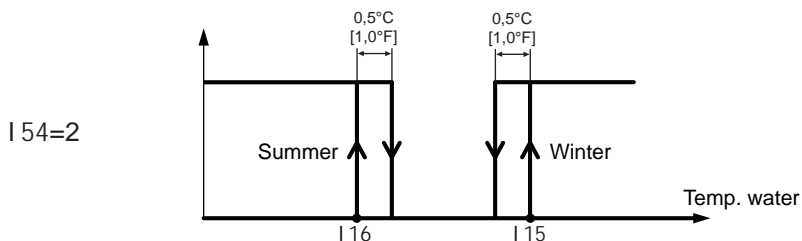

On startup, if temperature of water sensor is between I 16 and I 15 the working season is heating (if I 54=0) or cooling (if I 54=1). If temperature of water sensor then increases and reaches I 15, the working season becomes heating. If temperature of water sensor then decreases and reaches I 16, the working season becomes cooling.



On startup, if temperature of water sensor is between I 16 and I 15 the working season is not defined and no regulation takes place. If temperature of water sensor then increases and reaches I 15, the working season becomes heating. If temperature of water sensor then decreases and reaches I 15 - 0.5°C [1.0°F], the working season is not defined and regulation is stopped. If temperature of water sensor then decreases and reaches I 16, the working season becomes cooling. If temperature increases and reaches I 16 + 0.5°C [1.0°F], the working season is not defined and regulation is stopped.

13. Frost protection

If operating temperature falls below I 14 (frost setpoint), heating outputs are activated and the fan starts at maximum speed (if

heating outputs are present) and icons  and  flash.

If operating temperature rises above I 14 + 2°C, the frost protection is deactivated.

Note: frost protection is active even if device is OFF

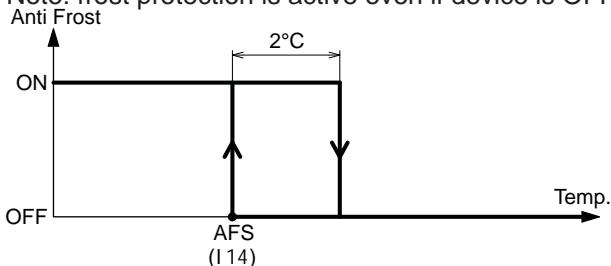

14. Working setpoint, ECONOMY mode and HOLIDAY mode

If a digital contact is configured as remote contact “not occupied holiday” M03=2 or M05=2 or a remote sensor is configured as remote contact “not occupied holiday” M07=5 or M09=5 or M11=5, “not occupied holiday” mode can be activated if the corresponding contact is in the appropriate position (see digital and analogue input logic).

Installations different from 4 pipe system (M01≠8 and 9):

In “not occupied holiday” mode, the heating setpoint is decreased by I 13 (see chart 2 pipe heating, WHS), the cooling setpoint is increased by I 13 (see chart 2 pipe cooling, WCS).

Installations with 4 pipe system (M01=8 and 9):

In “not occupied holiday” mode, the heating activation point is decreased by I 13 (see chart 4 pipe heating, WHS), the cooling activation point is increased by I 13 (see chart 4 pipe cooling, WCS).

The icon  is activated to indicate that “not occupied holiday” mode is active.

If one of the digital contacts is configured as remote contact “energy saving” M03=3 or M05=3 or a sensor is configured as remote contact “energy saving” M07=6 or M09=6 or M11=6, energy saving mode can be activated if the corresponding contact is in the appropriate position (see digital and analogue inputs logic).

Installations different from 4 pipe system (M01≠8 and 9):

In economy mode, the heating setpoint is decreased by I 12 (see chart 2 pipe heating, WHS), the cooling setpoint is increased by I 12 (see chart 2 pipe cooling, WCS).

Installations with 4 pipe system (M01=8 and 9):

In economy mode, the heating activation point is decreased by I 12 (see chart 4 pipe heating, WHS), the cooling activation point is increased by I 12 (see chart 4 pipe cooling, WCS).

The “ECO” icon is activated to indicate “energy saving” mode.

The “not occupied holiday” mode has priority over economy mode when both modes are activated.

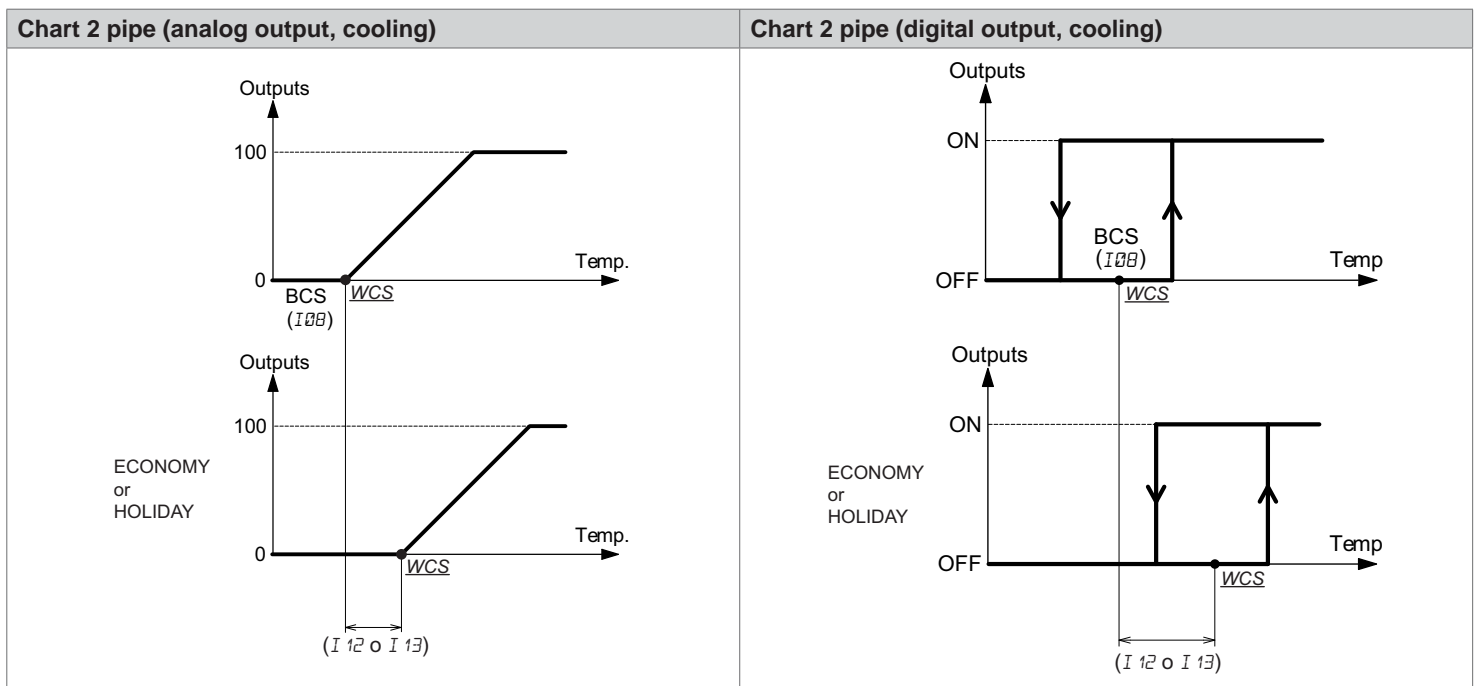

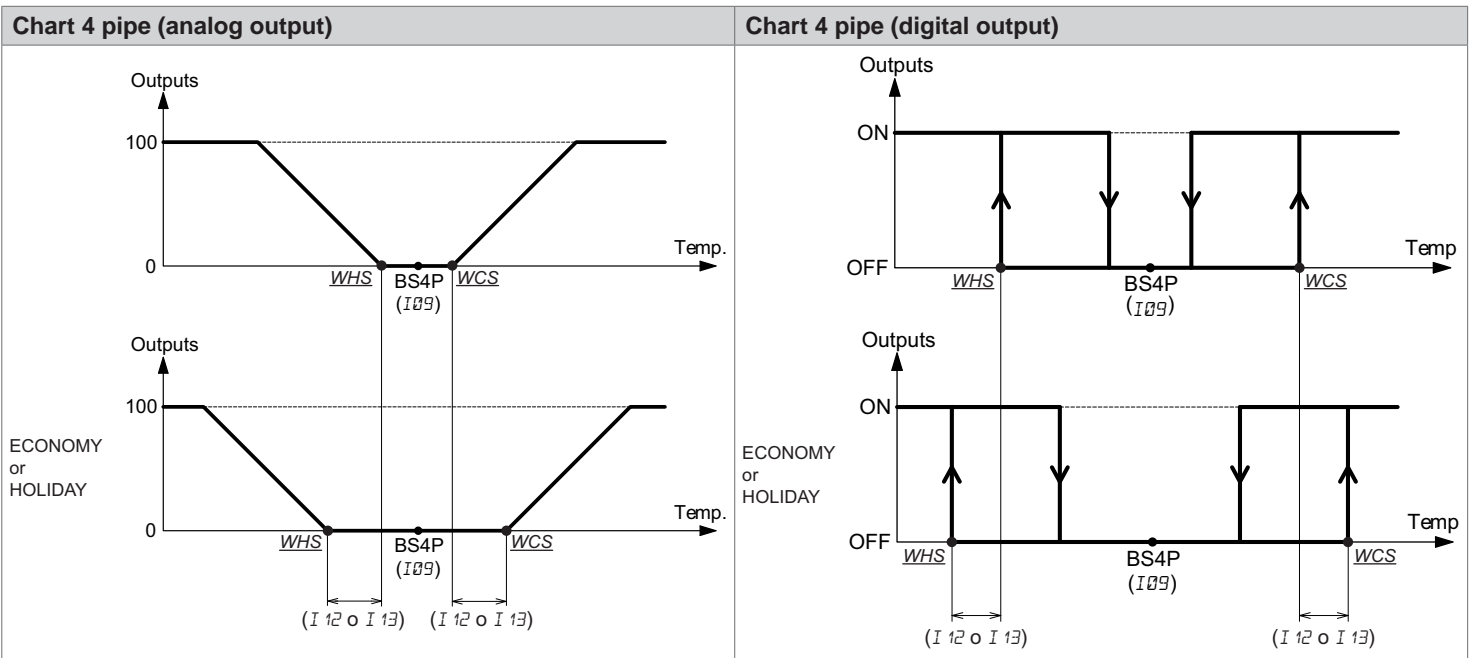
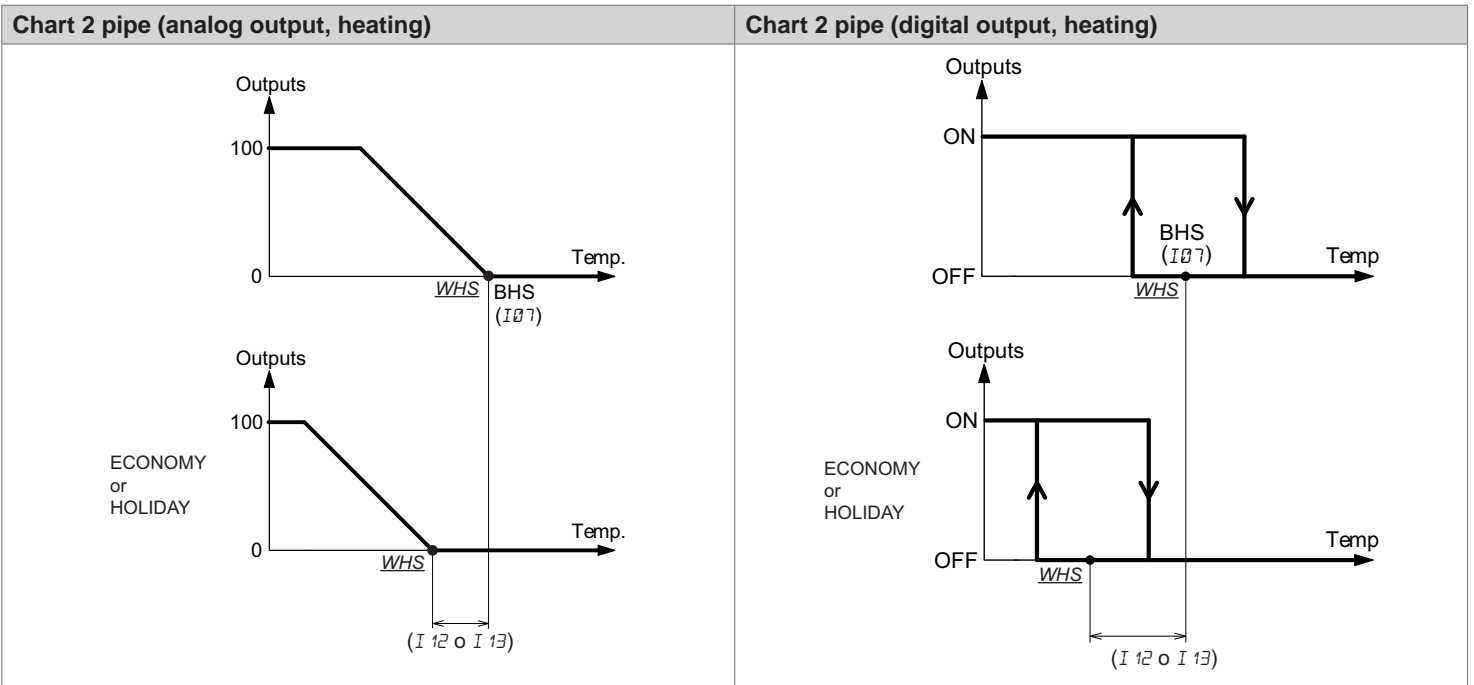

It is possible to visualize the working setpoint by setting parameter I 42 or I 43 to 6. On this case the value of WHS is visualized in heating mode, the value of WCS is visualized in cooling mode and if working season is not defined (I 54=2, and temperature of water sensor between I 15 and I 16), the message “---” is visualized.

If no contacts or sensors are configured in “not occupied holiday” or “energy saving” mode, and if the operating mode has been set manually with time zones (see “4. Quick access parameter setting” page 8), then within the time zone regulation is controlled with the basic setpoint; in this case “display C” (see “3. Display, keyboard and icons” page 7) indicates the number of the active zone. Outside the time zone, economy mode is active.

Otherwise, the contact or sensor status configured in “not occupied holiday” or “energy saving” mode has higher priority, and time zones are not considered (**TH-xxCSx1** models)

If no contacts or sensors are configured as “not occupied holiday” or “energy saving” and if operating mode is in holiday mode (manually set using quick access parameters → see “MODE button functionality” page 9), holiday mode is active. Otherwise the contact or sensor status configured in the “not occupied holiday” or “energy saving” mode has priority over manual setting.

When timer extension mode is activated manually, it takes priority over energy saving, holiday (see “15. Timer extension mode” page 27) and time zone modes (**TH-xxCSx1** models).

15. Timer extension mode

If the “energy saving”, “not occupied holiday” and time zone modes are active, the operating setpoints are calculated in relation to parameters I 12 (economy offset) and I 13 (“not occupied holiday” offset).

It is possible to bypass these functions for a certain time (parameter I 47) and to maintain control with the base setpoints, by activating timer extension mode.

Timer extension mode can be activated manually by setting parameter MOC to 0C (see “*MODE button functionality*” page 9). Once activated, a delay equal to the value of I 47 must expire before normal operation resumes.

16. Fancoil with EC motor (models TH-0xxSx1, TH-1xxSx1, TH-2xxSx1)

Parameter M13=0.

Device is able to control 2 EC motors with parameter M14.

If M14=0, 2 outputs are used to control the EC motor: one relay output and one 0...10V analogue output.

When the motor starts, the relay output is activated first, while the analogue output remains at 0V.

After 1 second, the analogue output is also activated.

When the motor is stopped, the analogue output returns to 0V.

After 1 second, the relay is deenergized.

If M14=1, only the analogue 0...10V output is activated to control the EC motor, without the auxiliary relay.

• EC motor automatic speed control logic with on/off outputs

Depending on the value of the stage 1 differential, a fan temperature band (FB) is set, within which the fancoil speed can vary from speeds 1 to 3.

Hysteresis	0.5 - 1.0 °C	> 1.0...1.5 °C	> 1.5...2.0 °C
FB	2.0 °C	3.0 °C	4.0 °C

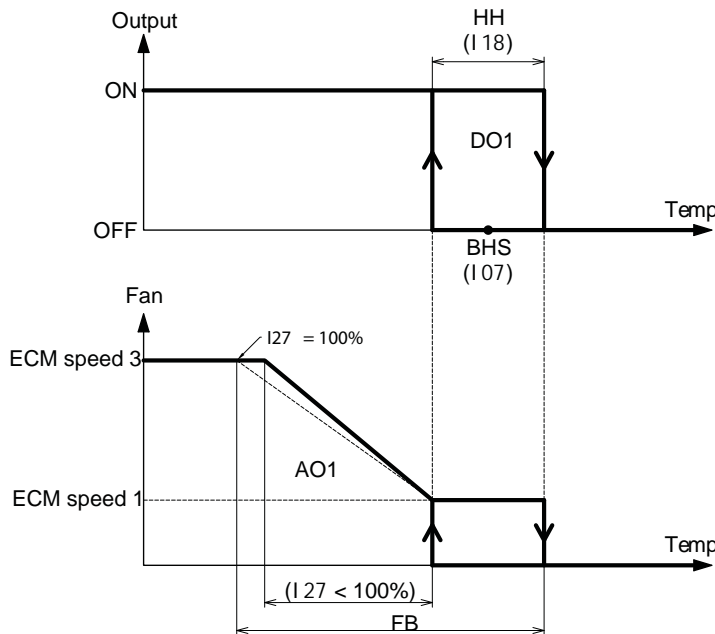

The graph refers to heating mode operation.

Set the EC motor parameters as follows:

- Set the voltage corresponding to the minimum EC motor speed with parameter I 29.
- Set the voltage corresponding to the maximum EC motor speed with parameter I 30.
- Set parameters I 32, I 33, I 34 for speeds 1, 2, 3 respectively.

Example: if I 29=1V, I 30=8V and I 32=10%, speed 1 corresponds to 1.7V → $[I 32 \times (I 30 - I 29) + I 29]$

Automatic speed control is linear over the range of speeds 1 to 3, while manual control simply sets a given speed (see “*4. Quick access parameter setting*” page 8).

To set speed 1 to the minimum EC motor speed, set I 32 to 0. To set speed 3 to the maximum EC motor speed, set I 34 to 100.

To set speed 2 to the midpoint between speeds 1 and 3, set I 33 to 50.

- Set I 27 to define the point at which maximum speed is reached within the fan band.

N.B.: parameters I 25 and I 26 are not used in this application.

The activation/deactivation of the fancoil at speed 1 correspond to the activation/deactivation of stage 1.

• EC motor automatic speed control logic with 0..10 V modulating outputs

We take the example of control in heating mode.

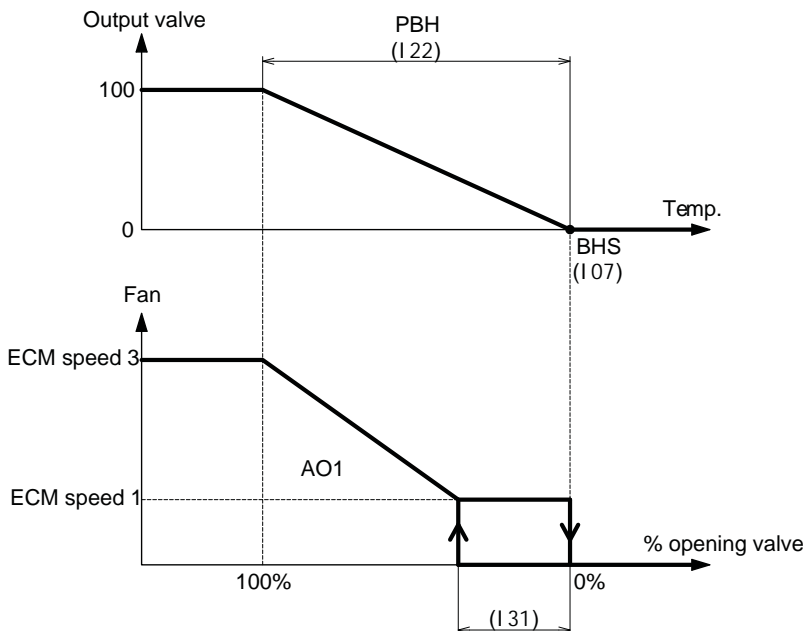

The graph refers to heating mode.

Set the EC motor parameters as follows:

- Set the voltage corresponding to the minimum EC motor speed with parameter I 29.
- Set the voltage corresponding to the maximum EC motor speed with parameter I 30.
- Set parameters I 32, I 33, I 34 for speeds 1, 2, 3 respectively.

Example: if I 29=1V, I 30=8V and I 32=10%, speed 1 corresponds to 1.7V $\rightarrow [I\ 32 \times (I\ 30 - I\ 29) + I\ 29]$

Automatic speed control is linear over the range of speeds 1 to 3, while manual control simply sets a given speed (see ["4. Quick access parameter setting" page 8](#)).

To set speed 1 to the minimum EC motor speed, set I 32 to 0.

To set speed 3 to the maximum EC motor speed, set I 34 to 100.

To set speed 2 to the midpoint between speeds 1 and 3, set I 33 to 50.

- Set parameter I 31 to determine the point at which the motor starts in relation to the valve's opening percentage.

This enables the fan to start when water is already circulating in the fancoil coil.

Example: if I 31=5%, the motor starts when the valve's modulating output exceeds 0.5V $\rightarrow [I\ 31 \times 10\ V]$. The fan stops when the valve closes.

N.B.: parameters I 24, I 25 and I 26 are not used in this application.

17. Fancoil with 3 speed on-off motor (models TH-2xxSx1, TH-3xxSx1, TH-4xxSx1)

Parameter M13=1.

The device can control 3 speed on-off fancoils. Parameter M14 is not considered in this case.

• 3 speed on-off motor speed control logic with on/off outputs

Depending on the value of the stage 1 differential, a fan temperature band (FB) is set, within which the fancoil speed can vary from speeds 1 to 3.

Hysteresis	0.5 - 1.0 °C	> 1.0...1.5 °C	> 1.5...2.0 °C
FB	2.0 °C	3.0 °C	4.0 °C

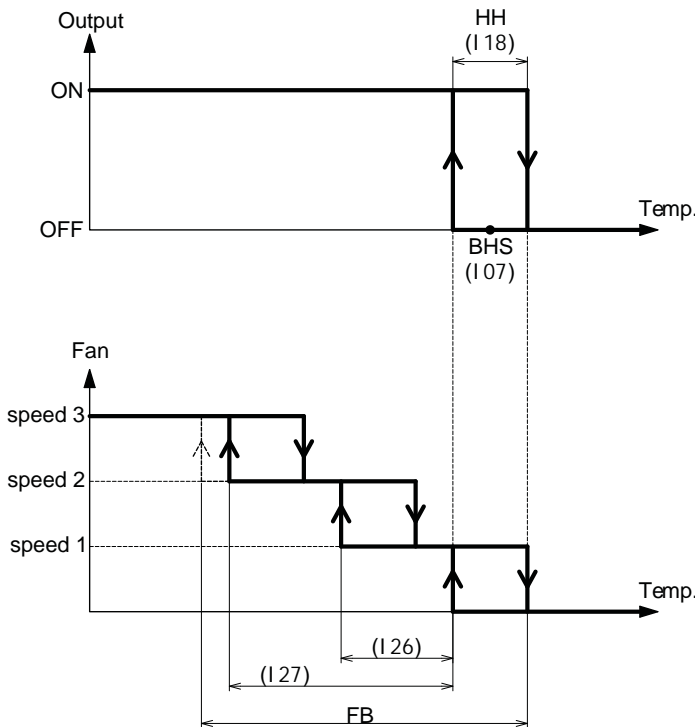

The graph refers to heating mode operation.

Set the 3 speed on-off motor parameters as follows:

- Set parameters I 26, I 27 to define the activation points of speeds 2 and 3 within the fan band.

Example: if Stage 1 hysteresis=0.5°C, FB=2°C and I 26=50%, I 27=100%, then speed 2 starts at 0.75°C → [I 26 x (FB - hysteresis)] below the activation point of speed 1 and speed 3 starts 1.5°C → [I 27 x (FB - hysteresis)] below the activation point of speed 1.

The hysteresis of speeds 2 and 3 corresponds to 20% of the FB band.

The activation/deactivation of speed 1 correspond to the activation/deactivation of stage 1.

N.B.: parameters I 25, I 29 and I 34 are not used in this application.

• 3 speed on-off motor speed control logic with 0...10V modulating outputs

We take the example of control in heating mode.

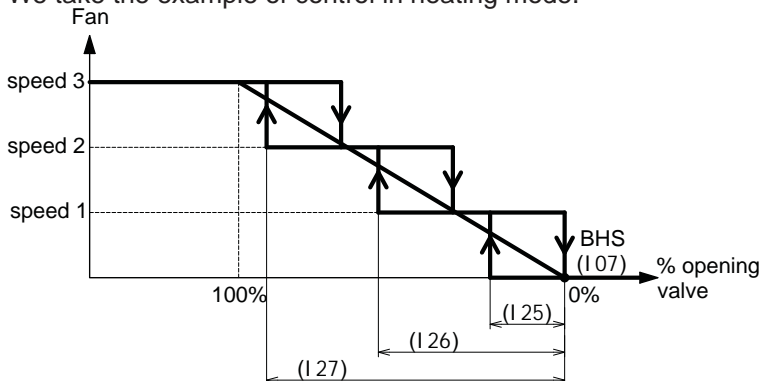

Set the 3 speed on-off motor parameters as follows:

- Set parameters I 25, I 26 and I 27 to define the activation points of speeds 1, 2 and 3 in relation to the valve opening.

Example: with I 25=5%, I 26=50%, I 27=100%

speed 1 starts when the valve is at ≥ 5% of its total aperture.

speed 2 starts when the valve is at ≥ 50% of its total aperture.

speed 3 starts when the valve is at ≥ 100% of its total aperture.

Speed 1 is deactivated when the valve is closed.

The hysteresis of speeds 2 and 3 corresponds to 20% of the respective activation point.

In the above example:

speed 2 deactivates when the valve is at $\leq 40\%$ (50% - 20% of 50) of its total aperture.
speed 3 deactivates when the valve is at $\leq 80\%$ (100% - 20% of 100) of its total aperture.

N.B.: parameters I 29 to I 34 are not used in this application.

18. Manual speeds and ventilation maintenance with no control

The regulation speed type can be selected automatically or manually, at speeds 1, 2 and 3. To see how to select the type of ventilation, see *"Fancoil operating mode" page 9*.

If the regulation speed is manual, it stays at the set speed once started throughout regulation.

When it reaches the setpoint, the fan stops if I 28=0.

You can keep speed 1 active or the manual speed selected, regardless of the type of speed used in regulation, even if the regulation itself does not require it. This maintains constant ventilation to keep the air circulating.

To keep speed 1 active in cooling without regulation, set I 28=2.

To keep speed 1 active in heating without regulation, set I 28=3.

To keep speed 1 active regardless of the season and without regulation, set I 28=1.

To keep manual speed selected active in cooling without regulation, set I 28=5.

To keep manual speed selected active in heating without regulation, set I 28=6.

To keep manual speed selected active regardless of the season and without regulation, set I 28=4.

To stop ventilation once the setpoint is reached, set I 28=0.

19. Fan boost

The boost function eliminates the problem of incorrect motor starting at low speeds.

Set I 37=1, this starts the motor at maximum speed for 1 second, after which it runs at the regulation speed.

If this option is not wanted, set I 37=0.

When I 37=0, the motor starts directly at the regulation speed.



20. Minimum thermostat

In all heating modes, when a digital input is set as minimum thermostat (M03=6 or M05=6) or remote sensor is configured as minimum thermostat M07=2 or M09=2 or M11=2, ventilation does not start until the minimum thermostat is closed.

For digital contacts, the minimum thermostat is considered closed, in relation to the position of the contact and the digital contact logic (see *"10. Digital and analogue input logic" page 20*).

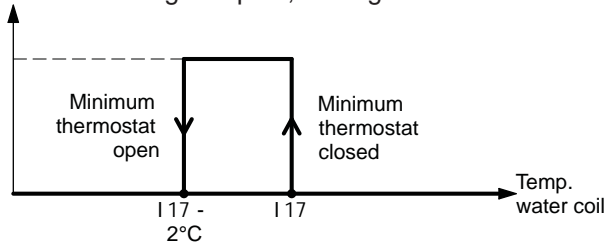
For the analogue inputs, the logic is as follows:



On startup, if the temperature of the heating coil is between I 17 and I 17 - 2, the minimum thermostat is deemed to be open. Icons ,  and  turn on in sequence when the minimum thermostat is open during heating mode without electric resistance.

N.B.: if the electric resistance is present, the minimum thermostat function is not considered. The fan is activated immediately when the electric resistance is activated even if the minimum thermostat is considered to be open.

If no regulation is present or in cooling mode, the minimum thermostat is not considered.

21. Destratification cycle

This function prevents stratification of the air and a better temperature reading from the remote sensor on the fan's return. If there is no regulation and the fan is off (I 28=0), you can start the destratification function in relation to the season.

To start the function in both heating and cooling modes, set I 38=1.

To start the function in heating mode only, set I 38=2.

To start the function in cooling mode only, set I 38=3.

When the destratification function is active, the fan starts at speed 1 and the icon  flashes for the time set in I 39 every interval set in I 40.

22. Dirty filter

The dirty filter function counts the hours of operation of the fancoil and displays a warning message with the icon  when the counter exceeds the number of hours set in parameter I 41.

The filter is then considered to be dirty and must be changed.

To activate the dirty filter function, set the maximum number of hours with I 41 (not equal to zero).

To deactivate this function, set the maximum number of hours with I 41=0.

When the function is active, the fancoil hours counter is saved to memory every 2 hours. To reset the counter, set I 51=1. The counter is then reset, parameter I 51 sets itself to 0 automatically and the icon  stops flashing until the counter exceeds the value of I 41 again.

N.B.: when the function is deactivated, the fancoil hours are not counted.

23. Window contact

In all modes, when a digital input is used as the window contact MO3=4 or MO5=4 or a remote sensor is configured as window contact MO7=7, MO9=7 or M11=7, the outputs are disabled if the window contact is open.

The icon  flashes when the window contact is considered open.

If an electric resistance is active (MO2=1, 2 or 3) ventilation is stopped after delay I 35 has expired so as to disperse the heat generated by the resistance.

24. Summertime changeover

The device is configured to change to summertime automatically in certain areas of the world.

To use this function, set I 46=1 if the controller is in use in Europe.

Set I 46=2 for the USA. In the last case, also set the unit of measurement to °F by setting I 45=1. All temperature parameters will then be expressed in °F and the controller will use this unit automatically.

For all areas outside Europe and the USA, set I 46=0. The change to summertime is not automatic in this case. You must set the time manually depending on local regulations.

25. Sensor AI3 used as input 0...10V

If sensor AI3 is used as 0...10V input, set the jumper JP1 on position 2-3 and set parameter M11 to 10. Then set the scale for this input by parameters I 55 (low limit of scale) and I 56 (high limit of scale). Set parameter I 43 to 12 in order to visualize the corresponding measure. For corresponding unit set parameter I 57 (0=ppm, 1=%r.h., 2=no unit). It is possible to correct the value visualized by parameter I 58.

The value visualized on the display can be with or without decimal point based on the range of the scale.

26. Outputs forced via Modbus

It is possible to force each output via Modbus independently from regulation. To abilitate this function write on address FORCED_OUTPUTS_KEY (3070) the forced key and then write the required value on the register corresponding to the output.

Forced key definition

The forced key is a 16 bit variable, it has 2 parts, the high part has a constant value (01100110), and the low part is variable based on outputs that have to be forced.

High part	Low part							
bit from 15 to 8	bit 7	bit 6	bit 5	bit 4	bit 3	bit 2	bit 1	bit 0
01100110 constant value	x AO3	x AO2	x AO1	x DO5	x DO4	x DO3	x DO2	x DO1

x=0 corresponds to output not abilitated to be forced (the output is set by regulation);

x=1 corresponds to output abilitated to be forced. The output is disconnected from regulation and take the value of corresponding register set by Modbus.

Output abilitated to be forced	Modbus writing register and address	
AO3	OUT_C	3014
AO2	OUT_B	3013
AO1	OUT_A	3012
DO5	STATE_REL5	3011
DO4	STATE_REL4	3010
DO3	STATE_REL3	3009
DO2	STATE_REL2	3008
DO1	STATE_REL1	3007

Example:

Abilitation of output relay 1 to be forced:

Forced key = 01100110 00000001 in binary, 26113 in decimal.

Write 26113 to variable FORCED_OUTPUTS_KEY.

Relay activation: write 1 to variable STATE_REL1.

Relay deactivation: write 0 to variable STATE_REL1.

Abilitation of analog output **AO2**:

Forced key = 01100110 01000000 in binary, 26176 in decimal.

Write 26176 to variable FORCED_OUTPUTS_KEY.

Output set to 3.4V: write 34 to variable OUT_B

It is possible to abilitate more than one output in forced mode.

Example:

Abilitation of outputs relay 2, 3 and analog output **AO1** to be forced:

Forced key = 01100110 00100110 in binary, 26150 in decimal.

Write 26150 to variable FORCED_OUTPUTS_KEY.

Relay 2 activation: write 1 to variable STATE_REL2.

Relay 3 activation: write 1 to variable STATE_REL3.

Output set to 4.2V: write 42 to variable OUT_A

On forced output mode the  485 icon is switched on inside the menu setpoint.

To exit forced mode of output, write 0 to FORCED_OUTPUTS_KEY.

Note:

if regulator is connected to a master system control and the option of force mode is abilitated, AB Industrietechnik will not be considered responsible for damage due to erroneous drive of these outputs.

27. Alarms

There are two types of alarm:

alarms which do not affect the controller (only error messages are displayed);

alarms which do affect the controller (error messages are displayed and certain outputs are disabled);

Digital contacts configured as alarms and temperature sensors configured as remote contacts with an alarm function do not affect regulation.

When an alarm occurs, it is displayed on display A during regulation. To return to the normal regulation display, press button



to change display A.

If the sensor displayed on display A is in alarm, press button



to display the following screen if the sensor is open:



or



if the sensor is in short circuit.

You can display the status of alarms in the alarms page. To access the alarms page, proceed as follows:

Press buttons and together to access the main menu. The following screen is displayed:



(model **TH-xxCSx1**) or



(model **TH-xxSSx1**)

For models with clock, use button or to display the following screen:



Display A displays the alarms page and display B displays an alarm message (see tables below).

Alarm message tables (from contact)

	D11 (M03=5) and/or AI1 (M07=8)	DI2 (M05=5) and/or AI2 (M09=8)	AI3 (M11=8)
EE1	Alarm	No alarm	No alarm
EE2	No alarm	Alarm	No alarm
EE3	Alarm	Alarm	No alarm
EE4	No alarm	No alarm	Alarm
EE5	Alarm	No alarm	Alarm
EE6	No alarm	Alarm	Alarm
EE7	Alarm	Alarm	Alarm

For the position of the contact corresponding to the alarm position, refer to *"10. Digital and analogue input logic" page 20*.

Temperature sensors configured as internal or remote sensors or water sensor for automatic season changeover (2 pipe) or minimum thermostat sensor have the following alarm messages, if the sensor is open or in short circuit.

Table of alarms (temperature sensors)

	AI3 (M11=0/1/2)	AI2 (M09=0/1/2)	AI1 (M07=0/1/2)	Internal sensor
E01	No alarm	No alarm	No alarm	Alarm
E02	No alarm	No alarm	Alarm	No alarm
E03	No alarm	No alarm	Alarm	Alarm
E04	No alarm	Alarm	No alarm	No alarm
E05	No alarm	Alarm	No alarm	Alarm
E06	No alarm	Alarm	Alarm	No alarm
E07	No alarm	Alarm	Alarm	Alarm
E08	Alarm	No alarm	No alarm	No alarm

E09	Alarm	No alarm	No alarm	Alarm
E10	Alarm	No alarm	Alarm	No alarm
E11	Alarm	No alarm	Alarm	Alarm
E12	Alarm	Alarm	No alarm	No alarm
E13	Alarm	Alarm	No alarm	Alarm
E14	Alarm	Alarm	Alarm	No alarm
E15	Alarm	Alarm	Alarm	Alarm

If the sensors used to define the operating temperature are all faulty (open or in short circuit), the outputs are deactivated and the fancoil is stopped.

Example:

M07=0 sensor **A11** used as remote sensor in combination with the internal sensor.

If sensor **A11** is broken, the operating temperature becomes that of the internal sensor, regardless of the value of parameter I 06.

If the internal sensor is broken, the operating temperature becomes that of sensor **A11**, regardless of the value of parameter I 06.

If both are broken, the operating temperature cannot be determined. Regulation is stopped.

For sensors used as automatic season changeover water sensor (2 pipe) or minimum thermostat sensor, if the sensor fails its function is not excluded.

If a remote sensor is used as an automatic season changeover water sensor:

- in case of short circuit, the sensor temperature is considered to be high and the mode is considered to be heating.
- in case of open sensor, the sensor temperature is considered to be low and the mode is considered to be cooling.

If a remote sensor is used as the minimum thermostat:

- in case of short circuit, the sensor temperature is considered to be high and the minimum thermostat is considered to be closed.
- in case of sensor open, the sensor temperature is considered to be low and the minimum thermostat is considered to be open.

For input sensor **A13** used as 0...10V (M11=10 and jumper JP1 set on position 0...10V) the message “**L-HI**” (> 10V) is visualized on the [display B](#) and E08 on the [display A](#) in alarm condition.

On the alarm page message E08 is showed.



Table of alarms (clock only for model **TH-xxCSx1**)

ECL	Clock reading error
-----	---------------------



Clock malfunction.

28. Resetting the default parameters

The initial (default) configuration of the parameters can be reloaded as follows:

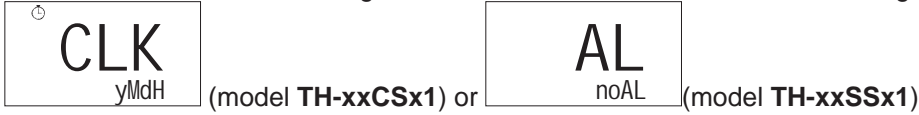
Press buttons  and  together to access the main menu. The following screen is displayed:



Press button  or  to display the following screen:



Press button  and then button  until the value **33** is displayed.

Press button  to access the default parameters reset level.



To abort and return to regulation, press .

To start the procedure, press , the value 0 flashes. Press button  to set the value to 1 and press  again.

The reset procedure starts. The display reports the following messages:



Loading default settings...



Default settings loaded

When the following screen is displayed again you can quit the menu by pressing  once or waiting 120 seconds.



29. Control with EC motor (Model TH-0xxSx1)

All the graphics below refer to automatic speed control.

• **HEATING mode (M01=0)**

The “HEAT” icon is on to indicate that heating mode is active.

The regulation uses the following automatic speed control logic:

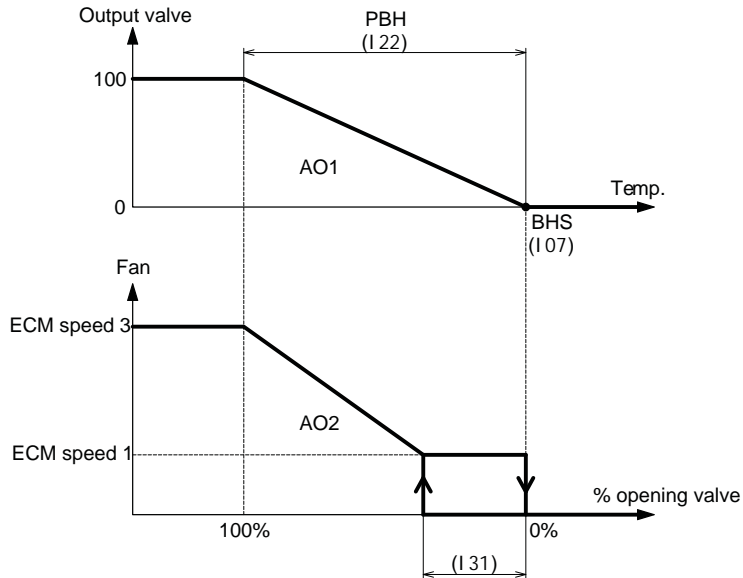

If the operating temperature drops below I07, the valve starts opening (output **AO1**). Icon  turns on.

The valve can be regulated with PI action if the integral time I24 is non-zero or with only proportional action if I24=0.

The fan (output **AO2**) starts when the valve reaches the minimum aperture given by parameter I31, and after the fan start delay I36 has expired.

The speed increases linearly as the valve opens. Speed 3 is reached when the valve is fully open (see [“16. Fancoil with EC motor \(models TH-0xxSx1, TH-1xxSx1, TH-2xxSx1\)” page 27](#)

[“EC motor automatic speed control logic with 0..10 V modulating outputs” page 28.](#)

Icon  turns off when the valve closes again, in which case the fan stops if I28=0 or 2. The fan maintains speed 1 if I28=1 or 3.

The fan maintains speed selected manually if I28=4 or 6.

N.B.: if the minimum thermostat function is active, the thermostat itself must be closed when the valve is in regulation, otherwise the fan will not start.

Wiring diagram

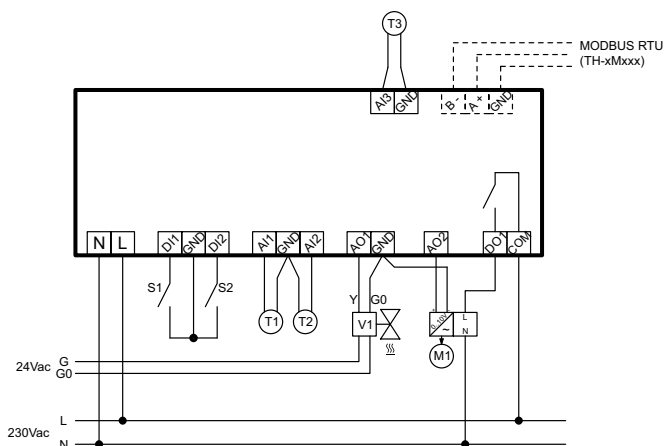

TH-0xxSx1

• **HEATING/HEATING mode (M01=1)**

The “HEAT” icon is on to indicate that heating mode is active.

The regulation uses the following automatic speed control logic:

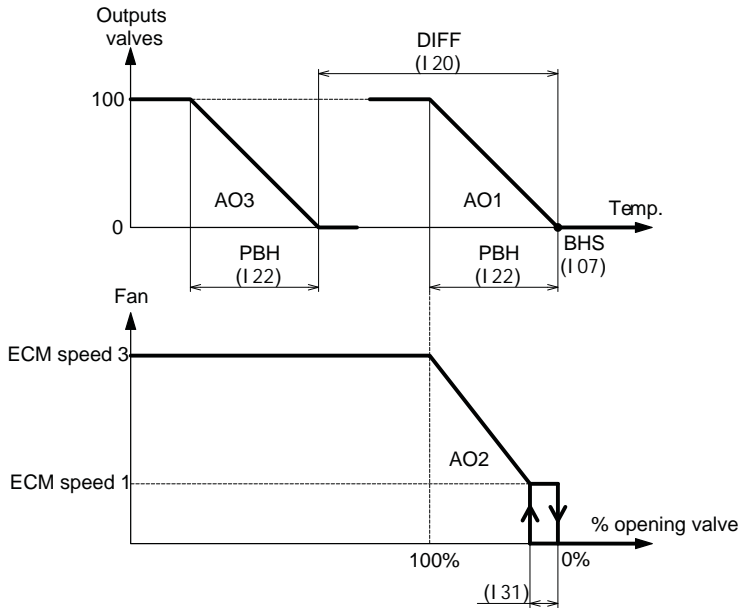

If the operating temperature drops below I 07, the valve starts opening (output **AO1**). Icon turns on.

The valve can be regulated with PI action if the integral time I 24 is non-zero or with only proportional action if I 24=0.

The fan (output **AO2**) starts when the valve reaches the minimum aperture given by parameter I 31, and after the fan start delay I 36 has expired.

The speed increases linearly as the valve opens. Speed 3 is reached when the valve is fully open (see [“EC motor automatic speed control logic with 0..10 V modulating outputs” page 28](#)).

If the temperature drops below I 07 - I 20 the second valve starts opening (output **AO3**) with a proportional action.

The second valve opens completely if the temperature drops below I 07 - I 20 - I 22.

Icon turns off when the valve (output **AO1**) closes again, in which case the fan stops if I 28=0 or 2. The fan maintains speed 1 if I 28=1 or 3.

The fan maintains speed selected manually if I 28=4 or 6.

N.B.: if the minimum thermostat function is active, the thermostat itself must be closed when the valve is in regulation, otherwise the fan will not start.

Wiring diagram

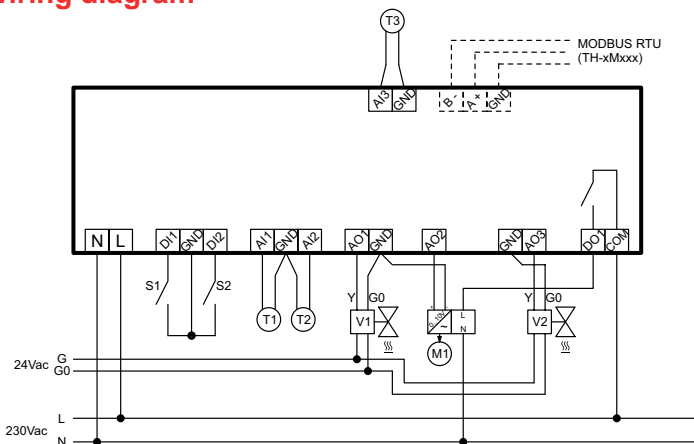

• 2 PIPE HEATING/COOLING mode with AUTOMATIC SEASON CHANGEOVER (M01=2):

The mode is selected automatically by the water sensor. Use a remote sensor for this function. Set parameters M07=1 or M09=1 or M11=1 and set the water sensor's thresholds to define the function with parameters I 15 and I 16. Select the mode of automatic season changeover between the following graphs by parameter I 54.

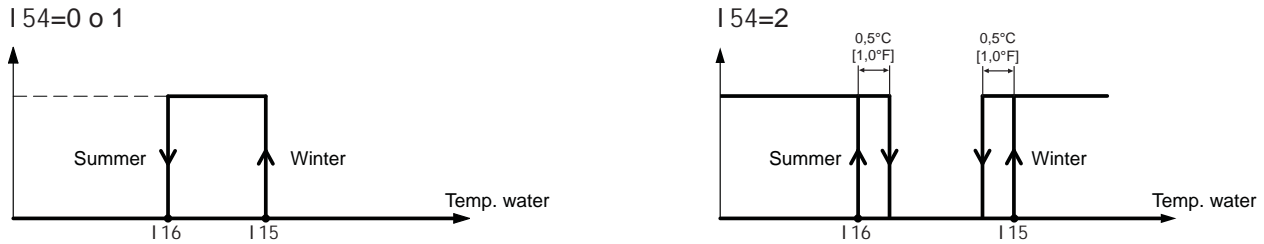

When the unit is turned on, if the water sensor temperature is between I 16 and I 15, see paragraph "12. Automatic season changeover with water sensor (M01=2 or 5)" page 24 for working season definition.

N.B.: if no remote sensor is configured as water sensor for season changeover function, the operating mode is not defined and the regulation does not start.

• 2 PIPE HEATING/COOLING mode with SEASON CHANGEOVER by CONTACT (M01=3):

The season is selected by the position of remote contact **DI1** or **DI2** configured with the "remote contact season changeover" function. Configure one of the digital contacts as indicated in the following table.

M03 (or M05)=0 Remote season changeover contact	M04 (or M06)=	0	1
	Summer		
	Winter		

If the digital contacts are used for other functions, you can use a remote sensor input as "remote contact season changeover" by configuring one of the remote sensors as shown in the table below.

M07 (M09 or M11)=0 Remote season changeover contact	M08 (M10 or M12)=	0	1
	Summer		
	Winter		

N.B.: if no digital contact and no remote sensor are configured as "remote contact season changeover", the operating mode is heating.

• 2 PIPE HEATING/COOLING with SEASON CHANGEOVER by PARAMETER (M01=4):

The season is selected manually (see "MODE button functionality" page 9).

Once you have made the selection, either "HEAT" or "COOL" icon is displayed, depending on the mode.

Heating regulation is controlled as follows for 2 pipe heating/cooling mode (M01=2, 3, 4):

The "HEAT" icon is on to indicate that heating mode is active.

The regulation logic is as follows:

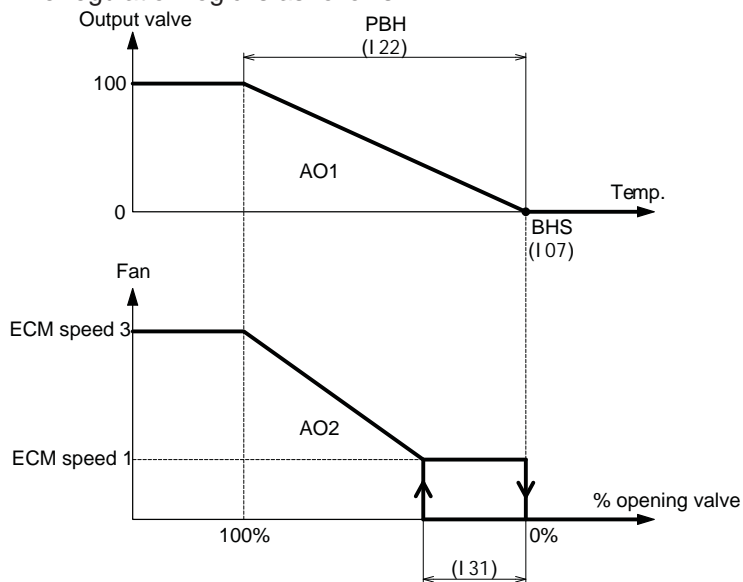

If the operating temperature drops below I 07, the valve starts opening (output **AO1**). Icon turns on.

The valve can be regulated with PI action if the integral time I 24 is non-zero or with only proportional action if I 24=0.

The fan (output **AO2**) starts when the valve reaches the minimum aperture given by parameter I 31, and after the fan start delay I 36 has expired.

The speed increases linearly as the valve opens. Speed 3 is reached when the valve is fully open (see "EC motor automatic speed control logic with 0..10 V modulating outputs" page 28).

Icon turns off when the valve closes again, in which case the fan stops if I 28=0 or 2. The fan maintains speed 1 if I 28=1 or 3.

The fan maintains speed selected manually if I 28=4 or 6. N.B.: if the minimum thermostat function is active, the thermostat itself must be closed when the valve is in regulation, otherwise the fan will not start.

Cooling regulation is controlled as follows for 2 pipe heating/cooling mode (M01=2, 3, 4):

The **"COOL"** icon is on to indicate cooling mode.

The regulation logic is as follows:

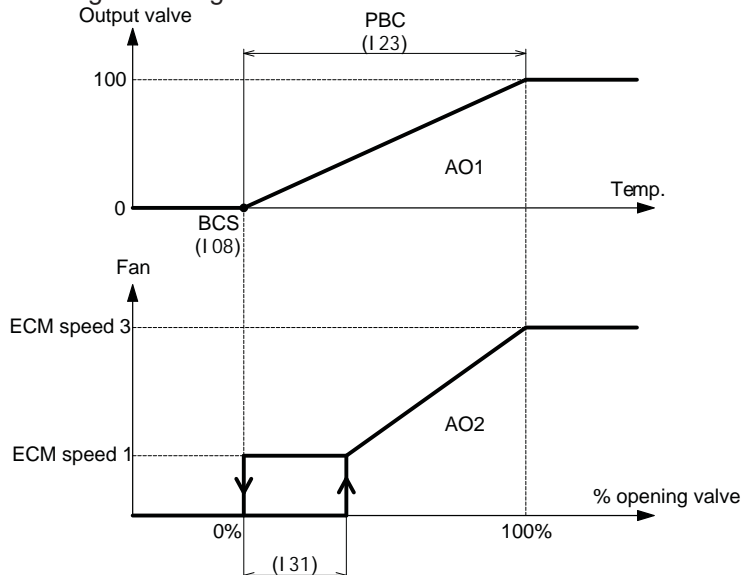

If the operating temperature rises above I 08 the valve starts opening (output **AO1**). Icon turns on.

The valve can be regulated with PI action if the integral time I 24 is non-zero or with only proportional action if I 24=0.

The fan (output **AO2**) starts when the valve reaches the minimum aperture given by parameter I 31, and after the fan start delay I 36 has expired.

The speed increases linearly as the valve opens. Speed 3 is reached when the valve is fully open (see "EC motor automatic speed control logic with 0..10 V modulating outputs" page 28).

Icon turns off when the valve closes again, in which case the fan stops if I 28=0 or 3. The fan maintains speed 1 if I 28=1 or 2. The fan maintains speed selected manually if I 28=4 or 5.

Wiring diagram

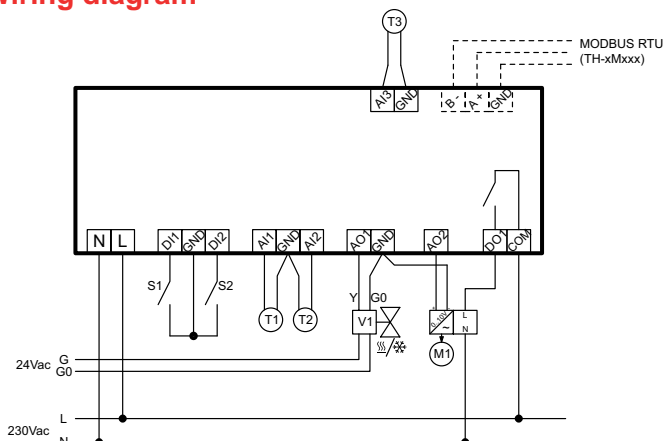

• 2 PIPE HEATING/COOLING + ELECTRIC RESISTANCE mode with AUTOMATIC SEASON CHANGEOVER (M01=5):

The mode is selected automatically by the water sensor. Use a remote sensor for this function. Set parameters M07=1 or M09=1 or M11=1 and set the water sensor's thresholds to define the function with parameters I 15 and I 16. Select the mode of automatic season changeover between the following graphs by parameter I 54.

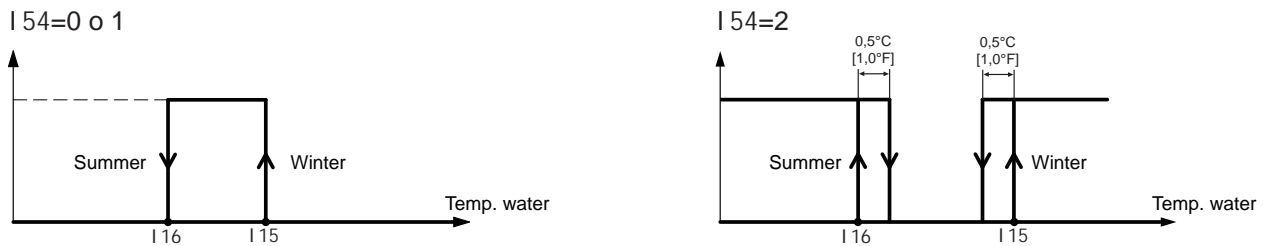

When the unit is turned on, if the water sensor temperature is between I 16 and I 15, see paragraph [“12. Automatic season changeover with water sensor \(M01=2 or 5\)” page 24](#) for working season definition.

N.B.: if no remote sensor is configured as water sensor for season changeover function, the operating mode is not defined and the regulation does not start.

• 2 PIPE HEATING/COOLING + ELECTRIC RESISTANCE mode with SEASON CHANGE-OVER by CONTACT (M01=6):

The season is selected by the position of remote contact **DI1** or **DI2** configured with the “remote contact season changeover” function. Configure one of the digital contacts as shown in the following table.

M03 (or M05)=0 Remote season changeover contact	M04 (or M06)=	0	1
	Summer		
	Winter		

If the digital contacts are used for other functions, you can use a remote sensor input as “remote contact season changeover” by configuring one of the remote sensors as shown in the table.

M07 (M09 or M11)=0 Remote season changeover contact	M08 (M10 or M12)=	0	1
	Summer		
	Winter		

N.B.: if no digital contact and no remote sensor are configured as “remote contact season changeover”, the operating mode is heating.

• **2 PIPE HEATING/COOLING + ELECTRIC RESISTANCE mode with SEASON CHANGEOVER by PARAMETER (M01=7):**

The season is chosen manually (see “*MODE button functionality*” page 9):

Once you have made the selection, either “HEAT” or “COOL” is displayed, depending on the mode.

Heating regulation is controlled as follows for 2 pipe heating/cooling mode (M01=5, 6, 7):

The “HEAT” icon is on to indicate that heating mode is active.

The regulation logic is as follows:

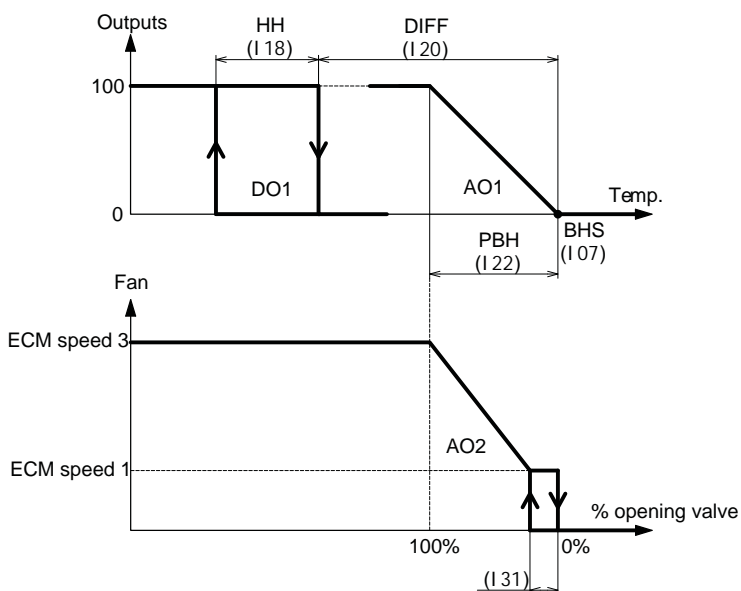



If the operating temperature drops below I 07, the valve starts opening (output **AO1**). Icon  turns on.

The valve can be regulated with PI action if the integral time I 24 is non-zero or with only proportional action if I 24=0.

The fan (output **AO2**) starts when the valve reaches the minimum aperture given by parameter I 31, and after the fan start delay I 36 has expired.

The speed increases linearly as the valve opens. Speed 3 is reached when the valve is fully open (see “*EC motor automatic speed control logic with 0..10 V modulating outputs*” page 28).

If the temperature drops below I 07 - I 20 - I 18 the electric resistance output (**DO1**) is activated and icon  turns on.

If the temperature returns above I 07 - I 20 the electric resistance output is deactivated and icon  turns off.

A timer now starts (parameter I 35) during which the fan cannot be turned off even if the setpoint is reached. Once delay I 35 has expired, the fan can be turned off if necessary.

When the electric resistance turns on, the fan turns on immediately regardless of the ventilation delay set in parameter I 36 and the position of the minimum thermostat (if in use).

Icon  turns off when the valve closes again, in which case the fan stops if I 28=0 or 2. The fan maintains speed 1 if I 28=1 or 3.

The fan maintains speed selected manually if I 28=4 or 6.

N.B.: if the minimum thermostat function is active, the thermostat itself must be closed when the valve is in regulation, otherwise the fan will not start. If, on the other hand, the electric resistance turns on, the fan starts immediately regardless of the position of the minimum thermostat.

Cooling regulation is controlled as follows for 2 pipe heating/cooling mode (M01=5, 6, 7):

In half seasons, when cooling is still active, certain days may be colder than others. While keep cooling mode active, you can enable an electric resistance to heat the room when its temperature is too low.

To enable this function, set M15=1.

To disable it, set M15=0.

- Operation without half season function (M15=0):

The "COOL" icon is on to indicate cooling mode.

The regulation logic is as follows:

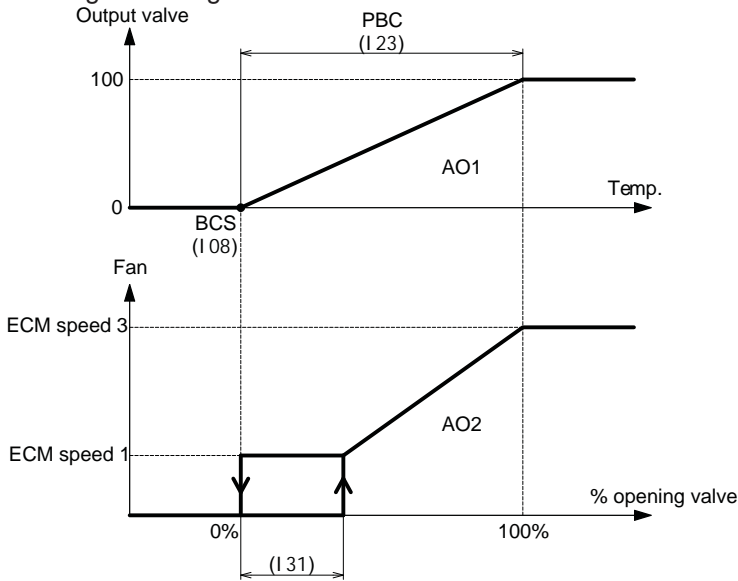

If the operating temperature rises above I08 the valve starts opening (output **AO1**). Icon ❄️ turns on.

The valve can be regulated with PI action if the integral time I24 is non-zero or with only proportional action if I24=0.

The fan (output **AO2**) starts when the valve reaches the minimum aperture given by parameter I31, and after the fan start delay I36 has expired.

The speed increases linearly as the valve opens. Speed 3 is reached when the valve is fully open (see "EC motor automatic speed control logic with 0..10 V modulating outputs" page 28).

Icon ❄️ turns off when the valve closes again, in which case the fan stops if I28=0 or 3. The fan maintains speed 1 if I28=1 or 2. The fan maintains speed selected manually if I28=4 or 5.

The electric resistance is always off in this application.

- Operation with half season function (M15=1):

The "COOL" icon is on to indicate that cooling mode is active.

The regulation logic is as follows:

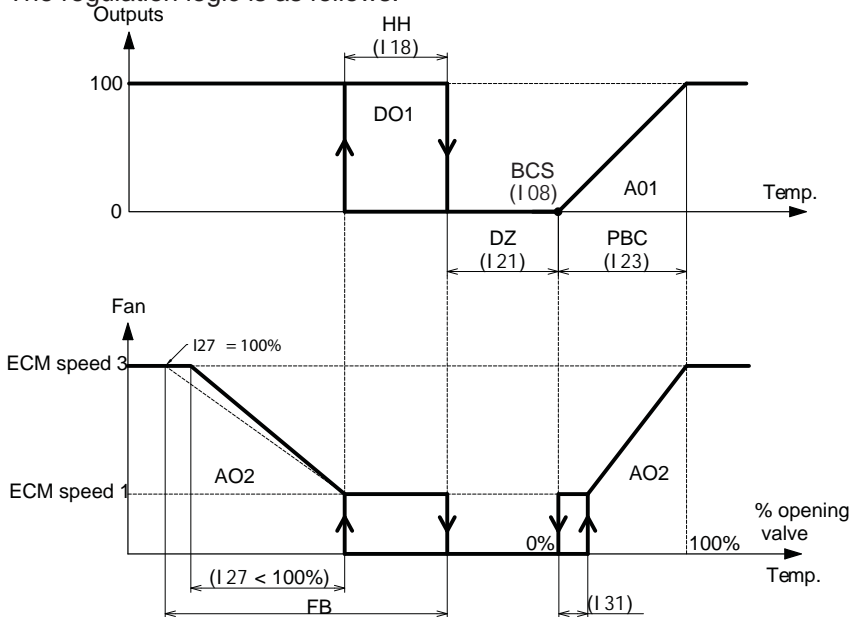

If the operating temperature rises above I08 the valve starts opening (output **AO1**). Icon ❄️ turns on.

The valve can be regulated with PI action if the integral time I24 is non-zero or with only proportional action if I24=0.

The fan (output **AO2**) starts when the valve reaches the minimum aperture given by parameter I31, and after the fan start delay I36 has expired.

The speed increases linearly as the valve opens. Speed 3 is reached when the valve is fully open (see "EC motor automatic speed control logic with 0..10 V modulating outputs" page 28).

Icon ❄️ turns off when the valve closes again, in which case the fan stops if I28=0 or 3. The fan maintains speed 1 if I28=1 or 2. The fan maintains speed selected manually if I28=4 or 5.

If the operating temperature drops below I08 - I21 - I18, relay **DO1** (electric resistance) is activated and the fan starts immediately at speed 1 without considering the activation delay I36. The speed then increases as the operating tempera-

ture decreases until it reaches speed 3 when the operating temperature drops below $I08 - I21 - I18 - [I27 \times (FB - I18)]$.
Icon --- turns on to indicate heating with the electric resistance is active.

If the operating temperature increases to $I08 - I21 - I18$, the speed remains constant at speed 1 until the temperature exceeds $I08 - I21$.

At this point the icon --- turns off and, depending on the value of parameter $I28$, ventilation either stops after delay $I35$ or continues for air recirculation:

if $I28=0$ or 2 , the fan stops after delay $I35$.

if $I28=1$ or 3 , the fan stays on at speed 1.

if $I28=4$ or 6 , the fan stays on at speed selected manually.

Wiring diagram

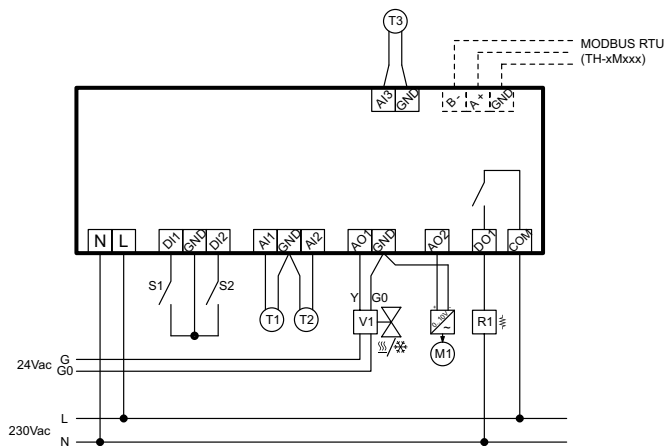

N.B.: only standard EC motors can be used for this application (M14=1).

TH-0xxSx1

• 4 PIPE HEATING/COOLING mode (M01=8)

The mode is selected automatically in relation to the operating temperature (see "11. Regulation sensor(s)" page 24). If the operating temperature is greater than $I09 + (I21 : 2)$ the icon "COOL" turns on to indicate that cooling mode is active.

If the operating temperature is lower than $I09 - (I21 : 2)$ the icon "HEAT" turns on to indicate that heating mode is active. When the unit is turned on, if the operating temperature is in the neutral zone (I21), the mode is set to heating.

The valves can be controlled with PI action if the integral time I24 is non-zero, or with proportional action only if I24=0.

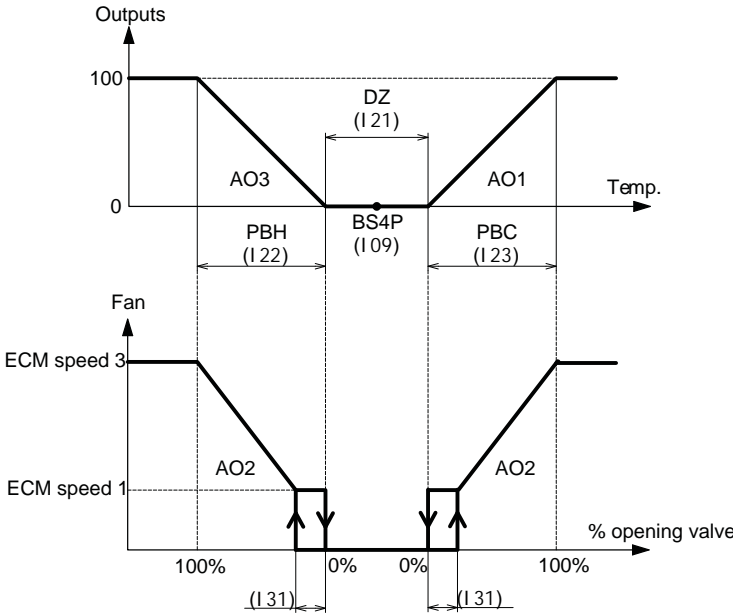

If the operating temperature drops below $I09 - (I21 : 2)$ the heating valve starts to open (output **AO3**). Icon ☀ turns on.

The fan (output **AO2**) starts when the valve reaches the minimum aperture given by parameter I31, and after the fan start delay I36 has expired.

The speed increases linearly as the valve opens. Speed 3 is reached when the valve is fully open (see "EC motor automatic speed control logic with 0..10 V modulating outputs" page 28).

Icon ☀ turns off if the heating valve closes again, at which point the fan stops if I28=0 or 2. The fan maintains speed 1 if I28=1 or 3.

The fan maintains speed selected manually if I28=4 or 6.

N.B.: if the minimum thermostat function is active, the thermostat itself must be closed when the valve is in regulation, otherwise the fan will not start.

If the operating temperature rises above $I09 + (I21 : 2)$ the cooling valve starts to open (output **AO1**). Icon ❄ turns on. The fan (output **AO2**) starts when the valve reaches the minimum aperture given by parameter I31, and after the fan start delay I36 has expired.

The speed increases linearly as the valve opens. Speed 3 is reached when the valve is fully open (see "EC motor automatic speed control logic with 0..10 V modulating outputs" page 28).

Icon ❄ turns off when the valve closes again, in which case the fan stops if I28=0 or 3. The fan maintains speed 1 if I28=1 or 2. The fan maintains speed selected manually if I28=4 or 5.

Wiring diagram

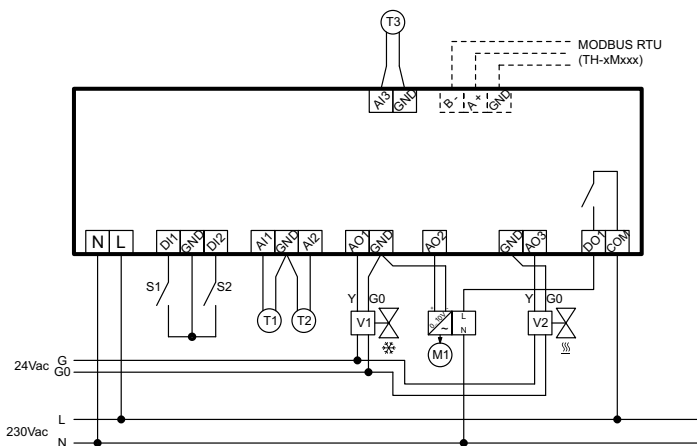

• 4 PIPE HEATING/COOLING mode + ELECTRIC RESISTANCE (M01=9)

The mode is selected automatically in relation to the operating temperature (see "11. Regulation sensor(s)" page 24).

If the operating temperature is greater than $I09 + (I21 : 2)$ the icon "COOL" turns on to indicate that cooling mode is active. If the operating temperature is lower than $I09 - (I21 : 2)$ the icon "HEAT" turns on to indicate that heating mode is active.

When the unit is turned on, if the operating temperature is in the neutral zone (I21), the mode is set to heating.

The valves can be controlled with PI action if the integral time I24 is non-zero, or with proportional action only if I24=0.

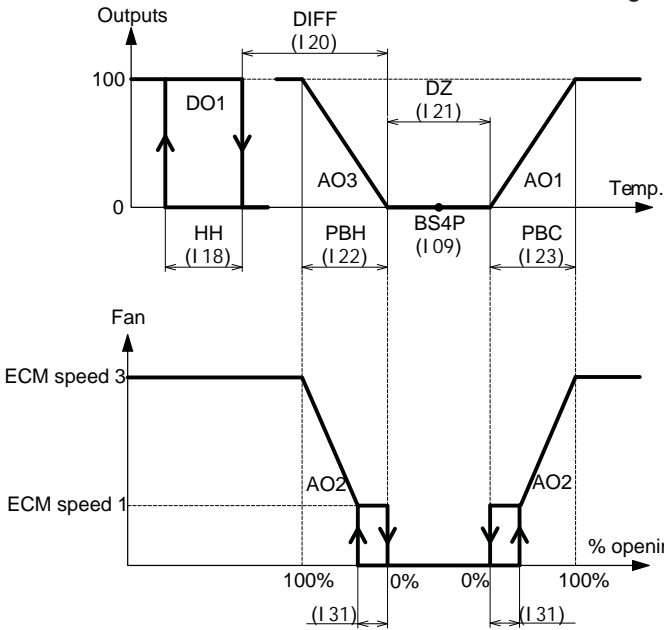

If the operating temperature drops below $I09 - (I21 : 2)$ the heating valve starts to open (output AO3). Icon turns on.

The fan (output AO2) starts when the valve reaches the minimum aperture given by parameter I31, and after the fan start delay I36 has expired.

The speed increases linearly as the valve opens. Speed 3 is reached when the valve is fully open (see "EC motor automatic speed control logic with 0..10 V modulating outputs" page 28).

If the temperature drops below $I09 - (I21 : 2) - I20 - I18$, the electric resistance output (DO1) is activated and the icon turns on.

If the temperature returns to above $I09 - (I21 : 2) - I20$ the electric resistance output is deactivated and icon turns off.

A timer now starts (parameter I35) during which the fan cannot be turned off even if the setpoint is reached. Once delay I35 has expired, the fan can be turned off if necessary.

When the electric resistance turns on, the fan turns on immediately regardless of the ventilation delay set in parameter I36 and the position of the minimum thermostat (if in use).

Icon turns off when the valve closes again, in which case the fan stops if I28=0 or 2. The fan maintains speed 1 if I28=1 or 3.

The fan maintains speed selected manually if I28=4 or 6.

N.B.: if the minimum thermostat function is active, the thermostat itself must be closed when the valve is in regulation, otherwise the fan will not start. If, on the other hand, the electric resistance turns on, the fan starts immediately regardless of the position of the minimum thermostat.

If the operating temperature rises above $I09 + (I21 : 2)$ the cooling valve starts to open (output AO1). Icon turns on. The fan (output AO2) starts when the valve reaches the minimum aperture given by parameter I31, and after the fan start delay I36 has expired.

The speed increases linearly as the valve opens. Speed 3 is reached when the valve is fully open (see "EC motor automatic speed control logic with 0..10 V modulating outputs" page 28).

Icon turns off when the valve closes again, in which case the fan stops if I28=0 or 3. The fan maintains speed 1 if I28=1 or 2. The fan maintains speed selected manually if I28=4 or 5.

Wiring diagram

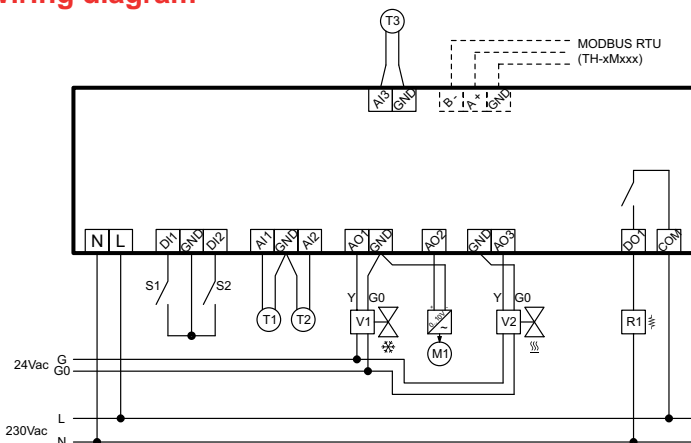

N.B.: only standard EC motors can be used for this application (M14=1).

TH-0xxSx1

• **COOLING mode (M01=10)**

The “COOL” icon is on to indicate cooling mode.

The regulation uses the following automatic speed control logic:

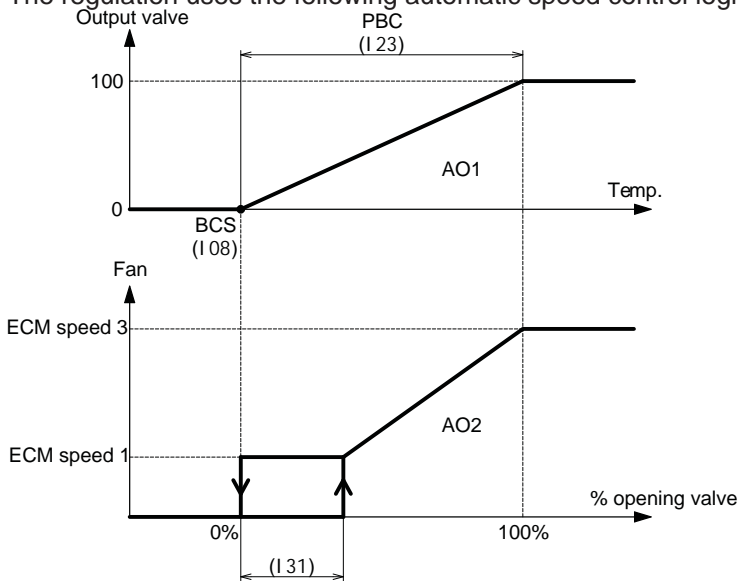

If the operating temperature rises above I08 the valve starts opening (output **AO1**). Icon ❄️ turns on.

The valve can be regulated with PI action if the integral time I24 is non-zero or with only proportional action if I24=0. The fan (output **AO2**) starts when the valve reaches the minimum aperture given by parameter I31, and after the fan start delay I36 has expired.

The speed increases linearly as the valve opens. Speed 3 is reached when the valve is fully open (see “EC motor automatic speed control logic with 0..10 V modulating outputs” page 28).

Icon ❄️ turns off when the valve closes again, in which case the fan stops if I28=0 or 3. The fan maintains speed 1 if I28=1 or 2. The fan maintains speed selected manually if I28=4 or 5.

Wiring diagram

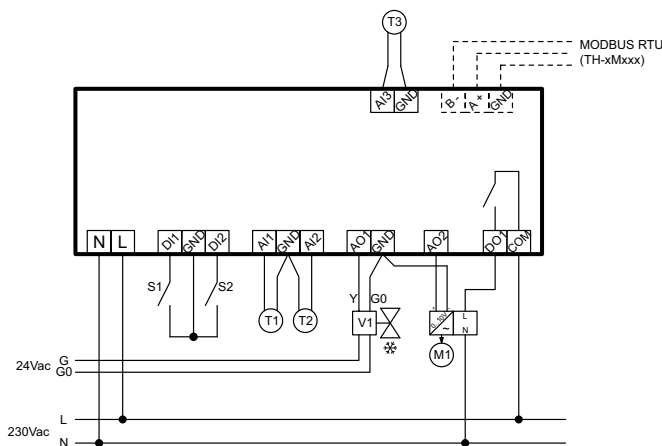

TH-0xxSx1

• **COOLING/COOLING mode (M01=11)**

The “COOL” icon is on to indicate cooling mode.

The regulation logic is as follows:

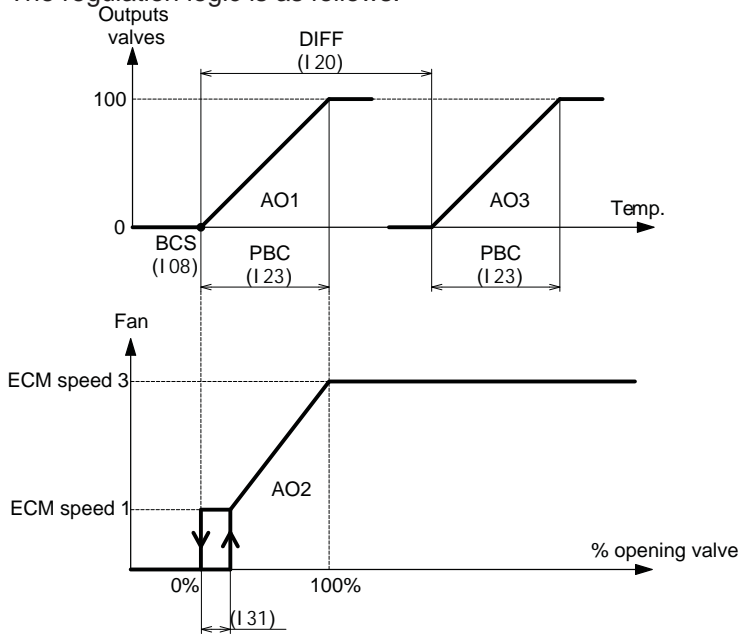

If the operating temperature rises above I 08 the valve starts opening (output **AO1**). Icon ❄ turns on.
 The valve can be regulated with PI action if the integral time I 24 is non-zero or with only proportional action if I 24=0.
 The fan (output **AO2**) starts when the valve reaches the minimum aperture given by parameter I 31, and after the fan start delay I 36 has expired.
 The speed increases linearly as the valve opens. Speed 3 is reached when the valve is fully open (see “EC motor automatic speed control logic with 0..10 V modulating outputs” page 28).
 If the temperature rises above I 08 + I 20, the second valve starts opening (output **AO3**) with proportional action.
 The second valve opens completely if the temperature rises above I 08 + I 20 + I 23.

Icon ❄ turns off when the valve (output **AO1**) closes again, in which case the fan stops if I 28=0 or 3. The fan maintains speed 1 if I 28=1 or 2. The fan maintains speed selected manually if I 28=4 or 5.

Wiring diagram

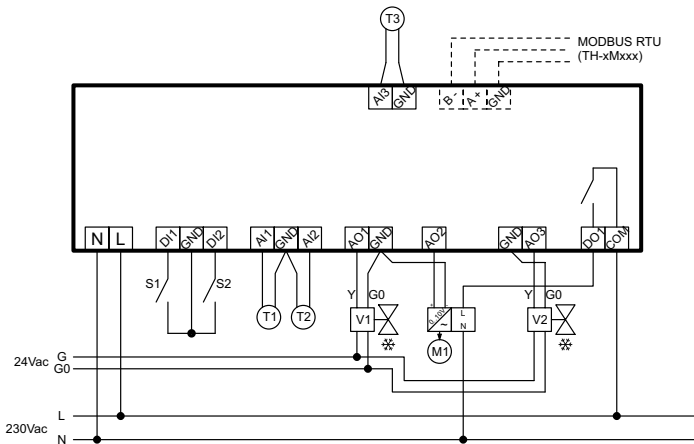

30. Regulation (Model TH-1xxSx1)

All the graphics below refer to automatic speed control.

• HEATING mode (M01=0)

The "HEAT" icon is on to indicate that heating mode is active.

The regulation logic is as follows:

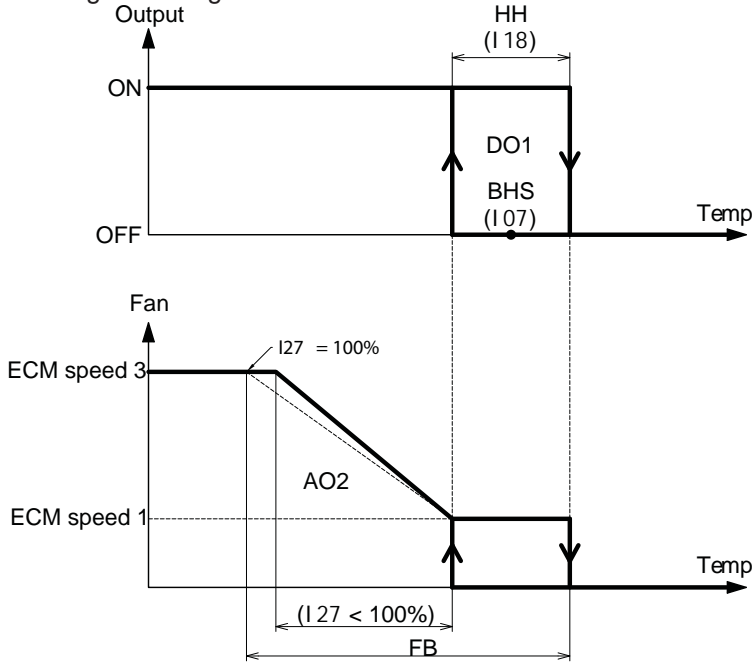

- Operation with M02=0 or 2 (digital output **DO1** does not control an electric resistance).

If the operating temperature drops below $I07 - (I18 : 2)$ relay **DO1** is activated and the fan starts (output **AO2**) at speed 1 after the startup delay I36 has expired, after which the speed increases as the operating temperature falls, arriving at speed 3 when the operating temperature is below $I07 - (I18 : 2) - [I27 \times (FB - I18)]$. The icon turns on to indicate that heating is active.

If the operating temperature increases to $I07 - (I18 : 2)$ the speed remains constant at speed 1 until the operating temperature rises above $I07 + (I18 : 2)$.

At this point, icon turns off and, depending on the value of parameter I28, the fan either stops or continues running:

if I28=0 or 2, the fan stops,

if I28=1 or 3, the fan stays on at speed 1.

if I28=4 or 6, the fan stays on at speed selected manually.

- Operation with M02=1 or 3 (digital output **DO1** controls an electric resistance).

If the operating temperature drops below $I07 - (I18 : 2)$ relay **DO1** is activated and the fan starts immediately at speed 1 regardless of the startup delay I36. The speed then increases as the operating temperature falls, arriving at speed 3 when the operating temperature drops below $I07 - (I18 : 2) - [I27 \times (FB - I18)]$.

Icons and turn on to indicate heating with electric resistance.

If the operating temperature increases to $I07 - (I18 : 2)$ the speed remains constant at speed 1 until the operating temperature rises above $I07 + (I18 : 2)$.

At this point, icons and turn off and, depending on the value of I28, the fan either stops after a delay I35 or stays on for air recirculation:

if I28=0 or 2, the fan stops after delay I35.

if I28=1 or 3, the fan stays on at speed 1.

if I28=4 or 6, the fan stays on at speed selected manually.

N.B.: if the minimum thermostat function is active, the thermostat itself must be closed when the valve is in regulation, otherwise the fan will not start. If, on the other hand, the electric resistance turns on, the fan starts immediately regardless of the position of the minimum thermostat.

Wiring diagram

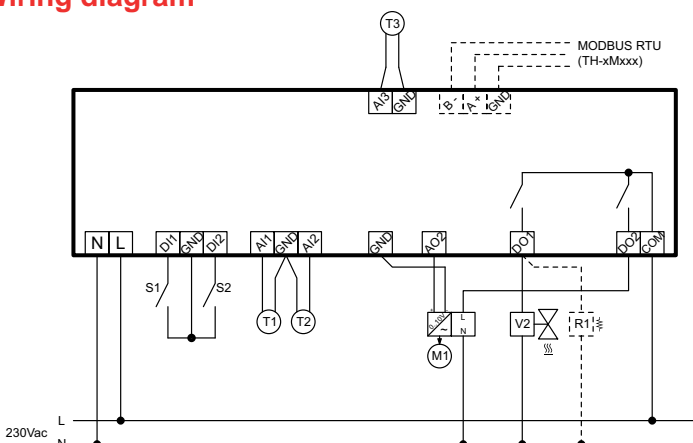

TH-1xxSx1

• HEATING/HEATING mode (MO1=1)

The "HEAT" icon is on to indicate that heating mode is active.

The regulation logic is as follows:

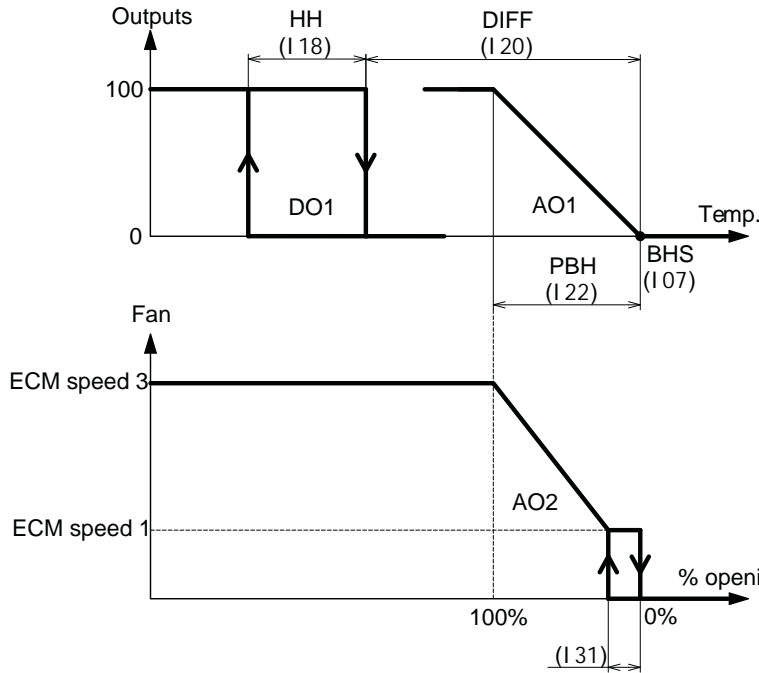

If the operating temperature drops below I07, the valve starts opening (output **AO1**). Icon turns on.

The valve can be regulated with PI action if the integral time I24 is non-zero or with only proportional action if I24=0.

The fan (output **AO2**) starts when the valve reaches the minimum aperture given by parameter I31, and after the fan start delay I36 has expired.

The speed increases linearly as the valve opens. Speed 3 is reached when the valve is fully open (see "EC motor automatic speed control logic with 0..10 V modulating outputs" page 28).

If the temperature drops below I07 - I20 - I18, the electric resistance output (**DO1**) is activated and icon turns on.

If the temperature returns above I07 - I20 the electric resistance output is deactivated and icon turns off.

A timer now starts (parameter I35) during which the fan cannot be turned off even if the setpoint is reached. Once delay I35 has expired, the fan can be turned off if necessary.

When the electric resistance turns on, the fan turns on immediately regardless of the ventilation delay set in parameter I36 and the position of the minimum thermostat (if in use).

Icon turns off when the valve closes again, in which case the fan stops if I28=0 or 2. The fan maintains speed 1 if I28=1 or 3.

The fan maintains speed selected manually if I28=4 or 6.

N.B.: if the minimum thermostat function is active, the thermostat itself must be closed when the valve is in regulation, otherwise the fan will not start. If, on the other hand, the electric resistance turns on, the fan starts immediately regardless of the position of the minimum thermostat.

Wiring diagram

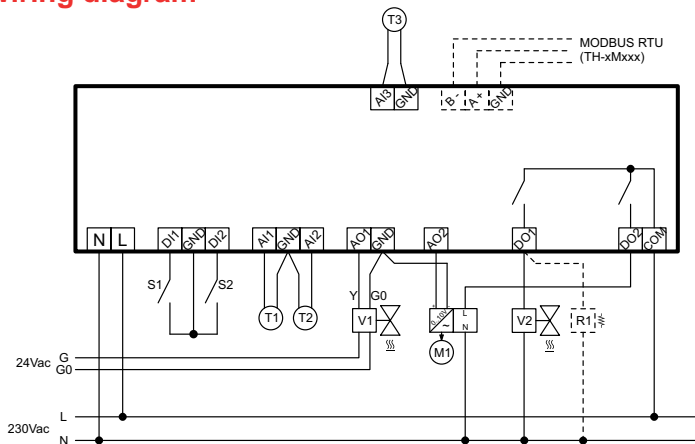

TH-1xxSx1

• 2 PIPE HEATING/COOLING mode with AUTOMATIC SEASON CHANGEOVER (M01=2):

The mode is selected automatically by the water sensor. Use a remote sensor for this function. Set parameters M07=1 or M09=1 or M11=1 and set the water sensor's thresholds to define the function with parameters I 15 and I 16. Select the mode of automatic season changeover between the following graphs by parameter I 54.

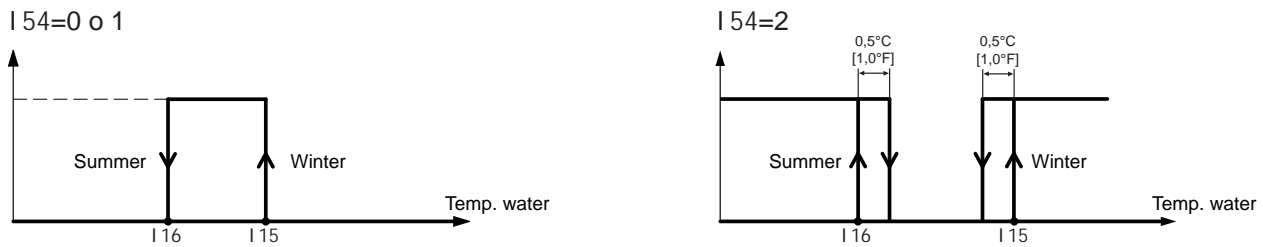

When the unit is turned on, if the water sensor temperature is between I 16 and I 15, see paragraph [“12. Automatic season changeover with water sensor \(M01=2 or 5\)” page 24](#) for working season definition.

N.B.: if no remote sensor is configured as water sensor for season changeover function, the operating mode is not defined and the regulation does not start.

• 2 PIPE HEATING/COOLING mode with SEASON CHANGEOVER by CONTACT (M01=3):

The season is selected by the position of remote contact **DI1** or **DI2** configured with the “remote contact season changeover” function. Configure one of the digital contacts as shown in the following table.

M03 (or M05)=0 Remote season changeover contact	M04 (or M06)=	0	1
	Summer		
	Winter		

If the digital contacts are used for other functions, you can use a remote sensor input as “remote contact season changeover” by configuring one of the remote sensors as shown in the table.

M07 (M09 or M11)=0 Remote season changeover contact	M08 (M10 or M12)=	0	1
	Summer		
	Winter		

N.B.: if no digital contact and no remote sensor are configured as “remote contact season changeover”, the operating mode is heating.

• 2 PIPE HEATING/COOLING with SEASON CHANGEOVER by PARAMETER (M01=4):

The season is selected manually (see [“MODE button functionality” page 9](#)).

Once you have made the selection, either “**HEAT**” or “**COOL**” is displayed, depending on the mode.

Heating regulation is controlled as follows for 2 pipe heating/cooling mode (M01=2, 3, 4):

The “**HEAT**” icon is on to indicate that heating mode is active.

The regulation logic is as follows:

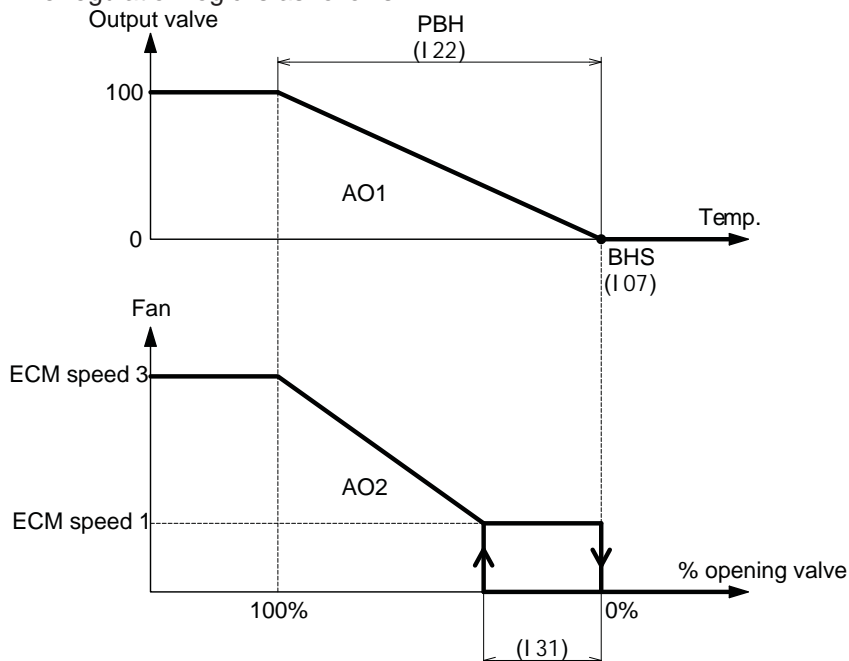

If the operating temperature drops below I07, the valve starts opening (output **AO1**). Icon turns on.

The valve can be regulated with PI action if the integral time I24 is non-zero or with only proportional action if I24=0.

The fan (output **AO2**) starts when the valve reaches the minimum aperture given by parameter I31, and after the fan start delay I36 has expired.

The speed increases linearly as the valve opens. Speed 3 is reached when the valve is fully open (see "EC motor automatic speed control logic with 0..10 V modulating outputs" page 28).

Icon turns off when the valve closes again, in which case the fan stops if I28=0 or 2. The fan maintains speed 1 if I28=1 or 3.

The fan maintains speed selected manually if I28=4 or 6.

N.B.: if the minimum thermostat function is active, the thermostat itself must be closed when the valve is in regulation, otherwise the fan will not start.

Cooling regulation is controlled as follows for 2 pipe heating/cooling mode (M01=2, 3, 4):

The **"COOL"** icon is on to indicate cooling mode.

The regulation logic is as follows:

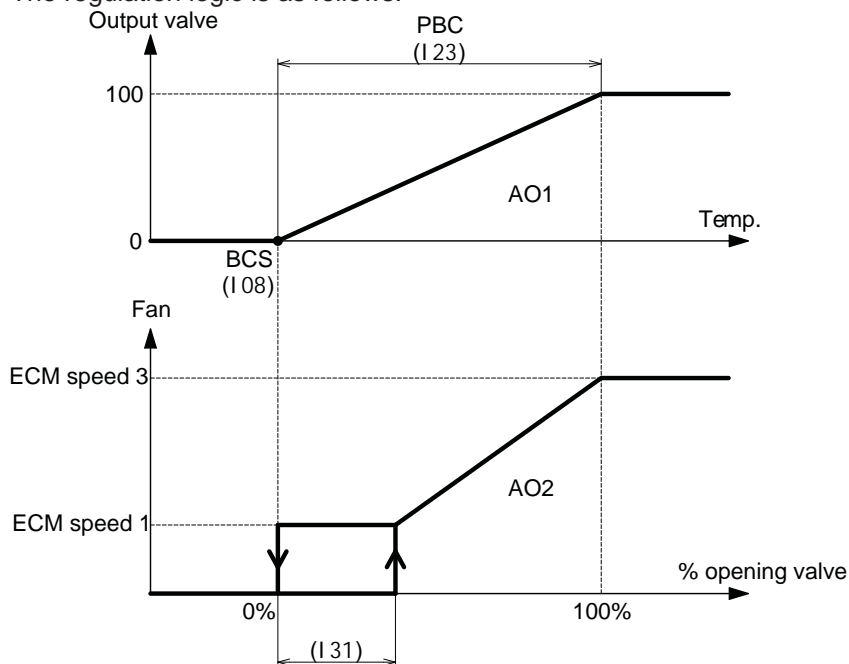

If the operating temperature rises above I08 the valve starts opening (output **AO1**). Icon turns on.

The valve can be regulated with PI action if the integral time I24 is non-zero or with only proportional action if I24=0.

The fan (output **AO2**) starts when the valve reaches the minimum aperture given by parameter I31, and after the fan start delay I36 has expired.

The speed increases linearly as the valve opens. Speed 3 is reached when the valve is fully open (see "EC motor automatic speed control logic with 0..10 V modulating outputs" page 28).

Icon turns off when the valve closes again, in which case the fan stops if I28=0 or 3. The fan maintains speed 1 if I28=1 or 2. The fan maintains speed selected manually if I28=4 or 5.

Wiring diagram

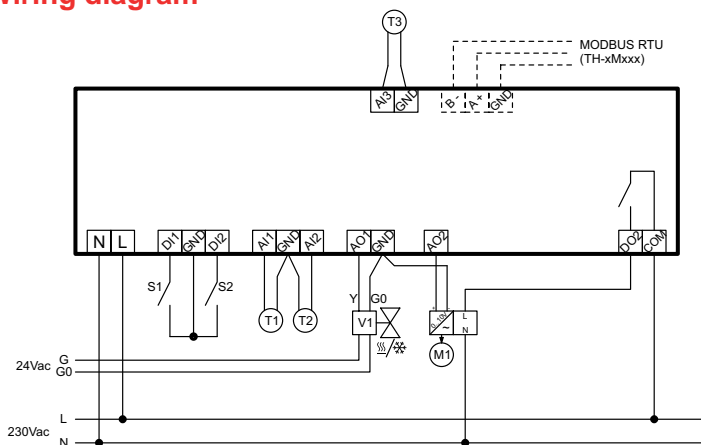

TH-1xxSx1

• **2 PIPE HEATING/COOLING + ELECTRIC RESISTANCE mode with AUTOMATIC SEASON CHANGEOVER (M01=5):**

The mode is selected automatically by the water sensor. Use a remote sensor for this function. Set parameters M07=1 or M09=1 or M11=1 and set the water sensor's thresholds to define the function with parameters I 15 and I 16. Select the mode of automatic season changeover between the following graphs by parameter I 54.

I 54=0 o 1

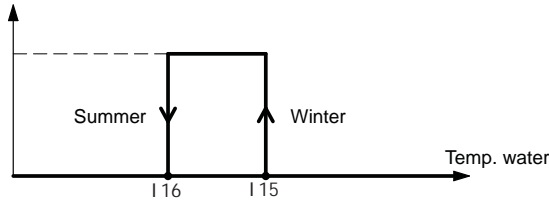

I 54=2

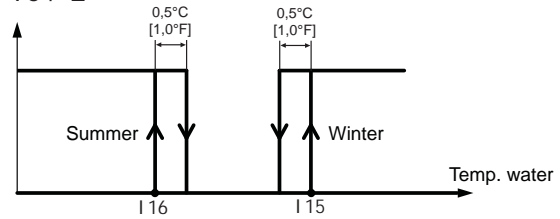

When the unit is turned on, if the water sensor temperature is between I 16 and I 15, see paragraph [“12. Automatic season changeover with water sensor \(M01=2 or 5\)” page 24](#) for working season definition.

N.B.: if no remote sensor is configured as water sensor for season changeover function, the operating mode is not defined and the regulation does not start.

• **2 PIPE HEATING/COOLING + ELECTRIC RESISTANCE mode with SEASON CHANGEOVER by CONTACT (M01=6):**

The season is selected by the position of remote contact **DI1** or **DI2** configured with the “remote contact season changeover” function. Configure one of the digital contacts as shown in the following table.

M03 (or M05)=0 Remote season changeover contact	M04 (or M06)=	0	1
	Summer		
Winter			

If the digital contacts are used for other functions, you can use a remote sensor input as “remote contact season changeover” by configuring one of the remote sensors as shown in the table.

M07 (M09 or M11)=0 Remote season changeover contact	M08 (M10 or M12)=	0	1
	Summer		
Winter			

N.B.: if no digital contact and no remote sensor are configured as “remote contact season changeover”, the operating mode is heating.

• **2 PIPE HEATING/COOLING + ELECTRIC RESISTANCE mode with SEASON CHANGEOVER by PARAMETER (M01=7):**

The season is chosen manually (see [“MODE button functionality” page 9](#)):

Once you have made the selection, either “**HEAT**” or “**COOL**” is displayed, depending on the mode.

Heating regulation is controlled as follows for 2 pipe heating/cooling mode (M01=5, 6, 7):

The “**HEAT**” icon is on to indicate that heating mode is active.

The regulation logic is as follows:

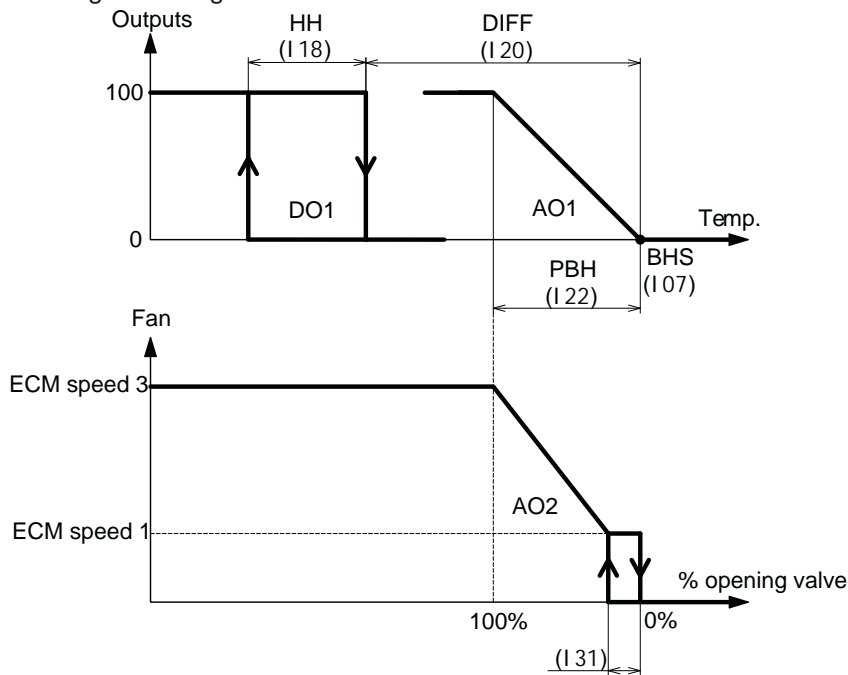



If the operating temperature drops below $I07$, the valve starts opening (output **AO1**). Icon  turns on.

The valve can be regulated with PI action if the integral time $I24$ is non-zero or with only proportional action if $I24=0$.

The fan (output **AO2**) starts when the valve reaches the minimum aperture given by parameter $I31$, and after the fan start delay $I36$ has expired.

The speed increases linearly as the valve opens. Speed 3 is reached when the valve is fully open (see "EC motor automatic speed control logic with 0..10 V modulating outputs" page 28).

If the temperature drops below $I07 - I20 - I18$, the electric resistance output (**DO1**) is activated and icon  turns on.

If the temperature returns above $I07 - I20$, the electric resistance output is deactivated and icon  turns off.

A timer now starts (parameter $I35$) during which the fan cannot be turned off even if the setpoint

is reached. Once delay $I35$ has expired, the fan can be turned off if necessary.

When the electric resistance turns on, the fan turns on immediately regardless of the ventilation delay set in parameter $I36$ and the position of the minimum thermostat (if in use).

Icon  turns off when the valve closes again, in which case the fan stops if $I28=0$ or 2. The fan maintains speed 1 if $I28=1$ or 3.

The fan maintains speed selected manually if $I28=4$ or 6.

N.B.: if the minimum thermostat function is active, the thermostat itself must be closed when the valve is in regulation, otherwise the fan will not start. If, on the other hand, the electric resistance turns on, the fan starts immediately regardless of the position of the minimum thermostat.

Cooling regulation is controlled as follows for 2 pipe heating/cooling mode ($M01=5, 6, 7$):

In half seasons, when cooling is still active, certain days may be colder than others. While keep cooling mode active, you can enable an electric resistance to heat the room when its temperature is too low.

To enable this function, set $M15=1$.

To disable it, set $M15=0$.

- Operation without half season function ($M15=0$):

The **"COOL"** icon is on to indicate cooling mode.

The regulation logic is as follows:

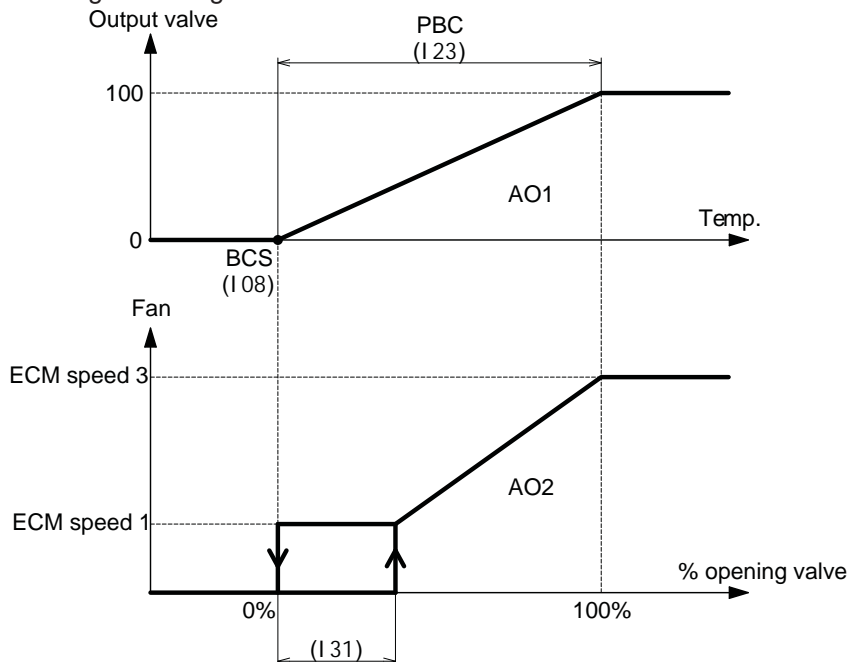

If the operating temperature rises above $I08$ the valve starts opening (output **AO1**). Icon  turns on.

The valve can be regulated with PI action if the integral time $I24$ is non-zero or with only proportional action if $I24=0$.

The fan (output **AO2**) starts when the valve reaches the minimum aperture given by parameter $I31$, and after the fan start delay $I36$ has expired.

The speed increases linearly as the valve opens. Speed 3 is reached when the valve is fully open (see "EC motor automatic speed control logic with 0..10 V modulating outputs" page 28).

Icon  turns off when the valve closes again, in which case the fan stops if $I28=0$ or 3. The fan maintains speed 1 if $I28=1$ or 2.

The fan maintains speed selected manually if $I28=4$ or 5.

The electric resistance is always off in this application.

- Operation with half season function (M15=1):
The "COOL" icon is on to indicate that cooling mode is active.

The regulation logic is as follows:

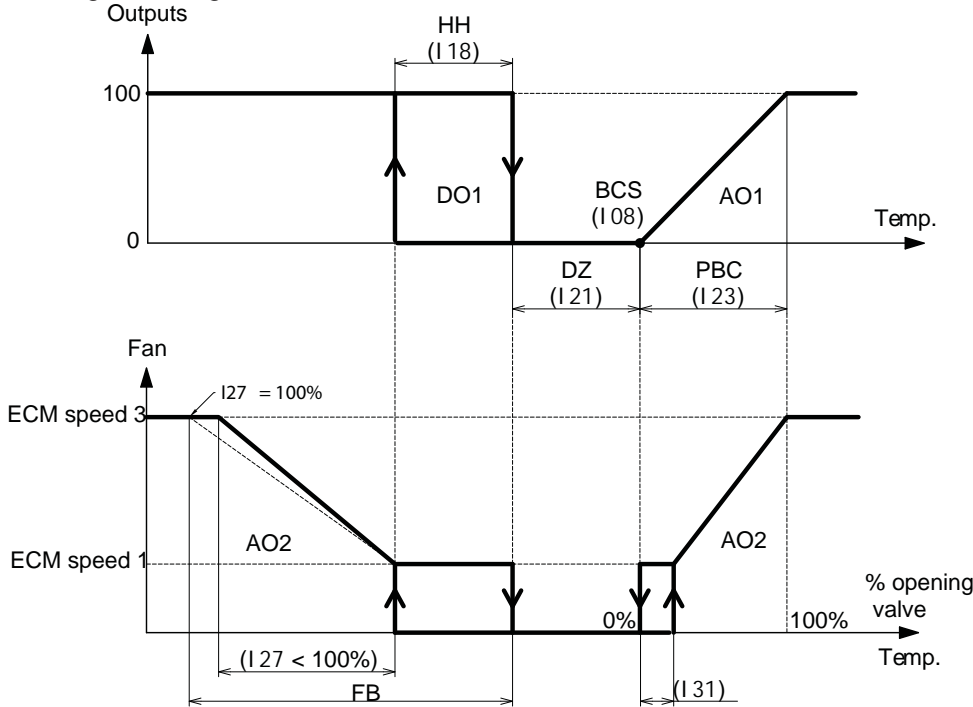

If the operating temperature rises above I08 the valve starts opening (output **AO1**). Icon ❄️ turns on. The valve can be regulated with PI action if the integral time I24 is non-zero or with only proportional action if I24=0.

The fan (output **AO2**) starts when the valve reaches the minimum aperture given by parameter I31, and after the fan start delay I36 has expired.

The speed increases linearly as the valve opens. Speed 3 is reached when the valve is fully open (see "EC motor automatic speed control logic with 0..10 V modulating outputs" page 28).

Icon ❄️ turns off when the valve closes again, in which case the fan stops if I28=0 or 3. The fan maintains speed 1 if I28=1 or 2.

The fan maintains speed selected

manually if I28=4 or 5.

If the operating temperature drops below I08 - I21 - I18, relay **DO1** (electric resistance) is activated and the fan starts immediately at speed 1 without considering the activation delay I36. The speed then increases as the operating temperature decreases until it reaches speed 3 when the operating temperature drops below I08 - I21 - I18 - [I27 x (FB - I18)]. Icon 🔥 turns on to indicate heating with the electric resistance is active.

If the operating temperature increases to I08 - I21 - I18, the speed remains constant at speed 1 until the temperature exceeds I08 - I21.

At this point the icon 🔥 turns off and, depending on the value of parameter I28, ventilation either stops after delay I35 or continues for air recirculation:

if I28=0 or 2, the fan stops after delay I35.

if I28=1 or 3, the fan stays on at speed 1.

if I28=4 or 6, the fan stays on at speed selected manually.

Wiring diagram

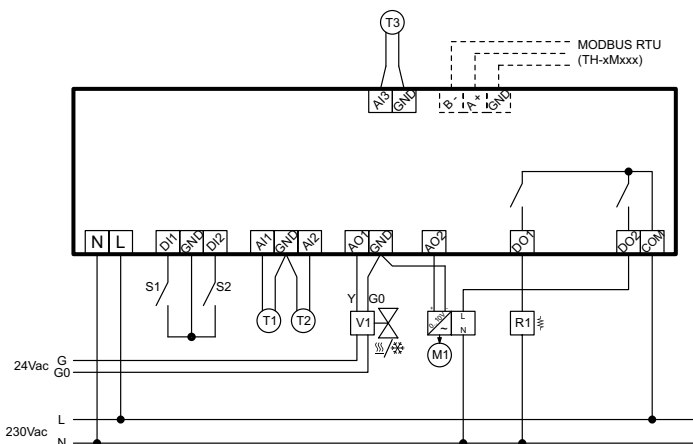

TH-1xxSx1

• **4 PIPE HEATING/COOLING mode (M01=8)**

The mode is selected automatically in relation to the operating temperature (see "11. Regulation sensor(s)" page 24). If the operating temperature is greater than $109 + (121 : 2)$ the icon "COOL" turns on to indicate that cooling mode is active.

If the operating temperature is lower than $109 - (121 : 2)$ the icon "HEAT" turns on to indicate that heating mode is active. When the unit is turned on, if the operating temperature is in the neutral zone (121), the mode is set to heating.

The cooling valve can be regulated with PI action if the integral time I24 is non-zero, or with proportional action only if I24=0.

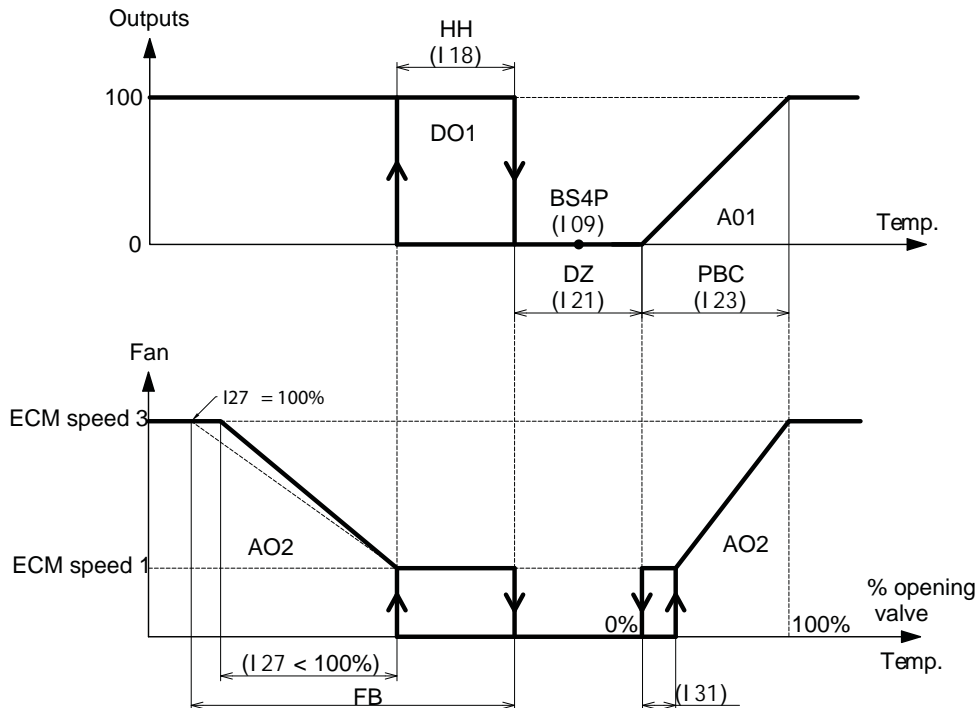

- Operation with M02=0 or 2 (digital output **DO1** does not control an electric resistance).

If the operating temperature drops below $109 - (121 : 2) - I18$, relay **DO1** is activated and the fan starts (output **A02**) at speed 1, after startup delay I36. The speed then increases as the operating temperature falls, arriving at speed 3 when the temperature drops below $109 - (121 : 2) - I18 - [I27 \times (FB - I18)]$.

The icon turns on to indicate that heating mode is active.

If the operating temperature increases to $109 - (121 : 2) - I18$ the speed remains constant at speed 1 until the operating temperature exceeds $109 - (121 : 2)$.

At this point, icon turns off and, depending on the value of parameter I28, the fan either stops or continues

running:

if I28=0 or 2, the fan stops,

if I28=1 or 3, the fan stays on at speed 1.

if I28=4 or 6, the fan stays on at speed selected manually.

- Operation with M02=1 or 3 (digital output **DO1** controls an electric resistance).

If the operating temperature drops below $109 - (121 : 2) - I18$ relay **DO1** is activated and the fan starts immediately at speed 1, regardless of the startup delay I36. The speed then increases as the operating temperature falls, arriving at speed 3 when the temperature drops below $109 - (121 : 2) - I18 - [I27 \times (FB - I18)]$.

Icons and turn on to indicate heating with electric resistance.

If the operating temperature increases to $109 - (121 : 2) - I18$ the speed remains constant at speed 1 until the operating temperature exceeds $109 - (121 : 2)$.

At this point, icons and turn off and, depending on the value of I28, the fan either stops after a delay I35 or stays on for air recirculation:

if I28=0 or 2, the fan stops after delay I35.

if I28=1 or 3, the fan stays on at speed 1.

if I28=4 or 6, the fan stays on at speed selected manually.

N.B.: if the minimum thermostat function is active, the thermostat itself must be closed when the valve is in regulation, otherwise the fan will not start. If, on the other hand, the electric resistance turns on, the fan starts immediately regardless of the position of the minimum thermostat.

If the operating temperature rises above $I 09 + (I 21 : 2)$ the cooling valve starts to open (output **AO1**). Icon  turns on. The fan (output **AO2**) starts when the valve reaches the minimum aperture given by parameter I 31, and after the fan start delay I 36 has expired.

The speed increases linearly as the valve opens. Speed 3 is reached when the valve is fully open (see [“EC motor automatic speed control logic with 0..10 V modulating outputs” page 28](#)).

Icon  turns off when the valve closes again, in which case the fan stops if I 28=0 or 3. The fan maintains speed 1 if I 28=1 or 2. The fan maintains speed selected manually if I 28=4 or 5.

Wiring diagram

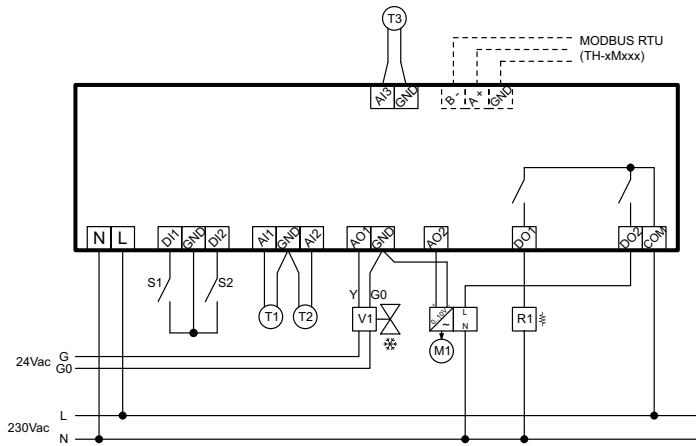

• 4 PIPE HEATING/COOLING mode + ELECTRIC RESISTANCE (M01=9)

When 4 pipe heating/cooling + electric resistance is chosen, parameter M02 is automatically checked (this parameter determines the stage with which the electric resistance is combined).

If M02=0 (electric resistance disabled), it is automatically forced to 2 (electric resistance assigned to second stage). This value can be edited.

- M01=1 assigns the electric resistance to stage 1.
- M01=2 assigns the electric resistance to stage 2.
- M01=3 assigns the electric resistance to stages 1 and 2 both.

The mode is selected automatically in relation to the operating temperature (see "11. Regulation sensor(s)" page 24).

If the operating temperature is greater than $I09 + (I21 : 2)$ the icon "COOL" turns on to indicate that cooling mode is active.

If the operating temperature is lower than $I09 - (I21 : 2)$ the icon "HEAT" turns on to indicate that heating mode is active.

When the unit is turned on, if the operating temperature is in the neutral zone (I21), the mode is set to heating.

The cooling valve can be regulated with PI action if the integral time I24 is non-zero, or proportional action only if I24=0.

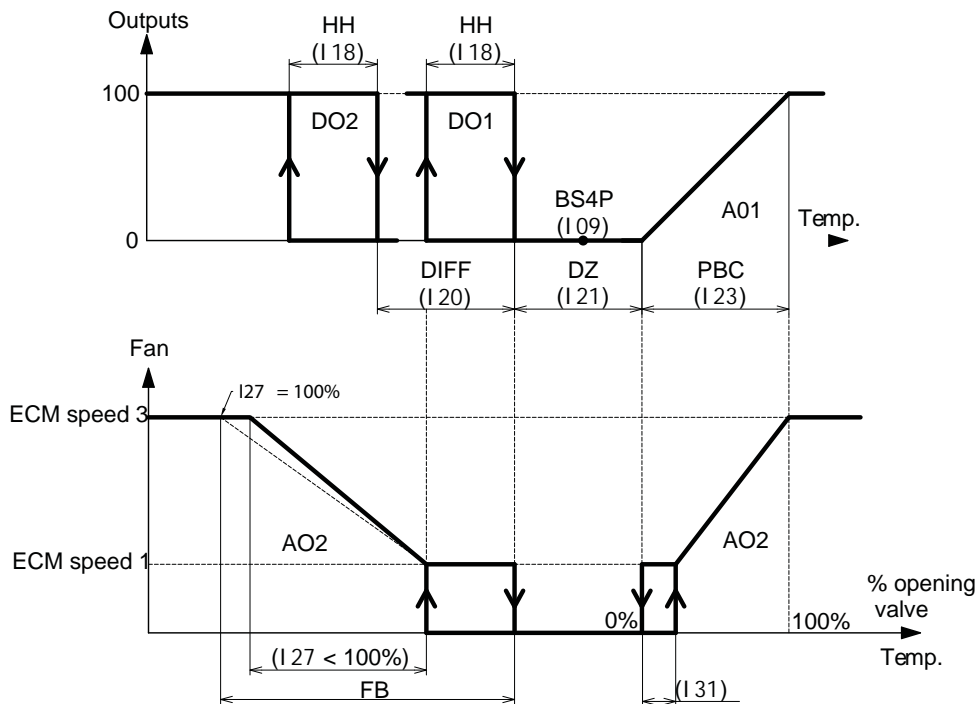

If the operating temperature drops below $I09 - (I21 : 2) - I18$, relay **DO1** is activated.

Icon turns on if M02=2 and icons and both turn on if M02=1 or 3.

The fan (output **AO2**) starts at speed 1, after the startup delay I36, if M02=2.

The fan (output **AO2**) starts immediately at speed 1, regardless of the startup delay, if M02=1 or 3.

The speed then increases as the operating temperature drops, and arrives at speed 3 when the operating temperature drops below $I09 - (I21 : 2) - I18 - [I27 \times (FB - I18)]$.

If the temperature drops below $I09 - (I21 : 2) - I20 - I18$, stage 2 (output **DO2**) is activated

If the temperature rises above $I09 - (I21 : 2) - I20$, stage 2 is deactivated. If M02=2, icon turns off.

If the operating temperature increases to $I09 - (I21 : 2) - I18$ the speed remains constant at speed 1 until the operating temperature exceeds $I09 - (I21 : 2)$.

Icon , or icons and (if M02=1 or 3) turn off and, depending on the value of I28, the fan turns off after delay I35 or stays on for air recirculation:

if I28=0 or 2, the fan stops after delay I35.

if I28=1 or 3, the fan stays on at speed 1.

if I28=4 or 6, the fan stays on at speed selected manually.

N.B.: if the minimum thermostat function is active, the thermostat itself must be closed when the valve is in regulation, otherwise the fan will not start. If, on the other hand, the electric resistance turns on, the fan starts immediately regardless of the position of the minimum thermostat.

If the operating temperature rises above $I09 + (I21 : 2)$ the cooling valve starts to open (output **AO1**). Icon turns on. The fan (output **AO2**) starts when the valve reaches the minimum aperture given by parameter I31, and after the fan start delay I36 has expired.

The speed increases linearly as the valve opens. Speed 3 is reached when the valve is fully open (see *“EC motor automatic speed control logic with 0..10 V modulating outputs” page 28*).

Icon  turns off when the valve closes again, in which case the fan stops if I 28=0 or 3. The fan maintains speed 1 if I 28=1 or 2. The fan maintains speed selected manually if I 28=4 or 5.

Wiring diagram

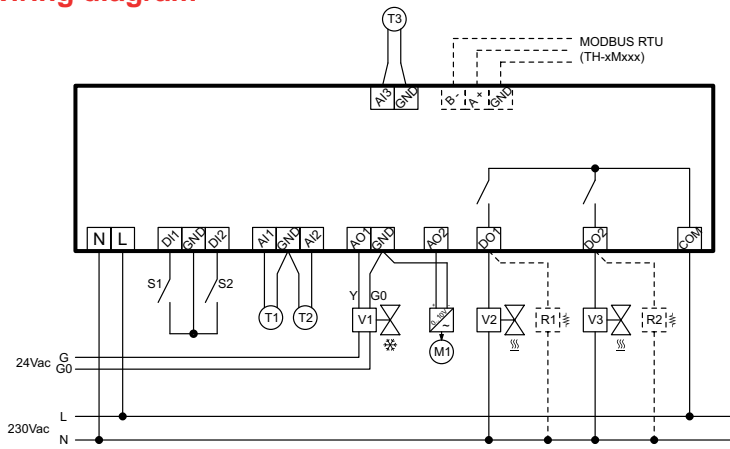

N.B.: only standard EC motors can be used for this application (M14=1).

TH-1xxSx1

• **COOLING mode (M01=10)**

The “COOL” icon is on to indicate that cooling mode is active.

The regulation logic is as follows:

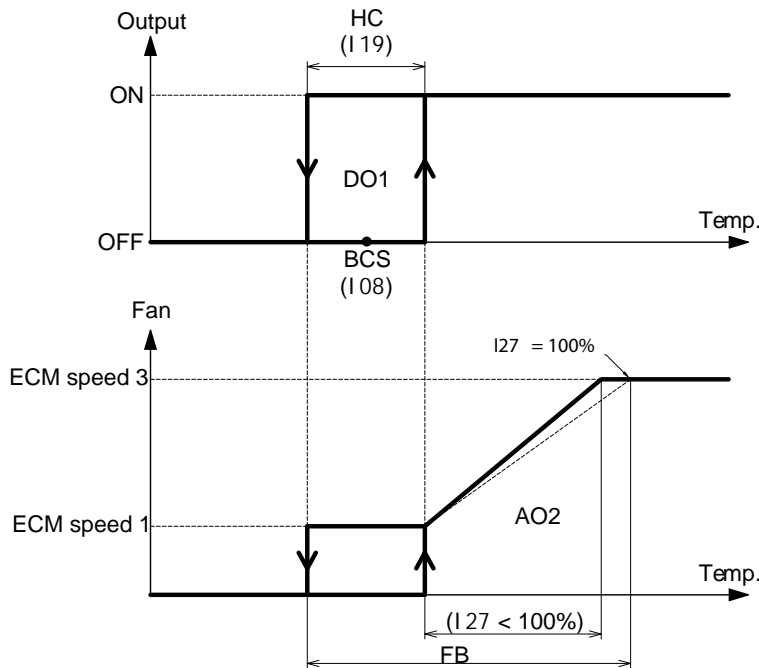

If the operating temperature rises above $I08 + (I19 : 2)$ relay **DO1** is activated and the fan starts (output **AO2**) at speed 1 after startup delay $I36$. The speed then increases as the operating temperature increases, arriving at speed 3 when the temperature exceeds $I08 + (I19 : 2) + [I27 \times (FB - I19)]$.

The icon  turns on to indicate that cooling mode is active.

If the operating temperature drops to $I08 + (I19 : 2)$ the speed remains constant at 1 until the operating temperature falls below $I08 - (I19 : 2)$.

The icon  now turns off and, depending on the value of $I28$, the fan either stops or stays on:

if $I28=0$ or 3 , the fan stops,

if $I28=1$ or 2 , the fan stays on at speed 1.

if $I28=4$ or 5 , the fan stays on at speed selected manually.

Wiring diagram

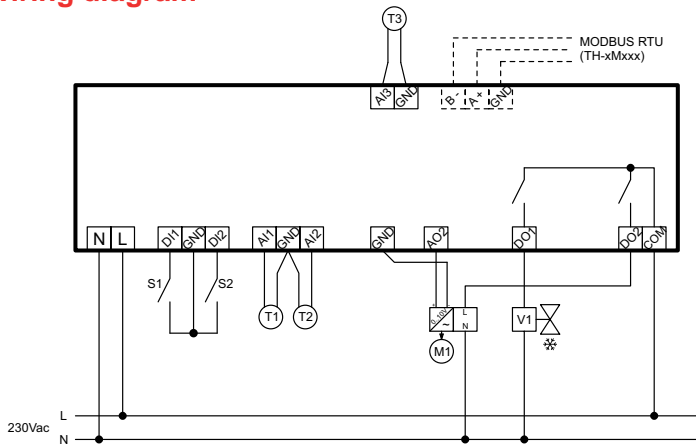

• **COOLING/COOLING mode (M01=11)**

The “COOL” icon is on to indicate that cooling mode is active.

The regulation logic is as follows:

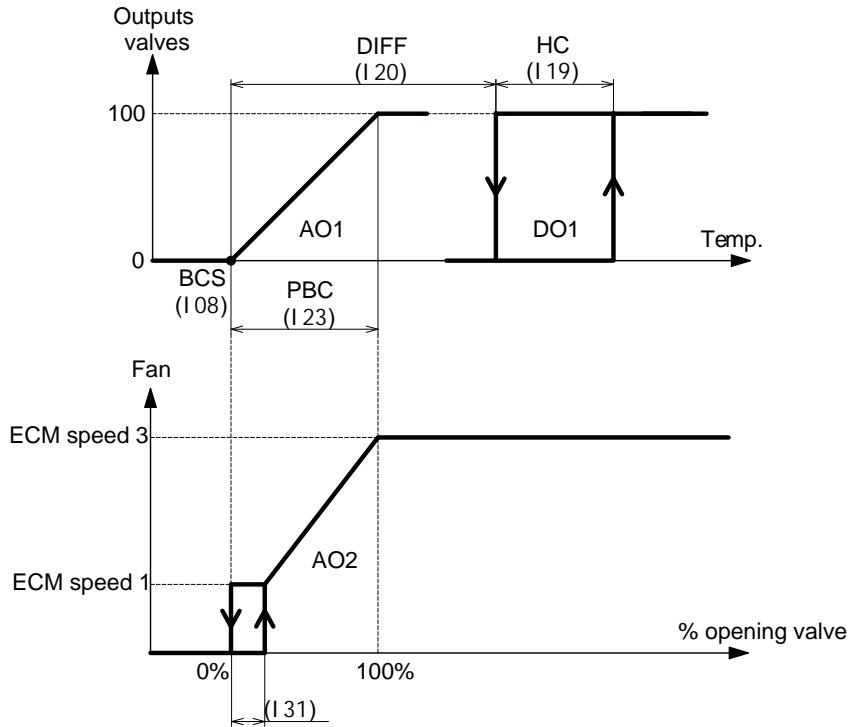

If the operating temperature rises above I 08 the valve starts opening (output **AO1**).

The icon ❄️ turns on to indicate that cooling mode is active.

The valve can be regulated with PI action if the integral time I 24 is non-zero, or with proportional action only if I 24=0.

The fan (output **AO2**) starts when the valve reaches the minimum aperture given by parameter I 31, and after the fan start delay I 36 has expired.

The speed increases linearly as the valve opens. Speed 3 is reached when the valve is fully open (see *“EC motor automatic speed control logic with 0..10 V modulating outputs” page 28*).

Digital output **DO1** activates if the temperature exceeds I 08 + I 20 + I 19.

Digital output **DO1** deactivates if the temperature drops below I 08 + I 20.

Icon ❄️ turns off when the valve closes again, in which case the fan stops if I 28=0 or 3. The fan maintains speed 1 if I 28=1 or 2. The fan maintains speed selected manually if I 28=4 or 5.

Wiring diagram

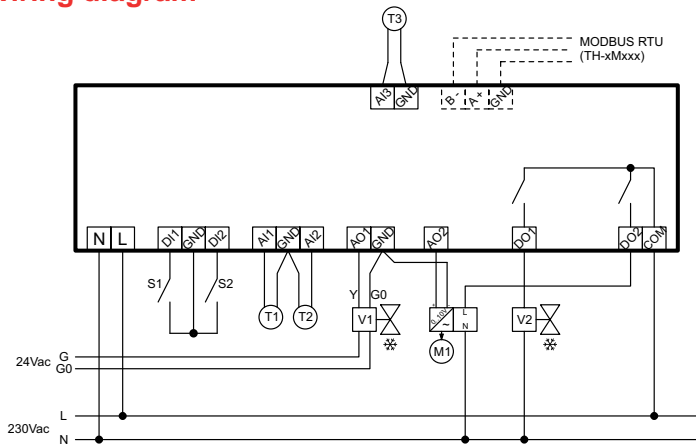

31. Regulation with EC motor (Model TH-2xxSx1)

All the graphics below refer to automatic speed control.

• HEATING mode (M01=0)

The "HEAT" icon is on to indicate that heating mode is active.

The regulation logic is as follows:

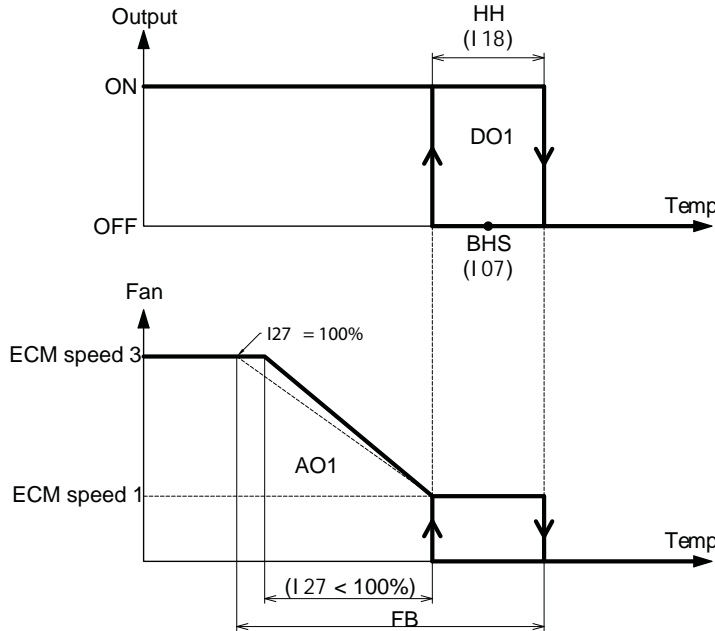

- Operation with M02=0 or 2 (digital output **DO1** does not control an electric resistance).

If the operating temperature drops below $I07 - (I18 : 2)$ relay **DO1** is activated and the fan starts (output **AO1**) at speed 1 after startup delay $I36$. The speed then increases as the operating temperature drops until it reaches speed 3 when the operating temperature falls below $I07 - (I18 : 2) - [I27 \times (FB - I18)]$.

The icon turns on to indicate that heating is active.

If the operating temperature increases to $I07 - (I18 : 2)$ the speed remains constant at speed 1 until the operating temperature rises above $I07 + (I18 : 2)$.

At this point, icon turns off and, depending on the value of parameter $I28$, the fan either stops or continues running:

- if $I28=0$ or 2 , the fan stops,
- if $I28=1$ or 3 , the fan stays on at speed 1.
- if $I28=4$ or 6 , the fan stays on at speed selected manually.

- Operation with M02=1 or 3 (digital output **DO1** controls an electric resistance).

If the operating temperature drops below $I07 - (I18 : 2)$ relay **DO1** is activated and the fan starts immediately at speed 1, regardless of the startup delay $I36$. The speed then increases as the operating temperature drops until it reaches speed 3 when the operating temperature falls below $I07 - (I18 : 2) - [I27 \times (FB - I18)]$.

Icons and turn on to indicate heating with electric resistance.

If the operating temperature increases to $I07 - (I18 : 2)$ the speed remains constant at speed 1 until the operating temperature rises above $I07 + (I18 : 2)$.

Icons and are now off and, depending on the value of $I28$, the fan stops after delay $I35$ or remains active for air recirculation:

- if $I28=0$ or 2 , the fan stops after delay $I35$.
- if $I28=1$ or 3 , the fan stays on at speed 1.
- if $I28=4$ or 6 , the fan stays on at speed selected manually.

N.B.: if the minimum thermostat function is active, the thermostat itself must be closed when the valve is in regulation, otherwise the fan will not start. If, on the other hand, the electric resistance turns on, the fan starts immediately regardless of the position of the minimum thermostat.

Wiring diagram

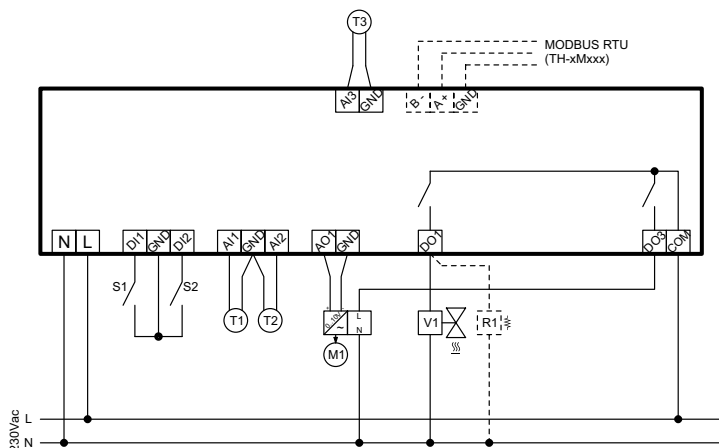

TH-2xxSx1 with EC motor

• **HEATING/HEATING mode (M01=1)**

The "HEAT" icon is on to indicate that heating mode is active.

The regulation logic is as follows:

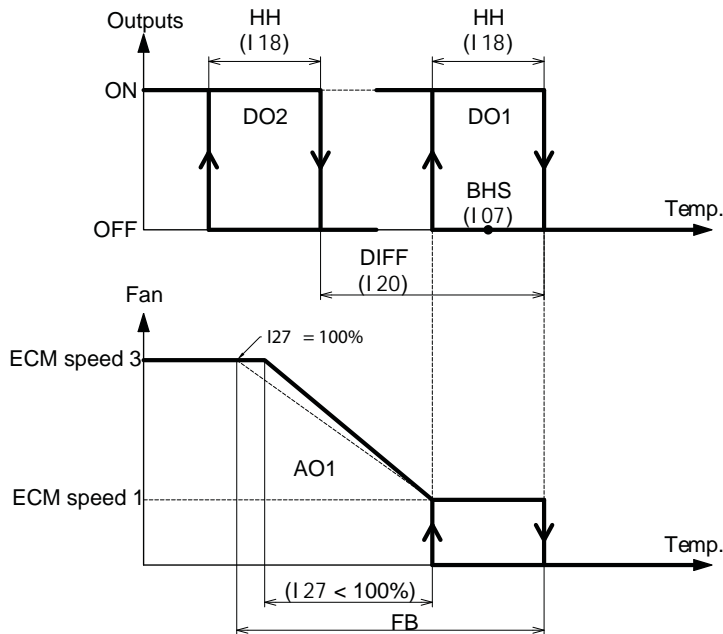

If the operating temperature drops below I 07 - (I 18 : 2) relay **DO1** is activated.

Icon turns on if M02=2 and icons and both turn on if M02=1 or 3.

The fan (output **AO1**) is activated at speed 1 after startup delay I 36 if M02=2.

The fan (output **AO1**) starts immediately at speed 1, regardless of the startup delay I36, if M02=1 or 3.

The speed then increases as the operating temperature falls, arriving at speed 3 when the operating temperature drops below I 07 - (I 18 : 2) - [I 27 x (FB - I 18)].

If the operating temperature drops below I 07 - (I 18 : 2) - I 20, stage 2 is activated (output **DO2**)

If the temperature rises above I 07 + (I 18 : 2) - I 20, stage 2 is deactivated. if M02=2, icon turns off.

If the operating temperature increases to I 07 - (I 18 : 2) the speed remains constant at speed 1, until the operating temperature exceeds I 07 + (I 18 : 2)

Icon , or icons and (if M02=1 or 3) turn off and, depending on the value of I 28, the fan turns off after delay I 35 or stays on for air recirculation:

if I 28=0 or 2, the fan stops after delay I 35.

if I 28=1 or 3, the fan stays on at speed 1.

if I 28=4 or 6, the fan stays on at speed selected manually.

N.B.: if the minimum thermostat function is active, the thermostat itself must be closed when the valve is in regulation, otherwise the fan will not start. If, on the other hand, the electric resistance turns on, the fan starts immediately regardless of the position of the minimum thermostat.

Wiring diagram

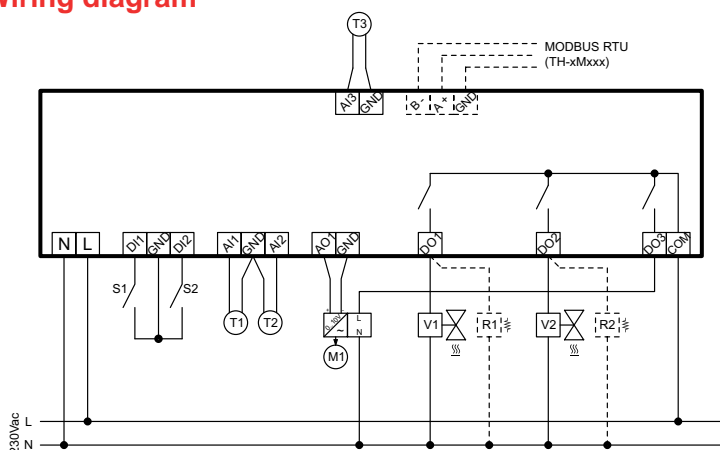

TH-2xxSx1 with EC motor

• **2 PIPE HEATING/COOLING mode with AUTOMATIC SEASON CHANGEOVER (M01=2):**

The mode is selected automatically by the water sensor. Use a remote sensor for this function. Set parameters M07=1 or M09=1 or M11=1 and set the water sensor's thresholds to define the function with parameters I 15 and I 16. Select the mode of automatic season changeover between the following graphs by parameter I 54.

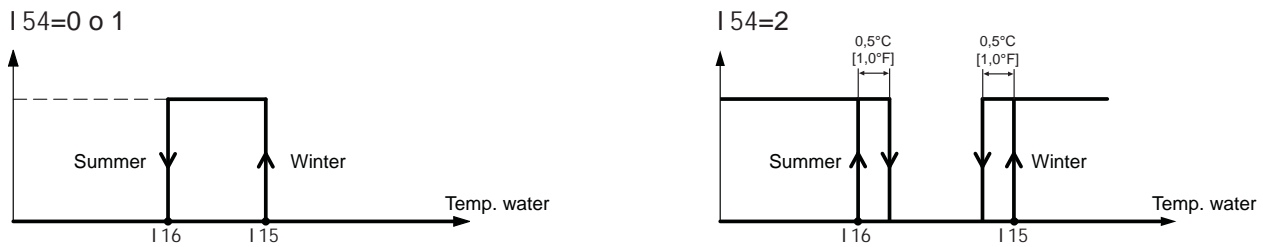

When the unit is turned on, if the water sensor temperature is between I 16 and I 15, see paragraph [“12. Automatic season changeover with water sensor \(M01=2 or 5\)” page 24](#) for working season definition.

N.B.: if no remote sensor is configured as water sensor for season changeover function, the operating mode is not defined and the regulation does not start.

• **2 PIPE HEATING/COOLING mode with SEASON CHANGEOVER by CONTACT (M01=3):**

The season is selected by the position of remote contact **DI1** or **DI2** configured with the “remote contact season changeover” function. Configure one of the digital contacts as shown in the following table.

M03 (or M05)=0 Remote season changeover contact	M04 (or M06)=	0	1
	Summer		
	Winter		

If the digital contacts are used for other functions, you can use a remote sensor input as “remote contact season changeover” by configuring one of the remote sensors as shown in the table.

M07 (M09 or M11)=0 Remote season changeover contact	M08 (M10 or M12)=	0	1
	Summer		
	Winter		

N.B.: if no digital contact and no remote sensor are configured as “remote contact season changeover”, the operating mode is heating.

• **2 PIPE HEATING/COOLING with SEASON CHANGEOVER by PARAMETER (M01=4):**

The season is selected manually (see *“MODE button functionality” page 9*).

Once you have made the selection, either **“HEAT”** or **“COOL”** is displayed, depending on the mode.

Heating regulation is controlled as follows for 2 pipe heating/cooling mode (M01=2, 3, 4):

The **“HEAT”** icon is on to indicate that heating mode is active.

The regulation logic is as follows:

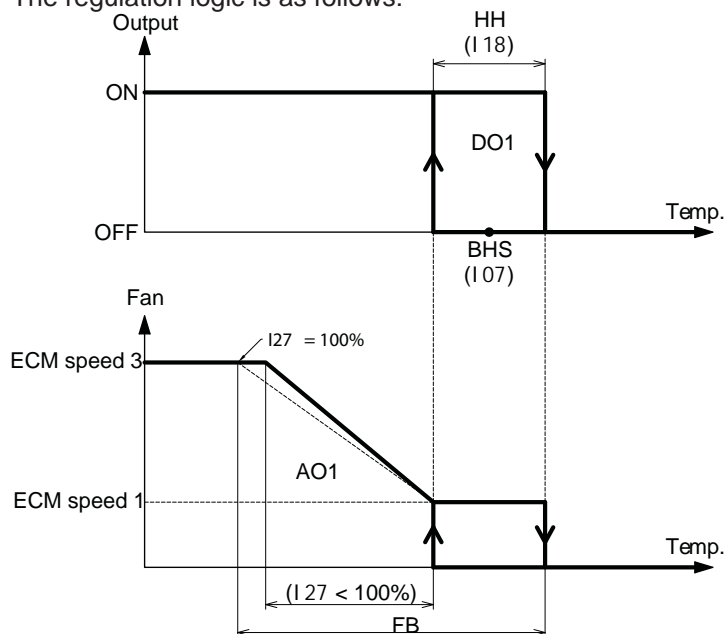

- Operation with M02=0 or 2 (digital output **DO1** does not control an electric resistance).

If the operating temperature drops below I 07 - (I 18 : 2) relay **DO1** is activated and the fan starts (output **AO1**) at speed 1 after startup delay I 36. The speed increases as the operating temperature drops, reaching speed 3 when the operating temperature falls below I 07 - (I 18 : 2) - [I 27 x (FB - I 18)].

The icon turns on to indicate that heating is active.

If the operating temperature increases to I 07 - (I 18 : 2) the speed remains constant at speed 1 until the operating temperature rises above I 07 + (I 18 : 2).

At this point, icon turns off and, depending on the value of parameter I 28, the fan either stops or continues running:

if I 28=0 or 2, the fan stops,

if I 28=1 or 3, the fan stays on at speed 1.

if I 28=4 or 6, the fan stays on at speed selected manually.

- Operation with M02=1 or 3 (digital output **DO1** controls an electric resistance).

If the operating temperature drops below I 07 - (I 18 : 2) relay **DO1** is activated and the fan starts immediately at speed 1, regardless of the startup delay I 36. The speed then increases as the operating temperature drops until it reaches speed 3 when the operating temperature falls below I 07 - (I 18 : 2) - [I 27 x (FB - I 18)].

Icons and turn on to indicate heating with electric resistance.

If the operating temperature increases to I 07 - (I 18 : 2) the speed remains constant at speed 1 until the operating temperature rises above I 07 + (I 18 : 2).

At this point, icons and turn off and, depending on the value of I 28, the fan either stops after a delay I 35 or stays on for air recirculation:

if I 28=0 or 2, the fan stops after delay I 35.

if I 28=1 or 3, the fan stays on at speed 1.

if I 28=4 or 6, the fan stays on at speed selected manually.

N.B.: if the minimum thermostat function is active, the thermostat itself must be closed when the valve is in regulation, otherwise the fan will not start. If, on the other hand, the electric resistance turns on, the fan starts immediately regardless of the position of the minimum thermostat.

Cooling regulation is controlled as follows for 2 pipe heating/cooling mode (M01=2, 3, 4):

The “COOL” icon is on to indicate that cooling mode is active.

The regulation logic is as follows:

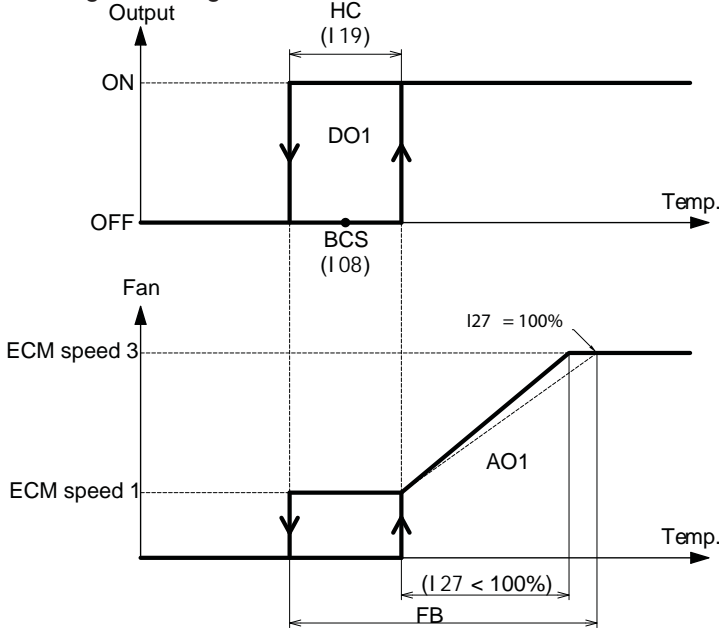

If the operating temperature rises above $I08 + (I19 : 2)$ relay **DO1** is activated and the fan starts (output **AO1**) at speed 1 after startup delay I36. The speed then increases as the operating temperature increases, arriving at speed 3 when the operating temperature exceeds $I08 + (I19 : 2) + [I27 \times (FB - I19)]$.

The icon  turns on to indicate that cooling mode is active.

If the operating temperature drops to $I08 + (I19 : 2)$ the speed remains constant at speed 1, until the operating temperature drops below $I08 - (I19 : 2)$.

The icon  now turns off and, depending on the value of I28, the fan either stops or stays on:

if $I28=0$ or 3, the fan stops,

if $I28=1$ or 2, the fan stays on at speed 1.

if $I28=4$ or 5, the fan stays on at speed selected manually.

Wiring diagram

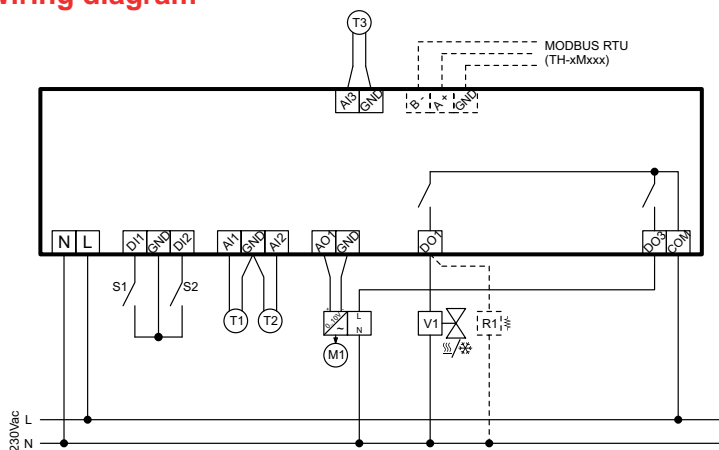

TH-2xxSx1 with EC motor

• **2 PIPE HEATING/COOLING + ELECTRIC RESISTANCE mode with AUTOMATIC SEASON CHANGEOVER (M01=5):**

The mode is selected automatically by the water sensor. Use a remote sensor for this function. Set parameters M07=1 or M09=1 or M11=1 and set the water sensor's thresholds to define the function with parameters I 15 and I 16. Select the mode of automatic season changeover between the following graphs by parameter I 54.

I 54=0 o 1

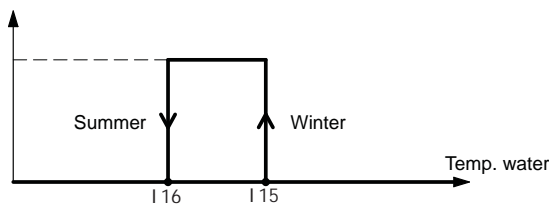

I 54=2

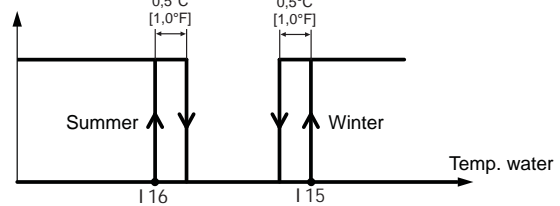

When the unit is turned on, if the water sensor temperature is between I 16 and I 15, see paragraph [“12. Automatic season changeover with water sensor \(M01=2 or 5\)” page 24](#) for working season definition.

N.B.: if no remote sensor is configured as water sensor for season changeover function, the operating mode is not defined and the regulation does not start.

• **2 PIPE HEATING/COOLING + ELECTRIC RESISTANCE mode with SEASON CHANGE-OVER by CONTACT (M01=6):**

The season is selected by the position of remote contact **DI1** or **DI2** configured with the “remote contact season changeover” function. Configure one of the digital contacts as shown in the following table.

M03 (or M05)=0 Remote season changeover contact	M04 (or M06)=	0	1
	Summer		
	Winter		

If the digital contacts are used for other functions, you can use a remote sensor input as “remote contact season changeover” by configuring one of the remote sensors as shown in the table.

M07 (M09 or M11)=0 Remote season changeover contact	M08 (M10 or M12)=	0	1
	Summer		
	Winter		

N.B.: if no digital contact and no remote sensor are configured as “remote contact season changeover”, the operating mode is heating.

• **2 PIPE HEATING/COOLING + ELECTRIC RESISTANCE mode with SEASON CHANGEOVER by PARAMETER (M01=7):**

The season is selected manually (see “*MODE button functionality*” page 9).

Once you have made the selection, either “**HEAT**” or “**COOL**” is displayed, depending on the mode.

Heating regulation is controlled as follows for 2 pipe heating/cooling mode (M01=5, 6, 7):

The “**HEAT**” icon is on to indicate that heating mode is active.

The regulation logic is as follows:

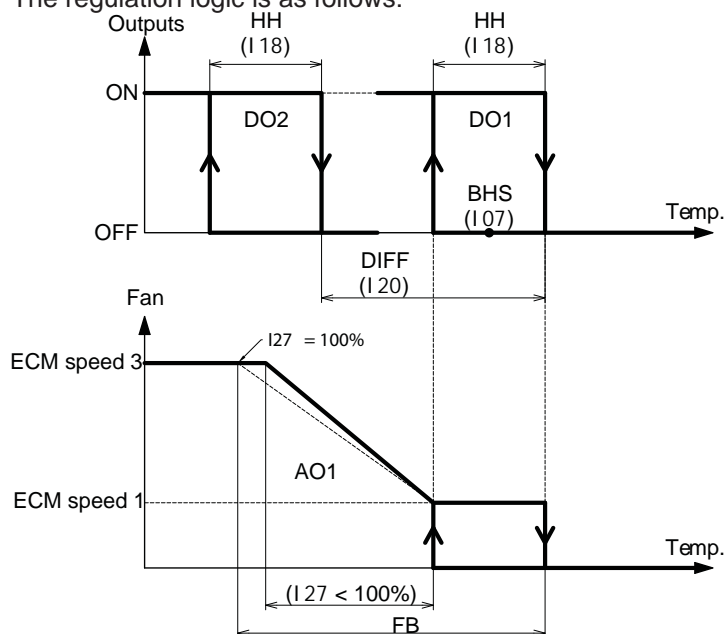

If the operating temperature drops below I 07 - (I 18 : 2) relay **DO1** is activated.

Icon turns on if M02=2 and icons and both turn on if M02=1 or 3.

The fan (output **AO1**) starts at speed 1, after the startup delay I 36, if M02=2.

The fan (output **AO1**) starts immediately at speed 1, regardless of the startup delay, if M02=1 or 3.

The speed then increases as the operating temperature falls, arriving at speed 3 when the temperature drops below I 07 - (I 18 : 2) - [I 27 x (FB - I 18)].

If the operating temperature drops below I 07 - (I 18 : 2) - I 20, stage 2 is activated (output **DO2**)

If the temperature rises above I 07 + (I 18 : 2) - I 20, stage 2 is deactivated. if M02=2, icon turns off.

If the operating temperature increases to I 07 - (I 18 : 2) the speed remains constant at speed 1, until the operating temperature exceeds I 07 + (I 18 : 2).

Icon , or icons and (if M02=1 or 3) turn off and, depending on the value of I 28, the fan turns off after delay I 35 or stays on for air recirculation:

if I 28=0 or 2, the fan stops after delay I 35.

if I 28=1 or 3, the fan stays on at speed 1.

if I 28=4 or 6, the fan stays on at speed selected manually.

N.B.: if the minimum thermostat function is active, the thermostat itself must be closed when the valve is in regulation, otherwise the fan will not start. If, on the other hand, the electric resistance turns on, the fan starts immediately regardless of the position of the minimum thermostat.

Cooling regulation is controlled as follows for 2 pipe heating/cooling mode (M01=5, 6, 7):

- Operation without half season function (M15=0):

The "COOL" icon is on to indicate that cooling mode is active.

The regulation logic is as follows:

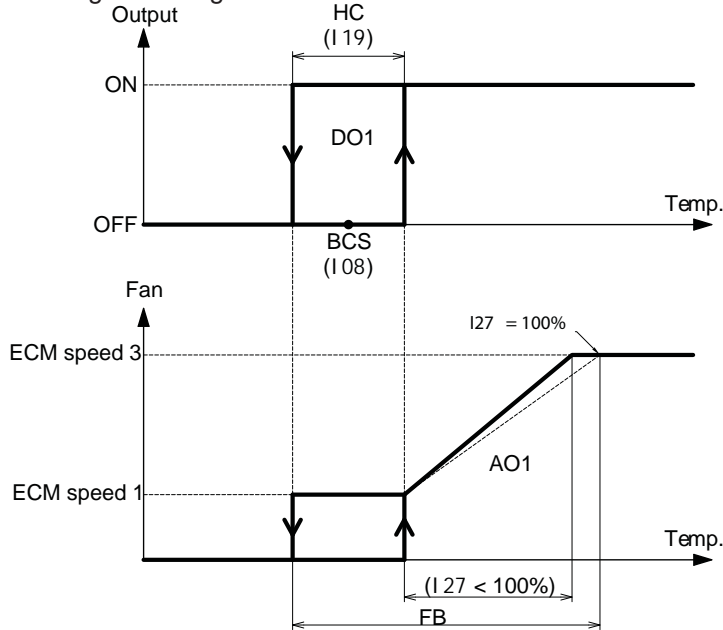

If the operating temperature rises above $I08 + (I19 : 2)$ relay **DO1** is activated and the fan starts (output **AO1**) at speed 1 after startup delay $I36$. The speed then increases as the operating temperature increases, arriving at speed 3 when the operating temperature exceeds $I08 + (I19 : 2) + [I27 \times (FB - I19)]$.

The icon  turns on to indicate that cooling mode is active.

If the operating temperature drops to $I08 + (I19 : 2)$ the speed remains constant at speed 1, until the operating temperature drops below $I08 - (I19 : 2)$.

The icon  now turns off and, depending on the value of $I28$, the fan either stops or stays on:

if $I28=0$ or 3 , the fan stops,

if $I28=1$ or 2 , the fan stays on at speed 1.

if $I28=4$ or 5 , the fan stays on at speed selected manually.

- Operation with half season function (M15=1):

The "COOL" icon is on to indicate that cooling mode is active.

The mode is selected automatically in relation to the operating temperature (see "11. Regulation sensor(s)" page 24).

If the operating temperature is greater than $I08 + (I19 : 2)$, the icon "COOL" turns on to indicate that cooling mode is active.

If the operating temperature is lower than $I08 - (I19 : 2) - I21 - I18$, the icon "HEAT" turns on to indicate that heating mode is active.

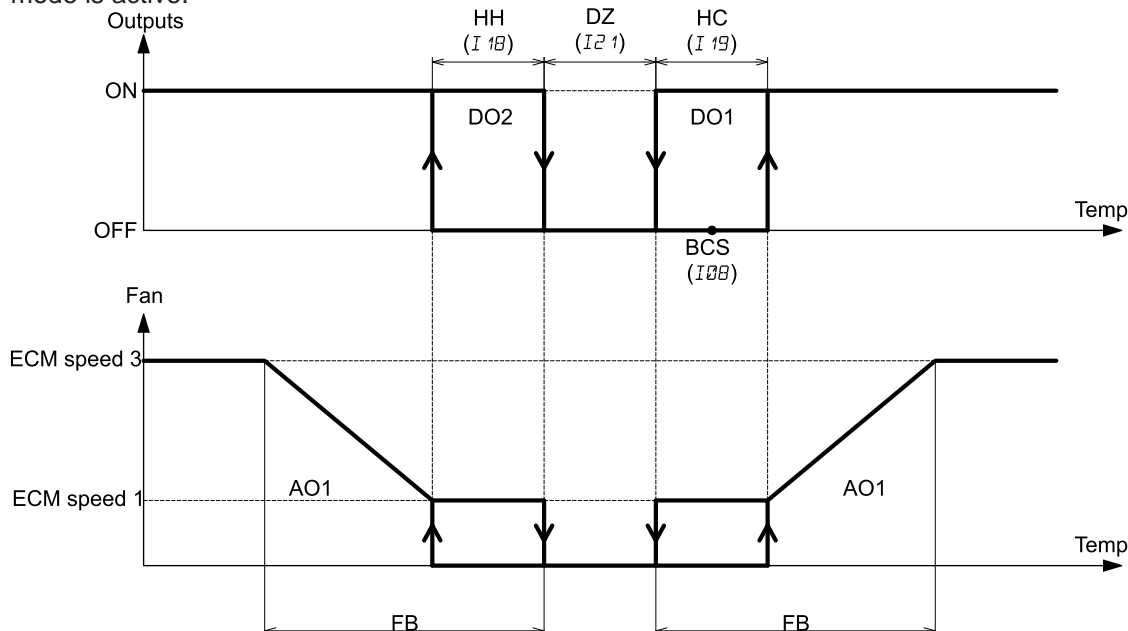

If the operating temperature drops below $I 08 - (I 19 : 2) - I 21 - I 18$, the electric resistance (DO2) starts and the fan starts at speed 1. The speed increases as the operating temperature drops, reaching speed 3 when the operating temperature falls below $I 08 - (I 19 : 2) - I 21 - I 18 - [I 27 \times (FB - I 18)]$.

Icon  turns on.

If the operating temperature increases to $I 08 - (I 19 : 2) - I 21 - I 18$ the speed remains constant at speed 1 until the operating temperature exceeds $I 08 - (I 19 : 2) - I 21$.

Icon  turns off.

if $I 28=0$ or 2, the fan stops after delay $I 35$.

if $I 28=1$ or 3, the fan stays on at speed 1.

if $I 28=4$ or 6, the fan stays on at speed selected manually.

If the operating temperature rises above $I 08 + (I 19 : 2)$, the cooling stage is activated and fan starts at speed 1, after startup delay $I 36$. The speed increases as the operating temperature increases, reaching speed 3 when the operating temperature exceeds $I 08 + (I 19 : 2) + [I 27 \times (FB - I 19)]$.

Icon  turns on.

If the operating temperature falls to $I 08 + (I 19 : 2)$ the fan stays at speed 1 until the operating temperature drops below $I 08 - (I 19 : 2)$.

Icon  turns off and cooling stage is deactivated.

if $I 28=0$ or 3, the fan stops,

if $I 28=1$ or 2, the fan stays on at speed 1.

if $I 28=4$ or 5, the fan stays on at speed selected manually.

Wiring diagram

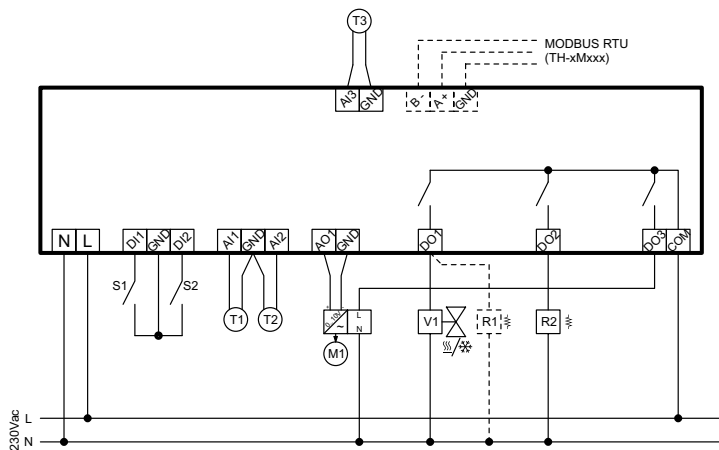

TH-2xxSx1 with EC motor

• 4 PIPE HEATING/COOLING mode (M01=8)

The mode is selected automatically in relation to the operating temperature (see "11. Regulation sensor(s)" page 24). If the operating temperature is greater than $I09 + (I21 : 2) + I19$, the icon "COOL" turns on to indicate that cooling mode is active.

If the operating temperature is lower than $I09 - (I21 : 2) - I18$, the icon "HEAT" turns on to indicate that heating mode is active.

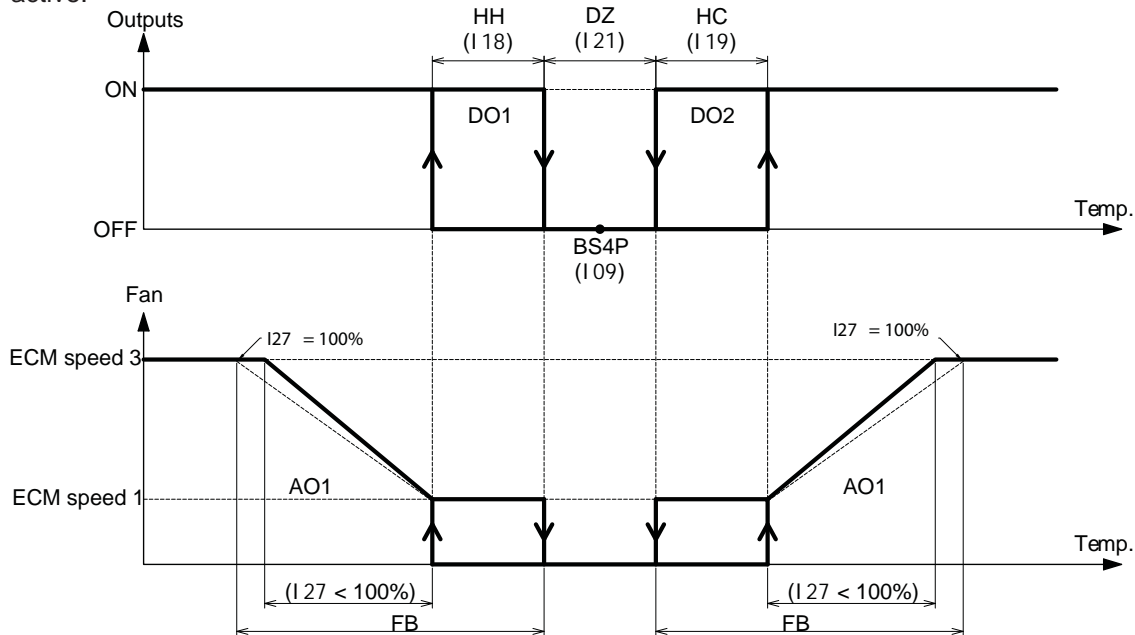

If the operating temperature drops below $I09 - (I21 : 2) - I18$, the heating stage starts and the fan starts at speed 1 after startup delay $I36$. The speed increases as the operating temperature drops, reaching speed 3 when the operating temperature falls below $I09 - (I21 : 2) - I18 - [I27 \times (FB - I18)]$.

Icon turns on. If M02=1, indicating the presence of the electric resistance, icon turns on.

If the operating temperature increases to $I09 - (I21 : 2) - I18$ the speed remains constant at speed 1 until the operating temperature exceeds $I09 - (I21 : 2)$.

Icon turns off, as does icon (if M02=1).

If $I28=0$ or 2, the fan stops after delay $I35$ (if M02=1) or the fan stops if M02=0.

If $I28=1$ or 3, the fan stays on at speed 1.

If $I28=4$ or 6, the fan stays on at speed selected manually.

If the operating temperature rises above $I09 + (I21 : 2) + I19$, the cooling stage is activated and fan starts at speed 1, after startup delay $I36$. The speed increases as the operating temperature increases, reaching speed 3 when the operating temperature exceeds $I09 + (I21 : 2) + I19 + [I27 \times (FB - I19)]$.

Icon turns on.

If the operating temperature falls to $I09 + (I21 : 2) + I19$, the fan stays at speed 1 until the operating temperature drops below $I09 + (I21 : 2)$.

Then icon turns off and cooling stage is deactivated.

If $I28=0$ or 3, the fan stops,

If $I28=1$ or 2, the fan stays on at speed 1.

If $I28=4$ or 5, the fan stays on at speed selected manually.

Wiring diagram

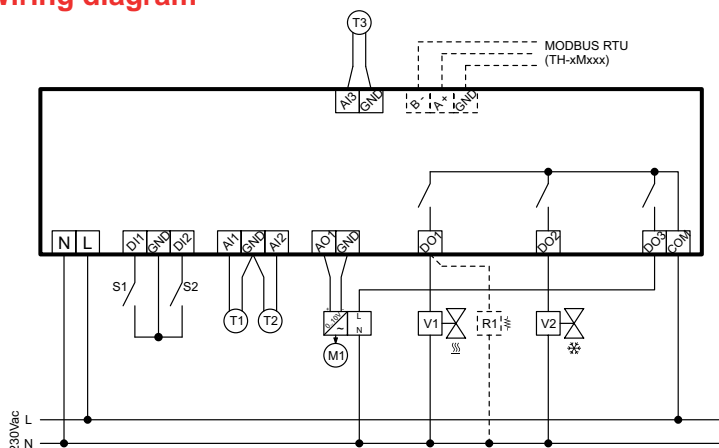

TH-2xxSx1 with EC motor

• 4 PIPE HEATING/COOLING mode + ELECTRIC RESISTANCE (M01=9)

In this configuration, you can use standard EC motors, without supplementary relays (M14=1).

When 4 pipe heating/cooling + electric resistance is chosen, parameter M02 is automatically checked (this parameter determines the stage with which the electric resistance is combined).

If M02=0 (electric resistance disabled), it is automatically forced to 2 (electric resistance assigned to second stage). This value can be edited.

- M01=1 assigns the electric resistance to stage 1.

- M01=2 assigns the electric resistance to stage 2.

- M01=3 assigns the electric resistance to stages 1 and 2 both.

The mode is selected automatically in relation to the operating temperature (see "11. Regulation sensor(s)" page 24).

If the operating temperature is greater than $I09 + (I21 : 2) + I19$, the icon "COOL" turns on to indicate that cooling mode is active. If the operating temperature is lower than $I09 - (I21 : 2) - I18$, the icon "HEAT" turns on to indicate that heating mode is active.

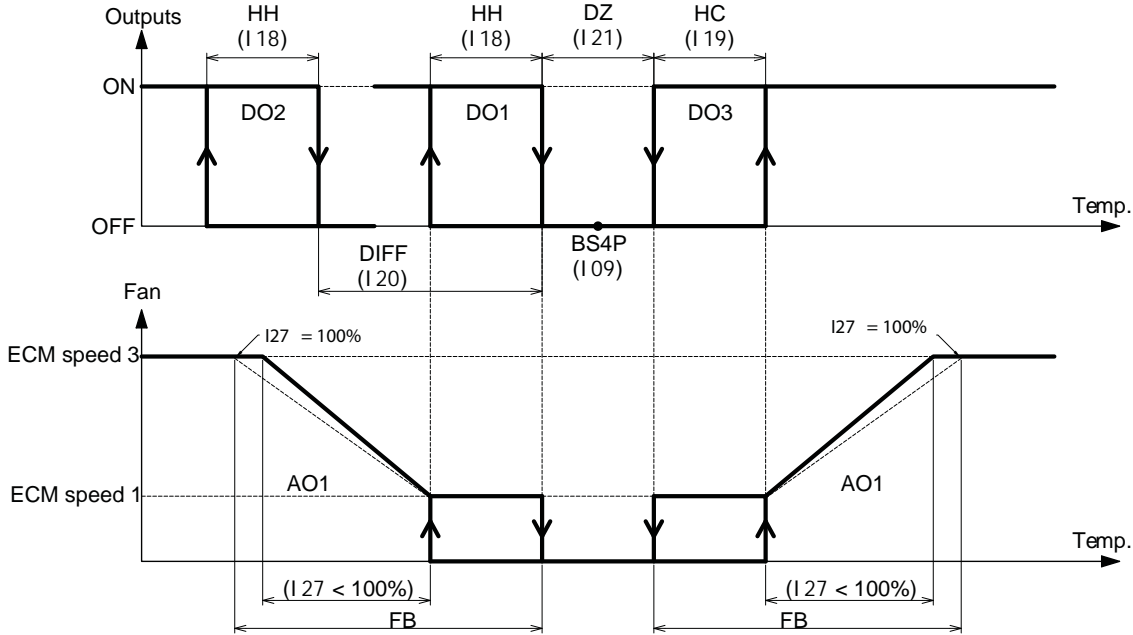

If the operating temperature drops below $I09 - (I21 : 2) - I18$, relay **DO1** is activated.

Icon turns on if M02=2 and icons and both turn on if M02=1 or 3.

The fan (output **AO1**) starts at speed 1, after the startup delay I36, if M02=2.

The fan (output **AO1**) starts immediately at speed 1, regardless of the startup delay, if M02=1 or 3.

The speed then increases as the operating temperature drops, and arrives at speed 3 when the operating temperature drops below $I09 - (I21 : 2) - I18 - [I27 \times (FB - I18)]$.

If the temperature drops below $I09 - (I21 : 2) - I20 - I18$, stage 2 (output **DO2**) is activated

If the temperature rises above $I09 - (I21 : 2) - I20$, stage 2 is deactivated. If M02=2, icon turns off.

If the operating temperature increases to $I09 - (I21 : 2) - I18$ the speed remains constant at speed 1 until the operating temperature exceeds $I09 - (I21 : 2)$.

Icon , or icons and (if M02=1 or 3) turn off and, depending on the value of I28, the fan turns off after delay I35 or stays on for air recirculation:

if I28=0 or 2, the fan stops after delay I35.

if I28=1 or 3, the fan stays on at speed 1.

if I28=4 or 6, the fan stays on at speed selected manually.

If the operating temperature rises above $I09 + (I21 : 2) + I19$, the cooling stage is activated and fan starts at speed 1, after startup delay I36. The speed increases as the operating temperature increases, reaching speed 3 when the operating temperature exceeds $I09 + (I21 : 2) + I19 + [I27 \times (FB - I19)]$.

Icon turns on.

If the operating temperature falls to $I09 + (I21 : 2) + I19$, the fan stays at speed 1 until the operating temperature drops below $I09 + (I21 : 2)$.

Then icon turns off and cooling stage is deactivated.

if I28=0 or 3, the fan stops,

if I28=1 or 2, the fan stays on at speed 1.

if I28=4 or 5, the fan stays on at speed selected manually.

N.B.: if the minimum thermostat function is active, the thermostat itself must be closed when the heating valve is in regu-

lation, otherwise the fan will not start. If, on the other hand, the electric resistance turns on, the fan starts immediately regardless of the position of the minimum thermostat.

N.B.: only standard EC motors can be used for this application (M14=1).

Wiring diagram

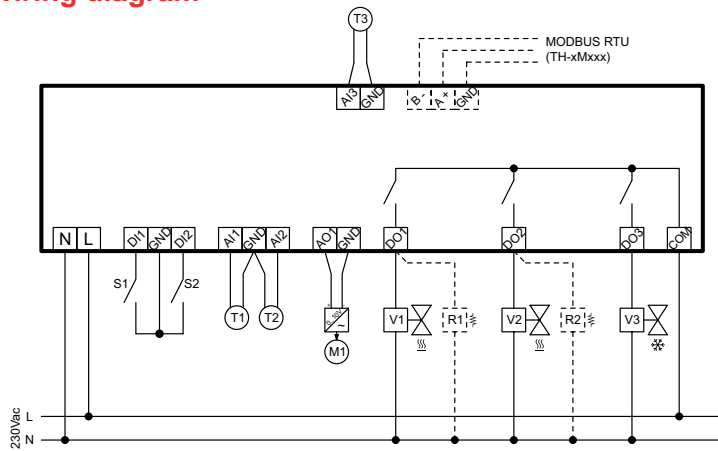

TH-2xxSx1 with EC motor

• **COOLING mode (M01=10)**

The “COOL” icon is on to indicate that cooling mode is active.

The regulation logic is as follows:

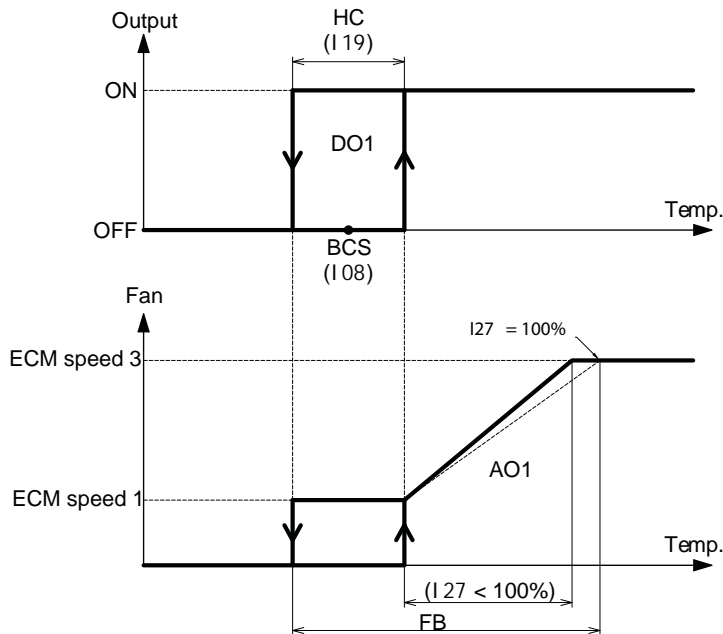

If the operating temperature rises above $I08 + (I19 : 2)$ relay **DO1** is activated and the fan starts (output **AO1**) at speed 1 after startup delay $I36$. The speed then increases as the operating temperature increases, arriving at speed 3 when the operating temperature exceeds $I08 + (I19 : 2) + [I27 \times (FB - I19)]$.

The icon  turns on to indicate that cooling mode is active.

If the operating temperature drops to $I08 + (I19 : 2)$ the speed remains constant at 1 until the operating temperature falls below $I08 - (I19 : 2)$.

The icon  now turns off and, depending on the value of $I28$, the fan either stops or stays on:

if $I28=0$ or 3 , the fan stops,

if $I28=1$ or 2 , the fan stays on at speed 1.

if $I28=4$ or 5 , the fan stays on at speed selected manually.

Wiring diagram

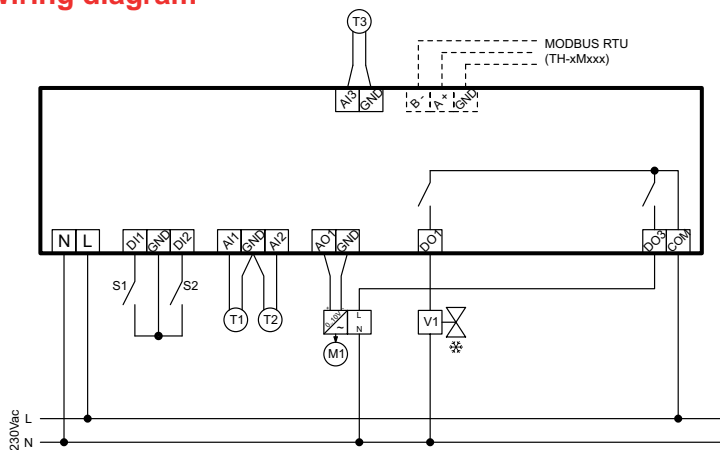

32. Control with 3 speed ON/OFF motor (Model TH-2xxSx1)

All the graphics below refer to automatic speed control.

The fan is a 3 speed on/off model, the outputs are defined as follows:

- digital output **DO1** for speed 1
- digital output **DO2** for speed 2
- digital output **DO3** for speed 3

Parameters I 29, I 30, I 31, I 32 and I 33 are not used in this type of regulation.

• **HEATING mode (M01=0)**

The "HEAT" icon is on to indicate that heating mode is active.

The regulation logic is as follows:

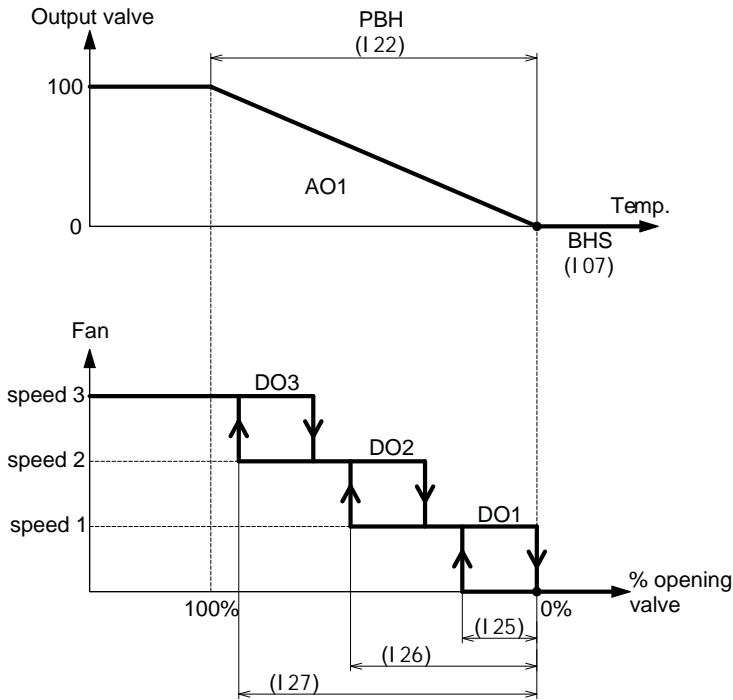

If the operating temperature drops below I 07, the valve starts opening (output **AO1**). Icon  turns on. The valve can be regulated with PI action if the integral time I 24 is non-zero, or with proportional action only if I 24=0.

The fan starts when the valve reaches the aperture given by parameter I 25, and after the fan start delay I 36 has expired.

If the temperature continues to fall, the speed switches from speed 1 to speed 2 when the valve reaches the aperture given in parameter I 26. The speed switches from speed 2 to speed 3 when the valve reaches the aperture given in parameter I 27.

Each speed is subject to a hysteresis of 20% of its activation point.

For example, for speed 3:

if I 27=100%, speed 3 is activated when the valve reaches fully open and is deactivated when the valve closes by 20% of I 27, which is 80% of fully open in this case.

Icon  turns off if the valve closes again, in which case

the fan is stopped if I 28=0 or 2. The fan stays at speed 1 if I 28=1 or 3.

If I 28=4 or 6, the fan stays on at speed selected manually.

N.B.: if the minimum thermostat function is active, the thermostat itself must be closed when the valve is in regulation, otherwise the fan will not start.

Wiring diagram

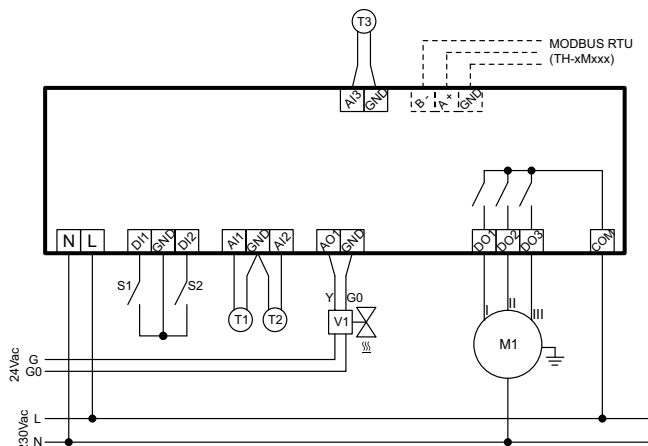

• 2 PIPE HEATING/COOLING mode with AUTOMATIC SEASON CHANGEOVER (M01=2):

The mode is selected automatically by the water sensor. Use a remote sensor for this function. Set parameters M07=1 or M09=1 or M11=1 and set the water sensor's thresholds to define the function with parameters I 15 and I 16. Select the mode of automatic season changeover between the following graphs by parameter I 54.

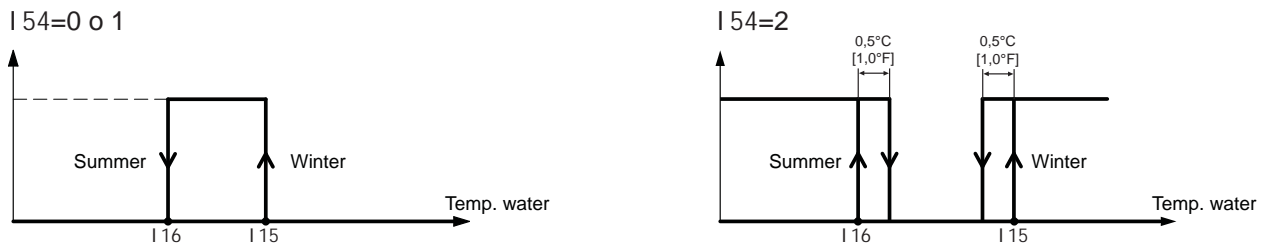

When the unit is turned on, if the water sensor temperature is between I 16 and I 15, see paragraph "12. Automatic season changeover with water sensor (M01=2 or 5)" page 24 for working season definition.

N.B.: if no remote sensor is configured as water sensor for season changeover function, the operating mode is not defined and the regulation does not start.

• 2 PIPE HEATING/COOLING mode with SEASON CHANGEOVER by CONTACT (M01=3):

The season is selected by the position of remote contact **DI1** or **DI2** configured with the "remote contact season changeover" function. Configure one of the digital contacts as shown in the following table.

M03 (or M05)=0 Remote season changeover contact	M04 (or M06)=	0	1
	Summer		
	Winter		

If the digital contacts are used for other functions, you can use a remote sensor input as "remote contact season changeover" by configuring one of the remote sensors as shown in the table.

M07 (M09 or M11)=0 Remote season changeover contact	M08 (M10 or M12)=	0	1
	Summer		
	Winter		

N.B.: if no digital contact and no remote sensor are configured as "remote contact season changeover", the operating mode is heating.

• 2 PIPE HEATING/COOLING with SEASON CHANGEOVER by PARAMETER (M01=4):

The season is selected manually (see "MODE button functionality" page 9).



Once you have made the selection, either **"HEAT"** or **"COOL"** is displayed, depending on the mode.

Heating regulation is controlled as follows for 2 pipe heating/cooling mode (M01=2, 3, 4):

The **"HEAT"** icon is on to indicate that heating mode is active.

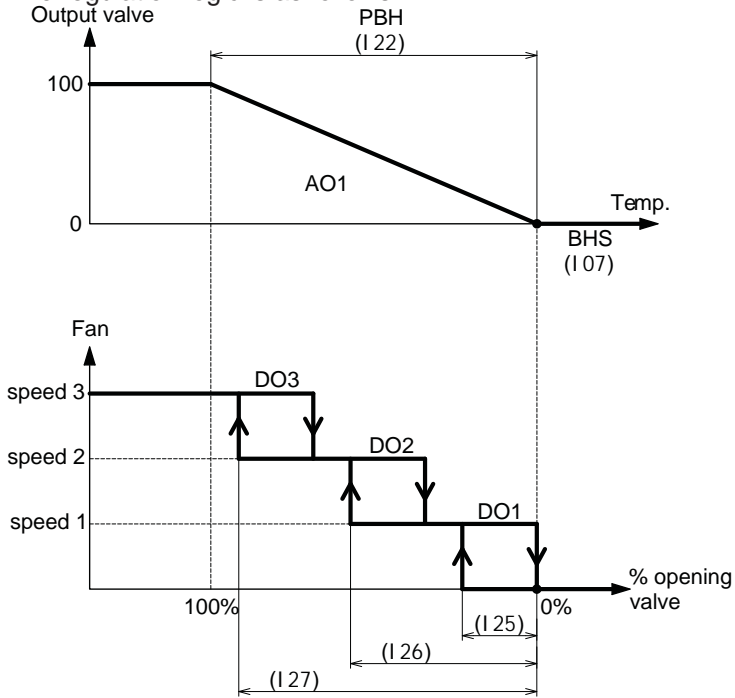
The regulation logic is as follows:



If the operating temperature drops below I 07, the valve starts opening (output **AO1**). Icon  turns on. The valve can be regulated with PI action if the integral time I 24 is non-zero or with only proportional action if I 24=0. The fan starts when the valve reaches the aperture defined in I 25 and after startup delay I 36. If the temperature continues falling, the speed switches from speed 1 to speed 2 when the valve reaches the aperture given in I 26. The speed switches from speed 2 to speed 3 when the valve reaches the aperture given in I 27. Each speed is subject to a hysteresis of 20% of its activation point. For example, for speed 3: if I 27=100%, speed 3 is activated when the valve reaches fully open and is deactivated when the valve closes by 20% of I 27, which is 80% of fully open in this case. Icon  turns off if the valve closes again, in which case the fan is stopped if I 28=0 or 2. The fan maintains speed 1 if I 28=1 or 3. The fan maintains speed selected manually if I 28=4 or 6. N.B.: if the minimum thermostat function is active, the thermostat itself must be closed when the valve is in regulation, otherwise the fan will not start.

Cooling regulation is controlled as follows for 2 pipe heating/cooling mode (M01=2, 3, 4):

The “**COOL**” icon is on to indicate that cooling mode is active.

The regulation logic is as follows:

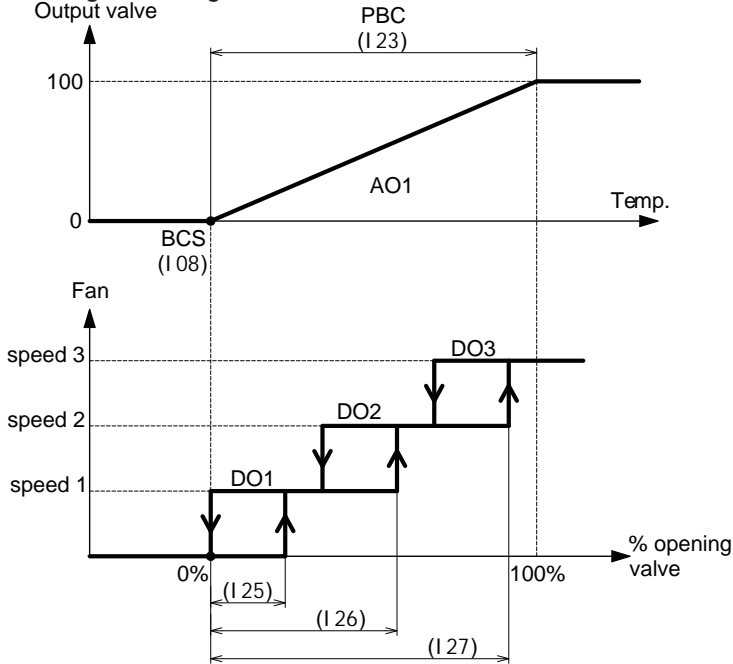

If the operating temperature rises above I08 the valve starts opening (output **AO1**). Icon ❄ turns on. The valve can be regulated with PI action if the integral time I24 is non-zero or with only proportional action if I24=0. The fan starts when the valve reaches the aperture defined in I25 and after startup delay I36. If the temperature continues increasing, the speed switches from speed 1 to speed 2 when the valve reaches the aperture given in I26. The speed switches from speed 2 to speed 3 when the valve reaches the aperture given in I27. Each speed is subject to a hysteresis of 20% of its activation point. For example, for speed 3: if I27=100%, speed 3 is activated when the valve reaches fully open and is deactivated when the valve closes by 20% of I27, which is 80% of fully open in this case.

Icon ❄ turns off when the valve closes again, in which case the fan stops if I28=0 or 3. The fan maintains speed 1 if I28=1 or 2. The fan maintains speed selected manually if I28=4 or 5.

Wiring diagram

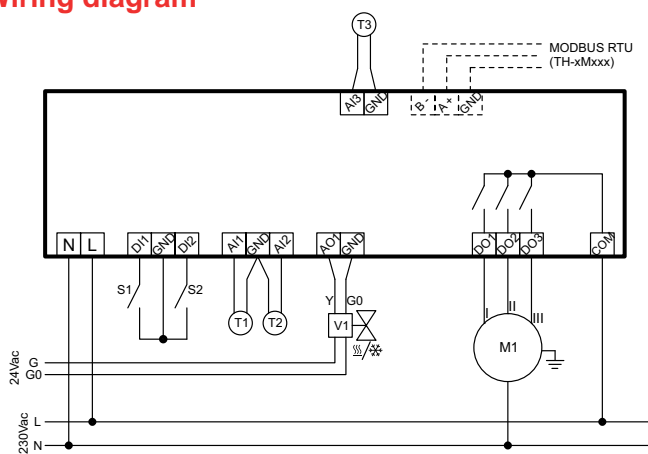

TH-2xxSx1

• **COOLING mode (M01=10)**

The “COOL” icon is on to indicate that cooling mode is active.

The regulation logic is as follows:

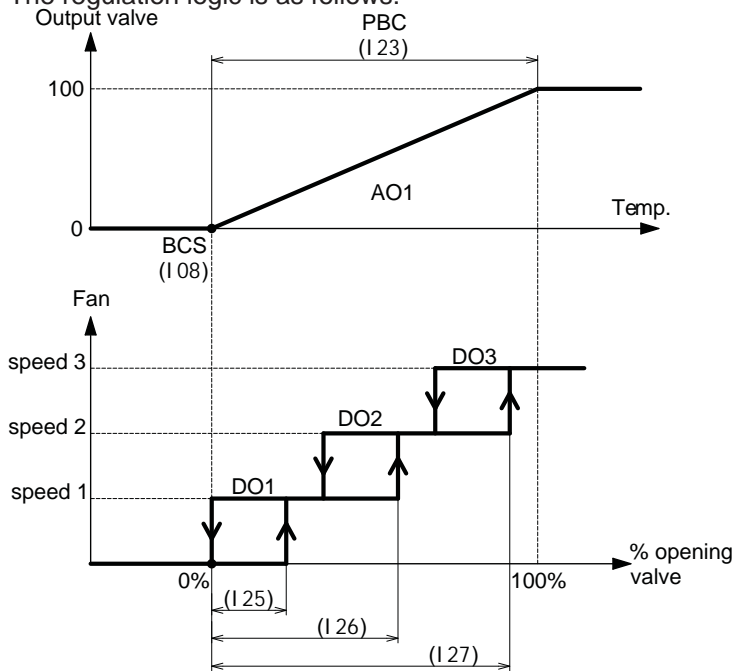

If the operating temperature rises above I08 the valve starts opening (output **AO1**). Icon ❄️ turns on.

The valve can be regulated with PI action if the integral time I24 is non-zero or with only proportional action if I24=0.

The fan starts when the valve reaches the aperture defined in I25 and after startup delay I36.

If the temperature continues increasing, the speed switches from speed 1 to speed 2 when the valve reaches the aperture given in I26. The speed switches from speed 2 to speed 3 when the valve reaches the aperture given in I27.

Each speed is subject to a hysteresis of 20% of its activation point.

For example, for speed 3:

if I27=100%, speed 3 is activated when the valve reaches fully open and is deactivated when the valve closes by 20% of I27, which is 80% of fully open in this case.

Icon ❄️ turns off if the valve closes again, in which case the fan is stopped if I28=0 or 3. The fan maintains speed 1 if I28=1 or 2. The fan maintains speed selected manually if I28=4 or 5.

Wiring diagram

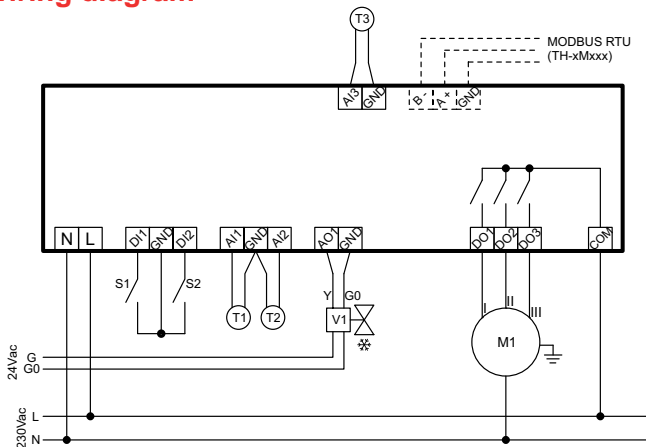

33. Regulation (Model TH-3xxSx1)

All the graphics below refer to automatic speed control.

The fan is a 3 speed on/off model, the outputs are defined as follows:

- digital output **DO1** for speed 1
- digital output **DO2** for speed 2
- digital output **DO3** for speed 3

Parameters I 29, I 30, I 31, I 32 and I 33 are not used in this type of regulation.

• HEATING mode (M01=0)

The "HEAT" icon is on to indicate that heating mode is active.

The regulation logic is as follows:

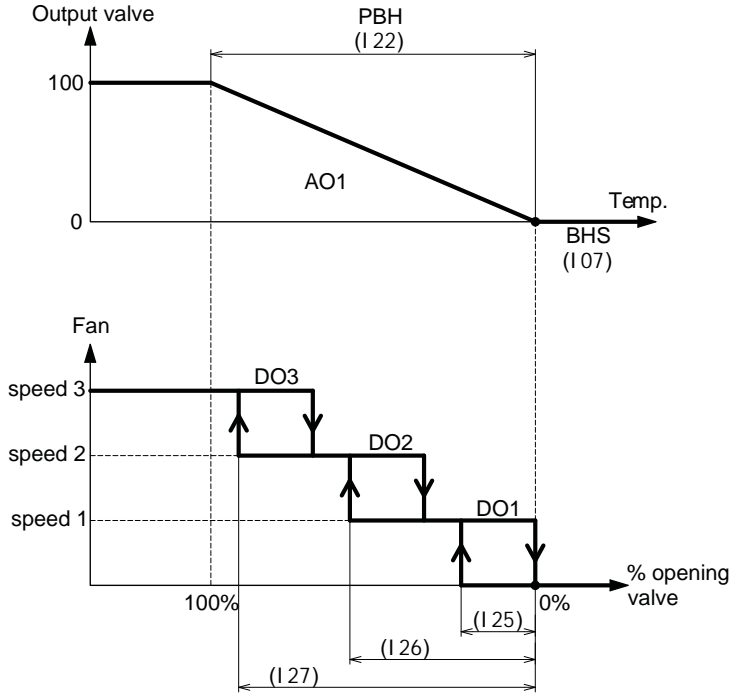

If the operating temperature drops below I 07, the valve starts opening (output **AO1**). Icon turns on. The valve can be regulated with PI action if the integral time I 24 is non-zero or with only proportional action if I 24=0.

The fan starts when the valve reaches the aperture defined in I 25 and after startup delay I 36.

If the temperature continues falling, the speed switches from speed 1 to speed 2 when the valve reaches the aperture given in I 26. The speed switches from speed 2 to speed 3 when the valve reaches the aperture given in I 27. Each speed is subject to a hysteresis of 20% of its activation point.

For example, for speed 3:

if I 27=100%, speed 3 is activated when the valve reaches fully open and is deactivated when the valve closes by 20% of I 27, which is 80% of fully open in this case.

Icon turns off when the valve closes again, in which case the fan stops if I 28=0 or 2. The fan maintains speed 1 if I 28=1 or 3.

The fan maintains speed selected manually if I 28=4 or 6.

N.B.: if the minimum thermostat function is active, the thermostat itself must be closed when the valve is in regulation, otherwise the fan will not start.

Wiring diagram

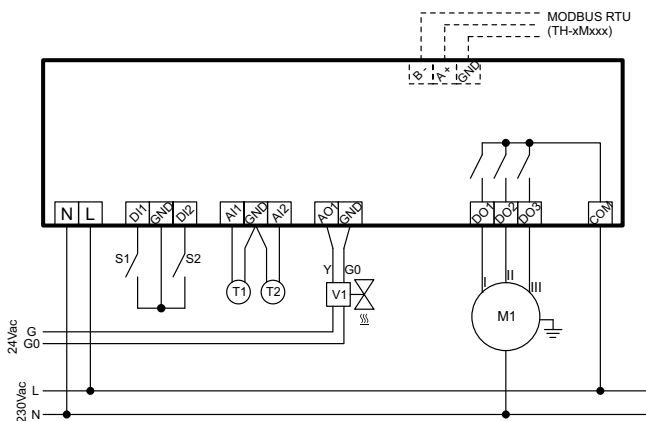

TH-3xxSx1

• HEATING/HEATING mode (M01=1)

The "HEAT" icon is on to indicate that heating mode is active.

The regulation logic is as follows:

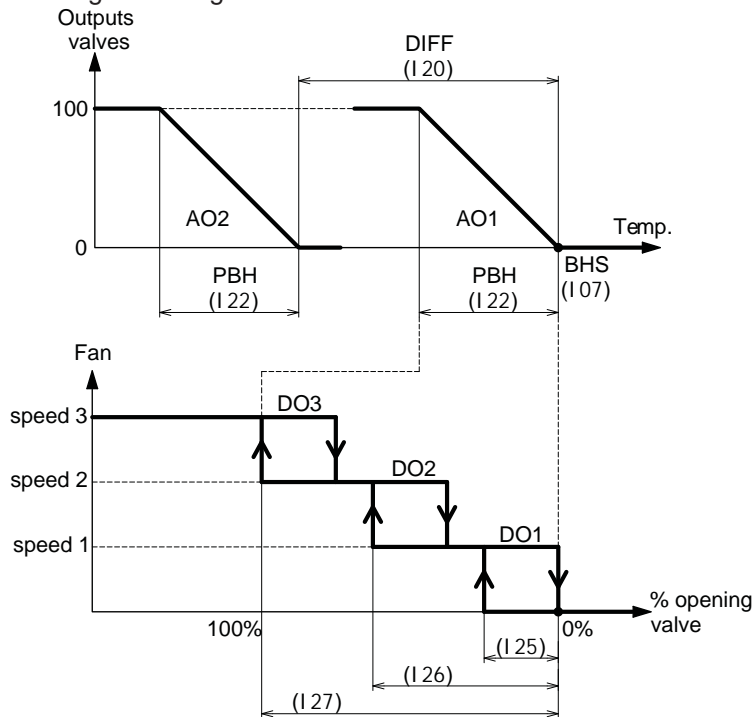

If the operating temperature drops below I07, the first valve V1 starts opening (output **AO1**). Icon turns on. The valve can be regulated with PI action if the integral time I24 is non-zero or with only proportional action if I24=0.

The fan starts when the valve reaches the aperture defined in I25 and after startup delay I36.

If the temperature continues falling, the speed switches from speed 1 to speed 2 when valve V1 reaches the aperture given in I26. The speed switches from speed 2 to speed 3 when valve V1 reaches the aperture given in I27.

Each speed is subject to a hysteresis of 20% of its activation point.

For example, for speed 3:

if I27=100%, speed 3 is activated when the valve reaches fully open and is deactivated when the valve closes by 20% of I27, which is 80% of fully open in this case.

If the temperature drops below I07 - I20, the second valve V2 opens (output **AO2**). This is regulated with proportional action.

If the temperature drops below I07 - I20 - I22, valve V2

is fully open.

Icon turns off when valve V1 closes again, in which case the fan stops if I28=0 or 2. The fan maintains speed 1 if I28=1 or 3.

The fan maintains speed selected manually if I28=4 or 6.

N.B.: if the minimum thermostat function is active, the thermostat itself must be closed when the valve is in regulation, otherwise the fan will not start.

Wiring diagram

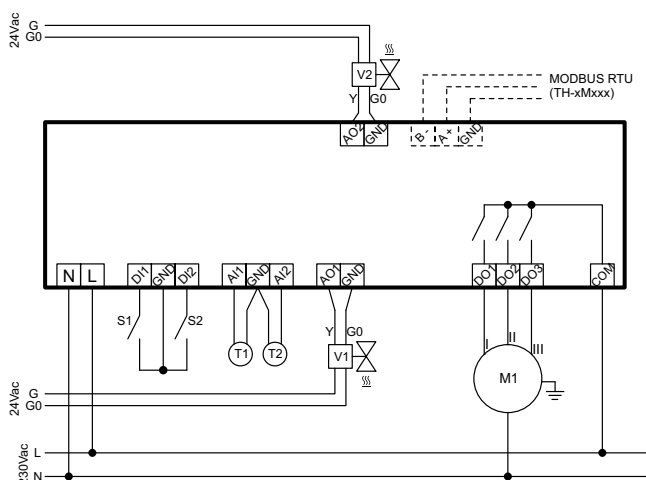

• 2 PIPE HEATING/COOLING mode with AUTOMATIC SEASON CHANGEOVER (M01=2):

The mode is selected automatically by the water sensor. Use a remote sensor for this function. Set parameters M07=1 or M09=1 or M11=1 and set the water sensor's thresholds to define the function with parameters I 15 and I 16. Select the mode of automatic season changeover between the following graphs by parameter I 54.

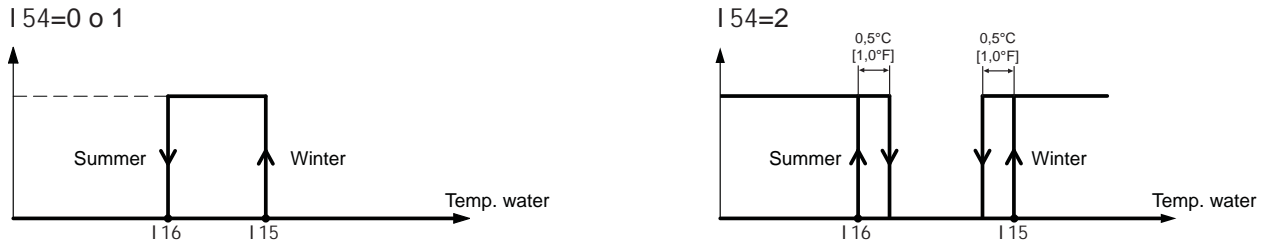

When the unit is turned on, if the water sensor temperature is between I 16 and I 15, see paragraph "12. Automatic season changeover with water sensor (M01=2 or 5)" page 24 for working season definition.

N.B.: if no remote sensor is configured as water sensor for season changeover function, the operating mode is not defined and the regulation does not start.

• 2 PIPE HEATING/COOLING mode with SEASON CHANGEOVER by CONTACT (M01=3):

The season is selected by the position of remote contact **DI1** or **DI2** configured with the "remote contact season changeover" function. Configure one of the digital contacts as shown in the following table.

M03 (or M05)=0 Remote season changeover contact	M04 (or M06)=	0	1
	Summer		
	Winter		

If the digital contacts are used for other functions, you can use a remote sensor input as "remote contact season changeover" by configuring one of the remote sensors as shown in the table.

M07 (M09 or M11)=0 Remote season changeover contact	M08 (M10 or M12)=	0	1
	Summer		
	Winter		

N.B.: if no digital contact and no remote sensor are configured as "remote contact season changeover", the operating mode is heating.

• 2 PIPE HEATING/COOLING with SEASON CHANGEOVER by PARAMETER (M01=4):

The season is selected manually (see "MODE button functionality" page 9).

Once you have made the selection, either "HEAT" or "COOL" is displayed, depending on the mode.

Heating regulation is controlled as follows for 2 pipe heating/cooling mode (M01=2, 3, 4):

The "HEAT" icon is on to indicate that heating mode is active.

The regulation logic is as follows:

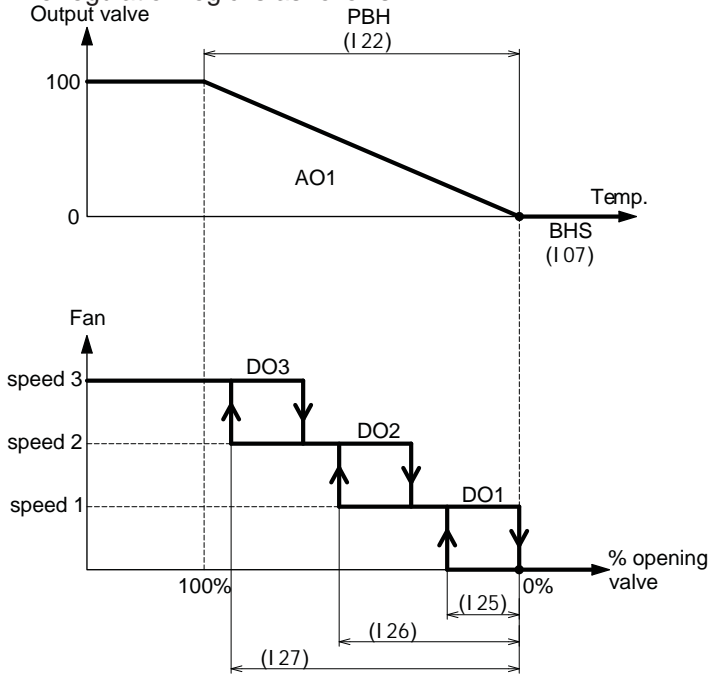

If the operating temperature drops below I 07, the valve starts opening (output **AO1**). Icon ☹ turns on. The valve can be regulated with PI action if the integral time I 24 is non-zero or with only proportional action if I 24=0. The fan starts when the valve reaches the aperture defined in I 25 and after startup delay I 36. If the temperature continues falling, the speed switches from speed 1 to speed 2 when the valve reaches the aperture given in I 26. The speed switches from speed 2 to speed 3 when the valve reaches the aperture given in I 27. Each speed is subject to a hysteresis of 20% of its activation point. For example, for speed 3: if I 27=100%, speed 3 is activated when the valve reaches fully open and is deactivated when the valve closes by 20% of I 27, which is 80% of fully open in this case. Icon ☹ turns off when the valve closes again, in which case the fan stops if I 28=0 or 2. The fan maintains speed 1 if I 28=1 or 3. The fan maintains speed selected manually if I 28=4 or 6.

N.B.: if the minimum thermostat function is in use, the thermostat itself must be closed when the valve is in regulation, otherwise the fan will not start.

Cooling regulation is controlled as follows for 2 pipe heating/cooling mode (M01=2, 3, 4):

The “**COOL**” icon is on to indicate that cooling mode is active.

The regulation logic is as follows:

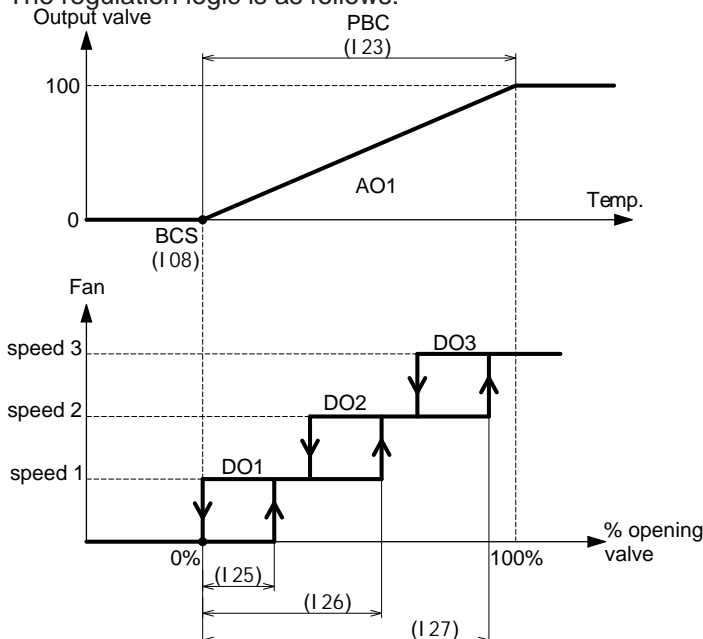

If the operating temperature rises above I 08 the valve starts opening (output **AO1**). Icon ❄ turns on. The valve can be regulated with PI action if the integral time I 24 is non-zero or with only proportional action if I 24=0.

The fan starts when the valve reaches the aperture defined in I 25 and after startup delay I 36.
 If the temperature continues increasing, the speed switches from speed 1 to speed 2 when the valve reaches the aperture given in I 26. The speed switches from speed 2 to speed 3 when the valve reaches the aperture given in I 27.
 Each speed is subject to a hysteresis of 20% of its activation point.
 For example, for speed 3:
 if I 27=100%, speed 3 is activated when the valve reaches fully open and is deactivated when the valve closes by 20% of I 27, which is 80% of fully open in this case.

Icon  turns off when the valve closes again, in which case the fan stops if I 28=0 or 3. The fan maintains speed 1 if I 28=1 or 2. The fan maintains speed selected manually if I 28=4 or 5.

Wiring diagram

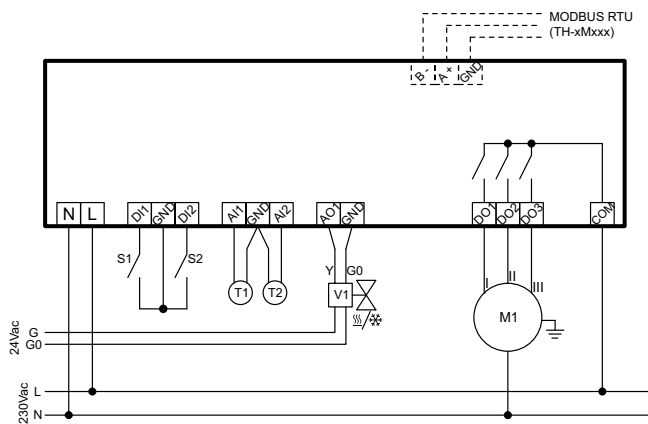



TH-3xxSx1

• **4 PIPE HEATING/COOLING mode (M01=8)**

The mode is selected automatically in relation to the operating temperature (see "11. Regulation sensor(s)" page 24). If the operating temperature is greater than $I09 + (I21 : 2)$ the icon "COOL" turns on to indicate that cooling mode is active.

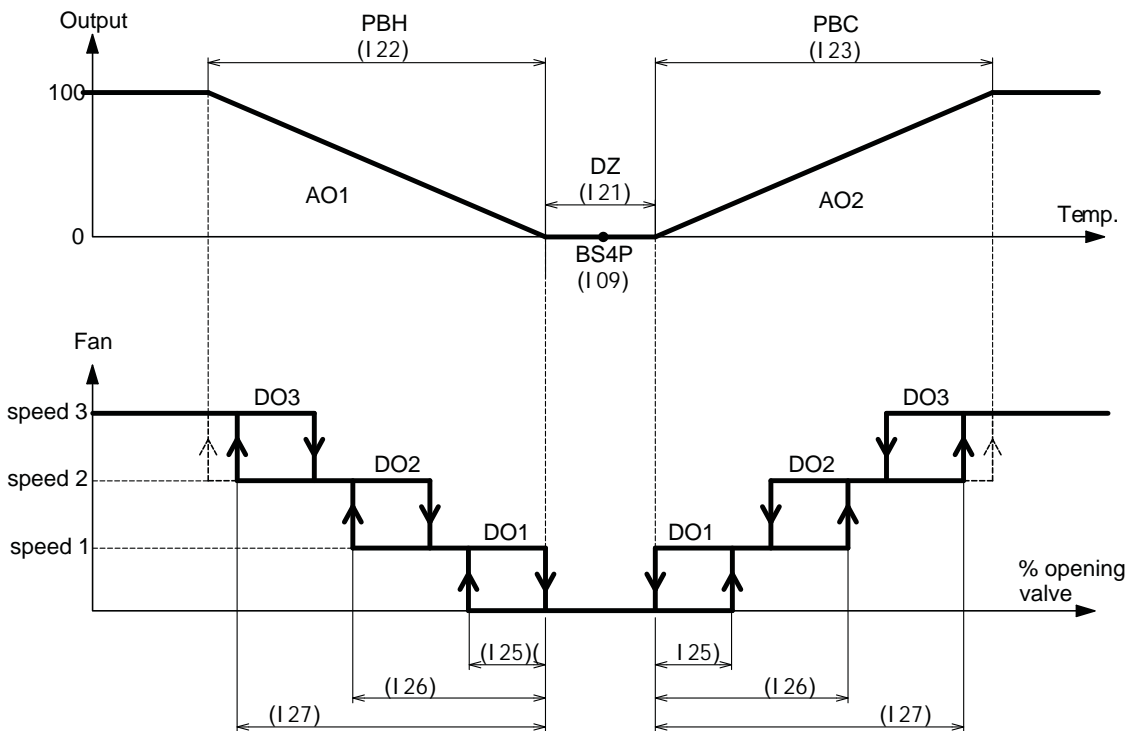
If the operating temperature is lower than $I09 - (I21 : 2)$ the icon "HEAT" turns on to indicate that heating mode is active. At startup, if the operating temperature is in the neutral zone, the "HEAT" icon turns on.



If the operating temperature drops below $I09 - (I21 : 2)$ the heating valve starts to open (output **AO1**). Icon  turns on. The valve can be regulated with PI action if the integral time I24 is non-zero or with only proportional action if I24=0. The fan starts when the valve reaches the aperture defined in I25 and after startup delay I36.

If the temperature continues falling, the speed switches from speed 1 to speed 2 when the valve reaches the aperture given in I26. The speed switches from speed 2 to speed 3 when the valve reaches the aperture given in I27. Each speed is subject to a hysteresis of 20% of its activation point.

For example, for speed 3:

if $I27=100\%$, speed 3 is activated when the valve reaches fully open and is deactivated when the valve closes by 20% of I27, which is 80% of fully open in this case.

Icon  turns off if the heating valve closes again, at which point the fan stops if I28=0 or 2. The fan maintains speed 1 if I28=1 or 3.

The fan maintains speed selected manually if I28=4 or 6.

N.B.: if the minimum thermostat function is active, the thermostat itself must be closed when the valve is in regulation, otherwise the fan will not start.

If the operating temperature rises above $I09 + (I21 : 2)$ the cooling valve starts to open (output **AO2**). Icon  turns on. The valve can be regulated with PI action if the integral time I24 is non-zero or with only proportional action if I24=0. The fan starts when the valve reaches the aperture defined in I25 and after startup delay I36.

If the temperature continues increasing, the speed switches from speed 1 to speed 2 when the valve reaches the aperture given in I26. The speed switches from speed 2 to speed 3 when the valve reaches the aperture given in I27. Each speed is subject to a hysteresis of 20% of its activation point.

For example, for speed 3:

if I 27=100%, speed 3 is activated when the valve reaches fully open and is deactivated when the valve closes by 20% of I 27, which is 80% of fully open in this case.

Icon  turns off if the cooling valve closes again, at which point the fan stops if I 28=0 or 3. The fan maintains speed 1 if I 28=1 or 2. The fan maintains speed selected manually if I 28=4 or 5.

Wiring diagram

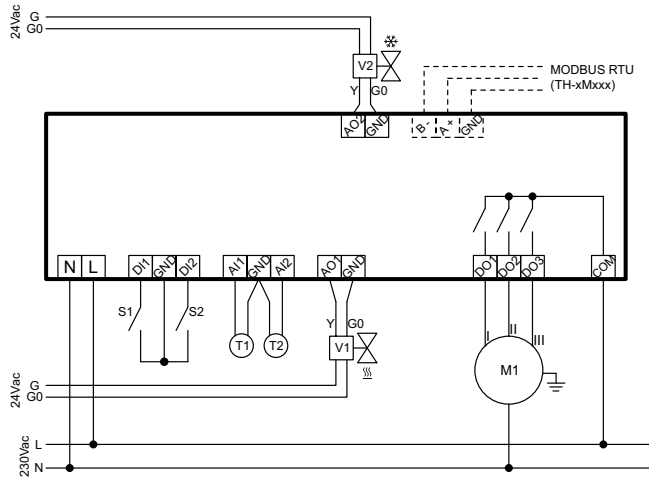

TH-3xxSx1

• **COOLING mode (M01=10)**

The “COOL” icon is on to indicate that cooling mode is active.

The regulation logic is as follows:

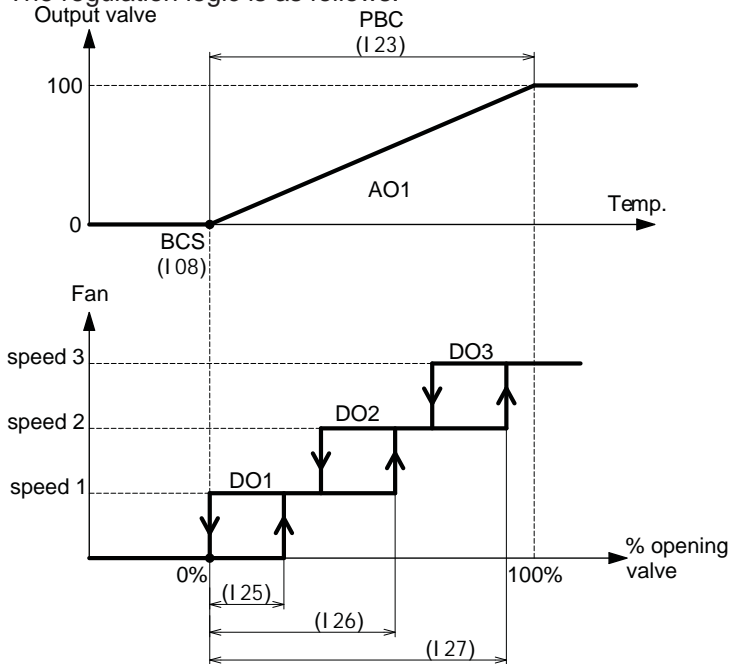

If the operating temperature rises above I 08 the valve starts opening (output **AO1**). Icon ❄ turns on.

The valve can be regulated with PI action if the integral time I 24 is non-zero or with only proportional action if I 24=0.

The fan starts when the valve reaches the aperture defined in I 25 and after startup delay I 36.

If the temperature continues increasing, the speed switches from speed 1 to speed 2 when the valve reaches the aperture given in I 26. The speed switches from speed 2 to speed 3 when the valve reaches the aperture given in I 27.

Each speed is subject to a hysteresis of 20% of its activation point.

For example, for speed 3:

if I 27=100%, speed 3 is activated when the valve reaches fully open and is deactivated when the valve closes by 20% of I 27, which is 80% of fully open in this case.

Icon ❄ turns off when the valve closes again, in which case the fan stops if I 28=0 or 3. The fan maintains speed 1 if I 28=1 or 2. The fan maintains speed selected manually if I 28=4 or 5.

Wiring diagram

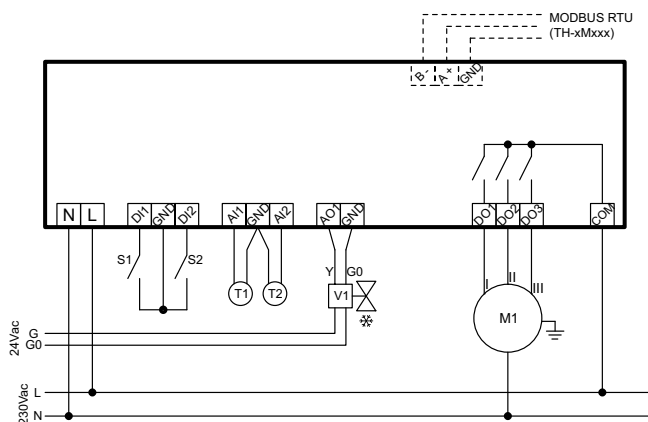

TH-3xxSx1

• COOLING/COOLING mode (M01=11)

The “COOL” icon is on to indicate that cooling mode is active.
 The regulation logic is as follows:

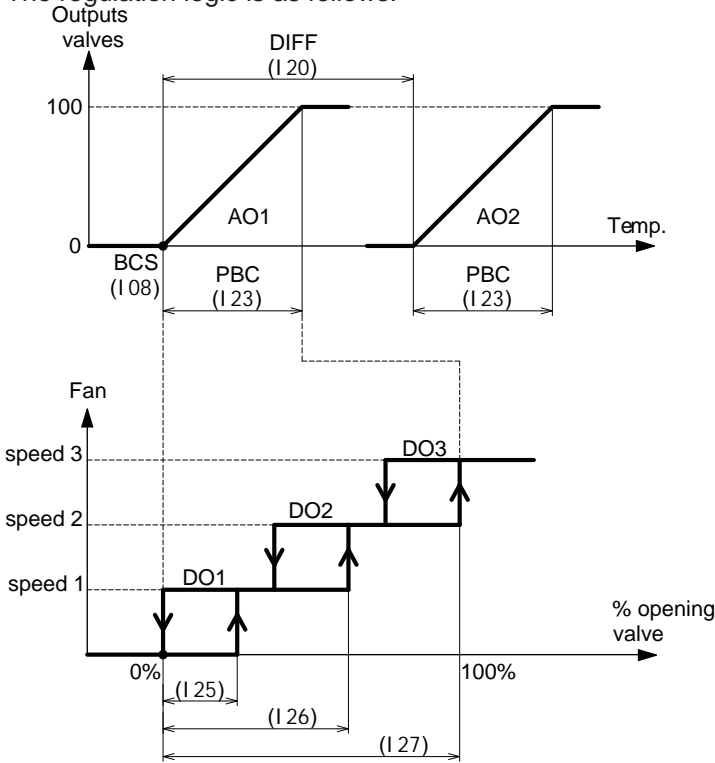

If the operating temperature rises above I 08 the first valve V1 starts opening (output **AO1**). Icon ❄ turns on.
 The valve can be regulated with PI action if the integral time I 24 is non-zero or with only proportional action if I 24=0.
 The fan starts when the valve reaches the aperture defined in I 25 and after startup delay I 36.
 If the temperature continues rising, the speed switches from speed 1 to speed 2 when valve V1 reaches the aperture given in I 26. The speed switches from speed 2 to speed 3 when valve V1 reaches the aperture given in I 27.
 Each speed is subject to a hysteresis of 20% of its activation point.
 For example, for speed 3:
 if I 27=100%, speed 3 is activated when the valve reaches fully open and is deactivated when the valve closes by 20% of I 27, which is 80% of fully open in this case.
 If the temperature drops below I 08 + I 20, the second valve V2 opens (output **AO2**). This is regulated with proportional action.
 If the temperature rises above I 08 + I 20 + I 23, valve V2 is fully open.
 Icon ❄ turns off when valve V1 closes again, in which case the fan stops if I 28=0 or 3. The fan maintains speed 1 if I 28=1 or 2. The fan maintains speed selected manually if I 28=4 or 5.

Wiring diagram

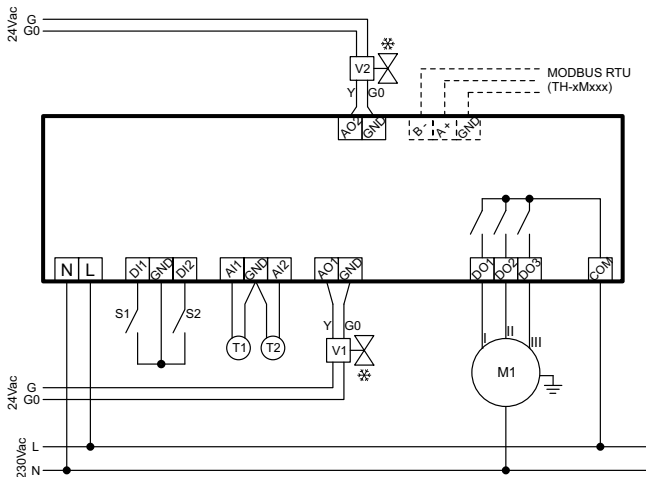

Speed 1 is activated and deactivated together with the heating output.

The hysteresis of speeds 2 and 3 is calculated automatically at 20% of the FB band (see "3 speed on-off motor speed control logic with on/off outputs" page 29).

Example: if $I 18=0.5^{\circ}\text{C}$, $\text{FB}=2^{\circ}\text{C}$, the hysteresis of speeds 2 and 3 is 0.4°C .

N.B.: if the minimum thermostat function is active, the thermostat itself must be closed when the valve is in regulation, otherwise the fan will not start. If the electric resistance is on, the fan starts immediately regardless of the position of the minimum thermostat,

- parameter I 25 is not used.

Wiring diagram

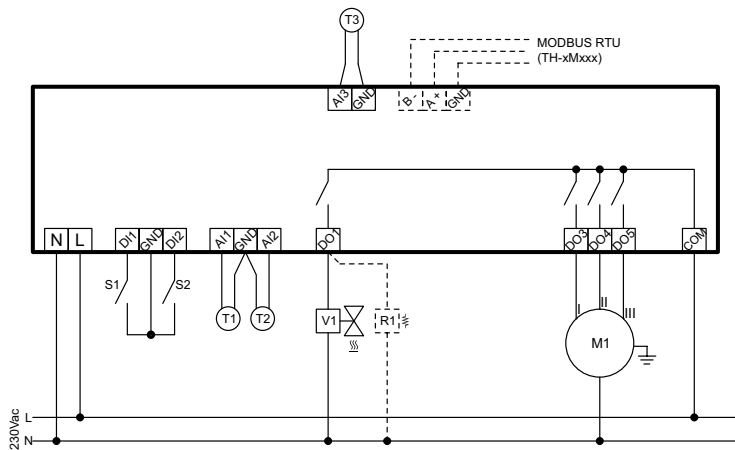

TH-4xxSx1

• HEATING/HEATING mode (M01=1)

The "HEAT" icon is on to indicate that heating mode is active.

The regulation logic is as follows:

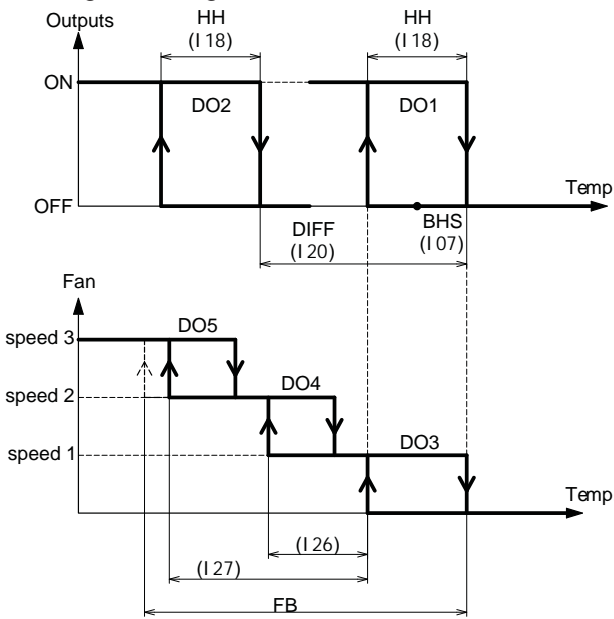

If the operating temperature drops below $I07 - (I18 : 2)$ relay **DO1** is activated.

Icon turns on if M02=2 and icons and both turn on if M02=1 or 3.

The fan starts at speed 1, after the startup delay I36, if M02=2.

The fan starts at speed 1 immediately, regardless of the startup delay I36 if M02=1 or 3.

If the temperature continues to fall, the speeds switch as follows:

- speed 1 to speed 2, when the temperature drops below $I07 - (I18 : 2) - [I26 \times (FB - I18)]$,
- speed 2 to speed 3, when the temperature drops below $I07 - (I18 : 2) - [I27 \times (FB - I18)]$.

If the operating temperature drops below $I07 - (I18 : 2) - I20$, stage 2 is activated (output **DO2**)

If the temperature rises above $I07 + (I18 : 2) - I20$, stage 2 is deactivated. If M02=2, icon turns off.

If the operating temperature increases to $I07 - (I18 : 2)$ the speed remains constant at speed 1, until the operating temperature exceeds $I07 + (I18 : 2)$

Icons and now turn off and, depending on the value of I28, the fan turns off after delay I35 or stays on for air recirculation:

if $I28=0$ or 2, the fan stops after delay I35.

if $I28=1$ or 3, the fan stays on at speed 1.

if $I28=4$ or 6, the fan stays on at speed selected manually.

Speed 1 is activated and deactivated together with the heating output.

The hysteresis of speeds 2 and 3 is calculated automatically at 20% of the FB band (see "3 speed on-off motor speed control logic with on/off outputs" page 29).

Example: if $I18=0.5^{\circ}\text{C}$, $FB=2^{\circ}\text{C}$, the hysteresis of speeds 2 and 3 is 0.4°C .

N.B.: if the minimum thermostat function is active, the thermostat itself must be closed when the valve is in regulation, otherwise the fan will not start. If, on the other hand, the electric resistance turns on, the fan starts immediately regardless of the position of the minimum thermostat.

- parameter I25 is not used.

Wiring diagram

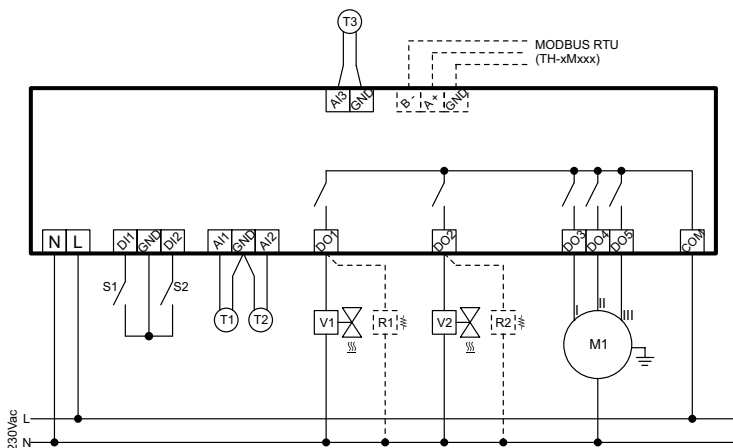

• 2 PIPE HEATING/COOLING mode with AUTOMATIC SEASON CHANGEOVER (M01=2):

The mode is selected automatically by the water sensor. Use a remote sensor for this function. Set parameters M07=1 or M09=1 or M11=1 and set the water sensor's thresholds to define the function with parameters I 15 and I 16. Select the mode of automatic season changeover between the following graphs by parameter I 54.

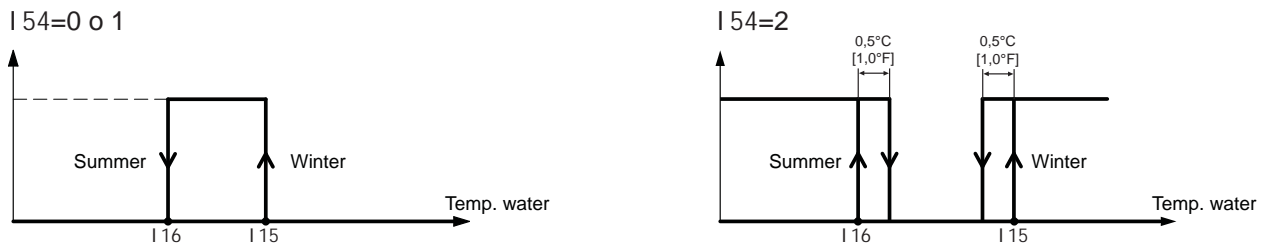

When the unit is turned on, if the water sensor temperature is between I 16 and I 15, see paragraph "12. Automatic season changeover with water sensor (M01=2 or 5)" page 24 for working season definition.

N.B.: if no remote sensor is configured as water sensor for season changeover function, the operating mode is not defined and the regulation does not start.

• 2 PIPE HEATING/COOLING mode with SEASON CHANGEOVER by CONTACT (M01=3):

The season is selected by the position of remote contact **DI1** or **DI2** configured with the "remote contact season changeover" function. Configure one of the digital contacts as shown in the following table.

M03 (or M05)=0 Remote season changeover contact	M04 (or M06)=	0	1
	Summer		
	Winter		

If the digital contacts are used for other functions, you can use a remote sensor input as "remote contact season changeover" by configuring one of the remote sensors as shown in the table.

M07 (M09 or M11)=0 Remote season changeover contact	M08 (M10 or M12)=	0	1
	Summer		
	Winter		

N.B.: if no digital contact and no remote sensor are configured as "remote contact season changeover", the operating mode is heating.

• 2 PIPE HEATING/COOLING with SEASON CHANGEOVER by PARAMETER (M01=4):

The season is selected manually (see "MODE button functionality" page 9).

Once you have made the selection, either **"HEAT"** or **"COOL"** is displayed, depending on the mode.

Heating regulation is controlled as follows for 2 pipe heating/cooling mode (M01=2, 3, 4):

The **"HEAT"** icon is on to indicate that heating mode is active.

The regulation logic is as follows (I53=0, without pump):

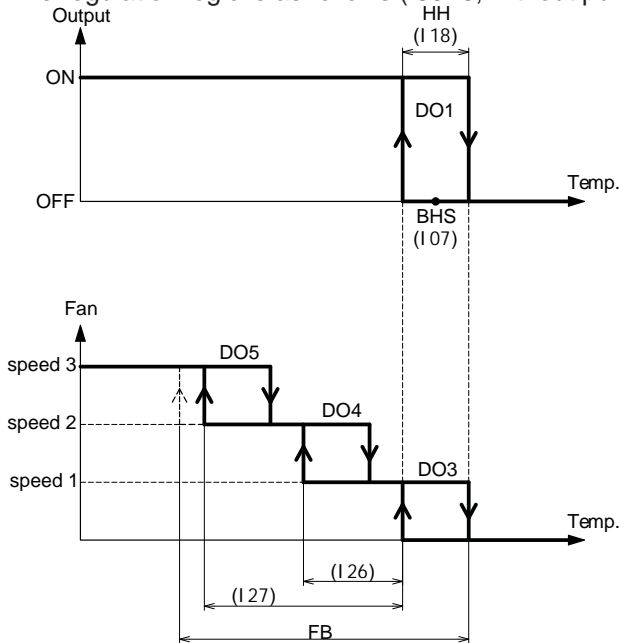

- Operation with M02=0 or 2 (digital output **DO1** does not control an electric resistance).

If the operating temperature drops below I 07 - (I 18 : 2) relay **DO1** is activated and the fan starts at speed 1 after startup delay I 36.

If the temperature continues to fall, the speeds switch as follows:

- speed 1 to speed 2, when the temperature drops below I 07 - (I 18 : 2) - [I 26 x (FB - I 18)],
- speed 2 to speed 3, when the temperature drops below I 07 - (I 18 : 2) - [I 27 x (FB - I 18)].

The icon  turns on to indicate that heating is active.

If the operating temperature increases to I 07 - (I 18 : 2) the speed remains constant at speed 1 until the operating temperature rises above I 07 + (I 18 : 2).

At this point, icon  turns off and, depending on the value of parameter I 28, the fan either stops or continues running:

- if I 28=0 or 2, the fan stops,
- if I 28=1 or 3, the fan stays on at speed 1.
- if I 28=4 or 6, the fan stays on at speed selected manually.

- Operation with M02=1 or 3 (digital output **DO1** controls an electric resistance).



If the operating temperature drops below I 07 - (I 18 : 2) relay **DO1** is activated and the fan starts immediately at speed 1 regardless of the startup delay I 36.

If the temperature continues to fall, the speeds switch as follows:

- the speed switches from speed 1 to speed 2 when the temperature drops below I 07 - (I 18 : 2) - [I 26 x (FB - I 18)],
- the speed switches from speed 2 to speed 3 when the temperature drops below I 07 - (I 18 : 2) - [I 27 x (FB - I 18)].

Icons  and  turn on to indicate heating active with electric resistance.

If the operating temperature increases to I 07 - (I 18 : 2) the speed remains constant at speed 1, until the operating temperature exceeds I 07 + (I 18 : 2).

Icons  and  now turn off and, depending on the value of I 28, the fan turns off after delay I 35 or stays on for air recirculation:

- if I 28=0 or 2, the fan stops after delay I 35.
- if I 28=1 or 3, the fan stays on at speed 1.
- if I 28=4 or 6, the fan stays on at speed selected manually.

Speed 1 is activated and deactivated together with the heating output.

The hysteresis of speeds 2 and 3 is calculated automatically at 20% of the FB band (see ["3 speed on-off motor speed control logic with on/off outputs" page 29](#)).

Example: if I 18=0.5°C, FB=2°C, the hysteresis of speeds 2 and 3 is 0.4°C.

N.B.: if the minimum thermostat function is active, the thermostat itself must be closed when the valve is in regulation, otherwise the fan will not start. If the electric resistance is on, the fan starts immediately regardless of the position of the minimum thermostat,

- parameter I 25 is not used.

Cooling regulation is controlled as follows for 2 pipe heating/cooling mode (M01=2, 3, 4):

The **"COOL"** icon is on to indicate that cooling mode is active.

The regulation logic is as follows (I53=0, without pump):

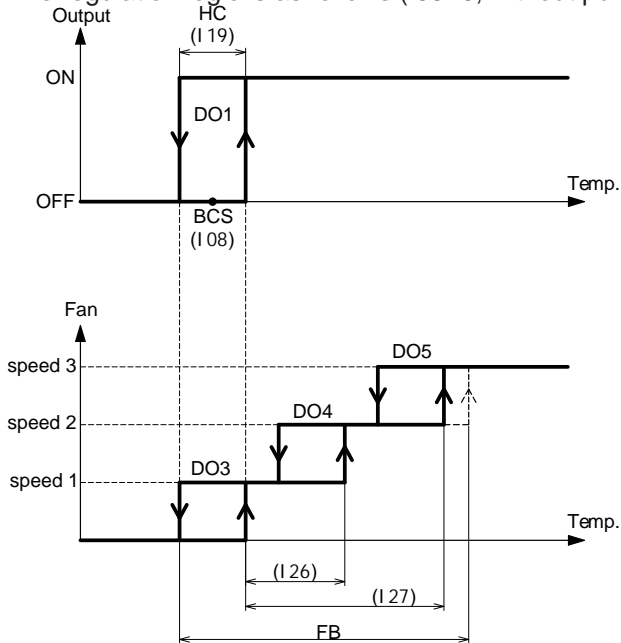

If the operating temperature rises above $I08 + (I19 : 2)$ relay **DO1** is activated and the fan starts at speed 1 after startup delay I36.

If the temperature continues to rise, the speeds switch as follows:

- speed switches from speed 1 to speed 2 when the temperature rises above $I08 + (I19 : 2) + [I26 \times (FB - I19)]$,
- speed switches from speed 2 to speed 3 if the temperature rises above $I08 + (I19 : 2) + [I27 \times (FB - I19)]$.

The icon ❄️ turns on to indicate that cooling mode is active.

If the operating temperature drops to $I08 + (I19 : 2)$ the speed remains constant at speed 1 until the operating temperature drops below $I08 - (I19 : 2)$.

At this point, icon ❄️ turns off and, depending on the value of parameter I28, the fan either stops or continues running:

- if I28=0 or 3, the fan stops,
- if I28=1 or 2, the fan stays on at speed 1.
- if I28=4 or 5, the fan stays on at speed selected manually.

Speed 1 is activated and deactivated together with the cooling output.

The hysteresis of speeds 2 and 3 is calculated automatically at 20% of the FB band (see [“3 speed on-off motor speed control logic with on/off outputs” page 29](#)).

Example: if I18=0.5°C, FB=2°C, the hysteresis of speeds 2 and 3 is 0.4°C.

N.B.: parameter I25 is not used.

If I53=1, operating mode is the same as before and is added the circulation pump P1 (**DO2**) that is driven together with the valve V1 (**DO1**)

Wiring diagram

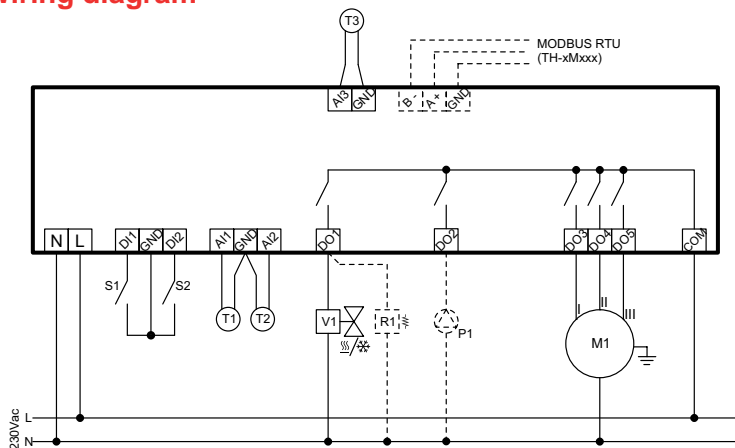

TH-4xxSx1

• **2 PIPE HEATING/COOLING + ELECTRIC RESISTANCE mode with AUTOMATIC SEASON CHANGEOVER (M01=5):**

The mode is selected automatically by the water sensor. Use a remote sensor for this function. Set parameters M07=1 or M09=1 or M11=1 and set the water sensor's thresholds to define the function with parameters I 15 and I 16. Select the mode of automatic season changeover between the following graphs by parameter I 54.

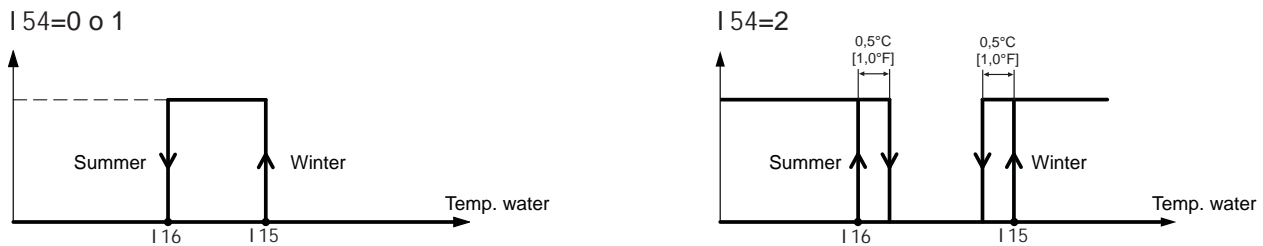

When the unit is turned on, if the water sensor temperature is between I 16 and I 15, see paragraph [“12. Automatic season changeover with water sensor \(M01=2 or 5\)” page 24](#) for working season definition.

N.B.: if no remote sensor is configured as water sensor for season changeover function, the operating mode is not defined and the regulation does not start.

• **2 PIPE HEATING/COOLING + ELECTRIC RESISTANCE mode with SEASON CHANGEOVER by CONTACT (M01=6):**

The season is selected by the position of remote contact **DI1** or **DI2** configured with the “remote contact season changeover” function. Configure one of the digital contacts as shown in the following table.

M03 (or M05)=0 Remote season changeover contact	M04 (or M06)=	0	1
	Summer		
	Winter		

If the digital contacts are used for other functions, you can use a remote sensor input as “remote contact season changeover” by configuring one of the remote sensors as shown in the table.

M07 (M09 or M11)=0 Remote season changeover contact	M08 (M10 or M12)=	0	1
	Summer		
	Winter		

N.B.: if no digital contact and no remote sensor are configured as “remote contact season changeover”, the operating mode is heating.

• **2 PIPE HEATING/COOLING + ELECTRIC RESISTANCE mode with SEASON CHANGEOVER by PARAMETER (M01=7):**

The season is selected manually (see [“MODE button functionality” page 9](#)).

Once you have made the selection, either “**HEAT**” or “**COOL**” is displayed, depending on the mode.

Heating regulation is controlled as follows for 2 pipe heating/cooling mode (M01=5, 6, 7):

The “**HEAT**” icon is on to indicate that heating mode is active.

The regulation logic is as follows:

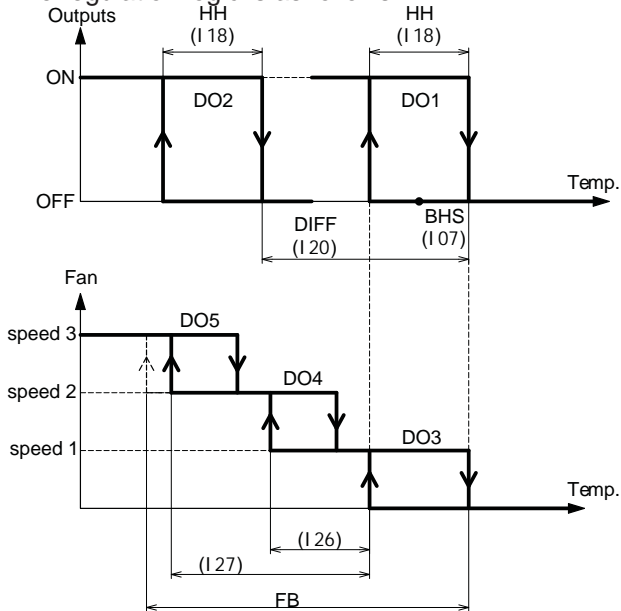

If the operating temperature drops below $I07 - (I18 : 2)$ relay **DO1** is activated.

Icon \lll turns on if $MO2=2$ and icons \lll and $\sim W$ both turn on if $MO2=1$ or 3 .

The fan starts at speed 1, after the startup delay $I36$, if $MO2=2$.

The fan starts at speed 1 immediately, regardless of the startup delay $I36$ if $MO2=1$ or 3 .

If the temperature continues to fall, the speeds switch as follows:

- the speed switches from speed 1 to speed 2 when the temperature drops below $I07 - (I18 : 2) - [I26 \times (FB - I18)]$,

- the speed switches from speed 2 to speed 3 when the temperature drops below $I07 - (I18 : 2) - [I27 \times (FB - I18)]$.

If the operating temperature drops below $I07 - (I18 : 2) - I20$, stage 2 is activated (output **DO2**)

If the temperature rises above $I07 + (I18 : 2) - I20$, stage 2 is deactivated. if $MO2=2$, icon $\sim W$ turns off.

If the operating temperature increases to $I07 - (I18 : 2)$ the speed remains constant at speed 1 until the operating temperature rises above $I07 + (I18 : 2)$.

Icon \lll , or icons \lll and $\sim W$ (if $MO2=1$ or 3) turn off and, depending on the value of $I28$, the fan turns off after delay $I35$ or stays on for air recirculation:

if $I28=0$ or 2 , the fan stops after delay $I35$.

if $I28=1$ or 3 , the fan stays on at speed 1.

if $I28=4$ or 6 , the fan stays on at speed selected manually.

Speed 1 is activated and deactivated together with the heating output.

The hysteresis of speeds 2 and 3 is calculated automatically at 20% of the FB band (see ["3 speed on-off motor speed control logic with on/off outputs" page 29](#)).

Example: if $I18=0.5^{\circ}\text{C}$, $FB=2^{\circ}\text{C}$, the hysteresis of speeds 2 and 3 is 0.4°C .

N.B.: if the minimum thermostat function is active, the thermostat itself must be closed when the valve is in regulation, otherwise the fan will not start. If the electric resistance is on, the fan starts immediately regardless of the position of the minimum thermostat,

- parameter $I25$ is not used.

Cooling regulation is controlled as follows for 2 pipe heating/cooling mode (M01=5, 6, 7):

- Operation without half season function (M15=0):

The “**COOL**” icon is on to indicate that cooling mode is active.

The regulation logic is as follows:

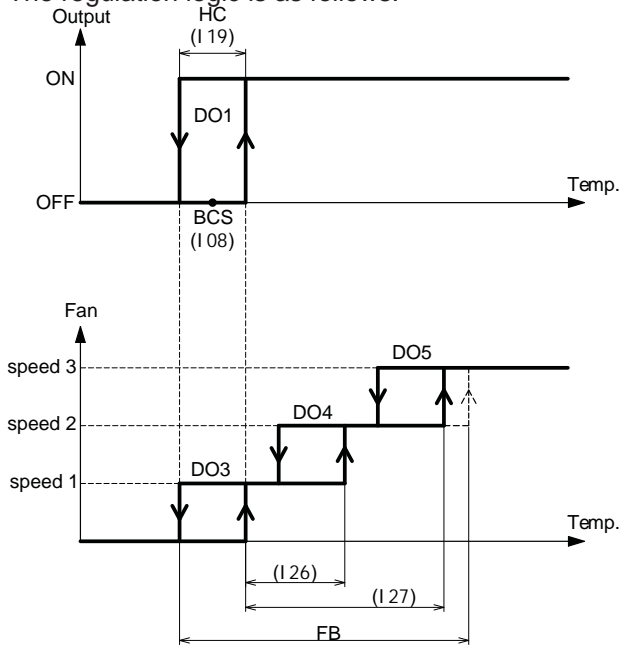

If the operating temperature rises above $I 08 + (I 19 : 2)$ relay **DO1** is activated and the fan starts at speed 1 after startup delay I 36.

If the temperature continues to rise, the speeds switch as follows:

- speed switches from speed 1 to speed 2 when the temperature rises above $I 08 + (I 19 : 2) + [I 26 \times (FB - I 19)]$,
- speed switches from speed 2 to speed 3 if the temperature rises above $I 08 + (I 19 : 2) + [I 27 \times (FB - I 19)]$.

The icon ❄️ turns on to indicate that cooling mode is active.

If the operating temperature drops to $I 08 + (I 19 : 2)$ the speed remains constant at speed 1 until the operating temperature drops below $I 08 - (I 19 : 2)$.

At this point, icon ❄️ turns off and, depending on the value of parameter I 28, the fan either stops or continues running:

- if I 28=0 or 3, the fan stops,
- if I 28=1 or 2, the fan stays on at speed 1.
- if I 28=4 or 5, the fan stays on at speed selected manually.

Speed 1 is activated and deactivated together with the cooling output.

The hysteresis of speeds 2 and 3 is calculated automatically at 20% of the FB band (see “3 speed on-off motor speed control logic with on/off outputs” page 29).

Example: if $I 18=0.5^{\circ}\text{C}$, $FB=2^{\circ}\text{C}$, the hysteresis of speeds 2 and 3 is 0.4°C .

N.B.: parameter I 25 is not used.

- Operation with half season function (M15=1):

The mode is selected automatically in relation to the operating temperature (see "11. Regulation sensor(s)" page 24). If the operating temperature is greater than $I08 + (I19 : 2)$, the icon "COOL" turns on to indicate that cooling mode is active.

If the operating temperature is lower than $I08 - (I19 : 2) - I21 - I18$, the icon "HEAT" turns on to indicate that heating mode is active.

At startup, if the operating temperature is in the neutral zone, the "HEAT" icon turns on.

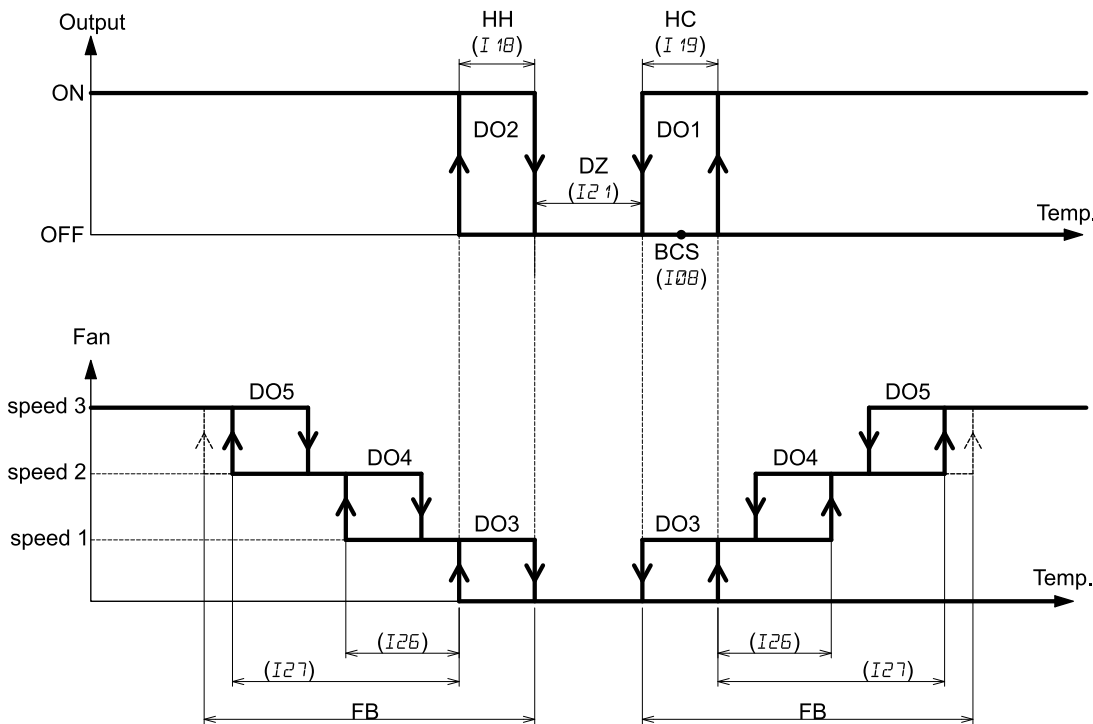

If the operating temperature drops below $I08 - (I19 : 2) - I21 - I18$ relay **DO2** is activated and the fan starts immediately at speed 1, regardless of the startup delay I 36.

If the temperature continues to fall, the speeds switch as follows:

- the speed switches from speed 1 to speed 2 when the temperature drops below $I08 - (I19 : 2) - I21 - I18 - [I26 \times (FB - I18)]$,

- the speed switches from speed 2 to speed 3 when the temperature drops below $I08 - (I19 : 2) - I21 - I18 - [I27 \times (FB - I18)]$.

Icons and turn on to indicate that heating mode with electric resistance is active.

If the operating temperature increases to $I08 - (I19 : 2) - I21 - I18$ the speed remains constant at speed 1 until the operating temperature exceeds $I08 - (I19 : 2) - I21$.

Icons and turn off and, depending on the value of I 28, the fan turns off after delay I 35 or stays on for air recirculation:

if $I28=0$ or 2, the fan stops after delay I 35.

if $I28=1$ or 3, the fan stays on at speed 1.

if $I28=4$ or 6, the fan stays on at speed selected manually.

N.B.: if the minimum thermostat function is active, the fan starts immediately regardless of the position of the minimum thermostat, when electric resistance is active.

If the operating temperature rises above $I08 + (I19 : 2)$, relay **DO1** is activated and the fan starts at speed 1 after startup delay I 36.

If the temperature continues to rise, the speeds switch as follows:

- the speed switches from speed 1 to speed 2 when the temperature rises above $I08 + (I19 : 2) + [I26 \times (FB - I19)]$,

- the speed switches from speed 2 to speed 3 when the temperature rises above $I08 + (I19 : 2) + [I27 \times (FB - I19)]$.

The icon turns on to indicate that cooling mode is active.

If the operating temperature falls to $I08 + (I19 : 2)$, the speed remains constant at speed 1 until the operating temperature drops below $I08 - (I19 : 2)$.

At this point, icon turns off and, depending on the value of parameter I 28, the fan either stops or continues running: if $I28=0$ or 3, the fan stops,

if I 28=1 or 2, the fan stays on at speed 1.

if I 28=4 or 5, the fan stays on at speed selected manually.

Speed 1 is activated and deactivated together with the heating/cooling output.

The hysteresis of speeds 2 and 3 is calculated automatically at 20% of the FB band (see "3 speed on-off motor speed control logic with on/off outputs" page 29).

Example:

if I 18=0.5°C, FB=2°C, the hysteresis of speeds 2 and 3 is 0.4°C in heating mode.

if I 19=1.0°C, FB=3°C, the hysteresis of speeds 2 and 3 is 0.6°C in cooling mode.

N.B.: parameter I 25 is not used.

Wiring diagram

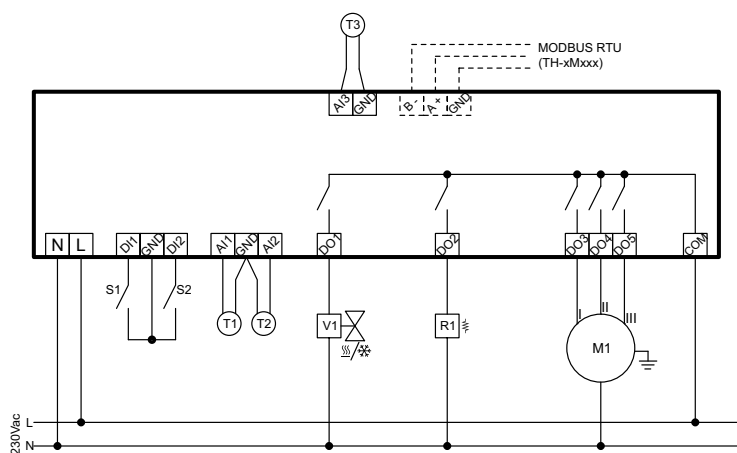

• **4 PIPE HEATING/COOLING mode (M01=8)**

The mode is selected automatically in relation to the operating temperature (see "11. Regulation sensor(s)" page 24). If the operating temperature is greater than $I 09 + (I 21 : 2) + I 19$, the icon "COOL" turns on to indicate that cooling mode is active.

If the operating temperature is lower than $I 09 - (I 21 : 2) - I 18$, the icon "HEAT" turns on to indicate that heating mode is active.

At startup, if the operating temperature is in the neutral zone, the "HEAT" icon turns on.

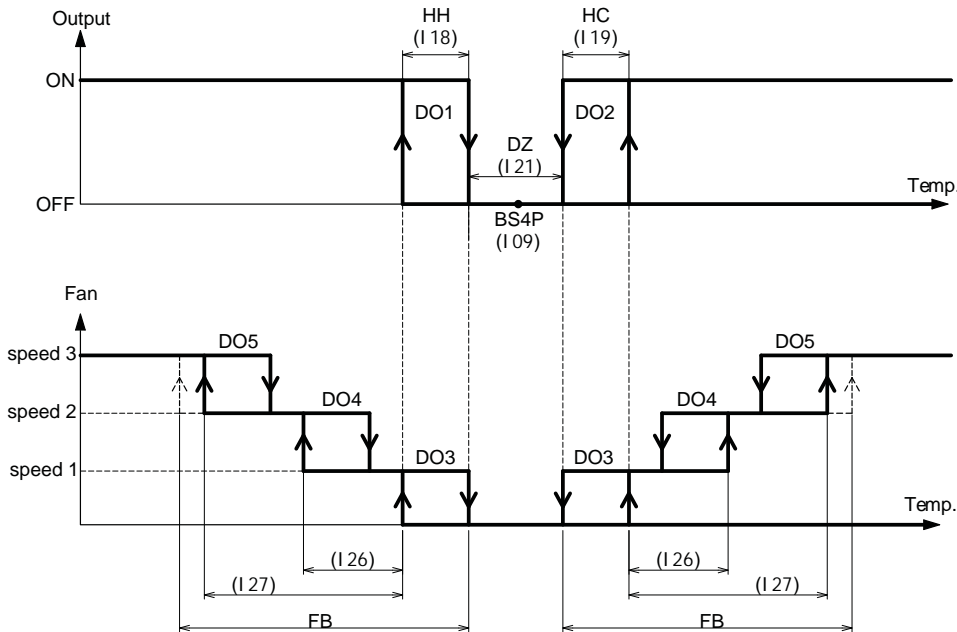

- Operation with M02=0 or 2 (digital output **DO1** does not control an electric resistance).

If the operating temperature drops below $I 09 - (I 21 : 2) - I 18$, heating relay **DO1** is activated and the fan starts at speed 1, after startup delay I 36.

- Operation with M02=1 or 3 (digital output **DO1** controls an electric resistance).

If the operating temperature drops below $I 09 - (I 21 : 2) - I 18$ relay **DO1** is activated and the fan starts immediately at speed 1, regardless of the startup delay I 36.

If the temperature continues to fall, the speeds switch as follows:

- the speed switches from speed 1 to speed 2 when the temperature drops below $I 09 - (I 21 : 2) - I 18 - [I 26 \times (FB - I 18)]$,

- the speed switches from speed 2 to speed 3 when the temperature drops below $I 09 - (I 21 : 2) - I 18 - [I 27 \times (FB - I 18)]$.

Icon turns on to indicate that heating mode is active (M02=0 or 2) or icons and turn on to indicate that heating mode with electric resistance is active (M02=1 or 3).

If the operating temperature increases to $I 09 - (I 21 : 2) - I 18$ the speed remains constant at speed 1 until the operating temperature exceeds $I 09 - (I 21 : 2)$.

Icon (M02=0 or 2) or icons and (if M02=1 or 3) turn off and, depending on the value of I 28, the fan turns off after delay I 35 or stays on for air recirculation:

if I 28=0 or 2, the fan stops after delay I 35.

if I 28=1 or 3, the fan stays on at speed 1.

if I 28=4 or 6, the fan stays on at speed selected manually.

N.B.: if the minimum thermostat function is active, the thermostat itself must be closed when the valve is in regulation, otherwise the fan will not start. If the electric resistance is on, the fan starts immediately regardless of the position of the minimum thermostat,

If the operating temperature rises above $I 09 + (I 21 : 2) + I 19$, relay **DO1** is activated and the fan starts at speed 1 after startup delay I 36.

If the temperature continues to rise, the speeds switch as follows:

- the speed switches from speed 1 to speed 2 when the temperature rises above $I 09 + (I 21 : 2) + I 19 + [I 26 \times (FB - I 19)]$,

- the speed switches from speed 2 to speed 3 when the temperature rises above $I 09 + (I 21 : 2) + I 19 + [I 27 \times (FB - I 19)]$.

The icon turns on to indicate that cooling mode is active.

If the operating temperature falls to $I 09 + (I 21 : 2) + I 19$, the speed remains constant at speed 1 until the operating temperature drops below $I 09 - (I 21 : 2)$.

At this point, icon ☼ turns off and, depending on the value of parameter I 28, the fan either stops or continues running:
 if I 28=0 or 3, the fan stops,
 if I 28=1 or 2, the fan stays on at speed 1.
 if I 28=4 or 5, the fan stays on at speed selected manually.
 Speed 1 is activated and deactivated together with the heating/cooling output.
 The hysteresis of speeds 2 and 3 is calculated automatically at 20% of the FB band (see “3 speed on-off motor speed control logic with on/off outputs” page 29).

Example:

- if I 18=0.5°C, FB=2°C, the hysteresis of speeds 2 and 3 is 0.4°C in heating mode.
- if I 19=1.0°C, FB=3°C, the hysteresis of speeds 2 and 3 is 0.6°C in cooling mode.

N.B.: parameter I 25 is not used.

Wiring diagram

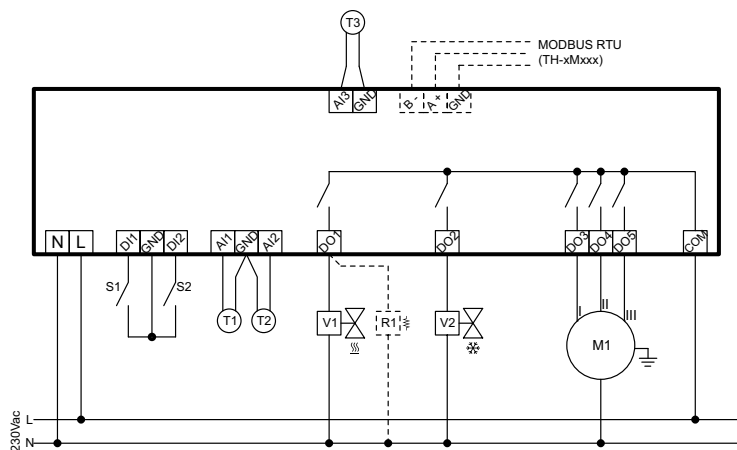

TH-4xxSx1

• **COOLING mode (M01=10)**

The “COOL” icon is on to indicate that cooling mode is active.

The regulation logic is as follows:

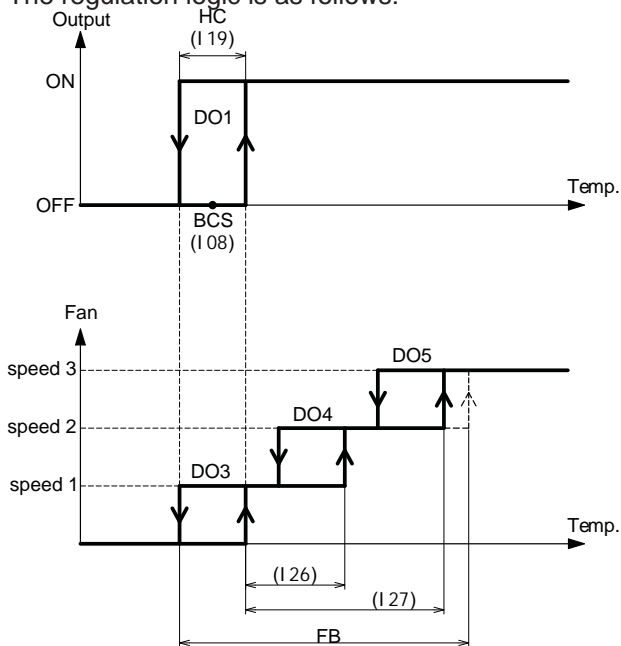

If the operating temperature rises above $I08 + (I19 : 2)$ relay **DO1** is activated and the fan starts at speed 1 after startup delay I36.

If the temperature continues to rise, the speeds switch as follows:

- the speed switches from speed 1 to speed 2 when the temperature rises above $I08 + (I19 : 2) + [I26 \times (FB - I19)]$,
- the speed switches from speed 2 to speed 3 if the temperature rises above $I08 + (I19 : 2) + [I27 \times (FB - I19)]$.

The icon  turns on to indicate that cooling mode is active.

If the operating temperature drops to $I08 + (I19 : 2)$ the speed remains constant at speed 1 until the operating temperature drops below $I08 - (I19 : 2)$.

At this point, icon  turns off and, depending on the value of parameter I28, the fan either stops or continues running:

- if $I28=0$ or 3 , the fan stops,
- if $I28=1$ or 2 , the fan stays on at speed 1.
- if $I28=4$ or 5 , the fan stays on at speed selected manually.

Speed 1 is activated and deactivated together with the cooling output.

The hysteresis of speeds 2 and 3 is calculated automatically at 20% of the FB band (see “[3 speed on-off motor speed control logic with on/off outputs](#)” page 29).

Example: if $I18=0.5^{\circ}\text{C}$, $FB=2^{\circ}\text{C}$, the hysteresis of speeds 2 and 3 is 0.4°C .

N.B.: parameter I25 is not used.

Wiring diagram

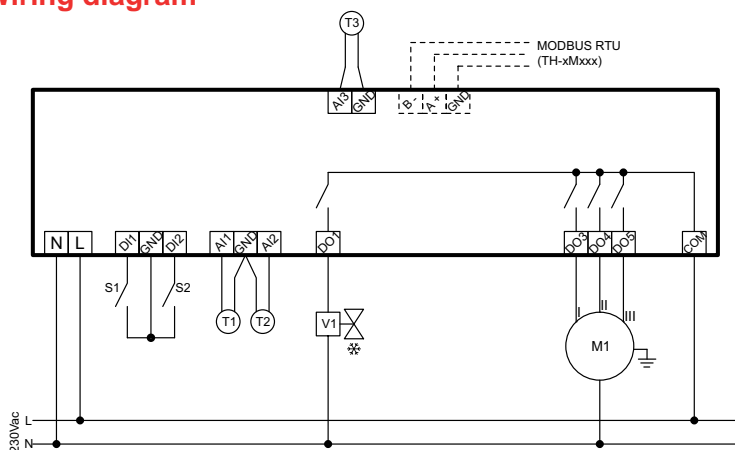

TH-4xxSx1

• **COOLING/COOLING mode (M01=11)**

The “COOL” icon is on to indicate that cooling mode is active.
The regulation logic is as follows:

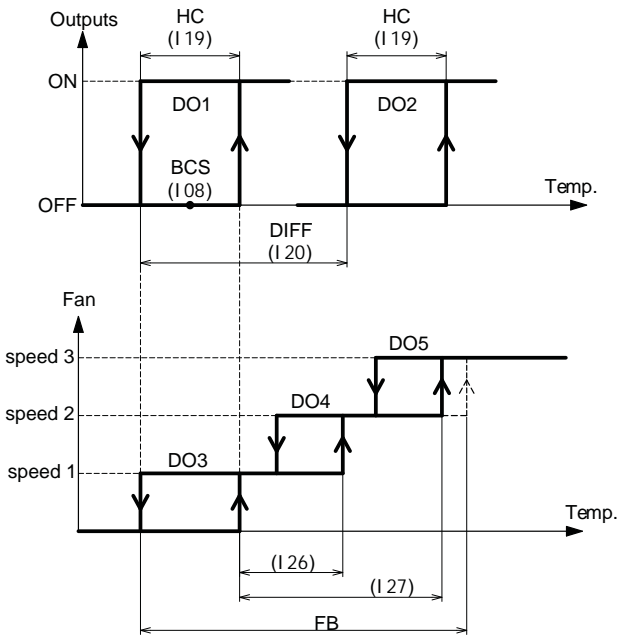

If the operating temperature rises above $I08 + (I19 : 2)$ relay **DO1** is activated and the fan starts at speed 1 after startup delay I36.

If the temperature continues to rise, the speeds switch as follows:

- the speed switches from speed 1 to speed 2 when the temperature rises above $I08 + (I19 : 2) + [I26 \times (FB - I19)]$,
- the speed switches from speed 2 to speed 3 if the temperature rises above $I08 + (I19 : 2) + [I27 \times (FB - I19)]$.

The icon ❄️ turns on to indicate that cooling mode is active.

If the operating temperature rises above $I08 + (I19 : 2) + I20$, the second cooling stage is activated (output **DO2**).

If the operating temperature drops below $I08 - (I19 : 2) + I20$, the second cooling stage is deactivated.

If the operating temperature drops to $I08 + (I19 : 2)$ the speed remains constant at speed 1 until the operating temperature drops below $I08 - (I19 : 2)$.

At this point, icon ❄️ turns off and, depending on the value of parameter I28, the fan either stops or continues running:

if $I28=0$ or 3 , the fan stops,

if $I28=1$ or 2 , the fan stays on at speed 1.

if $I28=4$ or 5 , the fan stays on at speed selected manually.

Speed 1 remains active, and is deactivated together with the cooling output.

The hysteresis of speeds 2 and 3 is calculated automatically at 20% of the FB band (see “3 speed on-off motor speed control logic with on/off outputs” page 29).

Example: if $I18=0.5^{\circ}\text{C}$, $FB=2^{\circ}\text{C}$, the hysteresis of speeds 2 and 3 is 0.4°C .

N.B.: parameter I25 is not used.

Wiring diagram

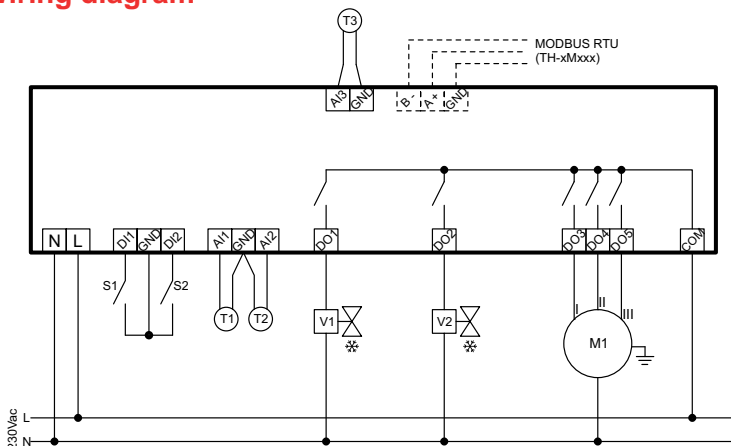

35. USB connection

The device is equipped with a USB “device” interface which can be used to configure parameters or update the software. To connect the regulator to a PC with the USB connection, use a cable with Type A connector on one end and Mini B connector on the other

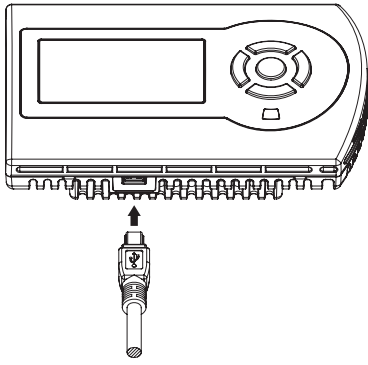

The connection can be made with the device powered up or switched off.

When the USB cable is connected to the device, the display switches off and the device is ready for configuration/update.

36. Jumper settings

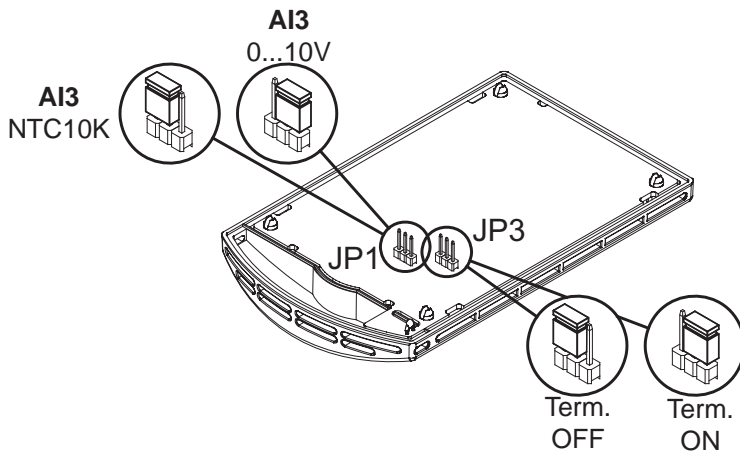

JP3=Term. ON → 120 ohm Modbus termination resistance INSERTED (model **TH-xMxSx1**).

JP3=OFF → 120 ohm Modbus termination resistance NOT INSERTED (model **TH-xMxSx1**).

JP1=position “1-2” → a third remote NTC10K remote sensor can be used for all models except for **TH-3xxSx1**

JP1=position “3-2” → the third remote sensor is 0...10v type (not used)

37. Modbus (for versions TH-xMxSx1)

The regulator implements the Modbus Slave protocol and can communicate remotely with a Modbus Master unit.

All parameters and variables are accessible as holding registers and R/W operations are implemented with function codes (FC=03, 06, 16).

The protocol can read up to 125 variables at a time.

Select a suitable timeout between readings, in relation to the baudrate.

A minimum timeout of one second is suitable for 19200 and 9600 baud. For other baudrates, increase the timeout value (2 s for 4800 baud).

Address	Description	Min	Max	R/W
3000	STATE_DI1 → 0=contact DI1 open, 1=contact DI1 closed	0	1	R
3001	STATE_DI2 → 0=contact DI2 open, 1=contact DI2 closed	0	1	R
3002	INT_TEMP_COMP → internal sensor temperature (°C [°F]) ^(Note1)	-150 [5]	900 [195]	R
3003	TEMP_AI1 → remote sensor 1 temperature (°C [°F]) ^(Note1)	-150 [5]	900 [195]	R
3004	TEMP_AI2 → remote sensor 2 temperature (°C [°F]) ^(Note1)	-150 [5]	900 [195]	R
3005	TEMP_AI3 → remote sensor 3 temperature (°C [°F]) ^(Note1)	-150 [5]	900 [195]	R
3006	INT_HUM_COMP → internal humidity (%r.h.)	0	100	R
3007	STATE_REL1 → 0=relay 1 inactive, 1=relay 1 active	0	1	R/W
3008	STATE_REL2 → 0=relay 2 inactive, 1=relay 2 active	0	1	R/W
3009	STATE_REL3 → 0=relay 3 inactive, 1=relay 3 active	0	1	R/W
3010	STATE_REL4 → 0=relay 4 inactive, 1=relay 4 active	0	1	R/W
3011	STATE_REL5 → 0=relay 5 inactive, 1=relay 5 active	0	1	R/W
3012	OUT_A → value of output AO1 (volt) ^(Note3)	0	100	R/W
3013	OUT_B → value of output AO2 (volt) ^(Note3)	0	100	R/W
3014	OUT_C → value of output AO3 (volt) ^(Note3)	0	100	R/W
3015	WORKING_TEMP → operating temperature (°C [°F]) ^(Note1)	-150	900	R
3016	WORKING_SET → operating setpoint ^(Note2)	see parameters	see parameters	R
3017	YEAR → current year	2012	2100	R
3018	MONTH → current month	1	12	R
3019	DAY → current day	1	31	R
3020	DAY_NAME → name of current day 0=Sunday 1=Monday 2=Tuesday 3=Wednesday 4=Thursday 5=Friday 6=Saturday	0	6	R
3021	HOUR → current time (hour)	0	23	R
3022	MIN → current time (min)	0	59	R
3023	SEC → current time (sec)	0	59	R
3024	TOTAL_HOUR_OF_FAN → number of hours of operation of fan (only if I 41 is non-zero, otherwise the value read is always 0)	0	9999	R
from 3025 to 3069	Reserved addresses			R
3070	FORCED_OUTPUTS_KEY → key for forced outputs selection	0 / 26312	26367	R/W
3071	0_10V_AI3 → value of measure done for input 0...10V AI3 ^(Note4)	-999	9999	R

Note 1: if sensor is broken, the temperature visualized corresponds to values indicated on the table below:

Temperature of sensor with unit in °C (I 45=0)	Value read	Value in °C
Sensor open	-200	-20.0°C
Sensor with short-circuit	970	97.0°C
Temperature of sensor with unit in °F (I 45=1)	Value read	Value in °F
Sensor open	-40	-4.0°F
Sensor with short-circuit	2066	206.6°F

Note 2: the working setpoint visualized is calculated based on parameters setting (see [“14. Working setpoint, Economy mode and holiday mode” page 25](#)). If antifreeze alarm is active or if working temperature is on alarm state, the working setpoint is forced to the following values:

Working setpoint with unit in °C (I 45=0)	Value read	Value in °C
Antifreeze alarm	700	70.0°C
Error on working temperature (heating)	-300	-30.0°C
Error on working temperature (cooling)	980	98.0°C
Working setpoint with unit in °F (I 45=1)	Value read	Value in °F
Antifreeze alarm	158	158°F
Error on working temperature (heating)	-22	-22°F
Error on working temperature (cooling)	209	209°F

Note 3: the visualised value is equal to the value in Volt multiplied per 10 (example: value 80 = 8.0 V)

Note 4: for input sensor AI3 set as 0...10V, if voltage in input is upper then 13.5V, the value 32000 corresponding to out of scale is put on Modbus

Address	Description	Default	Min	Max	R/W
2000	SUN_HOUR_ON_1 → Start of Sunday time zone 1, hour	6	0	23	R/W
2001	SUN_MIN_ON_1 → Start of Sunday time zone 1, min	0	0	59	R/W
2002	SUN_HOUR_OFF_1 → End of Sunday time zone 1, hour	8	0	23	R/W
2003	SUN_MIN_OFF_1 → End of Sunday time zone 1, min	0	0	59	R/W
2004	SUN_HOUR_ON_2 → Start of Sunday time zone 2, hour	11	0	23	R/W
2005	SUN_MIN_ON_2 → Start of Sunday time zone 2, min	0	0	59	R/W
2006	SUN_HOUR_OFF_2 → End of Sunday time zone 2, hour	13	0	23	R/W
2007	SUN_MIN_OFF_2 → End of Sunday time zone 2, min	0	0	59	R/W
2008	SUN_HOUR_ON_3 → Start of Sunday time zone 3, hour	17	0	23	R/W
2009	SUN_MIN_ON_3 → Start of Sunday time zone 3, min	0	0	59	R/W
2010	SUN_HOUR_OFF_3 → End of Sunday time zone 3, hour	19	0	23	R/W
2011	SUN_MIN_OFF_3 → End of Sunday time zone 3, min	0	0	59	R/W
2012	SUN_HOUR_ON_4 → Start of Sunday time zone 4, hour	21	0	23	R/W
2013	SUN_MIN_ON_4 → Start of Sunday time zone 4, min	0	0	59	R/W
2014	SUN_HOUR_OFF_4 → End of Sunday time zone 4, hour	23	0	23	R/W
2015	SUN_MIN_OFF_4 → End of Sunday time zone 4, min	0	0	59	R/W
2016	MON_HOUR_ON_1 → Start of Monday time zone 1, hour	6	0	23	R/W
2017	MON_MIN_ON_1 → Start of Monday time zone 1, min	0	0	59	R/W
2018	MON_HOUR_OFF_1 → End of Monday time zone 1, hour	8	0	23	R/W
2019	MON_MIN_OFF_1 → End of Monday time zone 1, min	0	0	59	R/W
2020	MON_HOUR_ON_2 → Start of Monday time zone 2, hour	11	0	23	R/W
2021	MON_MIN_ON_2 → Start of Monday time zone 2, min	0	0	59	R/W
2022	MON_HOUR_OFF_2 → End of Monday time zone 2, hour	13	0	23	R/W
2023	MON_MIN_OFF_2 → End of Monday time zone 2, min	0	0	59	R/W
2024	MON_HOUR_ON_3 → Start of Monday time zone 3, hour	17	0	23	R/W
2025	MON_MIN_ON_3 → Start of Monday time zone 3, min	0	0	59	R/W
2026	MON_HOUR_OFF_3 → End of Monday time zone 3, hour	19	0	23	R/W
2027	MON_MIN_OFF_3 → End of Monday time zone 3, min	0	0	59	R/W
2028	MON_HOUR_ON_4 → Start of Monday time zone 4, hour	21	0	23	R/W
2029	MON_MIN_ON_4 → Start of Monday time zone 4, min	0	0	59	R/W
2030	MON_HOUR_OFF_4 → End of Monday time zone 4, hour	23	0	23	R/W
2031	MON_MIN_OFF_4 → End of Monday time zone 4, min	0	0	59	R/W
2032	TUE_HOUR_ON_1 → Start of Tuesday time zone 1, hour	6	0	23	R/W
2033	TUE_MIN_ON_1 → Start of Tuesday time zone 1, min	0	0	59	R/W
2034	TUE_HOUR_OFF_1 → End of Tuesday time zone 1, hour	8	0	23	R/W
2035	TUE_MIN_OFF_1 → End of Tuesday time zone 1, min	0	0	59	R/W
2036	TUE_HOUR_ON_2 → Start of Tuesday time zone 2, hour	11	0	23	R/W
2037	TUE_MIN_ON_2 → Start of Tuesday time zone 2, min	0	0	59	R/W
2038	TUE_HOUR_OFF_2 → End of Tuesday time zone 2, hour	13	0	23	R/W
2039	TUE_MIN_OFF_2 → End of Tuesday time zone 2, min	0	0	59	R/W
2040	TUE_HOUR_ON_3 → Start of Tuesday time zone 3, hour	17	0	23	R/W
2041	TUE_MIN_ON_3 → Start of Tuesday time zone 3, min	0	0	59	R/W
2042	TUE_HOUR_OFF_3 → End of Tuesday time zone 3, hour	19	0	23	R/W

Address	Description	Default	Min	Max	R/W
2043	TUE_MIN_OFF_3 → End of Tuesday time zone 3, min	0	0	59	R/W
2044	TUE_HOUR_ON_4 → Start of Tuesday time zone 4, hour	21	0	23	R/W
2045	TUE_MIN_ON_4 → Start of Tuesday time zone 4, min	0	0	59	R/W
2046	TUE_HOUR_OFF_4 → End of Tuesday time zone 4, hour	23	0	23	R/W
2047	TUE_MIN_OFF_4 → End of Tuesday time zone 4, min	0	0	59	R/W
2048	WED_HOUR_ON_1 → Start of Wednesday time zone 1, hour	6	0	23	R/W
2049	WED_MIN_ON_1 → Start of Wednesday time zone 1, min	0	0	59	R/W
2050	WED_HOUR_OFF_1 → End of Wednesday time zone 1, hour	8	0	23	R/W
2051	WED_MIN_OFF_1 → End of Wednesday time zone 1, min	0	0	59	R/W
2052	WED_HOUR_ON_2 → Start of Wednesday time zone 2, hour	11	0	23	R/W
2053	WED_MIN_ON_2 → Start of Wednesday time zone 2, min	0	0	59	R/W
2054	WED_HOUR_OFF_2 → End of Wednesday time zone 2, hour	13	0	23	R/W
2055	WED_MIN_OFF_2 → End of Wednesday time zone 2, min	0	0	59	R/W
2056	WED_HOUR_ON_3 → Start of Wednesday time zone 3, hour	17	0	23	R/W
2057	WED_MIN_ON_3 → Start of Wednesday time zone 3, min	0	0	59	R/W
2058	WED_HOUR_OFF_3 → End of Wednesday time zone 3, hour	19	0	23	R/W
2059	WED_MIN_OFF_3 → End of Wednesday time zone 3, min	0	0	59	R/W
2060	WED_HOUR_ON_4 → Start of Wednesday time zone 4, hour	21	0	23	R/W
2061	WED_MIN_ON_4 → Start of Wednesday time zone 4, min	0	0	59	R/W
2062	WED_HOUR_OFF_4 → End of Wednesday time zone 4, hour	23	0	23	R/W
2063	WED_MIN_OFF_4 → End of Wednesday time zone 4, min	0	0	59	R/W
2064	THU_HOUR_ON_1 → Start of Thursday time zone 1, hour	6	0	23	R/W
2065	THU_MIN_ON_1 → Start of Thursday time zone 1, min	0	0	59	R/W
2066	THU_HOUR_OFF_1 → End of Thursday time zone 1, min	8	0	23	R/W
2067	THU_MIN_OFF_1 → End of Thursday time zone 1, min	0	0	59	R/W
2068	THU_HOUR_ON_2 → Start of Thursday time zone 2, hour	11	0	23	R/W
2069	THU_MIN_ON_2 → Start of Thursday time zone 2, min	0	0	59	R/W
2070	THU_HOUR_OFF_2 → End of Thursday time zone 2, hour	13	0	23	R/W
2071	THU_MIN_OFF_1 → End of Thursday time zone 2, min	0	0	59	R/W
2072	THU_HOUR_ON_3 → Start of Thursday time zone 3, hour	17	0	23	R/W
2073	THU_MIN_ON_3 → Start of Thursday time zone 3, min	0	0	59	R/W
2074	THU_HOUR_OFF_3 → End of Thursday time zone 3, hour	19	0	23	R/W
2075	THU_MIN_OFF_3 → End of Thursday time zone 3, min	0	0	59	R/W
2076	THU_HOUR_ON_4 → Start of Thursday time zone 4, hour	21	0	23	R/W
2077	THU_MIN_ON_4 → Start of Thursday time zone 4, min	0	0	59	R/W
2078	THU_HOUR_OFF_4 → End of Thursday time zone 4, hour	23	0	23	R/W
2079	THU_MIN_OFF_4 → End of Thursday time zone 4, min	0	0	59	R/W
2080	FRI_HOUR_ON_1 → Start of Friday time zone 1, hour	6	0	23	R/W
2081	FRI_MIN_ON_1 → Start of Friday time zone 1, min	0	0	59	R/W
2082	FRI_HOUR_OFF_1 → End of Friday time zone 1, hour	8	0	23	R/W
2083	FRI_MIN_OFF_1 → End of Friday time zone 1, min	0	0	59	R/W
2084	FRI_HOUR_ON_2 → Start of Friday time zone 2, hour	11	0	23	R/W
2085	FRI_MIN_ON_2 → Start of Friday time zone 2, min	0	0	59	R/W
2086	FRI_HOUR_OFF_2 → End of Friday time zone 2, hour	13	0	23	R/W
2087	FRI_MIN_OFF_2 → End of Friday time zone 2, min	0	0	59	R/W
2088	FRI_HOUR_ON_3 → Start of Friday time zone 3, hour	17	0	23	R/W
2089	FRI_MIN_ON_3 → Start of Friday time zone 3, min	0	0	59	R/W
2090	FRI_HOUR_OFF_3 → End of Friday time zone 3, hour	19	0	23	R/W
2091	FRI_MIN_OFF_3 → End of Friday time zone 3, min	0	0	59	R/W
2092	FRI_HOUR_ON_4 → Start of Friday time zone 4, hour	21	0	23	R/W
2093	FRI_MIN_ON_4 → Start of Friday time zone 4, min	0	0	59	R/W
2094	FRI_HOUR_OFF_4 → End of Friday time zone 4, hour	23	0	23	R/W
2095	FRI_MIN_OFF_4 → End of Friday time zone 4, min	0	0	59	R/W
2096	SAT_HOUR_ON_1 → Start of Saturday time zone 1, hour	6	0	23	R/W
2097	SAT_MIN_ON_1 → Start of Saturday time zone 1, min	0	0	59	R/W

Address	Description		Default	Min	Max	R/W
2098	SAT_HOUR_OFF_1 → End of Saturday time zone 1, hour		8	0	23	R/W
2099	SAT_MIN_OFF_1 → End of Saturday time zone 1, min		0	0	59	R/W
2100	SAT_HOUR_ON_2 → Start of Saturday time zone 2, hour		11	0	23	R/W
2101	SAT_MIN_ON_2 → Start of Saturday time zone 2, min		0	0	59	R/W
2102	SAT_HOUR_OFF_2 → End of Saturday time zone 2, hour		13	0	23	R/W
2103	SAT_MIN_OFF_2 → End of Saturday time zone 2, min		0	0	59	R/W
2104	SAT_HOUR_ON_3 → Start of Saturday time zone 3, hour		17	0	23	R/W
2105	SAT_MIN_ON_3 → Start of Saturday time zone 3, min		0	0	59	R/W
2106	SAT_HOUR_OFF_3 → End of Saturday time zone 3, hour		19	0	23	R/W
2107	SAT_MIN_OFF_3 → End of Saturday time zone 3, min		0	0	59	R/W
2108	SAT_HOUR_ON_4 → Start of Saturday time zone 4, hour		21	0	23	R/W
2109	SAT_MIN_ON_4 → Start of Saturday time zone 4, min		0	0	59	R/W
2110	SAT_HOUR_OFF_4 → End of Saturday time zone 4, hour		23	0	23	R/W
2111	SAT_MIN_OFF_4 → End of Saturday time zone 4, min		0	0	59	R/W
2112	TYPE_OF_HARDWARE 0=1 digital output, 3 analogue outputs 1=2 digital outputs, 2 analogue outputs 2=3 digital outputs, 1 analogue output 3=3 digital outputs, 2 analogue outputs 4=5 digital outputs	H01		0	4	R
2113	RTC_PRESENCE 0=not present 1=present	H02		0	1	R
2114	IR_PRESENCE 0=not present 1=present	H03		0	1	R
2115	HUM_PRESENCE 0=not present 1=present	H04		0	1	R
2116	TYPE_COMMUNICATION 0=not present 1=MODBUS 2=BACNET	H05		0	2	R
2117	CONTROL_STATE (see schedule page 14)	M01	4	0	11	R/W
2118	ELEC_HEATER_PRESENT (see schedule page 14)	M02	0	0	3	R/W
2119	DIG_INPUT1_FUNC (see schedule page 14)	M03	7	0	7	R/W
2120	DIG_INPUT1_LOG (see schedule page 14)	M04	0	0	1	R/W
2121	DIG_INPUT2_FUNC (see schedule page 14)	M05	7	0	7	R/W
2122	DIG_INPUT2_LOG (see schedule page 14)	M06	0	0	1	R/W
2123	ANALOG_INPUT1_FUNC (see schedule page 14)	M07	9	0	9	R/W
2124	ANALOG_INPUT1_LOG (see schedule page 14)	M08	0	0	1	R/W
2125	ANALOG_INPUT2_FUNC (see schedule page 14)	M09	9	0	9	R/W
2126	ANALOG_INPUT2_LOG (see schedule page 14)	M10	0	0	1	R/W
2127	ANALOG_INPUT3_FUNC (see schedule page 14)	M11	9	0	10	R/W
2128	ANALOG_INPUT3_LOG (see schedule page 14)	M12	0	0	1	R/W
2129	TYPE_MOTOR (see schedule page 14)	M13	0	0	1	R/W
2130	ECC_TYPE (see schedule page 14)	M14	0	0	1	R/W
2131	ACTIVE_HALF_SEASON_WORK (see schedule page 14)	M15	1	0	1	R/W
2132	COR_INT_TEMP (see schedule page 16) ($\Delta^{\circ}\text{C}$ [$\Delta^{\circ}\text{F}$]) (Note1)	I01	0	-50 [-90]	50 [90]	R/W
2133	COR_INT_HUM (see schedule page 16)	I02	0	-100	100	R/W
2134	COR_REM_AI1 (see schedule page 16) ($\Delta^{\circ}\text{C}$ [$\Delta^{\circ}\text{F}$]) (Note1)	I03	0	-50 [-90]	50 [90]	R/W
2135	COR_REM_AI2 (see schedule page 16) ($\Delta^{\circ}\text{C}$ [$\Delta^{\circ}\text{F}$]) (Note1)	I04	0	-50 [-90]	50 [90]	R/W
2136	COR_REM_AI3 (see schedule page 16) ($\Delta^{\circ}\text{C}$ [$\Delta^{\circ}\text{F}$]) (Note1)	I05	0	-50 [-90]	50 [90]	R/W
2137	WEIGHT_REM_AIR (see schedule page 16)	I06	0	0	100	R/W
2138	BASIC_HEAT_SET (see schedule page 16) ($^{\circ}\text{C}$ [$^{\circ}\text{F}$]) (Note1)	I07	200 [68]	I 11	I 10	R/W
2139	BASIC_COOL_SET (see schedule page 16) ($^{\circ}\text{C}$ [$^{\circ}\text{F}$]) (Note1)	I08	250 [77]	I 11	I 10	R/W
2140	BASIC_SET_4_PIPE (see schedule page 16) ($^{\circ}\text{C}$ [$^{\circ}\text{F}$]) (Note1)	I09	210 [70]	I 11	I 10	R/W
2141	DEV_SET_UPWARD (see schedule page 16) ($^{\circ}\text{C}$ [$^{\circ}\text{F}$]) (Note1)	I10	400 [104]	I 11	400 [104]	R/W
2142	DEV_SET_DOWNWARD (see schedule page 16) ($^{\circ}\text{C}$ [$^{\circ}\text{F}$]) (Note1)	I11	60 [43]	60 [43]	I 10	R/W

Address	Description		Default	Min	Max	R/W
2143	ECO_SET_ADJUST (see schedule page 17) ($\Delta^{\circ}\text{C}$ [$\Delta^{\circ}\text{F}$]) (Note1)	I 12	30 [5]	10 [2]	60 [11]	R/W
2144	HOL_SET_ADJUST (see schedule page 17) ($\Delta^{\circ}\text{C}$ [$\Delta^{\circ}\text{F}$]) (Note1)	I 13	50 [9]	10 [2]	100 [18]	R/W
2145	BASIC_ANTIFROST_SET (see schedule page 17) ($^{\circ}\text{C}$ [$^{\circ}\text{F}$]) (Note1)	I 14	50 [41]	40 [39]	100 [50]	R/W
2146	WINTER_SET_CHANGEOVER (see schedule page 17) ($^{\circ}\text{C}$ [$^{\circ}\text{F}$]) (Note1)	I 15	280 [82]	260 [79]	400 [104]	R/W
2147	SUMMER_SET_CHANGEOVER (see schedule page 17) ($^{\circ}\text{C}$ [$^{\circ}\text{F}$]) (Note1)	I 16	170 [63]	100 [50]	250 [77]	R/W
2148	SET_MIN_THERM (see schedule page 17) ($^{\circ}\text{C}$ [$^{\circ}\text{F}$]) (Note1)	I 17	210 [70]	190 [66]	500 [122]	R/W
2149	DO_HEATING_HYST (see schedule page 17) ($\Delta^{\circ}\text{C}$ [$\Delta^{\circ}\text{F}$]) (Note1)	I 18	10 [18]	5 [10]	20 [36]	R/W
2150	DO_COOLING_HYST (see schedule page 17) ($\Delta^{\circ}\text{C}$ [$\Delta^{\circ}\text{F}$]) (Note1)	I 19	10 [18]	5 [10]	20 [36]	R/W
2151	DIFF_2_STAGES (see schedule page 17) ($\Delta^{\circ}\text{C}$ [$\Delta^{\circ}\text{F}$]) (Note1)	I 20	20 [36]	0 [0]	30 [54]	R/W
2152	DEAD_ZONE (see schedule page 17) ($\Delta^{\circ}\text{C}$ [$\Delta^{\circ}\text{F}$]) (Note1)	I 21	5 [10]	5 [10]	50 [90]	R/W
2153	PROP_BAND_HEAT (see schedule page 17) ($\Delta^{\circ}\text{C}$ [$\Delta^{\circ}\text{F}$]) (Note1)	I 22	20 [36]	10 [18]	50 [90]	R/W
2154	PROP_BAND_COOL (see schedule page 17) ($\Delta^{\circ}\text{C}$ [$\Delta^{\circ}\text{F}$]) (Note1)	I 23	20 [36]	10 [18]	50 [90]	R/W
2155	INTEGRAL_TIME (see schedule page 17)	I 24	0	0	999	R/W
2156	SW_PT_FAN_1 (see schedule page 17)	I 25	10	1	15	R/W
2157	SW_PT_FAN_2 (see schedule page 17)	I 26	65	30	75	R/W
2158	SW_PT_FAN_3 (see schedule page 17)	I 27	100	80	100	R/W
2159	MIN_FAN_SPEED_OFF (see schedule page 17)	I 28	0	0	6	R/W
2160	EC_MIN_START_VOLT (see schedule page 17) (Note2)	I 29	10	0	130	R/W
2161	EC_MAX_VOLT (see schedule page 17) (Note2)	I 30	80	129	100	R/W
2162	EC_SW_PT_FAN (see schedule page 17)	I 31	10	0	100	R/W
2163	SPEED_EC_1 (see schedule page 17)	I 32	10	0	15	R/W
2164	SPEED_EC_2 (see schedule page 17)	I 33	65	30	75	R/W
2165	SPEED_EC_3 (see schedule page 17)	I 34	100	80	100	R/W
2166	HEATER_STOP_FAN_DELAY (see schedule page 17)	I 35	30	0	600	R/W
2167	FAN_START_DELAY (see schedule page 17)	I 36	0	0	600	R/W
2168	FAN_START_BOOSTER (see schedule page 17)	I 37	1	0	1	R/W
2169	AIR_DESTRAT_ACTIVATE (see schedule page 17)	I 38	1	0	3	R/W
2170	TIME_DELAY_ON_DESTRAT (see schedule page 17)	I 39	1	1	5	R/W
2171	TIME_DELAY_OFF_DESTRAT (see schedule page 17)	I 40	10	1	60	R/W
2172	MAX_HOUR_FAN_RUN (see schedule page 17)	I 41	2000	0	9990	R/W
2173	VISU_TYPE_FIST_DISP (see schedule page 17)	I 42	0	0	9	R/W
2174	VISU_TYPE_SECOND_DISP (see schedule page 17)	I 43	10	0	13	R/W
2175	FUNCTION_RIGHT_KEY (see schedule page 17)	I 44	0	0	2	R/W
2176	UNIT_C_F (see schedule page 17) (Note1)	I 45	0	0	1	R/W
2177	DAYLIGHT_SAVING_TIME (see schedule page 17)	I 46	1	0	2	R/W
2178	TIME_TIMER_PROLUNG (see schedule page 17)	I 47	60	1	480	R/W
2179	MODBUS_BAUD (see schedule page 17)	I 48	4	1	5	R/W
2180	MODBUS_PARITY (see schedule page 17)	I 49	2	0	2	R/W
2181	MODBUS_ADDRESS (see schedule page 17)	I 50	1	1	247	R/W
2182	CANCEL_HOURS_FAN_RUN (see schedule page 17)	I 51	0	0	1	R/W
2183	COMFORT_FUNCTION (see schedule page 17)	I 52	0	0	1	R/W
2184	OFFSET_SETPOINT ($\Delta^{\circ}\text{C}$ [$\Delta^{\circ}\text{F}$]) (Note1)		0 [0]	-30 [-50]	30 [50]	R/W
2185	MODE_FASCE 0=operation without time zones 1=operation with time zones 2=economy holiday mode		0	0	2	R/W
2186	MANUAL_OCCUPANCY 0=timer extension off 1=timer extension on		0	0	1	R/W
2187	STA_MANUAL 0=winter 1=summer		0	0	1	R/W

Address	Description	Default	Min	Max	R/W	
2188	FAN_SPEED_MODE 0=manual speed 1 1=manual speed 2 2=manual speed 3 3=automatic speed	3	0	3	R/W	
2189	ON_OFF_MANUAL 0= OFF, 1= ON	1	0	1	R/W	
2190	YEAR_SET → year to set	2012	2012	2100	R/W	
2191	MONTH_SET → month to set	1	1	12	R/W	
2192	DAY_SET → day to set	1	1	31	R/W	
2193	HOUR_SET → time to set (hour)	0	0	23	R/W	
2194	MIN_SET → time to set (min)	0	0	59	R/W	
2195	ABI_CLOCK_SET_FROM_MODBUS → to update the clock via Modbus, set the year, month, day, hour, minutes in order with addresses 2190 to 2194. The set ABI_CLOCK_SET_FROM_MODBUS=1. The settings are automatically loaded into the device and ABI_CLOCK_SET_FROM_MODBUS is reset to 0.	0	0	1	R/W	
2196	RESET_PARAM_TO_DEFAULT → set parameter to 1 to reload the default settings. The parameter resets to 0 once the procedure has terminated successfully	0	0	1	R/W	
2197	LOCK_KEYBOARD 0= keyboard not locked 1= keyboard locked	0	0	1	R/W	
from 2198 to 2209	Reserved addresses (DEBUG)				R/W	
2210	Major version of software (factory set)	-	-	-	R	
2211	Minor version of software (factory set)	-	-	-	R	
2212	Patch level of software (factory set)	-	-	-	R	
2213	PUMP_RELAY (see schedule page 16)	I 53	0	0	1	R/W
2214	SEASON_BETWEEN_2P (see schedule page 16)	I 54	0	0	2	R/W
2215	RANGE_MIN_VOLT_INPUT (see schedule page 16)	I 55	0	-50	I 56	R/W
2216	RANGE_MAX_VOLT_INPUT (see schedule page 16)	I 56	2000	I 55	9999	R/W
2217	UNIT_VOLT_INPUT (see schedule page 16)	I 57	0	0	2	R/W
2218	COR_AI3_VOLT_INPUT (see schedule page 16)	I 58	0	-980	980	R/W
2219	ABIL_FAN (see schedule page 16) 0= fan not used 1= fan used	I 59	1	0	1	R/W

Note 1: set all temperature parameters with the same unit as parameter UNIT_C_F

The values are visualised multiplied by 10. For the setpoints in °F, the parameters I 12 and I 13 in °F and the OFFSET SETPOINT in °F, values visualised are real values.

Note 2: the visualised value is equal to the value in Volt multiplied per 10 (example: value 80 = 8.0 V)

• **Default parameters reset via MODBUS**

The initial (default) configuration of the parameters can be reloaded as follows:

Set RESET_PARAM_TO_DEFAULT at address 2196 to 1.

The reset procedure starts. The display reports the following messages:

 Loading default settings...

 Default settings loaded

When the default settings have been loading, the regulator returns to regulation mode and the register RESET_PARAM_TO_DEFAULT in address 2196 resets to 0.

- **Clock setting via MODBUS**

To set the clock via the ModBus, proceed as follows:

set the variables at addresses 2190 to 2194 ("YEAR_SET" to "MIN_SET"). Then set the variable at address 2195 (enable clock update) to 1.

Once the clock has been updated, the variable resets to 0 automatically.

- **MODBUS communications alarm**

If there are frequent parity or checksum errors relating to messages received from master, the icon  485 flashes on the display. Contact technical service.

• MODBUS connection diagram

These diagrams refer to models **TH-xMxSx1**.

The RS485-MODBUS line has a principal bus to which the various devices are connected (max 32 devices).

Use cables with a braided pair + 1 ground wire + shield.

Use the braided pair to connect **A+** and **B-** and the single wire for **GND** which must be connected to each device.

Connect the shield to ground at a single point, preferably near the master.

The cable must be of the MODBUS RS485 data transmission type.

The ends of the cable must be connected with a 120 ohm termination resistance.

To fit the 120 ohm to the regulator, see *"36. Jumper settings" page 104*.

The maximum length of the bus depends on the baudrate and the cable itself.

For a baudrate of 9600, the cable (AVG26 type) can be up to 1000 m long.

Any branch lines must be short, not more than 20 m long. If you use a multi-port tap for n branches, each branch can be up to 40 m divided by n.

To increase the number of devices on the line or increase the length of the cables, you must install a signal repeater. Add a signal repeater for every group of 32 connected devices.

Connection without repeater:

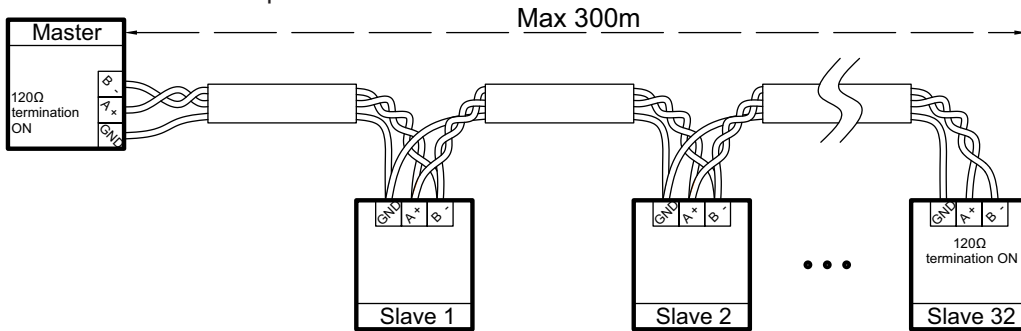

Connection with repeater:

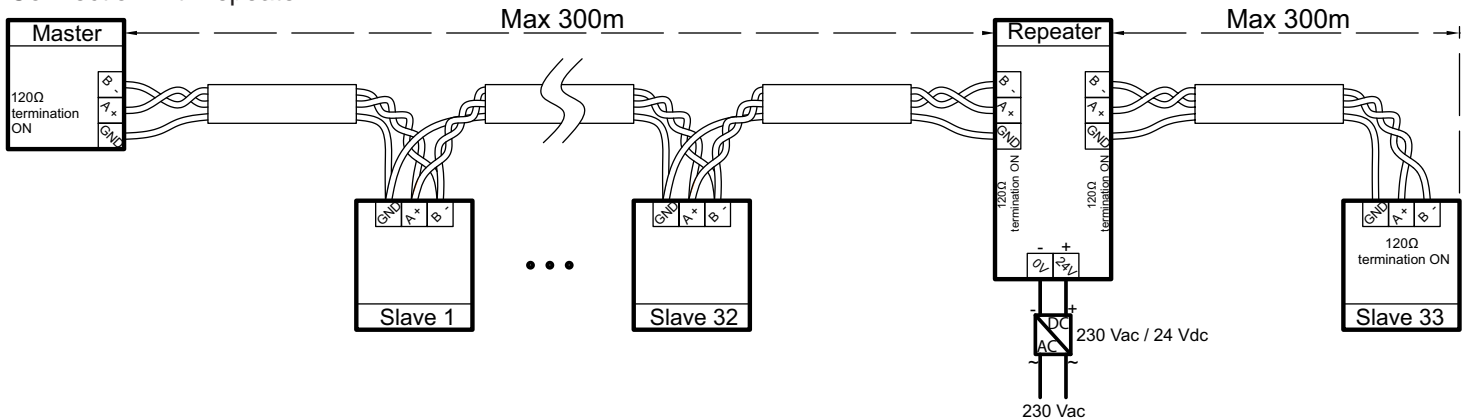

38. BACnet (for versions TH-xBxSx1)

On BACnet communication the baudrate can be set and each byte of data is encoded as follow:
1 start bit, 8 bit data, 1 stop bit, no parity.

• BACnet connection diagram

These diagrams refer to models **TH-xBxSx1**.

The RS485 line has a principal bus to which the various devices are connected (max 32 devices).

Use cables with a braided pair + 1 ground wire + shield.

Use the braided pair to connect **A+** and **B-** and the single wire for **GND** which must be connected to each device.
Connect the shield to ground at a single point.

The cable must be of the RS485 data transmission type.

The ends of the cable must be connected with a 120 ohm termination resistance.

To fit the 120 ohm to the regulator, see "36. Jumper settings" page 104.

The maximum length of the bus depends on the baudrate and the cable itself.

For a baudrate of 9600, the cable (AVG26 type) can be up to 1000 m long.

Any branch lines must be short, not more than 20 m long. If you use a multi-port tap for n branches, each branch can be up to 40 m divided by n.

To increase the number of devices on the line or increase the length of the cables, you must install a signal repeater.
Add a signal repeater for every group of 32 connected devices.

Connection without repeater:

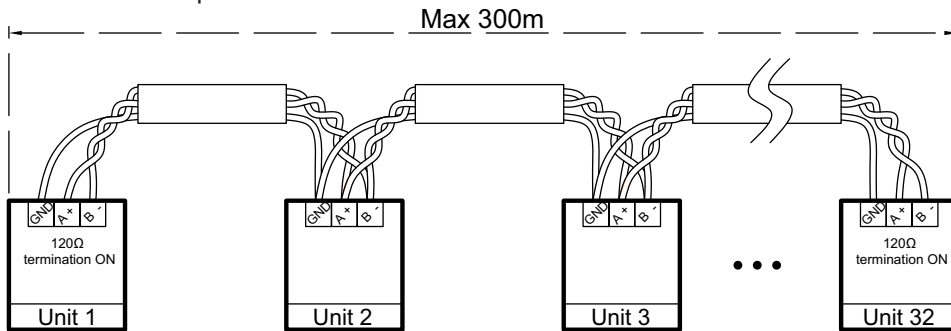

Connection with repeater:

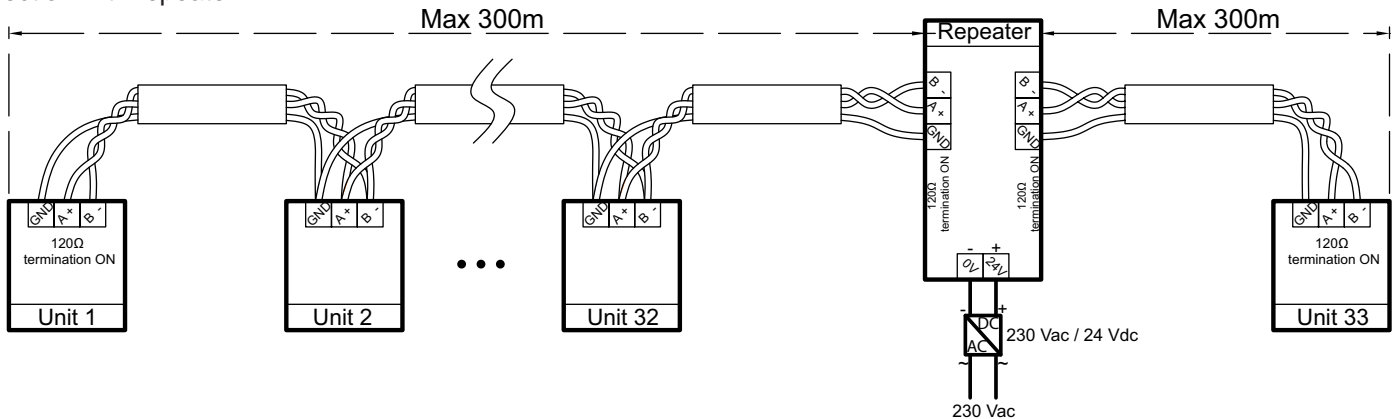

• BACnet protocol implementation conformance statement

Product description

Date	26/05/2015
Vendor name	AB Industrietechnik Srl (belongs to AB REGIN group)
Vendor ID	670
Product name	Evolution
Product model number	TH-xBxSx1
Application software version	1.1.0
Firmware revision	3.2.0.6
BACnet protocol version	1
BACnet protocol revision	12

BACnet Standardized Device Profile (Annex L)

- BACnet Operator Workstation (B-OWS)
- BACnet Advanced Operator Workstation (B-AWS)
- BACnet Operator Display (B-OD)
- BACnet Building Controller (B-BC)
- BACnet Advanced Application Controller (B-AAC)
- BACnet Application Specific Controller (B-ASC)
- BACnet Smart Sensor (B-SS)
- BACnet Smart Actuator (B-SA)

List of all BACnet Interoperability Building Blocks Supported (Annex K)

Data sharing	Data Sharing – ReadProperty-B	DS-RP-B
	Data Sharing – ReadPropertyMultiple-B	DS-RPM-B
	Data Sharing – WriteProperty-B	DS-WP-B
Device Management	Device Management – Dynamic Device Binding-B	DM-DDB-B
	Device Management – Dynamic Object Binding-B	DM-DOB-B
	Device Management – DeviceCommunicationControl-B	DM-DCC-B
	Device Management – TimeSynchronization-B	DM-TS-B

Segmentation Capability

- Able to transmit segmented messages
 - Able to receive segmented messages
- Window Size:
Window Size:

Standard Object Types Supported

Object type	Supported	Creatable	Deleteable
Analog Input	•		
Analog Output			
Analog Value	•		
Binary Input	•		
Binary Output			
Binary Value	•		
Calendar			
Command			
Device	•		
Event Enrollment			
File			
Group			
Loop			
Multi-State Input			
Multi-State Output			
Multi-State Value	•		
Notification Class			
Program			
Schedule			
Averaging			
Trend Log			
Life Safety Point			
Life Safety Zone			
Accumulator			
Pulse Converter			

Object type	Optional properties supported	Writeable properties (not otherwise required by the standard)	Range restrictions
Analog Input	Reliability		
Analog Value	Present_Value	Writeable	
	Min_Pres_Value *	Writeable	
	Max_Pres_Value **	Writeable	
Binary Input	Polarity	Writeable	
	Inactive_Text		
	Active_Text		
Binary Value	Present_Value	Writeable	
	Inactive_Text		
	Active_Text		
Device	Local_Time		
	Daylight_Savings_Status		
	Max_Segments_Accepted		
	APDU_Segment_Timeout		
	Max_Master		
	Max_Info_Frames		
Multistate Value	Present_Value	Writeable	
	State_Text		

* Min_Pres_Value is a property setting the possible low limit value for Present_Value of the following object: BASIC_HEAT_SET (2138), BASIC_COOL_SET (2139), BASIC_SET_4_PIPE (2140)
It corresponds to item I 11.

** Max_Pres_Value is a property setting the possible high limit value for Present_Value of the following object: BASIC_HEAT_SET (2138), BASIC_COOL_SET (2139), BASIC_SET_4_PIPE (2140)
It corresponds to item I 10.

Data Link Layer Options

- BACnet IP, (Annex J)
- BACnet IP, (Annex J), Foreign Device
- ISO 8802-3, Ethernet (Clause 7)
- ATA 878.1, 2.5 Mb. ARCNET (Clause 8)
- ATA 878.1, EIA-485 ARCNET (Clause 8), baud rate(s) _____
- MS/TP master (Clause 9), baud rate(s): 9600, 19200, 38400, 76800
- MS/TP slave (Clause 9), baud rate(s): 9600, 19200, 38400, 76800
- Point-To-Point, EIA 232 (Clause 10), baud rate(s): _____
- Point-To-Point, modem, (Clause 10), baud rate(s): _____
- LonTalk, (Clause 11), medium: _____
- BACnet/ZigBee (ANNEX O)
- Other: _____

Device Address Binding

Is static device binding supported? (This is currently necessary for two-way communication with MS/TP slaves and certain other devices.) Yes No

Networking Options

- Router, Clause 6 - List all routing configurations, e.g., ARCNET-Ethernet, Ethernet-MS/TP, etc.
- Annex H, BACnetTunneling Router over IP
- BACnet/IP Broadcast Management Device (BBMD)
 - Does the BBMD support registrations by Foreign Devices? Yes No
 - Does the BBMD support network address translation? Yes No

Network Security Options

- Non-secure Device – is capable of operating without BACnet Network Security
- Secure Device – is capable of using BACnet Network Security (NS-SD BIBB)
 - Multiple Application-Specific Keys:
 - Supports encryption (NS-ED BIBB)
 - Key Server (NS-KS BIBB)

Character Sets Supported

Indicating support for multiple character sets does not imply that they can all be supported simultaneously.

- ISO 10646 (UTF-8) IBM™/Microsoft™ DBCS ISO 8859-1
- ISO 10646 (UCS-2) ISO 10646 (UCS-4) JIS X 0208

If this product is a communication gateway, describe the types of non-BACnet equipment/networks(s) that the gateway supports:

N/a

• BACnet signals

Analogue inputs

Object name	Object-ID	Description	Unit	Writable
INT_TEMP_COMP	ANALOG_INPUT:3002	Internal sensor temperature	°C / °F	No
TEMP_AI1	ANALOG_INPUT:3003	Remote sensor 1 temperature	°C / °F	No
TEMP_AI2	ANALOG_INPUT:3004	Remote sensor 2 temperature	°C / °F	No
INPUT_AI3	ANALOG_INPUT:3005	Remote sensor 3	°C / °F ppm %r.h.	No
INT_HUM_COMP	ANALOG_INPUT:3006	Internal humidity	%r.h.	No

If a temperature sensor is broken, the temperature visualized corresponds to values indicated on the table below:

Temperature of sensor with unit in °C (I 45=0)	Value in °C
Sensor open	-20.0°C
Sensor with short-circuit	97.0°C
Temperature of sensor with unit in °F (I 45=1)	Value in °F
Sensor open	-4.0°F
Sensor with short-circuit	206.6°F

For INPUT_AI3 set as 0...10V, if voltage in input is upper then 13.5V, the value 32000 indicating out of scale is put on Present_Value if RANGE_MAX_VOLT_INPUT (Present_Value) - RANGE_MIN_VOLT_INPUT (Present_Value) is upper than 399, otherwise the value 3200 indicates out of scale.

Analogue values

Object name	Object-ID	Description	Unit	Writable
OUT_A	ANALOG_VALUE:3012	Value of output AO1	V	No
OUT_B	ANALOG_VALUE:3013	Value of output AO2	V	No
OUT_C	ANALOG_VALUE:3014	Value of output AO3	V	No
WORKING_TEMP	ANALOG_VALUE:3015	Operating temperature	°C / °F	No
WORKING_SET ^(Note 1)	ANALOG_VALUE:3016	Operating setpoint	°C / °F	No
TOTAL_HOUR_OF_FAN	ANALOG_VALUE:3024	Number of hours of operation of fan	h	No
COR_INT_TEMP ^(Note 3)	ANALOG_VALUE:2132	Internal temperature correction	°C / °F	Yes
COR_INT_HUM	ANALOG_VALUE:2133	Measured internal humidity correction	%r.h.	Yes
COR_REM_AI1 ^(Note 3)	ANALOG_VALUE:2134	External temperature correction AI1	°C / °F	Yes
COR_REM_AI2 ^(Note 3)	ANALOG_VALUE:2135	External temperature correction AI2	°C / °F	Yes
COR_REM_AI3 ^(Note 3)	ANALOG_VALUE:2136	External temperature correction AI3	°C / °F	Yes
WEIGHT_REM_AIR	ANALOG_VALUE:2137	Weighting (%) of external sensor AI1 in relation to the internal sensor	%	Yes
ECO_SET_ADJUST ^(Note 2)	ANALOG_VALUE:2143	Economy offset	°C / °F	Yes
HOL_SET_ADJUST ^(Note 2)	ANALOG_VALUE:2144	"Not occupied holiday" mode offset	°C / °F	Yes
BASIC_ANTI Frost_SET ^(Note 2)	ANALOG_VALUE:2145	Frost protection setpoint	°C / °F	Yes
WINTER_SET_CHANGE OVER ^(Note 2)	ANALOG_VALUE:2146	Heating setpoint for automatic season changeover sensor	°C / °F	Yes
SUMMER_SET_CHANGE OVER ^(Note 2)	ANALOG_VALUE:2147	Cooling setpoint for automatic season changeover sensor	°C / °F	Yes
SET_MIN_THERM ^(Note 2)	ANALOG_VALUE:2148	Minimum thermostat setpoint	°C / °F	Yes
BASIC_HEAT_SET ^(Note 2)	ANALOG_VALUE:2138	Heating setpoint for regulation other than 4 pipe system	°C / °F	Yes
BASIC_COOL_SET ^(Note 2)	ANALOG_VALUE:2139	Cooling setpoint for regulation other than 4 pipe system	°C / °F	Yes
BASIC_SET_4_PIPE ^(Note 2)	ANALOG_VALUE:2140	Setpoint for 4 pipe regulation	°C / °F	Yes
DO_HEATING_HYST ^(Note 3)	ANALOG_VALUE:2149	Heating hysteresis for on/off output	°C / °F	Yes
DO_COOLING_HYST ^(Note 3)	ANALOG_VALUE:2150	Cooling hysteresis for on/off output	°C / °F	Yes
DIFF_2_STAGES ^(Note 3)	ANALOG_VALUE:2151	Differential between 2 stages	°C / °F	Yes
DEAD_ZONE ^(Note 3)	ANALOG_VALUE:2152	Neutral zone for 4 pipe systems	°C / °F	Yes
PROP_BAND_HEAT ^(Note 3)	ANALOG_VALUE:2153	Heating proportional band	°C / °F	Yes
PROP_BAND_COOL ^(Note 3)	ANALOG_VALUE:2154	Cooling proportional band	°C / °F	Yes
INTEGRAL_TIME	ANALOG_VALUE:2155	Integral time	s	Yes
SW_PT_FAN_1	ANALOG_VALUE:2156	Speed 1 activation point for 3 speed motor	%	Yes
SW_PT_FAN_2	ANALOG_VALUE:2157	Speed 2 activation point for 3 speed motor	%	Yes
SW_PT_FAN_3	ANALOG_VALUE:2158	Speed 3 activation point for 3 speed motor	%	Yes

Object name	Object-ID	Description	Unit	Writable
EC_MIN_START_VOLT	ANALOG_VALUE:2160	Minimum EC motor starting voltage	V	Yes
EC_MAX_VOLT	ANALOG_VALUE:2161	Maximum voltage applicable to EC motor	V	Yes
EC_SW_PT_FAN	ANALOG_VALUE:2162	Starting point of EC motor in regulation	%	Yes
SPEED_EC_1	ANALOG_VALUE:2163	Speed 1 of EC motor	%	Yes
SPEED_EC_2	ANALOG_VALUE:2164	Speed 2 of EC motor	%	Yes
SPEED_EC_3	ANALOG_VALUE:2165	Speed 3 of EC motor	%	Yes
HEATER_STOP_FAN_DELAY	ANALOG_VALUE:2166	Delay on ventilation deactivation	s	Yes
FAN_START_DELAY	ANALOG_VALUE:2167	Fan start delay after valve opening	s	Yes
TIME_DELAY_ON_DESTRAT	ANALOG_VALUE:2170	Fan start time during destratification cycle	min	Yes
TIME_DELAY_OFF_DESTRAT	ANALOG_VALUE:2171	Fan stop time if regulation is not active before starting a new destratification cycle	min	Yes
MAX_HOUR_FAN_RUN	ANALOG_VALUE:2172	Maximum fan run time before filter is considered dirty	h	Yes
TIME_TIMER_PROLUNG	ANALOG_VALUE:2178	Duration of extension timer	min	Yes
OFFSET_SETPOINT ^(Note 2)	ANALOG_VALUE:2184	Offset setpoint	°C / °F	Yes
RANGE_MIN_VOLT_INPUT	ANALOG_VALUE:2215	Low limit of scale for input 0...10V	ppm %r.h -	Yes
RANGE_MAX_VOLT_INPUT	ANALOG_VALUE:2216	High limit of scale for input 0...10V	ppm %r.h -	Yes
COR_AI3_VOLT_INPUT ^(Note 4)	ANALOG_VALUE:2218	Correction for input 0...10V AI3	ppm %r.h -	Yes

Note 1: the Present_Value property of WORKING_SET is calculated based on parameters setting (see “14. Working setpoint, Economy mode and holiday mode” page 25. If antifreeze alarm is active or if working temperature is on alarm state, the Present_Value property is forced to the following values:

Present_Value with unit in °C (Present_Value of UNIT_C_F in CELCIUS)	Value in °C
Antifreeze alarm	70.0
Error on working temperature (heating)	-30.0
Error on working temperature (cooling)	98.0
Present_Value with unit in °F (Present_Value of UNIT_C_F in FARENHEIT)	Value in °F
Antifreeze alarm	158
Error on working temperature (heating)	-22
Error on working temperature (cooling)	209

Note 2: the Present_Value set is rounded to step 0,5 if Present_Value of UNIT_C_F is CELCIUS.

Note 3: the Present_Value set is rounded to step 0,2 if Present_Value of UNIT_C_F is FARENHEIT.

Note 4: For COR_AI3_VOLT_INPUT the Present_Value is truncated to unit if RANGE_MAX_VOLT_INPUT (Present_Value) - RANGE_MIN_VOLT_INPUT (Present_Value) is upper than 399, otherwise the Present_Value can be set without being truncated.

Example: if range = 2000, a value set of 1.3 is truncated to 1.0.

Binary inputs

Object name	Object-ID	Description	Values	Writable
STATE_DI1	BINARY_INPUT:3000	Digital input 1 state	ACTIVE / INACTIVE	No
STATE_DI2	BINARY_INPUT:3001	Digital input 2 state	ACTIVE / INACTIVE	No
STATE_AI1_AS_DI3	BINARY_INPUT:3003	State of analog input 1 used as digital contact	ACTIVE / INACTIVE	No
STATE_AI2_AS_DI4	BINARY_INPUT:3004	State of analog input 2 used as digital contact	ACTIVE / INACTIVE	No
STATE_AI3_AS_DI5	BINARY_INPUT:3005	State of analog input 3 used as digital contact	ACTIVE / INACTIVE	No

Binary values

Object name	Object-ID	Description	Values	Writable
STATE_REL1	BINARY_VALUE:3007	State of relay 1	ACTIVE / INACTIVE	No
STATE_REL2	BINARY_VALUE:3008	State of relay 2	ACTIVE / INACTIVE	No
STATE_REL3	BINARY_VALUE:3009	State of relay 3	ACTIVE / INACTIVE	No
STATE_REL4	BINARY_VALUE:3010	State of relay 4	ACTIVE / INACTIVE	No
STATE_REL5	BINARY_VALUE:3011	State of relay 5	ACTIVE / INACTIVE	No
TYPE_MOTOR	BINARY_VALUE:2129	Motor type	EC / 3-SPEED	Yes
ECC_TYPE	BINARY_VALUE:2130	EC motor type	STANDARD / WITH AUX RELAY	Yes
ACTIVE_HALF_SEASON_WORK	BINARY_VALUE:2131	Half season function enable	ACTIVE / INACTIVE	Yes
FAN_START_BOOSTER	BINARY_VALUE:2168	Fan boost	ACTIVE / INACTIVE	Yes
UNIT_C_F	BINARY_VALUE:2176	Unit of measurement	CELCIUS / FARENHEIT	Yes
CANCEL_HOURS_FAN_RUN	BINARY_VALUE:2182	Reset fancoil hour counter	ACTIVE / INACTIVE	Yes
COMFORT_FUNCTION	BINARY_VALUE:2183	Comfort function	ACTIVE / INACTIVE	Yes
ON_OFF_MANUAL	BINARY_VALUE:2189	Manual on / off	ON / OFF	Yes
LOCK_KEYBOARD	BINARY_VALUE:2197	Keyboard locking function	ACTIVE / INACTIVE	Yes
PUMP_RELAY	BINARY_VALUE:2213	Relay for pump	ACTIVE / INACTIVE	Yes
ABIL_FAN	BINARY_VALUE:2219	Fan activation	ACTIVE / INACTIVE	Yes

Multistate values

Object name	Object-ID	Description	Values / State text	Writable
AIR_DESTRAT_ACTIVATE	MULTISTATE_VALUE:2169	Air destratification function	1=OFF 2=ON on heat and cool 3=ON on heat 4=ON on cool	Yes
CONTROL_STATE	MULTISTATE_VALUE:2117	Unit regulation type	1=H 2=2-stage H 3=2-pipe, auto c/o 4=2-pipe, rem. contact c/o 5=2-pipe, par. c/o 6=2-pipe + R, auto c/o 7=2-pipe + R, rem. contact c/o 8=2-pipe + R, par. c/o 9=4-pipe 10=4-pipe + R 11=C 12=2-stage C	Yes
ELEC_HEATER_PRESENT	MULTISTATE_VALUE:2118	Electric resistance stage	1=No stage 2=Stage 1 3=Stage 2 4=Stage 1 and 2	Yes
DIG_INPUT1_FUNC	MULTISTATE_VALUE:2119	Digital input 1 function Digital input 1 contact logic is set on STATE_DI1 object with property Polarity	1=Remote season c/o 2=Remote on/off 3=No occupied holidays 4=Economy 5=Window contact 6=Alarm 7=Minimum thermostat contact 8=Not used	Yes
DIG_INPUT2_FUNC	MULTISTATE_VALUE:2121	Digital input 2 function Digital input 2 contact logic is set on STATE_DI2 object with property Polarity	1=Remote season c/o 2=Remote on/off 3=No occupied holidays 4=Economy 5=Window contact 6=Alarm 7=Minimum thermostat contact 8=Not used	Yes
ANALOG_INPUT1_FUNC	MULTISTATE_VALUE:2123	Analog input 1 function Analog input 1 contact logic is set on STATE_A11_AS_DI3 object with property Polarity (for values between 4 and 9)	1=Remote regulation sensor 2=Water sensor autom. season c/o 3=Minimum thermostat sensor 4=Remote season c/o 5=Remote on/off 6=No occupied holidays 7=Economy 8=Window contact 9=Alarm 10=Not used	Yes
ANALOG_INPUT2_FUNC	MULTISTATE_VALUE:2125	Analog input 2 function Analog input 2 contact logic is set on STATE_A12_AS_DI4 object with property Polarity (for values between 4 and 9)	1=Remote regulation sensor 2=Water sensor autom. season c/o 3=Minimum thermostat sensor 4=Remote season c/o 5=Remote on/off 6=No occupied holidays 7=Economy 8=Window contact 9=Alarm 10=Not used	Yes
ANALOG_INPUT3_FUNC	MULTISTATE_VALUE:2127	Analog input 3 function Analog input 3 contact logic is set on STATE_A13_AS_DI5 object with property Polarity (for values between 4 and 9)	1=Remote regulation sensor 2=Water sensor autom. season c/o 3=Minimum thermostat sensor 4=Remote season c/o 5=Remote on/off 6=No occupied holidays 7=Economy 8=Window contact 9=Alarm 10=Not used 11=0..10V	Yes
MIN_FAN_SPEED_OFF	MULTISTATE_VALUE:2159	Speed maintained when setpoint reached	1=Fan stopped at set reached 2=Speed 1 on at set reached 3=Speed 1 on at set reached C. 4=Speed 1 on at set reached H. 5=Man. speed on at set reached 6=Man. speed on at set reached C. 7=Man. speed on at set reached H.	Yes

Object name	Object-ID	Description	Values / State text	Writable
VISU_TYPE_FIRST_DISP	MULTISTATE_VALUE:2173	Value displayed on <u>display A</u>	1=Int. sensor 2=Sensor AI1 3=Sensor AI2 4=Sensor AI3 5=Operating temp. 6=Humidity sensor 7=Operating set 8=Out AO1 9=Out AO2 10=Out AO3	Yes
VISU_TYPE_SECOND_DISP	MULTISTATE_VALUE:2174	Value displayed on <u>display B</u>	1=Int. sensor 2=Sensor AI1 3=Sensor AI2 4=Sensor AI3 5=Operating temp. 6=Humidity sensor 7=Operating set 8=Out AO1 9=Out AO2 10=Out AO3 11=Hour:min 12=Fan hours 13=Input 0..10V AI3 14=Switch off	Yes
FUNCTION_RIGHT_KEY	MULTISTATE_VALUE:2175	Mode key function	1=Local season c/o 2=Timer extension 3=Operating mode	Yes
MODE_FASCE	MULTISTATE_VALUE:2185	Operating mode setting	1=Without time zone 2=With time zone 3=Not occupied mode	Yes
MANUAL_OCCUPANCY	MULTISTATE_VALUE:2186	Timer extension	1=Timer extension off 2=Timer extension on	Yes
STA_MANUAL	MULTISTATE_VALUE:2187	Working season selection Only for 2 pipe system	1=Winter 2=Summer	Yes
FAN_SPEED_MODE	MULTISTATE_VALUE:2188	Fan speed selection	1=Manual speed 1 2=Manual speed 2 3=Manual speed 3 4=Automatic speed	Yes
SEASON_BETWEEN_2P	MULTISTATE_VALUE:2214	Working season selection in 2-pipe system with water sensor temperature between I 15 and I 16	1=Winter 2=Summer 3=Not_defined	Yes
UNIT_VOLT_INPUT	MULTISTATE_VALUE:2217	Unit of measure on <u>display B</u> for input 0...10V	1=ppm 2=rh 3=No unit	Yes
DAYLIGHT_SAVINGS_MODE	MULTISTATE_VALUE:2177	Summertime changeover	1=No 2=Yes, Europe 3=Yes, USA	Yes

H=heating;
C=cooling;
R=electric heater;
c/o=season changeover;
auto=with water sensor;
rem.=with remote contact;
par.=with parameter.

Device

The device object contains no writable property.

39. Electrical connection

 Each single operation done on the unit, either installation or maintenance, must be done without main supply on the unit and external loads. Such operations are permitted only by skilled workers. Industrietechnik is not responsible for possible damages caused by an inadequate installation and/or by removed or exchanged security devices.

Connection of version TH-0xxSx1

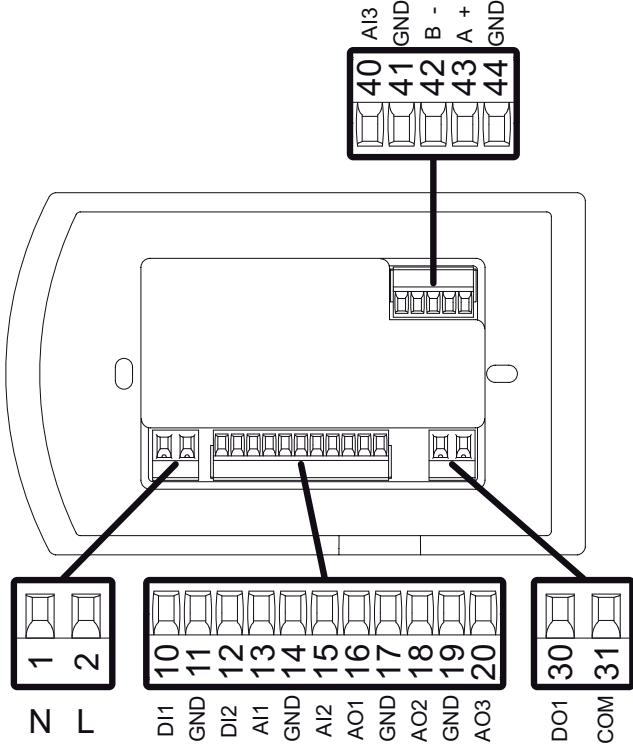

Connection of version TH-1xxSx1

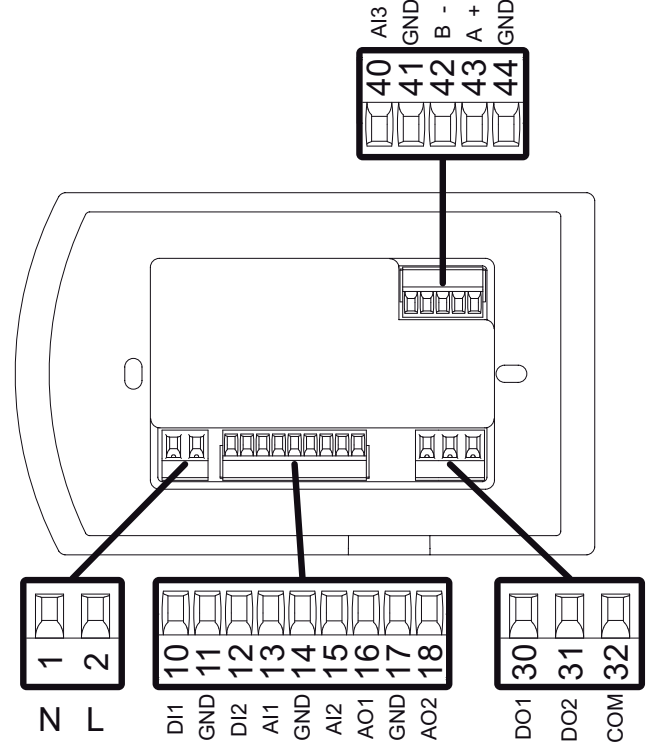

Connection of version TH-2xxSx1

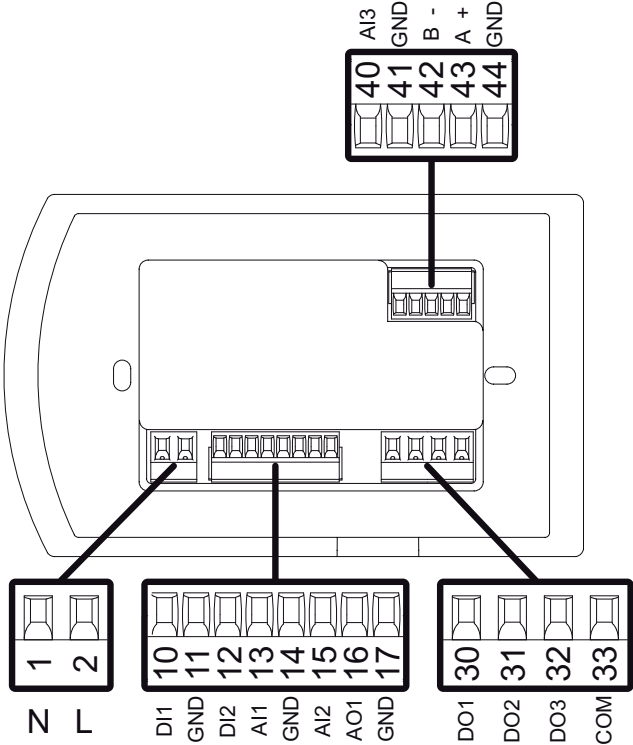

Connection of version TH-3xxSx1

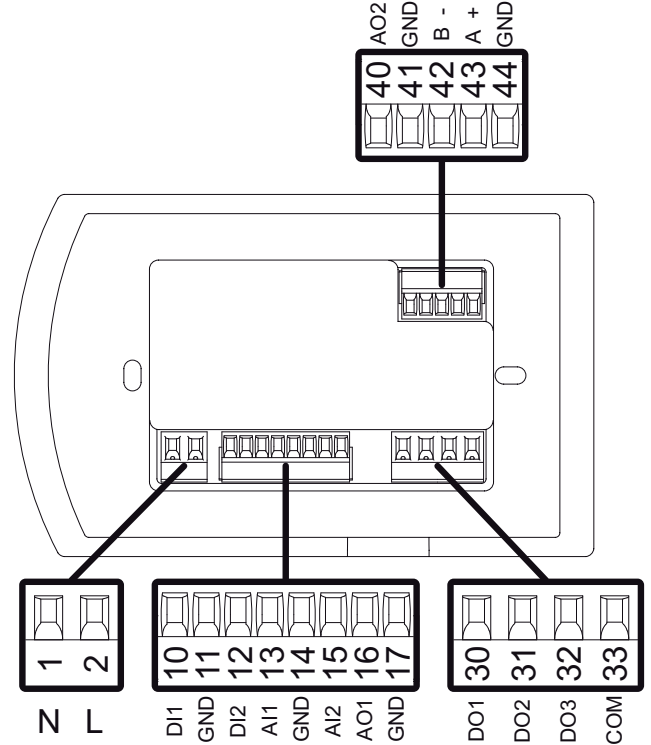

Connection of version TH-4xxSx1

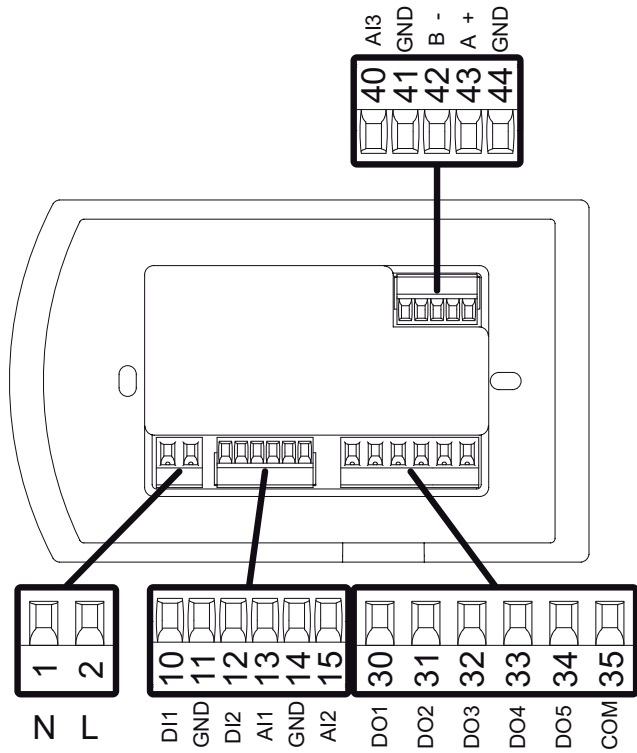

Terminal blocks:

N - L = 230 V AC power

DI1 - DI2 = Digital inputs 1 and 2

AI1 - AI2 - AI3 = Analogue inputs 1...3

AO1 - AO2 - AO3 = Analogue outputs 1...3

DO1 - DO2 - DO3 - DO4 - DO5 = Digital outputs 1...5

COM = Common for digital outputs

A + / B - = Modbus (only versions **TH-xMxSx1**) or BACnet (only versions **TH-xBxSx1**)

GND = Common for digital inputs, analogue inputs, analogue outputs and modbus

40. Dimensions

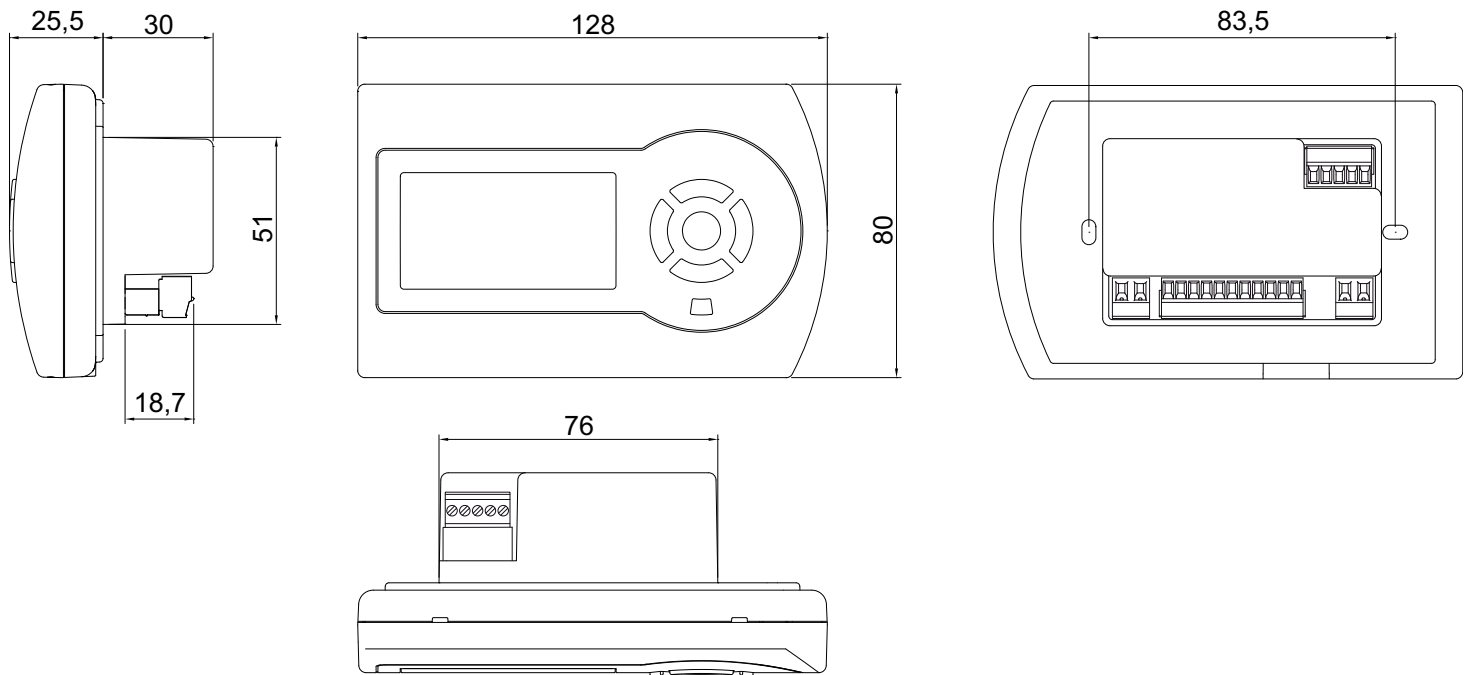

41. Installation instructions

Install the appliance in a location away from sources of heat and away from direct airflow, at around 1.5m above the floor. Do not install the thermostat on particularly cold or hot walls or on walls directly exposed to outside.

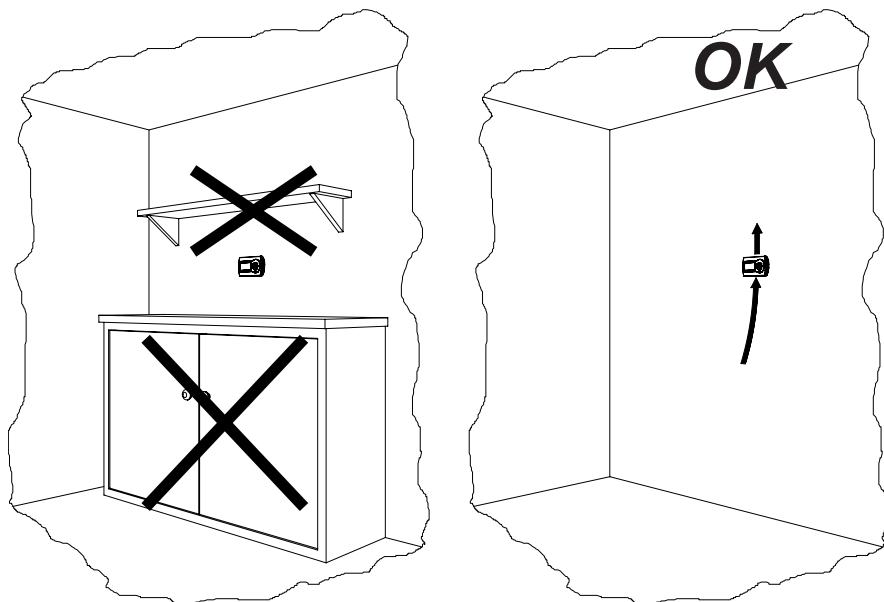
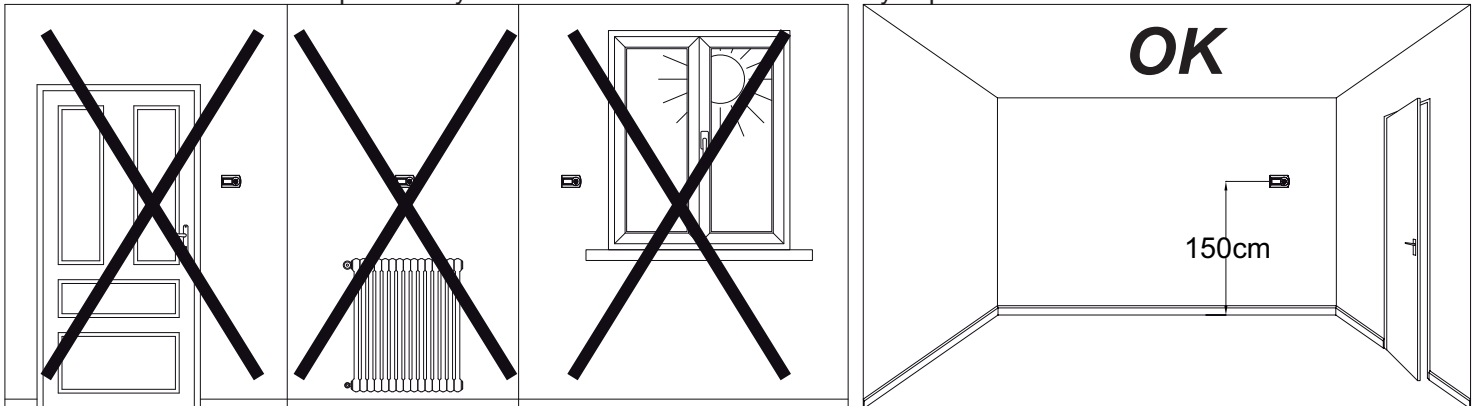

Installation with 3 module flush mounting housing.
E.g.: Bticino 503E (available on request).
Mounting hole centre distance 83.5mm.

1

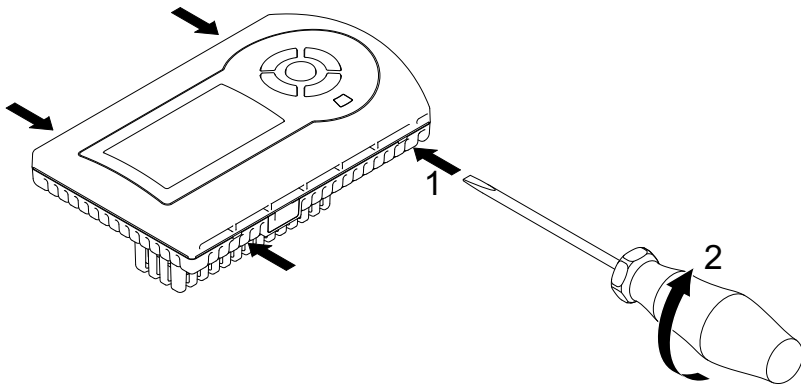

2

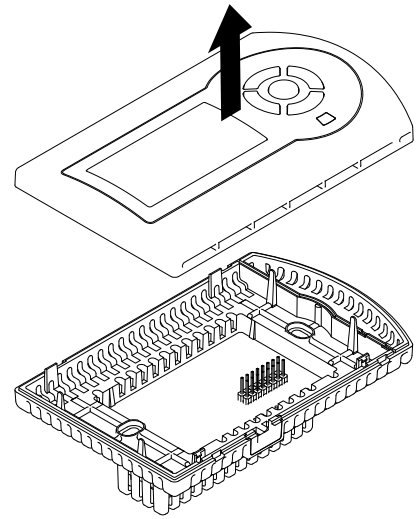

3

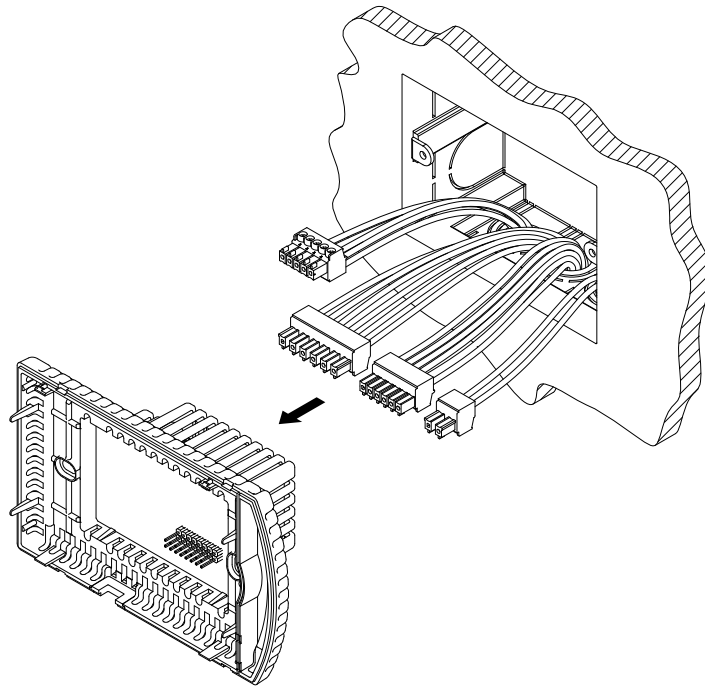

4

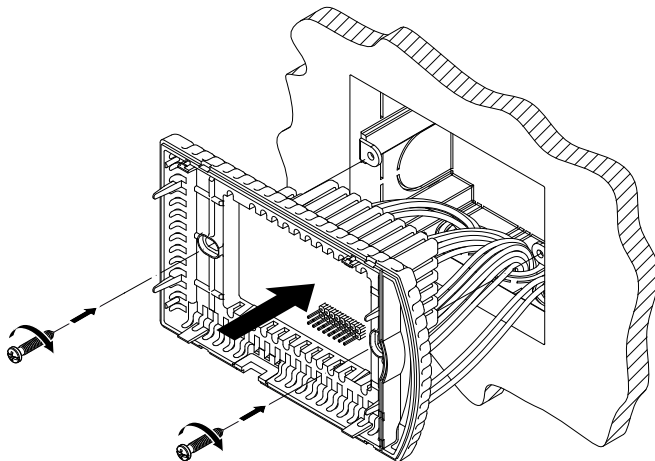

5

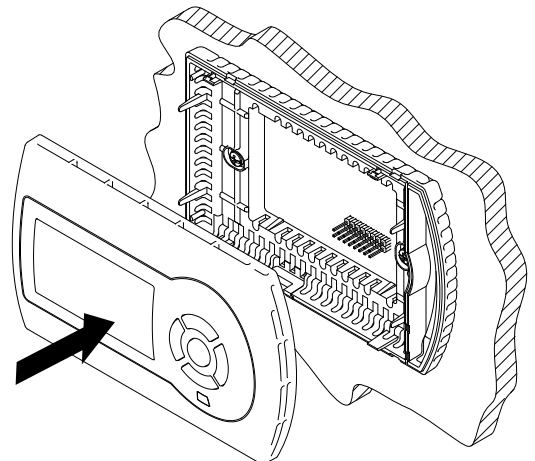



industrie
technik®

