

CRNOTERMOSTATO DIGITALE DA PARETE
WALL MOUNTING DIGITAL CHRONOTHERMOSTAT
CHRONOTHERMOSTAT DIGITAL POUR MONTAGE EN SAILLIE
DIGITAL RAUMTHERMOSTATUHR WANDMONTAGE
CRNOTERMOSTATO DIGITAL DE SUPERFICIE



PE - DECRNN032 10/10 (mask-2)

Alimentazione a pile
Settimanale, Inverno / Estate
3 livelli di temperatura + antigelo
Ingresso per programmatore telefonico

Battery-powered
Weekly, Winter / Summer
3 temperature levels + antifreeze
Telephone programmer input

Alimentation par piles
Hebdomadaire, Hiver / Eté
3 niveaux de température + antigel
Entrée par télécommande téléphonique

Batteriebetrieb
Wöchentlich, Winter / Sommer
3 Temperaturstufen + Frostschutz
mit Eingang für Telefonschaltung

Alimentación con pilas
Semanal, Invierno / Verano
3 niveles de temperatura + antihielo
Entrada para mando telefónico

INTRODUCTION

ENGLISH

The weekly-setting wall mounting chronothermostat suitable for heating and/or cooling systems, is equipped with a big, clear display (some models have the backlight function) so as to monitor all functions in real time.

Its principal feature is the ease with which it can be programmed, in fact, despite the number of functions it has, it is very simple to use. Various programmes are already set in its permanent memory, at 3 and 4 temperature levels, designed to provide maximum comfort. However, only a few seconds are needed to set the preferred temperatures to be applied throughout the day (even every 30 minutes!) and also for each day of the week. A standard function of the chronothermostat consists of the automatic adjustment of the temperature in the ON/OFF differential mode, so as to adjust itself to the thermal inertia of your particular system - the temperature can be set between 0.2°C and 2°C. Otherwise, you can choose the function in proportion with the cycles, which can be set to last 7-10-15-20 minutes, thus reducing the operating time of the boiler, which depends upon the difference between the set temperature and that of the room (the smaller the difference in temperature, the less time the boiler functions).

Moreover, the chronothermostat can automatically anticipate ignition (intelligent function), for the room to reach the desired temperature at a particular time. The set temperature scale is in degrees centigrade (Celsius) and you can calibrate the measurement of temperature by setting a correction value (from -1.9 to +1.9 °C). When switched to degrees Fahrenheit, all temperature settings are updated according to the new temperature scale.

Particular attention has been given to the energy saving factor: the Holiday function, the interruption function for domestic cleaning, the option to block the set temperatures, the anti-freeze temperature can be set between 4 and 12 °C, telephonic control (optional telephone programmer). These prevent energy from being wasted, which leads to economic savings (refer to the following pages for the description of these and other functions).

INDEX

1 - TECHNICAL SPECIFICATIONS	pag. 29	7 - PROGRAMMABLE FUNCTIONS FOR USE WITH DIFFERENT APPLIANCES	pag. 48
2 - GENERAL VIEW AND KEYS FUNCTIONS	pag. 30	8 - ACTIVATION VIA TELEPHONE PROGRAMMER	pag. 52
3 - DISPLAY LEGEND	pag. 31	9 - FIXED SET OFF THE PROGRAMS	pag. 128
4 - INSTALLATION	pag. 32		
5 - PROGRAMMING	pag. 36		
6 - ENERGY SAVING FUNCTIONS	pag. 43		

1 - TECHNICAL SPECIFICATIONS

Supply voltage:	N° 2 alkaline 1,5 V type AA (LR6)
Working:	2 years
Time remaining from when "Battery Low" symbol:	1 month approx.
Backlight display:	Only for models with this option
Type of action, disconnect and device:	1/ B / U / Electronic
Type of output:	Relay with single-pole changeover contact, voltage free, NO / COM / NC - max 8(2)A/250 V ac
Software:	Class A
Nominal pulse voltage:	4 kV
Wire section to relay terminals:	0,75 mm ² ÷ 2,5 mm ²
Input (telephone programmer):	for NO contact, zero potential
Wire section to telephone programmer input terminals:	0,5 mm ² ÷ 1,5 mm ²
Insulation:	Class II <input type="checkbox"/>
Protection degree:	IP 30
Pollution rating:	Normal
Ambient temperature display range:	- 5 °C ÷ +39 °C
Ambient temperature indicator resolution:	0,1 °C
Adjustment temperature range (t1/t2/t3):	+ 5 °C ÷ +39 °C
Setting temperature resolution:	0,1 °C
Temperature correction (Offset):	Settable from -1,9 °C to +1,9 °C
Frost protection temperature (t _✱):	Settable from +4 °C to +12 °C (default 5 °C)
Methods to adjust the temperature:	
- DIFFERENTIAL (default)	Settable from 0,2 °C to 2 °C (default 0,6 °C)
- PROPORTIONAL	Cycle settings are 7-10-15-20 minutes (default 10')
Thermal gradient:	max 1°K / 15 min
Operating temperature limits:	- 5 °C ÷ +50 °C
Storing temperature limits:	-10 °C ÷ + 65 °C
Reference standard for CE mark:	LVD / EMC EN60730-2-7 EN60730-2-9

Note: when room temperature flashes, display scale (-5°C or +39°C) has been exceeded.

Err indicates that heat control activity has been suspended due to probe error.



2 - GENERAL VIEW AND KEY FUNCTIONS

Note: more particular button functions are described in the specific paragraphs.

Combination giving Reset
(Press simultaneously for 2 sec.)

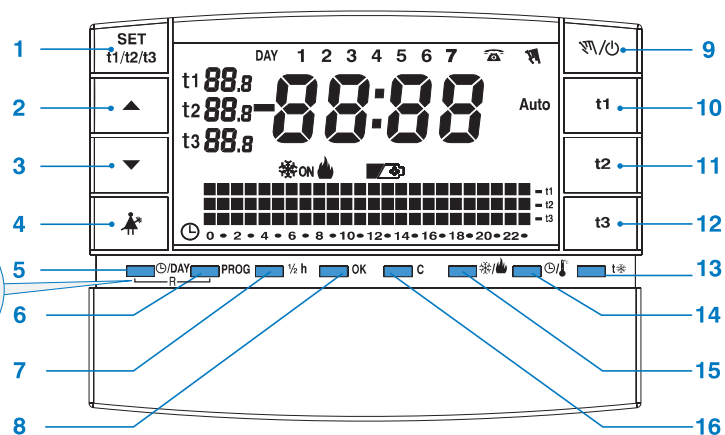



1. Select SET temperature: Comfort **t1**, Working **t2**, Economy **t3**; adjustable from +5 °C to +39 °C
2. Increase temperature ▲
3. Decrease temperature ▼
4. Suspend program during room cleaning
5. Changes the current hour - minutes - day and displays the time or temperature
6. Select - display programs P 01 ÷ P 06
7. Half-hour program (½ h)
8. Operation confirm button
9. Select manual mode and deactivate chronothermostat (OFF)
10. Set temperature **t1** Comfort
11. Set temperature **t2** Working (pre-comfort) and activates/disables the intelligent function
12. Set temperature **t3** Economy (energy saving)
13. Set temperature **t*** Antifreeze
14. Time or temperature display
15. Winter  (heating) or summer  (cooling) operation
16. View total hours operation

3 - DISPLAY LEGEND

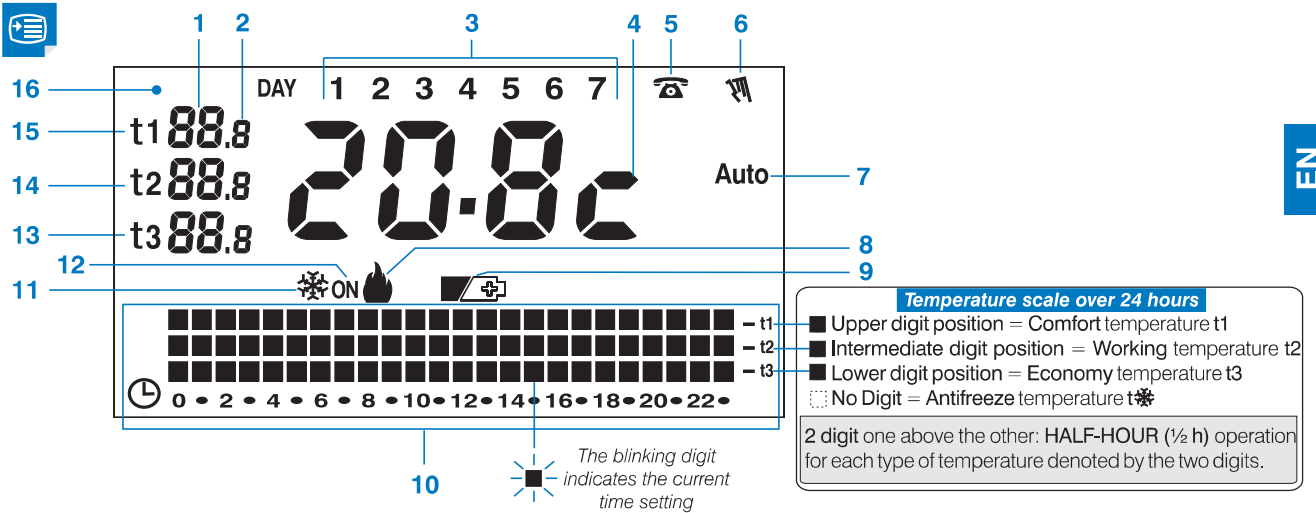

1. Reference temperature set
2. Displays tenths of a degree
3. Days of the week
4. Current time or temperature
5. Telephone programmer operating mode indicator
6. Override manual mode indicator
7. Smart operation (Auto)
8. Heating program active indicator
9. Battery low (replace the batteries within 30 days)

10. Temperature scale over 24 hours
11. Cooling programme enabled
12. Appliance in operation (blinking ON)
13. **Economy t3** Temperature Setting (energy saving)
14. **Working t2** Temperature Setting (pre-comfort)
15. **Comfort t1** Temperature Setting
16. Backlight Display (only for models with this option)
The backlight function is activated by pressing any key and goes off 6 seconds after the last key is released

4 - INSTALLATION

4.1) DIMENSIONS

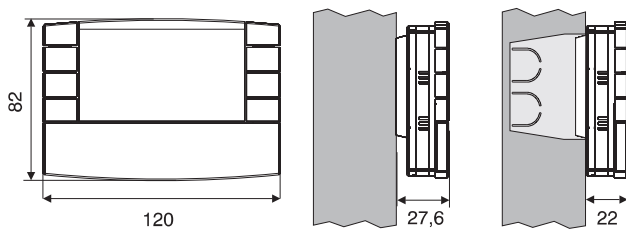

4.2) INSTALLATION GUIDELINES

Installation of device: independent - fixed

- wall mounting - on the back round box - on rectangular flush mounting box (3 modules)
- Install the chronothermostat at a height of 1,5 m from the floor, far from heat sources, windows and anything that might modify de standard operational mode.

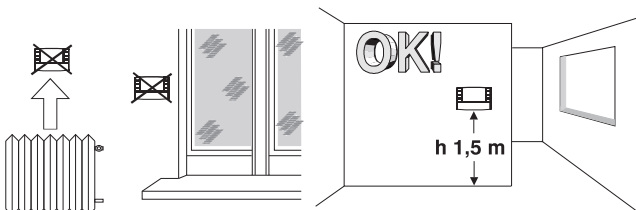

4.3) FIXING BASE

- Switch off mains power to device
- Using screws, fixing the base to the wall at to the back round or rectangular box using holes **A** provided.
- If the chronothermostat base is to be mounted on a metal wall, apply two special insulating washers to the two screws.

A - fixing holes

B - pass wires from back round or rectangular box

C - fixing clips of chronothermostat

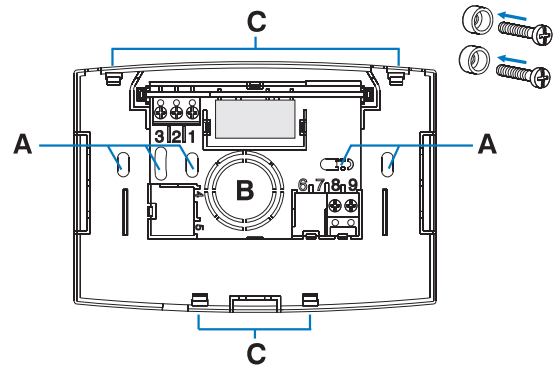

To ensure the chronothermostat is fitted correctly to the wall mounted base, care must be taken to ensure that the base is not distorted by screwing the rectangular back box too tightly to the wall.

4 - INSTALLATION

4.4) ELECTRICAL CONNECTIONS

Important: installation and electrical connections of devices and appliances must be carried out by skilled people and in compliance with current regulations. The manufacturer declines any liability in connection with the use of products subject to special environmental and/or installation standards.

- turn off the electrical power to the wiring.
- connect the controlled device to the terminals:
 - 1 - common
 - 2 - normally closed contact
 - 3 - normally open contact
- The telephone programmer can be connected to terminals 8 and 9 to activate the chronothermostat from a distance.

Examples of electrical connections

N.B.: with heavy inductive loads (pumps and solenoid valves) it is recommended to connect an RC filter in parallel to the load

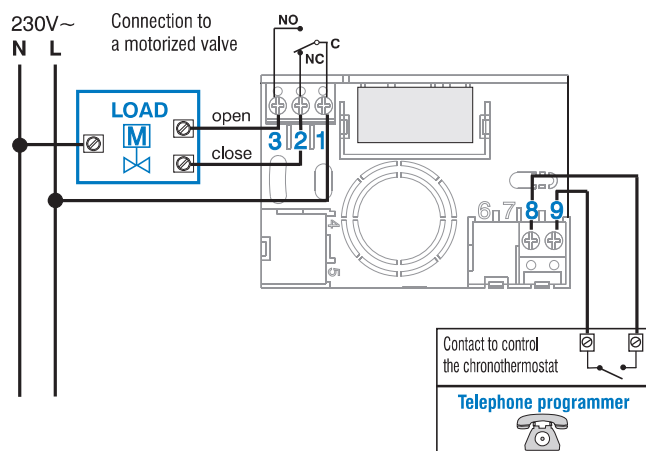
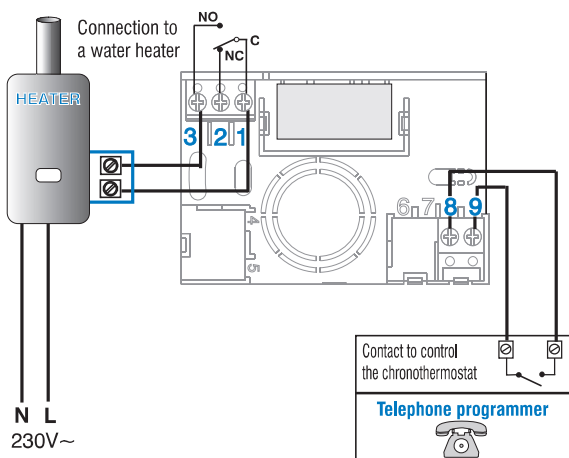

4 - INSTALLATION

4.5) ATTACHING OR REMOVING THE CRONOTHERMOSTAT FROM ITS BASE

- 1°** Attach the cable cover by inserting panel **D** into special slot **E** in the base, then fasten it to the catches **F** by pressing lightly. To remove the cover, use a small screwdriver to prize apart each catch **F** in turn.

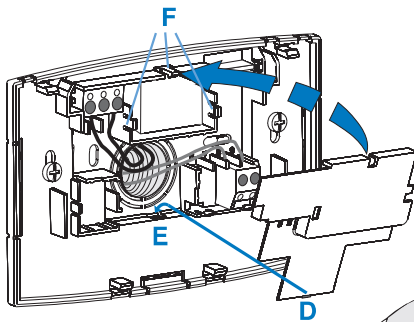

3°

In order to remove the chronothermostat from its wall-mounted base, grip as shown in the diagram, then pull outwards from the left-hand side.

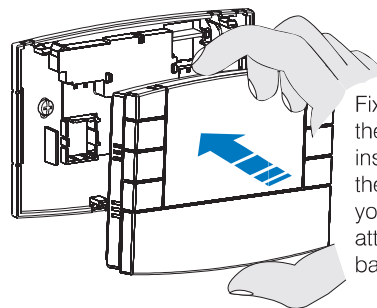
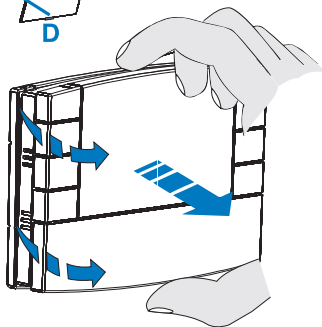

2° Fix the chronothermostat on the base, taking care to insert the contacts correctly, then exert light pressure until you hear the click of the attachment hooks on the base.

Easy Programming



All the settings can be carried out before securing the chronothermostat to the base on the wall; this allows you to do the programming while being comfortably seated.



Caution !

If the chronothermostat is programmed before it is fixed to the wall-mounted base, it may happen that after installation the **ON** indication (off or blinking) in the display does not correspond to the actual status of the relay. Within **1 minute (max)** of the chronothermostat being fixed to the base, the relay will be activated according to the **ON** (off or blinking) indication displayed.

4 - INSTALLATION

4.6) INSERTING OR REPLACING BATTERIES

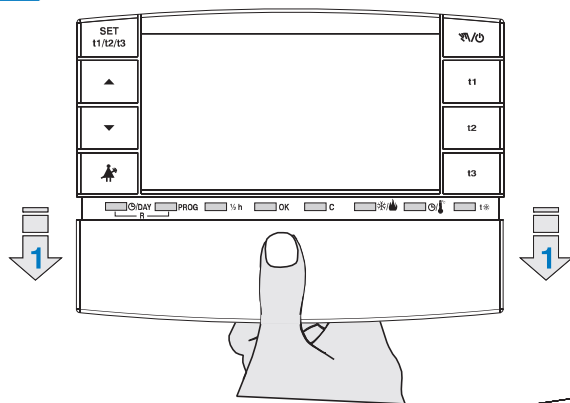

Dispose of the exhausted batteries by throwing them into the special containers, being careful to comply with environmental protection standards.

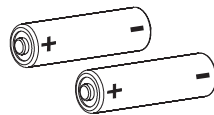

Insert or replace with two 1,5V batteries type AA - LR6 taking care to position the poles correctly
USE ONLY HIGH-QUALITY ALKALINE BATTERIES
(Duracell and Energizer are recommended)

Note: when changing batteries, the time available to perform the operation is about 1 MIN.

Slide the cover as shown in the figure opposite to reveal the first row of keys (programming keys); then slide again to reveal the battery compartment.

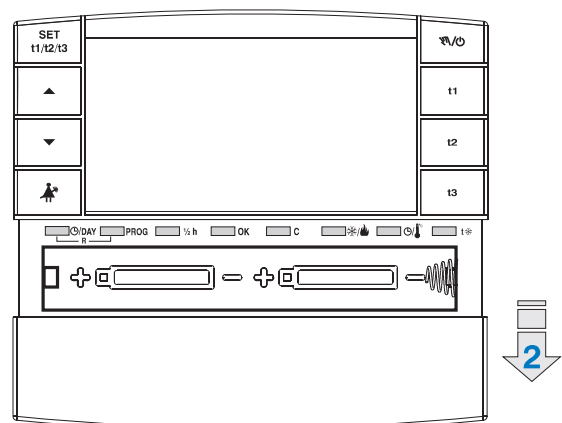

5 - PROGRAMMING THE CHRONOTHERMOSTAT

All settings must be confirmed by pressing OK, otherwise the chronothermostat returns to the previous settings after 2 minutes and the changes will not be saved.

Upon inserting the batteries or following a general reset, (Reset paragraph 5.10, keeping the **DAY** and **PROG** buttons pressed for 2 sec.): all sections that are on will appear on the display, after which, the blinking digits relative to the hour and minutes will appear, as shown in the figure opposite.

IMPORTANT: For the chronothermostat to work you must set the following: current hour, minutes, day and weekly program.

5.1/A) SETTING THE CURRENT TIME: HOUR - MINUTES

Use the **▲▼** keys to set the current time; pressing the key repeatedly increases and decreases the time by one minute and keeping the key pressed activates the rapid scroll. Press **OK** to confirm once the time is set (fig.1).

5.1/B) SETTING THE CURRENT DAY OF THE WEEK

After having set the time, the first day of the week (**1**: Monday) will blink on the display; select the current day by using the **▲▼** keys (e.g. 3 = Wednesday) and press **OK** to confirm (example fig.2).

P01 will blink in the display.

5.1/C) SELECTING THE PROGRAM

The chronothermostat has 4 fixed programs (see chapter 9 - pag. 128/129).

If one of these programs (P01 ÷ P04) is suitable, press **PROG** repeatedly until the display shows the particular program, then press **OK** (example fig.3). The following will appear on the display: the number of the current day, the room temperature and the 24-hour temperature scale as set in the current blinking hour digit; the chronothermostat is running.

If none of these programs happens to be suitable, press **PROG** repeatedly until program **P05** appears, then proceed as indicated in heading 5.2.

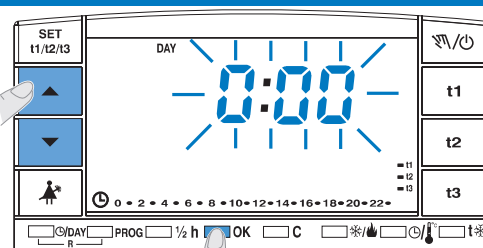

fig. 1

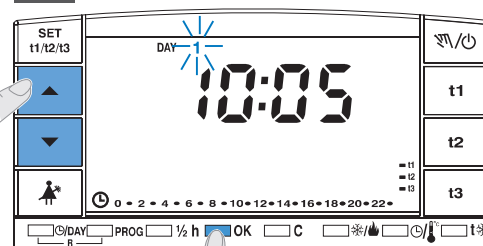

fig. 2

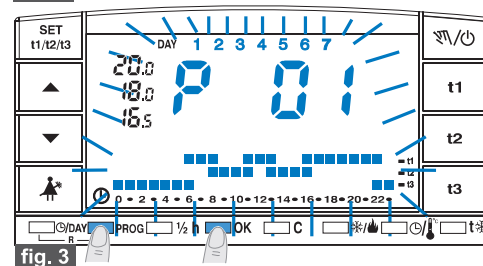

fig. 3

5 - PROGRAMMING THE CHRONOTHERMOSTAT

P05 FREE 5.2 - FREE PROGRAM P 05

Program **P 05** can be programmed freely for every hour of the day on four different temperatures (**t1**, **t2**, **t3**, **t***) and differently for every day of the week. Press **PROG** until **P 05** appears in the display.

Confirm the selection of program **P 05** by pressing **OK** (fig.4).

The display will show the three digits relative to the time 0:00, with the day indicator **1** positioned on **Monday**, all blinking. To select the temperatures for the time currently blinking, press the relative button. (**t1**, **t2**, **t3**, **t***) fig.5.

N.B.: press **PROG** to exit from P 05 without saving.

Setting the temperatures for Monday.

For each hour of the day, confirm the desired temperature (Comfort, Working, Economy, Antifreeze) by pressing **t1**, **t2**, **t3**, **t*** (the time is confirmed every time the key is pressed and the hour moves forward by one hour; the corresponding time is shown on the display) until the 24-hour curve for **Monday** is complete (ex. fig.6).

Note: the buttons **t1**, **t2**, **t3**, **t*** can be pressed momentarily (1h forward at each touch) or pressed and held until the desired hour is reached (moving forward automatically 1h with each blink).

Note: pressing the button **t*** (Antifreeze) the digit not denoted on the 24-hour temperature scale.

It is also possible to program half-hours (½ h), as indicated in heading 5.3.

Should you make a mistake whilst setting the temperatures for Monday (the **▲▼** keys can be used to rapidly move to the time that is to be reset on the temperature scale: the corresponding time is shown on the display) or press **OK** to confirm the setting.

When **OK** is pressed to confirm, the program set for Monday is saved in the memory, the dash will blink under Tuesday (2) and the digits relative to the time 0:00 will blink over the temperature scale for the previous day (fig.7 on the following page).

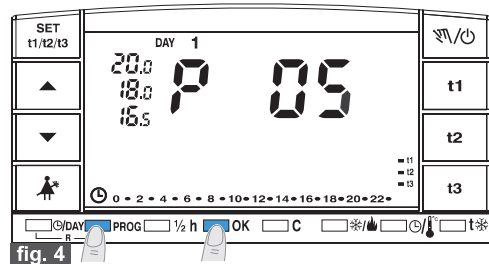

fig. 4

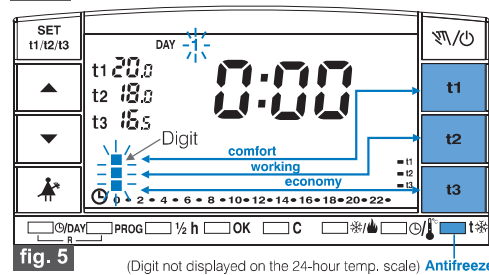

fig. 5

(Digit not displayed on the 24-hour temp. scale) Antifreeze

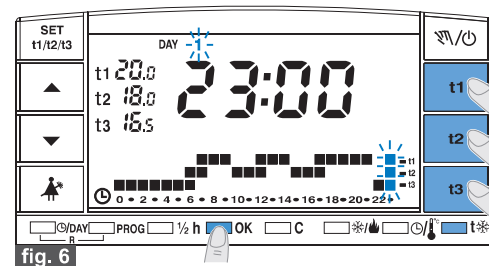

fig. 6

5 - PROGRAMMING THE CHRONOTHERMOSTAT

Setting the temperatures for Tuesday.

To use the same temperature scale as for Monday, press **OK**: the same scale will be entered for **Tuesday**; at this point the dash will blink under **Wednesday (3)** and the three digits will reappear blinking on the time 0:00.

If the same temperature scale is **NOT** required, proceed by pressing t1, t2, t3, t* as described for Monday.

Note: the ▲▼ keys can be used to rapidly move to the time that is to be reset on the temperature scale; the corresponding time is shown on the display.

Having set the temperatures for Tuesday, press **OK** to confirm.

You must complete the daily profile for each day of the week, otherwise the program setting cannot be saved.

Once the temperature scale is entered for **Sunday (7)**, press **OK** (example fig. 8) to save and return to the Monday (1) setting, **then press OK again for 4 seconds** (fig. 9); this operation **saves the complete weekly program**.

The display will show: the number of the current day, the room temperature and the temperature scale over 24 hours, programmed with the current hour digit blinking: **the chronothermostat is now in operation**.

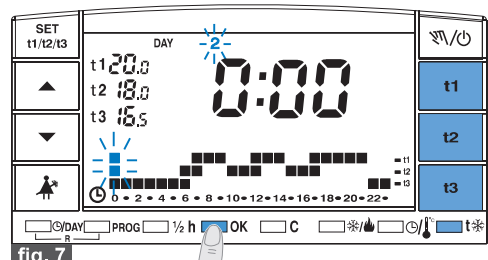

fig. 7

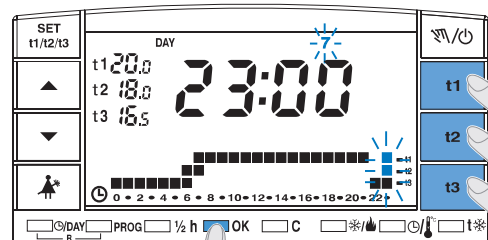

fig. 8

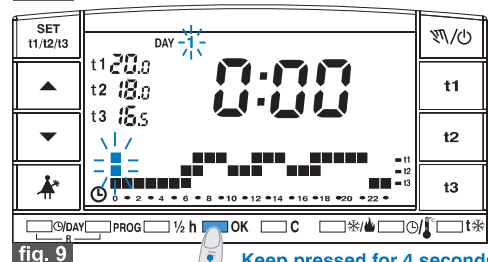

fig. 9

Keep pressed for 4 seconds

5 - PROGRAMMING THE CHRONOTHERMOSTAT



5.3 - PROGRAMMING HALF-HOUR (½ h)

For example, P05 setting, to program:

from h 06:00 to h 06:30 with temperature **t3** (economy)
from h 06:30 to h 07:00 with temperature **t1** (comfort)

- 1° Set temperature **t3** for h 06:00: press **t3** until the three blinking digits are set an hour later (h 07:00).
- 2° Press the button $\frac{1}{2}$ h to return to the previous hour (h 6,30), the two digits for **t1**, **t2** start blinking
- 3° Press **t1** to set the **t1** temperature for the second half hour, for h 06:00 the two **t1** and **t3** digits remain permanently alight, whilst the digits for the next hour (h 07:00) will blink.

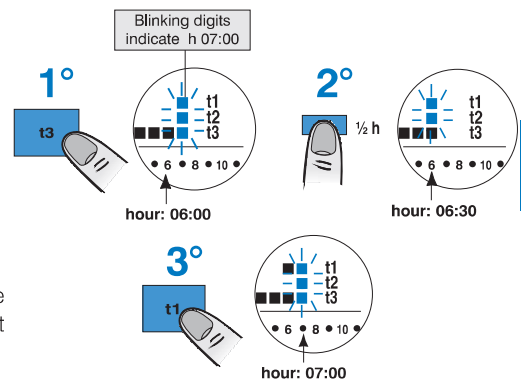

5.4 - EDITING THE SET P05 PROGRAM (previously saved)

Press **PROG** then **OK** to access the programming page in order to edit the settings previously saved for the **P05** program (fig. 10). If the day that must be changed is not Monday, press **OK** until the desired day is reached.

Use **t1**, **t2**, **t3** and **t*** to edit the daily profile, as described in heading 5.2.

Use the ▲▼ keys to move to the desired hour, which will be displayed. When the time is h 23:00 and the ▲ key is pressed, the time moves forward to 0:00.

Press **OK** to save the daily profile, then move on to another day's profile or **keep the OK key pressed for 4 seconds** to save the new weekly program.

Editing the profile of one day will not effect the following days and will be saved for the day in question.

N.B.: press **PROG** to exit from P 05 without saving.

fig. 10

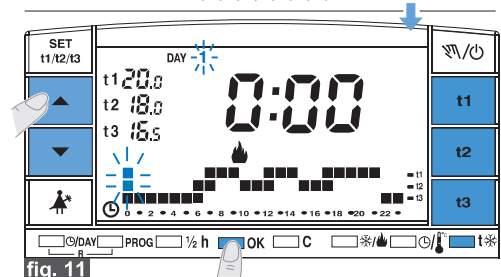

fig. 11

5 - PROGRAMMING THE CHRONOTHERMOSTAT

5.5 - PROGRAMMING SUMMER - WINTER



The chronothermostat is factory-set for “winter” operation, displayed as: (heating) fig.12. Under these conditions the appliance (burner) will be activated as described in the example:

Temperature set points:

t1 - Comfort = 20,0 °C

t2 - Working = 18,0 °C

t3 - Economy = 16,5 °C

t* - Antifreeze = 5 °C (can be set between 4 and 12 °C)

Burner operation with room temperature:

lower than 20,0 °C

lower than 18,0 °C

lower than 16,5 °C

lower than 5,0 °C (or at a set t*)



If the controlled appliance is an air conditioner: press the button for “Summer” operation, displayed as: (fig.13). In these conditions the appliance (air conditioner) will be activated as described in the example:

Temperature set points:

t1 - Comfort = 20,0 °C

t2 - Working = 22,0 °C

t3 - Economy = 23,5 °C

Air conditioner operation with room temperature:

higher than 20,0 °C

higher than 22,0 °C

higher than 23,5 °C

In either case, functionality of the device is confirmed when **ON** blinks.

N.B. If the anti-freeze temperature is set within the 24-hour thermal scale (digit not visible), the chronothermostat will not turn the air conditioner on at the set time.

Note: in either case, the SET temperature can be changed at any point in time, according to your needs (see paragraph 5.7).

5.6 - CHANGING HOUR, MINUTES, DAY OF THE WEEK

(E.g. Standard Time / Daylight Saving Time)

Keep pressed until the hour and minutes blink on the display (fig. 14).

- (If necessary) use the keys to change the hour and minutes.
- In any case press **OK** to confirm: the hour and minutes will not blink whereas the day of the week will.
- Select the day of the week (if necessary) with the keys.
- In any case press **OK** to confirm.

40 The chronothermostat returns to the program currently active.

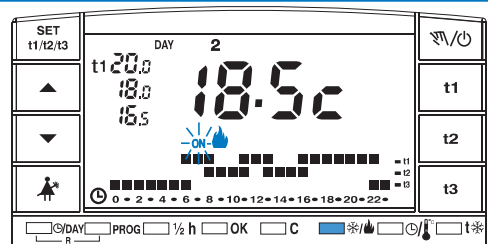

fig. 12

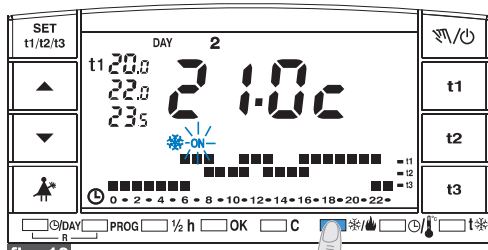
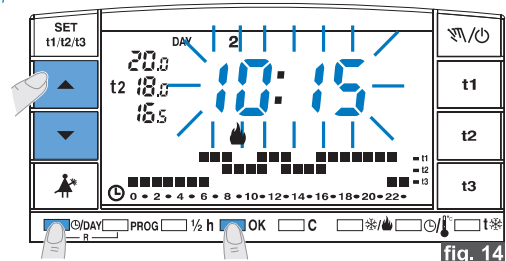

fig. 13



Keep pressed for 4 seconds

fig. 14

5 - PROGRAMMING THE CHRONOTHERMOSTAT

5.7 - CHANGING COMFORT, WORKING AND ECONOMY TEMPERATURES

If the factory set temperatures:

t1 = 20,0 °C, **t2** = 18,0 °C, **t3** = 16,5 °C (winter)

t1 = 20,0 °C, **t2** = 22,0 °C, **t3** = 23,5 °C (summer)

do not happen to be suitable, they can be changed according to preference from +5 °C to +39 °C, by pressing the relative buttons (fig. 15).

- Use $\text{SET}_{t1/t2/t3}$ (press repeatedly) to select the temperature set point that needs changing, indicated by the **t1** or **t2** or **t3** blinking symbol.
- Set the current set point by pressing buttons: \blacktriangle \blacktriangledown momentarily. At each touch the value changes by 0,1 °C.

The new temperatures selected in this way will be the new set points (for all programs).

Approximately 8 seconds after the last key press, the screen will revert to displaying the thermostat's regular functions: the temperature SET indicator for the current time (**t1** or **t2** or **t3**) will be displayed.

5.8 - SMART OPERATION (Auto)

In "smart" mode, the chronothermostat **anticipates** automatic activation of the connected device, so that the desired temperature is already reached at the set time, by a period of time which is automatically adjusted according to the characteristics of the system. Maximum early switch-on: 2 hours. **Auto** and **ON** (device enabled) will appear and blink on the display when activation is anticipated.

To activate "smart operation" press and hold **t2** for at least 4 seconds.

Operation is indicated by: **Auto**.

Keep **t2** pressed for 4 seconds to disable the function; the indicator **Auto** disappears.

This function can be enabled in "Winter" mode as well as in "Summer" mode.

Note: the setting will not be effected by a reset.

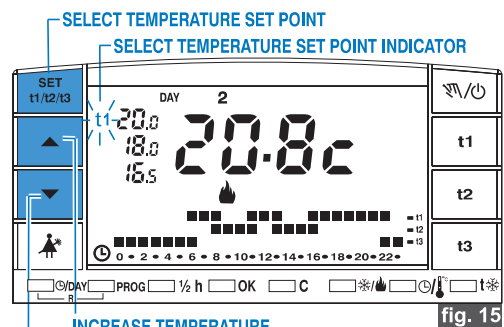

fig. 15

Important: the chronothermostat will accept temperature values that satisfy the following conditions:

Winter: t1 greater than or equal to t2 greater than or equal to t3

Summer: t3 greater than or equal to t2 greater than or equal to t1

Example: Winter mode (heating)

- the chronothermostat is set to go on at h 8:00

- the comfort temperature is set at 20 °C

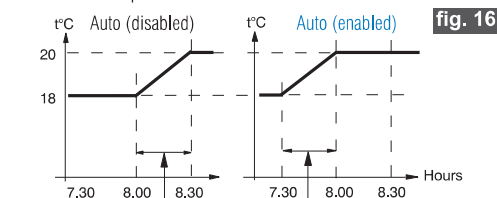

fig. 16

Necessary time to Reach the set Temperature

The necessary time to reach the set temperature is automatically anticipated

5 - PROGRAMMING THE CHRONOTHERMOSTAT

5.9 - READ PROGRAMS

Press **PROG**: the display will show the program in use. If the program is one of the four fixed programs (**P01 ÷ P04**), the display will automatically show the settings by groups of days (ex. fig.17-18).

Having read the program, press **OK** (fig. 18) to return to it (if no confirmation is given, after 2 minutes the chronothermostat will revert to the program set initially).

If the program in use is **P05**, the settings for each day will scroll automatically; after 2 minutes, program **P05** will be re-set automatically, otherwise keep **OK** pressed for at least 4 seconds.

Note: in read mode, programs are selected sequentially by pressing PROG.

With Read Programs activated, it is possible to replace the current program and/or change program **P05**.

- **When you wish to change the current program**, press **PROG** to select the new program (**P01 ÷ P04**) and confirm by pressing **OK**. If you wish to select **P05** as the new program, press **OK** and follow its program settings as explained in paragraph 5.2. If the **P05** program has been previously set, keep **OK** pressed for at least 4 seconds to confirm the program.

- Follow the instructions explained in paragraph 5.4 to edit program **P05**.

5.10 - RESET

To clear unwanted data that may have been entered (e.g. after a programming test) press: **DAY** and **PROG** simultaneously (approximately 2 seconds).

All segments of the display light up (general self-test).

Afterwards, the display will appear as in figure in chapter 5.1/A and the chronothermostat is ready to be programmed again.

Warning: the Reset does not affect the following functions, which remain in the memory: fixed temperature set points - pump activation 2 min/day (anti-scale cycle) - antifreeze temperature deselected or changed - smart operation (Auto) - differential setting and its relative value or proportional setting and its relative cycle - temperature correction (OFFSET) - temperature setting: °C or °F and number of seasonal hours of operation.

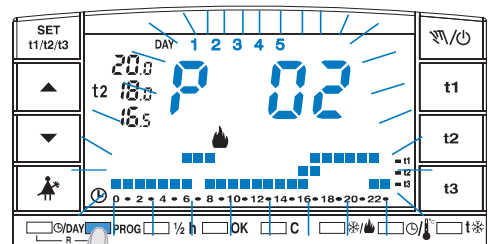

fig. 17

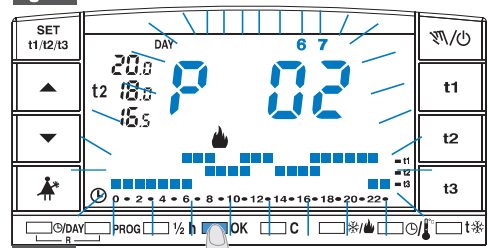

fig. 18

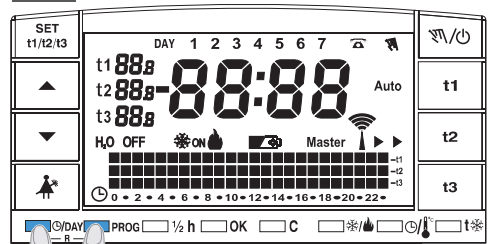

fig. 19

RESET (Press simultaneously for 2 sec.)

6 - ENERGY SAVING FUNCTIONS

6.1 - LIMITING SETTABLE TEMPERATURE VALUES

In some cases, when the chronothermostat is installed, for instance, in public offices, hotels, etc., it may be useful to limit the maximum and minimum temperature settings to avoid incorrect settings being entered by unauthorised personnel.

The maximum (t1 comfort) and/or minimum (t3 economy), temperature settable with the chronothermostat, or both, can be limited. This limitation can be applied to both winter and summer operations.

The relative settings are stored and will not be deleted by a reset.

The operation can be executed only with the program activated (P01 ÷ P05).

The figures at the side indicate: Winter mode; maximum temperature setting (t1) = 20°C, minimum temperature setting (t3) = 16.5°C;

Setting a limit for the maximum temperature t1

Press $\text{SET}_{t1/t2/t3}$ one or more times to select the t1 setting (t1 will blink) fig.20. Set the desired temperature with the \blacktriangle \blacktriangledown keys. Press t1 and OK simultaneously within 8 seconds; t1 and the set value will blink (fig.21). After a few seconds, the chronothermostat will return to the previously set program.

Setting a limit for the minimum temperature t3

Press $\text{SET}_{t1/t2/t3}$ one or more times to select the t3 setting. Set the desired temperature with the \blacktriangle \blacktriangledown keys. Press t3 and OK simultaneously within 8 seconds; t3 and the set value will blink (fig.22). After a few seconds, the chronothermostat will return to the previously set program.

Unblocking the temperature limits

Press $\text{SET}_{t1/t2/t3}$ to select the value that is to be unblocked (t1 or t3) and the symbol together with the value of the set temperature will blink.

Press the relative t key (t1 or t3) together with OK within 8 seconds; the unblocking process is confirmed when the digits showing the temperature stop blinking. After a few seconds, the chronothermostat will return to the previously set program.

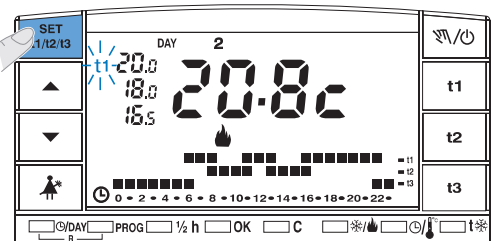

fig. 20

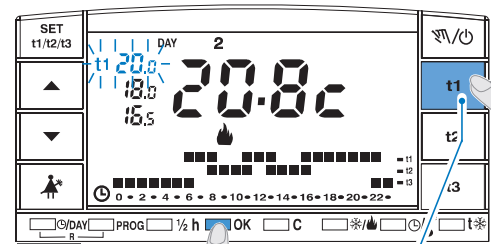

fig. 21

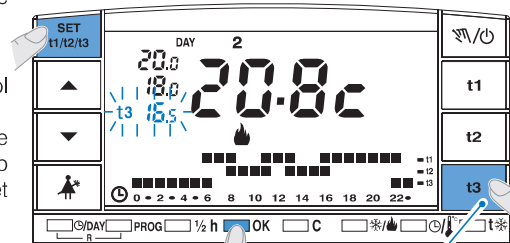

fig. 22

6 - ENERGY SAVING FUNCTIONS

6.2 - MANUAL OPERATION

There are 2 manual modes, both of which have the effect of suspending the current program:

A) Temporary manual operation

Briefly press M/C : the M symbol will blink on the display and the current temperature level will be applied to the remaining hours of the day (fig.23).

Set the desired temperature for when in manual mode by pressing **t1**, **t2**, **t3** or **t***; set the desired temperature by pressing the \blacktriangle / \blacktriangledown keys.

The temporary manual mode will automatically terminate at midnight of the current day.

A shorter time can be set as follows:

Press **OK** (fig.24) and the number of hours that the temporary manual mode will be active for will blink on the display. Set the desired duration with the \blacktriangle / \blacktriangledown keys, then press **OK** to confirm. Once the set number of hours passes, it will return to the set program.

To exit from the temporary manual mode and return to the set program, press M/C again: the thermal scale of the current day will show on the display, according to the program in operation before the temporary manual mode was activated.

B) Permanent manual operation

Press and hold the M/C button until the symbol M remains on the display permanently (4 seconds approx.); the current temperature level will be applied to all hours of the day (fig.25).

Select the temperature level desired by pressing **t1**, **t2**, **t3** or **t*** and set the desired temperature by pressing the \blacktriangle / \blacktriangledown keys.

Permanent manual operation remains active indefinitely; to deselect manual mode and return to automatic operation, (program) press M/C .

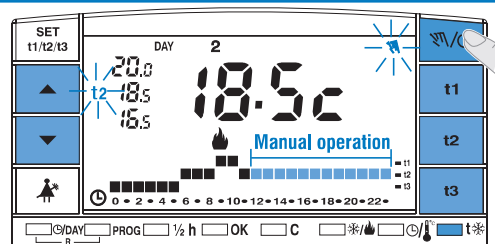

fig. 23

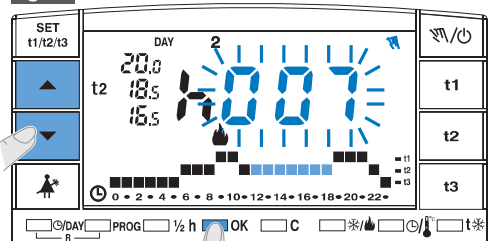

fig. 24

Keep pressed for 4 sec.

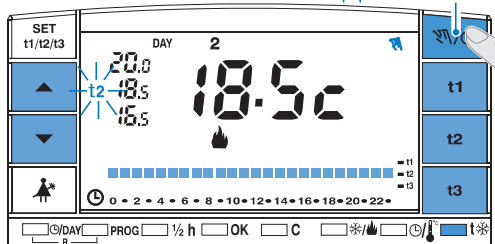

fig. 25

6 - ENERGY SAVING FUNCTIONS



6.3 - HOLIDAY PROGRAM - P 06

If you will be away from home for a few days select the **P 06** Holiday program.

- Repeatedly press **PROG** until **P 06** appears on the display, then press **OK** to confirm (fig.26).
- The following will appear on the display: the day of the week, the symbol **c**, the word **HOLIDAY** (fixed) and the digits **000** will blink.
- Calculate the number of hours you will be away for (example: **168** hours = 7 days). The maximum number of hours you can enter in **Holiday** mode are **999**.
- Set the duration of your absence with the **▲▼** keys - pressing repeatedly will increase or decrease by one hour, keeping either key pressed will activate the rapid scroll.
- Press **OK** to confirm (fig.27).

As from this moment the chronothermostat will begin a countdown and the **Holiday** program will maintain the set anti-freeze temperature (ranging from 4 to 12 °C) until the countdown reaches zero.

Once the countdown ends, the **Holiday** program will activate your usual program (P01 ÷ P05), in order for you to find your home at the desired temperature upon your return.

Note: you can exit the **HOLIDAY** program earlier anyway, by pressing **PROG** then pressing **OK**. Use the **▲▼** keys to reset the hours left for your return to **c000**, then press **OK** to confirm and return to your usual program.

Warning: if the antifreeze temperature is deselected permanently (see heading 7.5) or in "summer" operation, the **Holiday** program will keep the controlled appliance disabled for the full programmed duration.

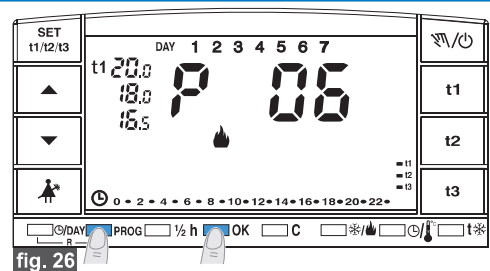

fig. 26

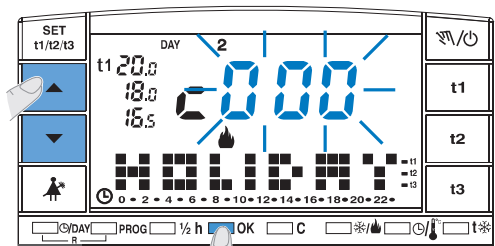

fig. 27

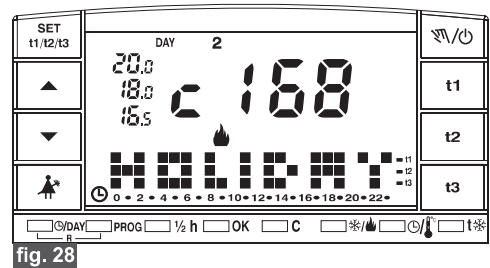

fig. 28

6 - ENERGY SAVING FUNCTIONS

6.4 - DISPLAYING CONSUMPTION CALCULATED CHECKING THE HOURS OF OPERATION OF THE APPLIANCE

The chronothermostat calculates and memorizes the hours of operation of the burner (and/or air conditioner) both during the 24 hours of the previous day and from the start of the season (total hours operation). This information is useful in monitoring (for indicative purposes) the energy consumption of the system. Total consumption for the system in litres (fuel oil) or cubic metres (natural gas) can be computed simply by multiplying the hourly consumption value (indicated on the data plates of the burner) by the hours operation.

- **To display the operating time during the last 24 hours:**

Briefly press **C** (fig.29) and the requested number of hours of operation will appear on the display.

- **To display the total hours operating from the beginning of the season:**

press and hold **C** for at least 4 seconds (fig.30), and the total hours operation will appear.

- **To reset the total hours operation from the beginning of the season:**

press and hold **C** for at least 8 seconds (until the temperature scale setting ends within 24 hours), then press **OK** simultaneously; **0000** will appear on the display for a few seconds (total hours device operation counter reset), release **C** and **OK**.

Following the reset, the chronothermostat begins a new count of the total hours operation.

6.5 - EXCLUSION OF THE CHRONOTHERMOSTAT (OFF)

Press and hold button \mathcal{V}/\mathcal{O} until **OFF** appears in the display, to indicate that the chronothermostat is deactivated (fig.31).

In this condition all functions of the chronothermostat are inactive; only the current hours continues to be displayed.

Pressing button \mathcal{V}/\mathcal{O} again, the program set previously will resume.

Note: in this instance, the chronothermostat disables the anti-freeze function too.

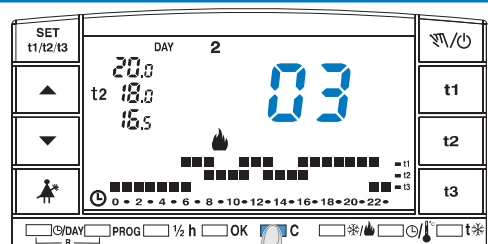

fig. 29

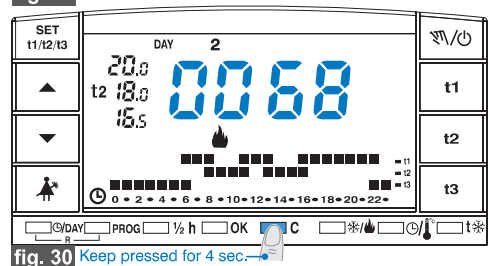

fig. 30

Keep pressed for 4 sec.

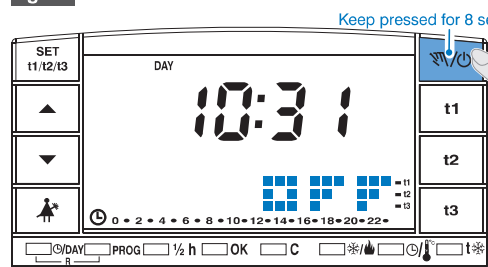



fig. 31

Keep pressed for 8 sec.

6 - ENERGY SAVING FUNCTIONS



6.6 - SUSPENSION OF PROGRAM FOR ROOM CLEANING

When operating with programs (**P01 ÷ P05**), the controlled appliance can be deactivated for 3 hours, by pressing button , during which time the chronothermostat will switch to antifreeze mode (fig.32).

The activation of this function is shown by the absence of the digits denoting the 3 hours, starting from the current hour. Once the 3 hours have elapsed, the chronothermostat will revert to the program interrupted.

To reactivate the program interrupted before the end of the 3 hours, press button  the missing digits will reappear.

Warning: if the antifreeze temperature is deselected permanently (see heading 7.5), or in "summer" operation, the controlled appliance will keep disabled for three hours.

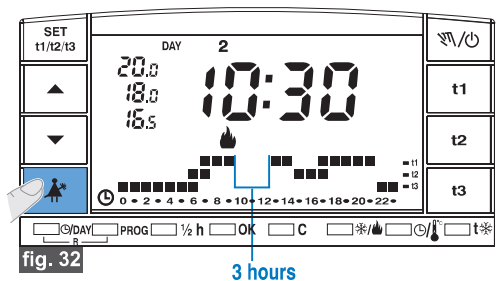

6.7 - INDICATION OF SYSTEM TROUBLE

In Winter  :

if, during normal operation (**ON** blinking), the chronothermostat does not sense a significant rise in temperature within 2 hours, the display will indicate that the heating system is not working **hOFF** (fig.33).

In Summer  :

if, during normal operation (**ON** blinking), the chronothermostat does not sense a significant rise in temperature within 2 hours, the display will indicate that the heating system is not working **cOFF** (fig.34).

The indication will disappear automatically as soon as a significant rise (winter) or drop (summer) in temperature has registered.

Note: in both cases, the relay remains ON (device is enabled)

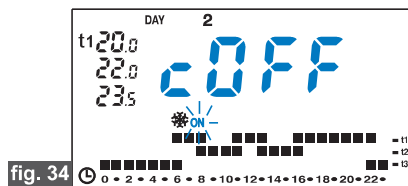
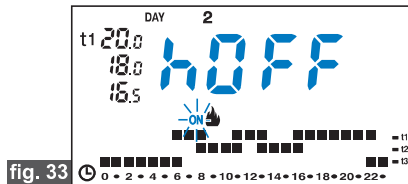

7 - PROGRAMMABLE FUNCTIONS FOR USE WITH DIFFERENT APPLIANCES



7.1 - TEMPERATURE DIFFERENTIAL (ON/OFF)

The chronothermostat operates (factory set) in differential mode (ON-OFF) with a differential value factory-set to 0,6 °C.

The differential value must be set according to the system's thermal inertia; a low value is recommended for systems with radiators (e.g. in cast iron) and a high value for systems with fan coils.

The differential value may be displayed and changed as follows:

- Ensure that the DIFFERENTIAL ON/OFF mode is selected as shown in paragraph 7.3.
- Press and hold **t1** until the existing differential value blinks on the display, e.g. **d0.6c**
- Change the value (from 0,2 °C to 2 °C) using the buttons ▲ or ▼ which give increments of 0,1 °C; press **OK 3 times** once the desired value is reached to return to the set program.

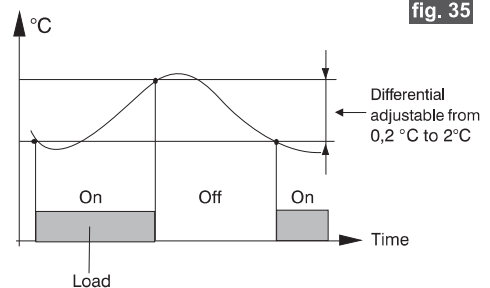

fig. 35

Note: the setting will not be effected by a reset.



7.2 - PROPORTIONAL OPERATION

As opposed to the differential, the temperature can be adjusted **proportionally** with adjustable cycles of 7, 10, 15 or 20 minutes. This system maintains the desired temperature more stable by increasing the user's sense of comfort and saving on energy consumption.

The duration of the cycle can be viewed and changed as follows:

- Ensure that the PROPORTIONAL mode is selected as shown in paragraph 7.3.
- Press **t1** until the cycle in progress blinks on the display e.g. **P 10** (factory set).
- Select the desired cycle by pressing ▲ or ▼ (**P 07** = 7 minutes; **P 10** = 10 minutes; **P 15** = 15 minutes; **P 20** = 20 minutes); press **OK 3 times** to return to the set program.

Note: the setting will not be effected by a reset.

Setting example t = 20 °C - Cycle = 10 min

t = 20.5 °C	Device is always off
t = 20.4 °C	Device is 1 min ON - 9 min OFF
t = 20.3 °C	Device is 2 min ON - 8 min OFF
t = 20.2 °C	Device is 3 min ON - 7 min OFF
t = 20.1 °C	Device is 4 min ON - 6 min OFF
t = 20.0 °C	Device is 5 min ON - 5 min OFF
t = 19.9 °C	Device is 6 min ON - 4 min OFF
t = 19.8 °C	Device is 7 min ON - 3 min OFF
t = 19.7 °C	Device is 8 min ON - 2 min OFF
t = 19.6 °C	Device is 9 min ON - 1 min OFF
t = 19.5 °C	Device is always on

fig. 36

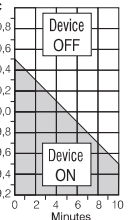

Recommended: a long cycle for systems with high thermal inertia (cast iron radiators, floor systems); a short cycle for systems with low thermal inertia (fan coils).

7 - PROGRAMMABLE FUNCTIONS FOR USE WITH DIFFERENT APPLIANCES

7.3 - SELECTING THE TEMPERATURE SETTING MODE (DIFFERENTIAL ON/OFF or PROPORTIONAL)

This procedure allows you to select the temperature setting mode: either DIFFERENTIAL ON/OFF or PROPORTIONAL.

- Keep **t3** pressed until either **On.OF** = DIFFERENTIAL ON/OFF or **ProP** = PROPORTIONAL blinks on the display.
- Select the desired mode via the **▲ ▼** keys.
- Press **OK** to confirm and return to the set program.

Note: the setting will not be effected by a reset.

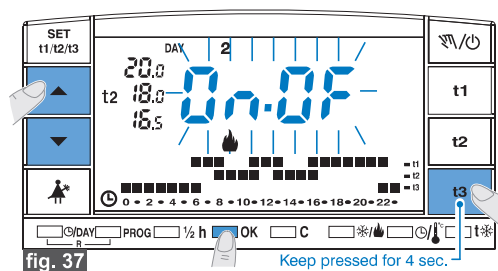

7.4 - TEMPERATURE CORRECTION (OFFSET)

If for any reason the chronothermostat must be installed in a position where the detected temperature can be effected (e.g. an external wall, which in winter is generally colder than the rest of the house), a temperature offset value (temperature correction) can be set between -1.9 and 1.9 °C.

- Keep **t1** (fig.38) pressed until either the Differential set value (example **d06c**) or the Proportional mode cycle duration (example **P 10**) blinks on the display.
- Press **OK** to move on to set the temperature correction (Offset) fig.38.
- Set the desired value by pressing the **▲ ▼** keys.
- Press **OK twice** to confirm and return to the set program.

The room temperature correction implemented, will have effect after a few seconds.

Note: the setting will not be effected by a reset.

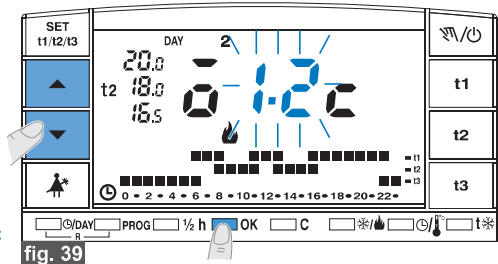
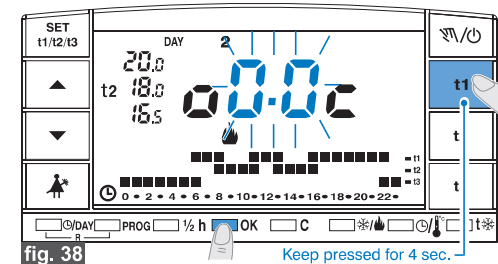

Fig.39 - example of temperature correction setting (Offset): -1.2 °C

7 - PROGRAMMABLE FUNCTIONS FOR USE WITH DIFFERENT APPLIANCES



7.5 - TOTAL Deselection of Antifreeze Temperature

This function allows the thermoregulation to be deactivated when operating with the antifreeze temperature t_{*} selected.

Function on: when utilizing the antifreeze temperature t_{*} , thermoregulation is activated with a fixed factory set point of 5 °C, which can be set between 4 and 12 °C.

Function off: when utilizing the antifreeze temperature t_{*} , thermoregulation is deactivated (use only for systems filled with antifreeze fluid in circuit).

To program the function, press and hold t_{*} (fig.40) until the display shows the caption **ON 5.0c** (function on) or **OFF 5.0c** (function off).

- Press \blacktriangledown to disable the function, then press **OK** to confirm and return to the set program.
- Press \blacktriangle to activate the function, then press **OK twice** to confirm and return to the set program.

Note: this programmed status will not be cleared by a reset.



7.6 - SETTING THE ANTI-FREEZE TEMPERATURE

The anti-freeze temperature setting is factory set at 5 °C, however, you can set a different value between 4 °C and 12 °C.

- Keep t_{*} pressed until **5.0c** blinks on the display (fig.40).
- If the anti-freeze function is enabled (**ON** will blink on the display) move on to the next point, otherwise press \blacktriangle to activate it.
- Press **OK** and **ON** will stop blinking.
- Set the desired value by pressing the \blacktriangle \blacktriangledown keys.
- Press **OK** to confirm and return to the set program (fig.41).

Note: the setting will not be effected by a reset.

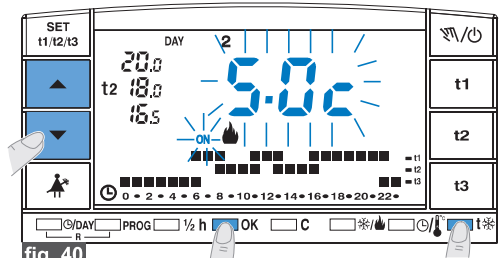

fig. 40

Keep pressed for 4 sec.

Note: this function is factory set to “selected” status and can be deactivated only in heating mode (winter).

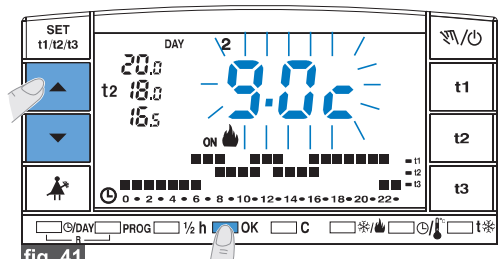

fig. 41

Note: the anti-freeze temperature setting can only be set when in heating mode (winter).

7 - PROGRAMMABLE FUNCTIONS FOR USE WITH DIFFERENT APPLIANCES

7.7 - ANTI-SCALE CYCLE

When this function is selected, the chronothermostat relay will trip every day at 12:00 and activate the controlled appliance (pump, valve) for 2 minutes in order to avoid the formation of scale and prevent seizure that could be caused by prolonged inactivity.

Note: this function is factory set as disabled.

To activate the function, press and hold **OK** until **OFF PU - -** (function off) or **ON PU - -** (function on) blinks on the display.

To activate the function, press the **▲** button.

To deactivate the function, press the **▼** button.

Press **OK** (fig.42) to confirm and return to the set program.

Note: the setting will not be effected by a reset.

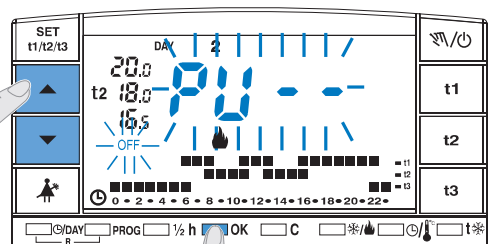

fig. 42

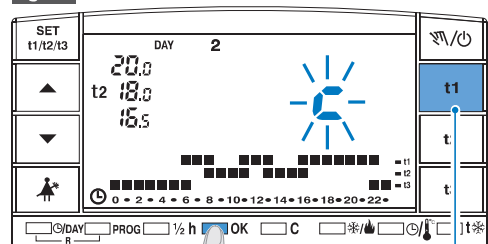

fig. 43

Keep pressed for 4 sec.

7.8 - SETTING THE TEMPERATURE SCALE

The chronothermostat's temperature scale is factory set in degrees Centigrade - to switch to Fahrenheit:

- Keep **t1** (fig.43) pressed until either the Differential set value (example **d06c**) or the Proportional mode cycle duration (example **P 10**) blinks on the display.
- Press **OK twice** and symbol **c** will blink on the display.
- Press **▼** or **▲** to switch from **°C** to **°F** or vice versa.
- Press **OK** (fig.44) to confirm and return to the set program; all the temperature settings will be updated according to the new scale.

Note: the setting will not be effected by a reset.

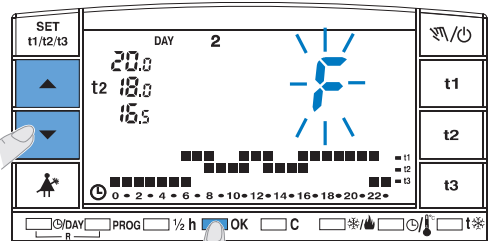
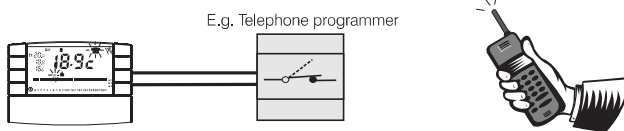

fig. 44

8 - ACTIVATION VIA TELEPHONE PROGRAMMER

8.1 - TELEPHONE PROGRAMMER OPERATING MODE



The telephone programmer allows you to control the chronothermostat from a distance by acting on the contact made at terminals **8** and **9** (see paragraph 4.4 - Electrical Connections).

Telephone programmer	Chronothermostat function
Closed contact	in permanent manual t1 comfort mode
Open contact	in permanent manual t* anti-freeze mode

Closing the contact: When the chronothermostat is set in temporary/permanent manual mode or Holiday mode, it is set in permanent manual mode with **t1 comfort temperature settings**. will blink and will remain fixed on the display to indicate the contact (fig.45).

You can return to the previously set program (P01- P02 - P03 - P04 - P05) by pressing on the chronothermostat. will remain fixed on the display to indicate that the programmer's contact is still closed and it can be opened at a later stage (fig.46).

Opening the contact: The chronothermostat is set in permanent manual mode with **t* anti-freeze** temperature as shown in fig.47 (the air conditioner goes off if the chronothermostat functions in cooling mode). will blink and will remain fixed on the display to indicate the contact.

Press on the chronothermostat to return to the set program.

Note: the opening and closing commands are effective within 1 minute.

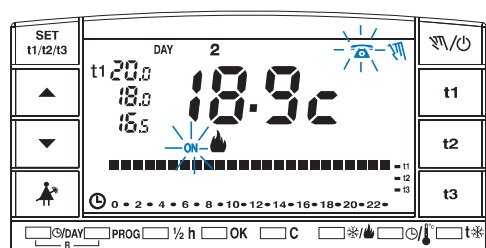

fig. 45

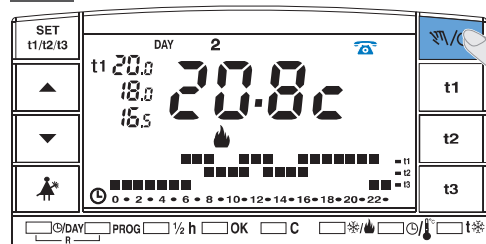

fig. 46

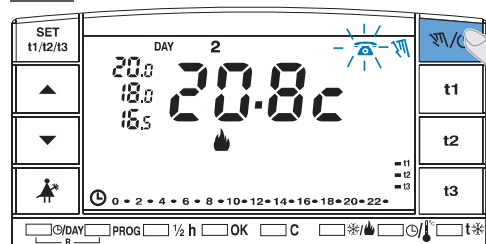

fig. 47