

Type R622 Pressure Reducing Regulator

- Compact Design
- Protective Inlet Screen

- High Capacity
 - Internal Relief
 - Light Weight

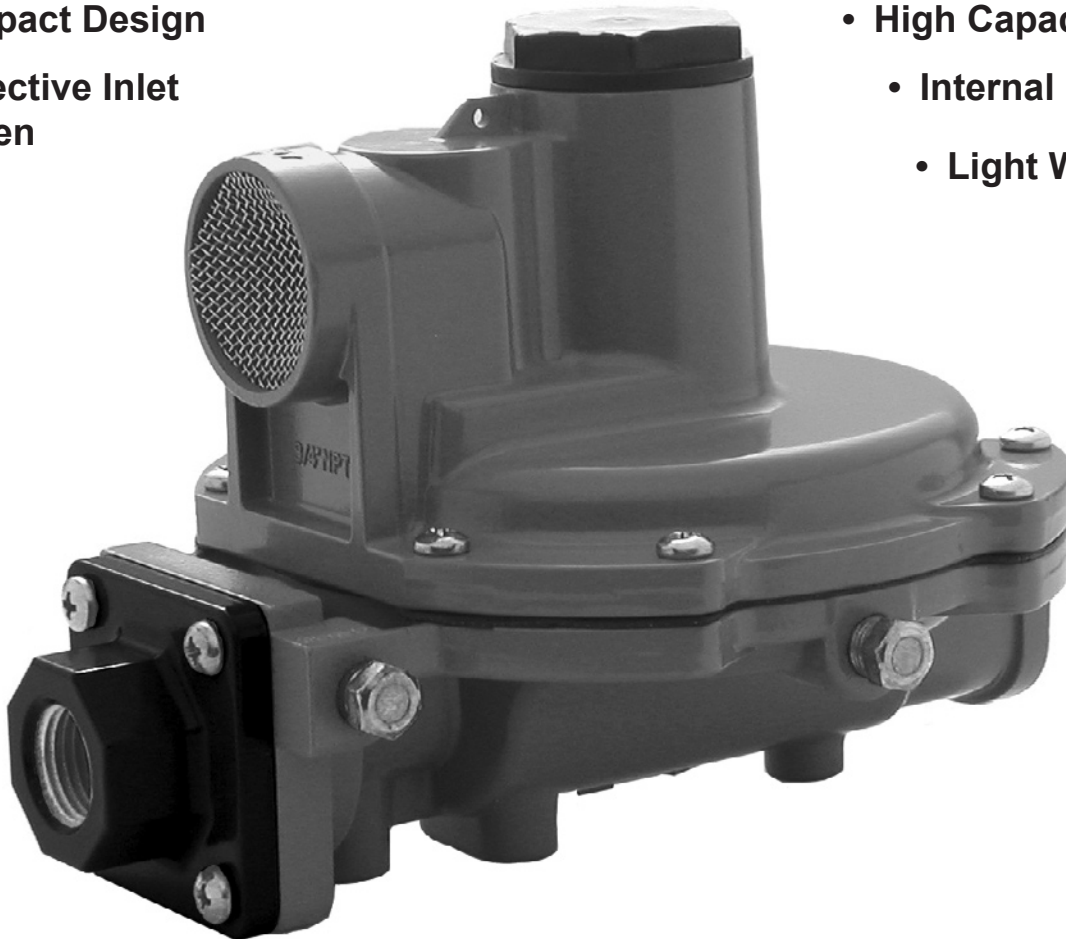

W8806

- Inlet and Outlet Pressure Gauge Taps

Figure 1. Type R622 Pressure Reducing Regulator

Introduction

Type R622 direct-operated, spring-loaded regulators provide economical pressure reducing control in a variety of residential, commercial, and industrial

applications. These regulators can be used with natural, manufactured, or propane gases and have the same inlet and outlet pressure capabilities.



Bulletin 71.1:R622

Specifications

Body Size and End Connection Style⁽¹⁾

1/2 NPT inlet and outlet

Maximum Allowable Inlet Pressure⁽¹⁾

Operating: 125 psig (8,6 bar)

Emergency: 125 psig (8,6 bar)

Except 1.8 to 2.2-inches w.c. (4 to 5 mbar) spring range which has operating and emergency pressures of 60 psig (4,1 bar)

Maximum Allowable Outlet (Casing) Pressure⁽¹⁾

Operating to Avoid Internal Part Damage:

3 psid (0,21 bar d) above outlet pressure setting

Emergency: 20 psi (1,4 bar)

Outlet Pressure Ranges

See Table 1

Orifice Size

1/8-inch (3,2 mm) orifice

Flow Coefficients

Wide-Open C_g for Relief Sizing: 12.5

Wide-Open C_v for Relief Sizing: 0.36

C₁: 35

IEC Sizing Coefficients

X_T: 0.78

F_D: 0.82

F_L: 0.89

Flow Capacities

See Table 2

Pressure Registration

Internal

Relief Performance

See Figure 4

Internal Relief Performance

Start-to-Discharge is 8 to 22-inches w.c.

(20 to 55 mbar) for setpoints from

1.8 to 20-inches w.c. (4 to 50 mbar)

Start-to-Discharge is 140 to 200% over setpoint

from 20-inches w.c. to 2.2 psig (50 to 152 mbar)

Spring Case Vent Connections

3/4 NPT with removable screen

Temperature Capabilities⁽¹⁾

-20° to 160°F (-29° to 71°C)

Approximate Weight

2.35 pounds (1 kg)

Construction Materials

Body, Spring Case, Diaphragm Plate, and Orifice: Aluminum

Diaphragm, Disk, and O-ring: Nitrile (NBR)

Adjusting Screw and Pushpost: Delrin®

Closing Cap: ASA Thermoplastic (UV-Ray Resistant)

Control Spring: Zinc-plated steel

Machine Screw, Spring Seat,

and Lever: Zinc-plated steel

Valve Stem: Zinc

Relief Valve Spring, Relief Spring Retainer, Lever Pin, and Vent Screen: Stainless steel

1. The pressure/temperature limits in this Bulletin or any applicable standard limitation should not be exceeded.
Delrin® is a mark owned by E.I. du Pont de Nemours and Co.

In addition, Type R622 regulators have internal relief across the diaphragm to help minimize overpressure. Any outlet pressure above the start-to-discharge point of the non-adjustable relief valve spring moves the diaphragm off of the relief valve seat, allowing excess pressure to bleed out through the screened spring case vent.

Specifications

The Specifications section lists specifications for Type R622 Pressure Reducing Regulators. As it originally comes from the factory, specifications for a given regulator are stamped on the spring case nameplate.

Table 1. Outlet Pressure Ranges

OUTLET PRESSURE RANGE	CONTROL SPRING PART NUMBER	CONTROL SPRING COLOR CODE	SPRING WIRE DIAMETER, INCHES (mm)	SPRING FREE LENGTH, INCHES (mm)
1.8 to 2.2-inches w.c. (4 to 5 mbar)	T14453T0012	Purple	0.051 (1,30)	3.40 (86,4)
5 to 7-inches w.c. (12 to 17 mbar)	T14398T0012	Orange	0.062 (1,58)	3.40 (86,4)
6.5 to 9-inches w.c. (16 to 22 mbar)	T14399T0012	Yellow	0.067 (1,70)	3.61 (91,7)
9 to 13-inches w.c. (22 to 32 mbar)	T14400T0012	Silver	0.072 (1,83)	4.10 (104)
13 to 20-inches w.c. (32 to 50 mbar)	T14401T0012	Gray	0.080 (2,03)	3.60 (91,4)
16 to 35-inches w.c. (40 to 87 mbar)	T14402T0012	Pink	0.093 (2,36)	3.52 (89,4)
1 to 2.2 psig (69 to 152 mbar)	T14403T0012	Light Blue	0.105 (2,67)	3.66 (93,0)

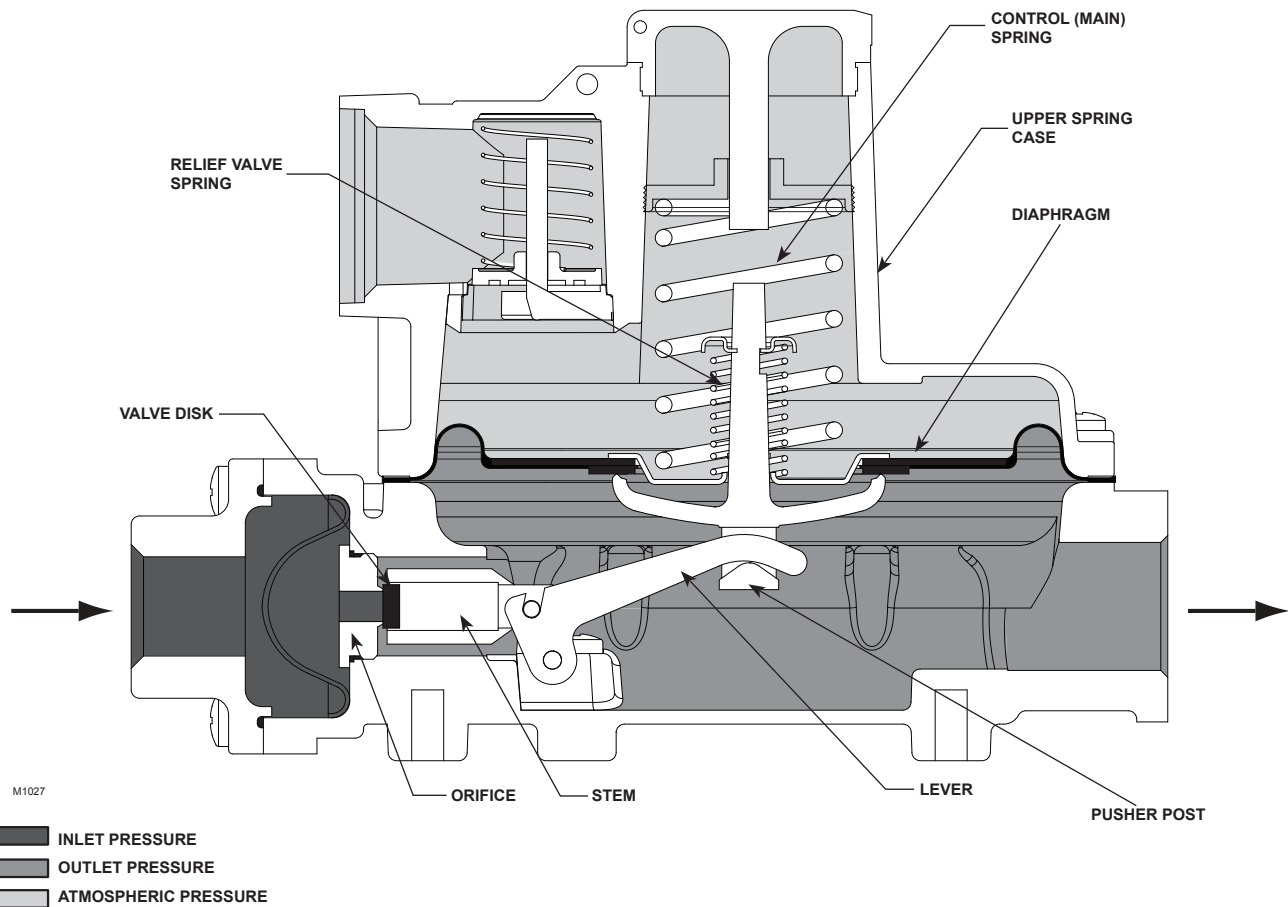

Figure 2. Type R622 Operational Schematic

Principle of Operation

Refer to Figure 2. When downstream demand decreases, the pressure under the diaphragm increases. This pressure overcomes the regulator setting (which is set by the control spring). Through the action of the pusher post assembly, lever, and valve stem, the valve disk moves closer to the orifice and reduces gas flow. If demand downstream increases, pressure under the diaphragm decreases. Spring force pushes the pusher post assembly downward and the valve disk moves away from the orifice allowing flow through the body to the downstream system. Type R622 regulators include an internal relief valve for overpressure protection.

Installation

Type R622 regulator may be installed in any position. However, the spring case vent should be pointed downward. If gas escaping through the Type R622 internal relief valve could constitute a hazard, the spring case vent must be piped to a location where escaping gas will not be hazardous. If the vented gas will be piped to another location, obstruction-free tubing or piping at least equal to the vent, and the end of the vent pipe must be protected from anything that might clog it.

Dimensions are shown in Figure 5.

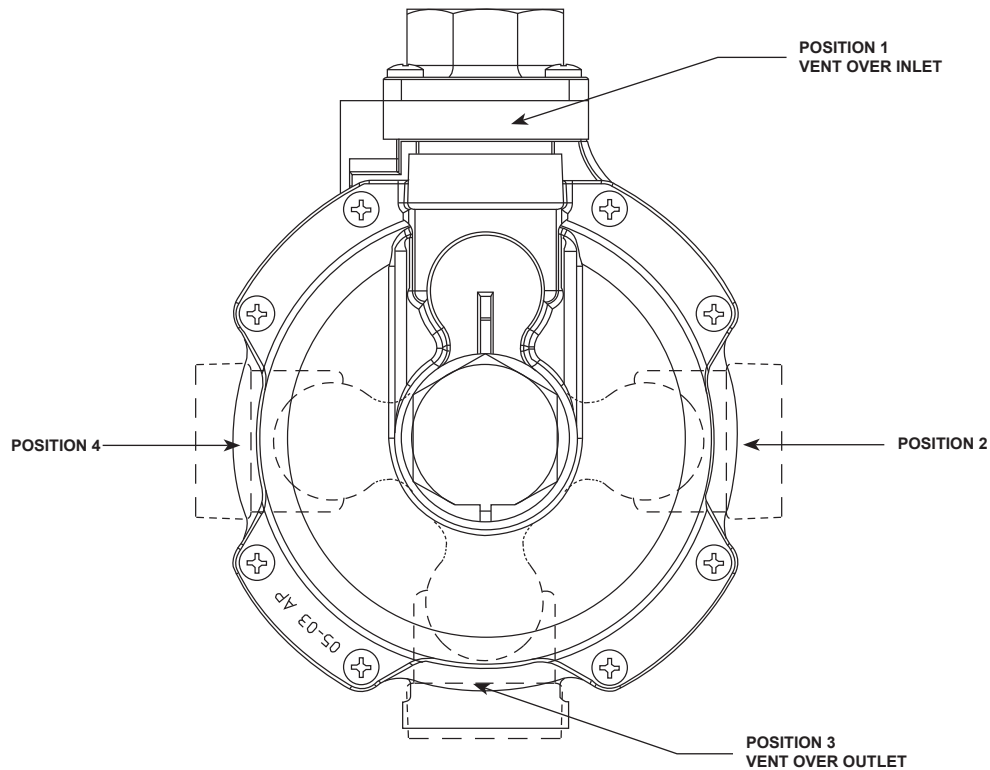

Figure 3. Vent Position

Overpressure Protection

The wide-open C_g for relief sizing (see Specifications section) along with the capacity information should be used in choosing appropriate overpressure protection devices to ensure that none of the limits in the Specifications section are exceeded.

Overpressuring any portion of a regulator or associated equipment may cause leakage, parts damage, or personal injury due to bursting of pressure-containing parts or explosion of accumulated gas. Regulator operation within ratings does not prevent the possibility of damage from external sources or from debris in the pipeline. A regulator should be inspected for damage after any overpressure condition.

Capacity Information

The high efficiency flow-through design provides maximum capacity for a given orifice size. Table 2 gives Type R622 regulator flow capacities at selected inlet pressures and outlet pressure settings. Flows are in SCFH (at 60°F and 14.7 psia) and Nm³/h (at 0°C and 1,01325 bar) of 0.6 specific gravity natural gas. To determine equivalent capacities for air, propane, butane, or nitrogen, multiply the listed SCFH capacity by the following appropriate conversion factor: 0.775 for air, 0.628 for propane, 0.548 for butane, or 0.789 for nitrogen. For gases of other specific gravities, multiply the given SCFH capacity by 0.775 and divide by the square root of the appropriate specific gravity. If capacity is desired in Nm³/h, multiply SCFH by 0.0268.

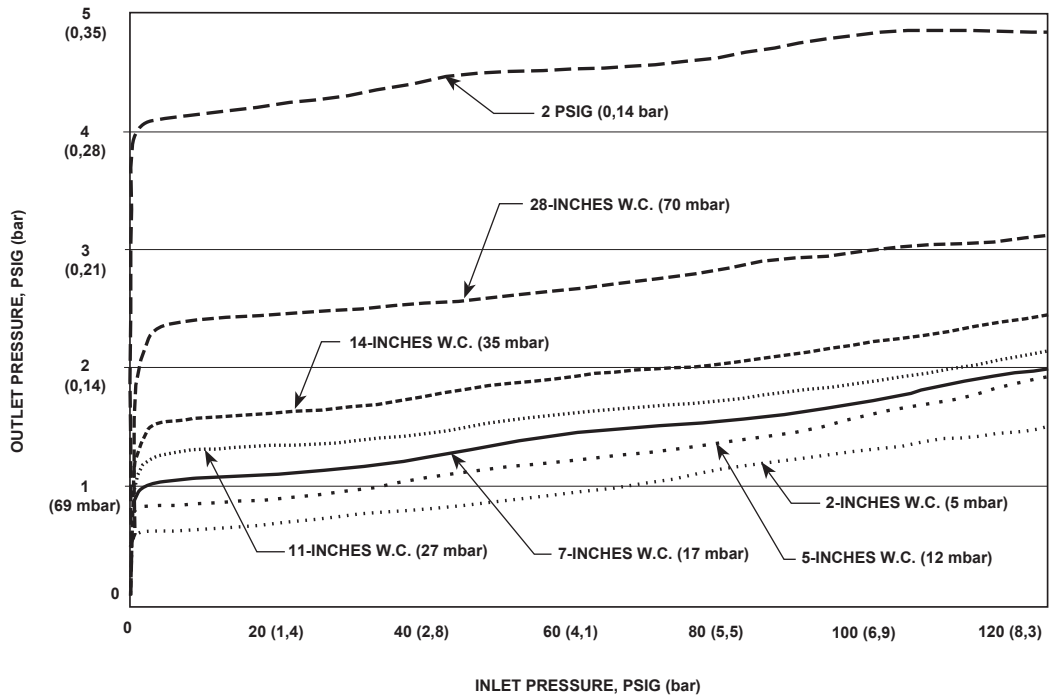

NOTE: TESTED UNDER THE FOLLOWING CONDITIONS: 10 PSIG (0,69 bar) INLET PRESSURE, 7-INCHES W.C. (17 mbar) OUTLET PRESSURE SETTING, AND 50 SCFH (1,3 Nm³/h) OF 0.6 SPECIFIC GRAVITY NATURAL GAS

Figure 4. Industrial Relief Performance

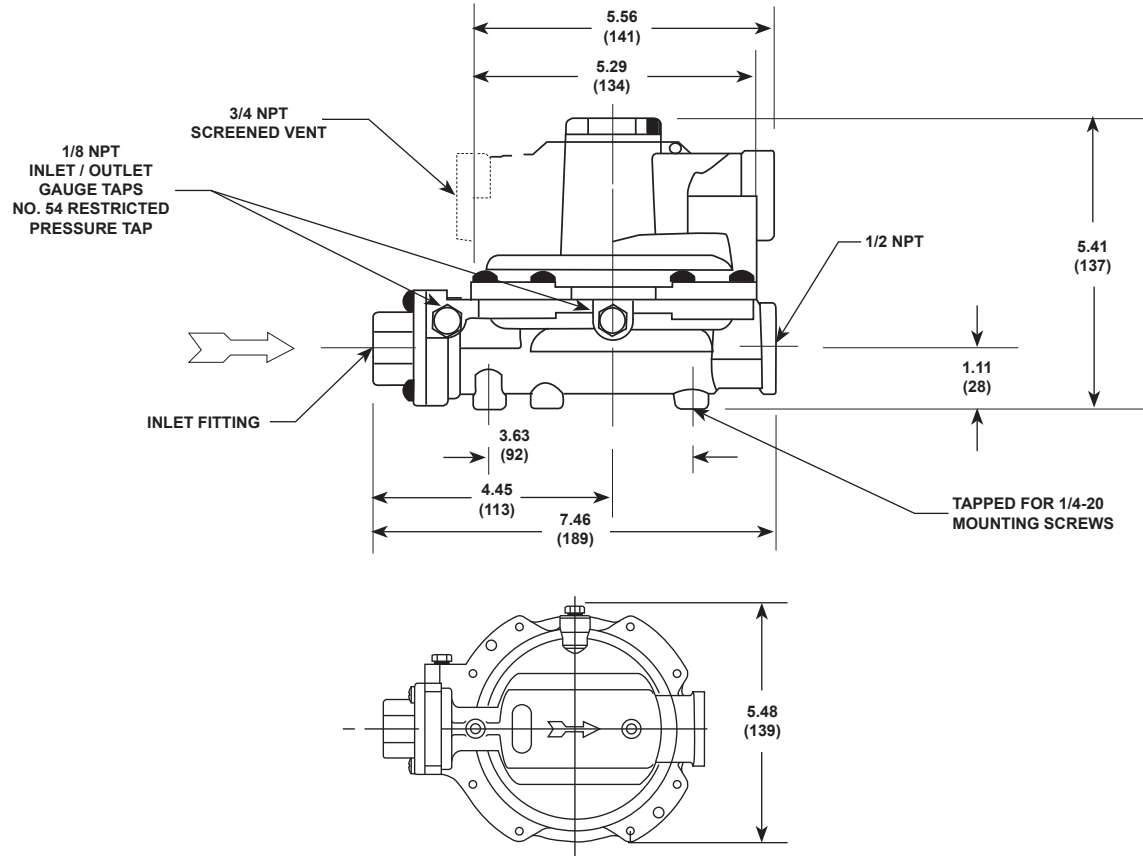

T14439

INCHES (mm)

Figure 5. Dimensions

Bulletin 71.1:R622

Table 2. Typical Regulating Capacities in SCFH (Nm³/h) of 0.6 Specific Gravity Natural Gas for Type R622 Regulator

OUTLET PRESSURE SETTING, CONTROL SPRING RANGE, SPRING PART NUMBER, COLOR CODE, AND DROOP	INLET PRESSURE, PSIG (bar)	1/2 NPT INLET AND OUTLET
Setting: 2-inches w.c (5 mbar) Range: 1.8 to 2.2-inches w.c. (4 to 5 mbar) T14453T0012, Purple Droop: 1-inch w.c. (2 mbar)	5 (0,35)	287 (7,7)
	10 (0,69)	380 (10,2)
	25 (1,7)	451 (12,1)
	50 (3,4)	493 (13,2)
	60 (4,1)	506 (13,6)
Setting: 5-inches w.c. (12 mbar) Ranges: 5 to 7-inches w.c. (12 to 17 mbar) T14398T0012, Orange Droop: 1-inch w.c. (2 mbar)	5 (0,35)	271 (7,3)
	10 (0,69)	367 (9,8)
	25 (1,7)	468 (12,5)
	50 (3,4)	484 (13,0)
	60 (4,1)	428 (11,5)
	75 (5,2)	444 (11,9)
	100 (6,9)	536 (14,4)
Setting: 7-inches w.c. (17 mbar) Range: 6.5 to 9-inches w.c. (16 to 22 mbar) T14399T0012, Yellow Droop: 1-inch w.c. (2 mbar)	125 (8,6)	536 (14,4)
	5 (0,35)	246 (6,6)
	10 (0,69)	347 (9,3)
	25 (1,7)	451 (12,1)
	50 (3,4)	469 (12,6)
	60 (4,1)	477 (12,8)
	75 (5,2)	445 (11,9)
Setting: 11-inches w.c. (27 mbar) Range: 9 to 13-inches w.c. (22 to 32 mbar) T14400T0012, Silver Droop: 2-inches w.c. (5 mbar)	100 (6,9)	507 (13,6)
	125 (8,6)	511 (13,7)
	5 (0,35)	274 (7,3)
	10 (0,69)	401 (10,8)
	25 (1,7)	623 (16,7)
	50 (3,4)	708 (19,0)
	60 (4,1)	735 (19,7)
	75 (5,2)	676 (18,1)
Setting: 14-inches w.c. (35 mbar) Range: 13 to 20-inches w.c. (32 to 50 mbar) T14401T0012, Grey Droop: 2-inches w.c. (5 mbar)	100 (6,9)	721 (19,3)
	125 (8,6)	738 (19,8)
	5 (0,35)	246 (6,6)
	10 (0,69)	364 (9,8)
	25 (1,7)	551 (14,8)
	50 (3,4)	641 (17,2)
	60 (4,1)	661 (17,7)
	75 (5,2)	614 (16,5)
100 (6,9)	677 (18,1)	
125 (8,6)	727 (19,5)	

- continued -

Table 2. Typical Regulating Capacities in SCFH (Nm³/h) of 0.6 specific gravity natural gas for Type R622 Regulator (continued)

OUTLET PRESSURE SETTING, CONTROL SPRING RANGE, SPRING PART NUMBER, COLOR CODE, AND DROOP	INLET PRESSURE, PSIG (bar)	1/2 NPT INLET AND OUTLET
Setting: 1 psig (69 mbar) Range: 16 to 35-inches w.c. (40 to 87 mbar) T14402T0012, Pink Droop: 10%	5 (0,35)	174 (4,7)
	10 (0,69)	337 (9,0)
	25 (1,7)	533 (14,3)
	50 (3,4)	679 (18,2)
	60 (4,1)	708 (19,0)
	75 (5,2)	756 (20,3)
	100 (6,9)	762 (20,4)
	125 (8,6)	796 (21,3)
Setting: 2 psig (0,14 bar) Range: 1.2 to 2.2 psi (83 to 152 mbar) T14403T0012, Light Blue Droop: 10%	5 (0,35)	222 (5,9)
	10 (0,69)	381 (10,2)
	25 (1,7)	630 (16,9)
	50 (3,4)	923 (24,7)
	60 (4,1)	976 (26,2)
	75 (5,2)	1007 (27,0)
	100 (6,9)	1285 (34,4)
	125 (8,6)	1028 (27,6)

For Critical Pressure Drops

Use the following equation for critical pressure drops (absolute outlet pressure equal to or less than one-half of the absolute inlet pressure):

$$Q = P_{1(\text{abs})} C_g (1.29)$$

For Non-Critical Pressure Drops

For pressure drops lower than critical (absolute outlet pressure greater than one-half of absolute inlet pressure), use the following formula:

$$Q = \sqrt{\frac{520}{GT}} C_g P_1 \text{SIN} \left(\frac{3417}{C_1} \sqrt{\frac{\Delta P}{P_1}} \right) \text{DEG}$$

where,

- Q = gas flow rate, SCFH
- G = specific gravity of the gas
- T = absolute temperature of gas at inlet, °Rankine
- C_g = gas sizing coefficient
- P₁ = absolute inlet pressure, psia
- C₁ = flow coefficient
- ΔP = pressure drop across the regulator, psi

Then, if capacity is desired in normal cubic meters per hour at 0°C and 1,01325 bar, multiply SCFH by 0.0268.

Ordering Information

Carefully review each specification and complete the Ordering Guide. Send the Ordering Guide to your local Sales Office.

Ordering Guide

Outlet Pressure Range (Select One)

- 1.8 to 2.2-inches w.c. (4 to 5 mbar), Purple***
- 5 to 7-inches w.c. (12 to 17 mbar), Orange***
- 6.5 to 9-inches w.c. (16 to 22 mbar), Yellow***
- 9 to 13-inches w.c. (22 to 32 mbar), Silver***
- 13 to 20-inches w.c. (32 to 50 mbar), Gray***
- 16 to 35-inches w.c. (40 to 87 mbar), Pink***
- 1 to 2.2 psig (69 to 152 mbar), Light Blue***

Vent Position (Select One)

- Position 1 (vent over inlet)***
- Position 2***
- Position 3 (vent over outlet) ***
- Position 4***

Regulators Quick Order Guide	
***	Readily Available for Shipment
**	Allow Additional Time for Shipment
*	Special Order, Constructed from Non-Stocked Parts. Consult your local Sales Office for Availability.
Availability of the product being ordered is determined by the component with the longest shipping time for the requested construction.	

Specification Worksheet	
Application:	
Specific Use	_____
Line Size	_____
Fluid Type	_____
Specific Gravity	_____
Temperature	_____
Does the Application Require Overpressure Protection?	
<input type="checkbox"/> Yes	<input type="checkbox"/> No
Pressure:	
Maximum Inlet Pressure	_____
Minimum Inlet Pressure	_____
Differential Pressure	_____
Set Pressure	_____
Maximum Flow	_____
Accuracy Requirements:	
Less Than of Equal To:	
<input type="checkbox"/> 5%	<input type="checkbox"/> 10% <input type="checkbox"/> 20% <input type="checkbox"/> 40%
Construction Material Requirements (if known):	

Industrial Regulators

Emerson Process Management Regulator Technologies, Inc.

USA - Headquarters
 McKinney, Texas 75069-1872 USA
 Tel: 1-800-558-5853
 Outside U.S. 1-972-548-3574

Asia-Pacific
 Shanghai, China 201206
 Tel: +86 21 2892 9000

Europe
 Bologna, Italy 40013
 Tel: +39 051 4190611

Middle East and Africa
 Dubai, United Arab Emirates
 Tel: +971 4811 8100

Natural Gas Technologies

Emerson Process Management Regulator Technologies, Inc.

USA - Headquarters
 McKinney, Texas 75069-1872 USA
 Tel: 1-800-558-5853
 Outside U.S. 1-972-548-3574

Asia-Pacific
 Singapore, Singapore 128461
 Tel: +65 6777 8211

Europe
 Bologna, Italy 40013
 Tel: +39 051 4190611
 Gallardon, France 28320
 Tel: +33 (0)2 37 33 47 00

TESCOM

Emerson Process Management Tescom Corporation

USA - Headquarters
 Elk River, Minnesota 55330-2445 USA
 Tel: 1-763-241-3238

Europe
 Selmsdorf, Germany 23923
 Tel: +49 (0) 38823 31 0

For further information visit www.fisherregulators.com

The Emerson logo is a trademark and service mark of Emerson Electric Co. All other marks are the property of their prospective owners. Fisher is a mark owned by Fisher Controls, Inc., a business of Emerson Process Management.

The contents of this publication are presented for informational purposes only, and while every effort has been made to ensure their accuracy, they are not to be construed as warranties or guarantees, express or implied, regarding the products or services described herein or their use or applicability. We reserve the right to modify or improve the designs or specifications of such products at any time without notice.

Emerson Process Management does not assume responsibility for the selection, use or maintenance of any product. Responsibility for proper selection, use and maintenance of any Emerson Process Management product remains solely with the purchaser.