

ITS 96 EN 2-4 / EN 3-6



+ G 96 N 20

WN 055388 45532, 12/16

CE	DORMA GmbH + Co. KG Postfach 4009 58 247 Ennepetal	04
	0432-BPR-0009	EN 1154;1996+A1;2002
	DOP_0051 / DOP_0052	3 8 2-4 1 1 4 3 8 3-6 1 1 4

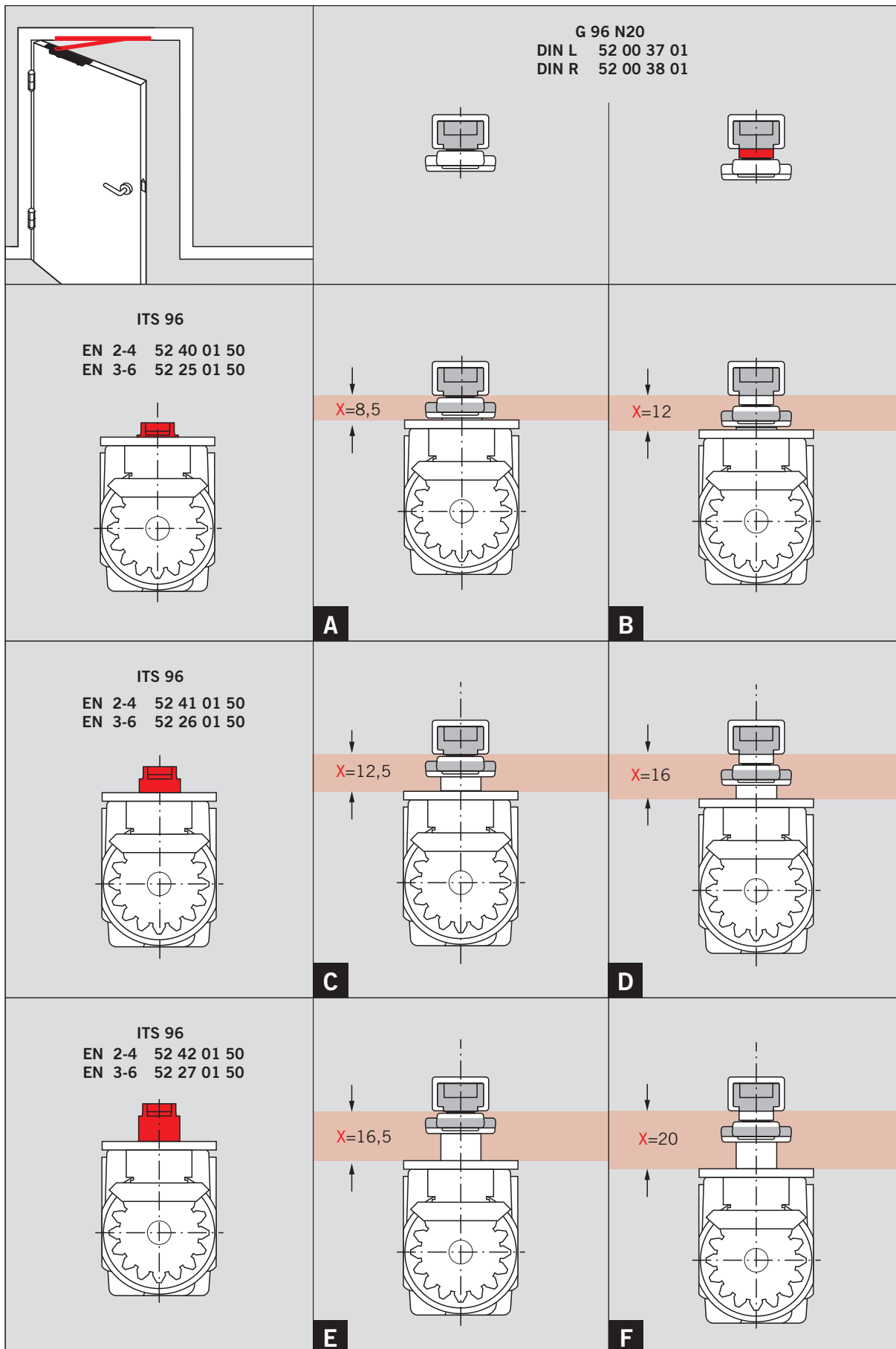

ITS 96 EN 2-4 / EN 3-6

+ G 96 N 20

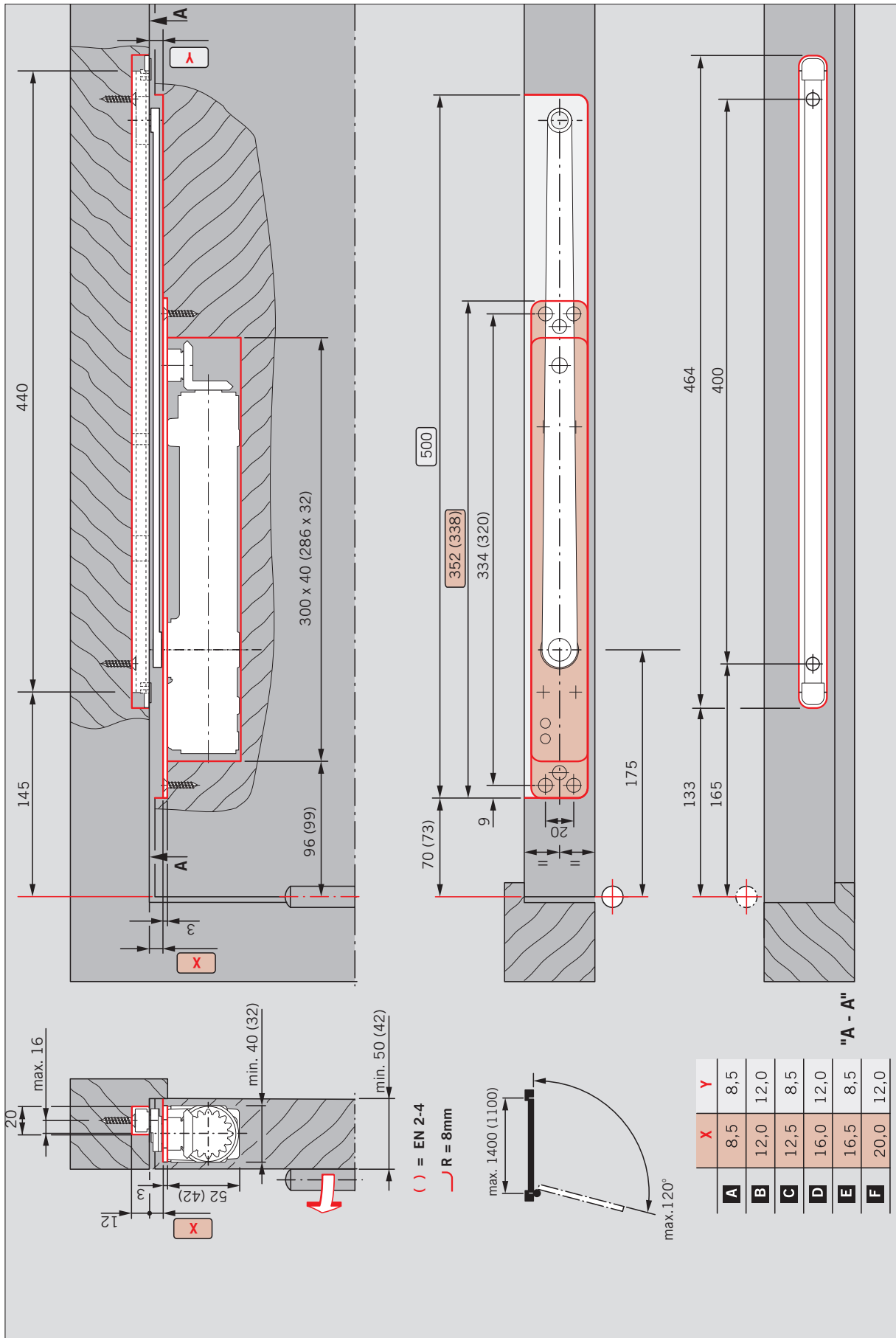

ITS 96 EN 2-4 / EN 3-6

+ G 96 N 20

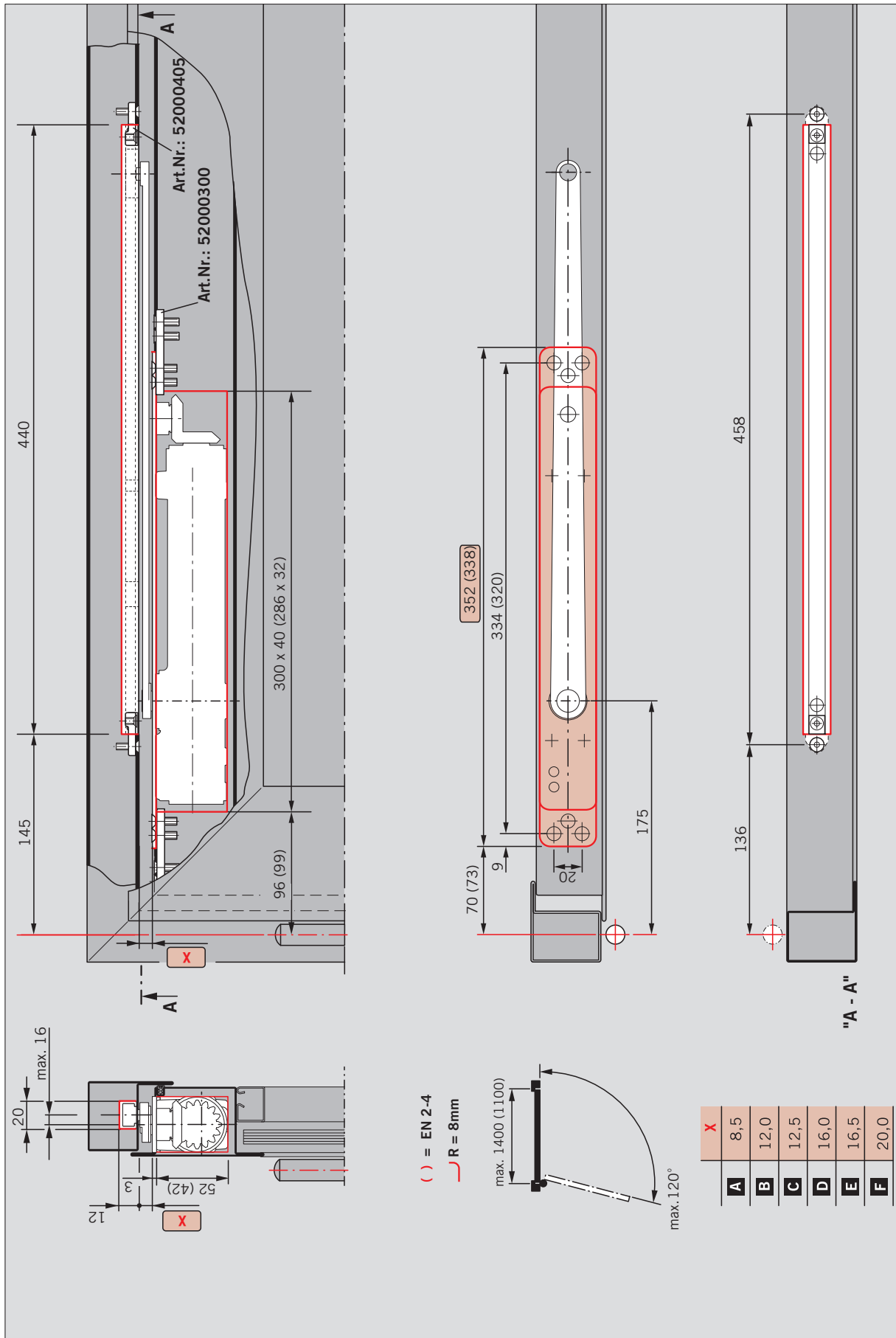

ITS 96 EN 2-4 / EN 3-6

+ G 96 N 20

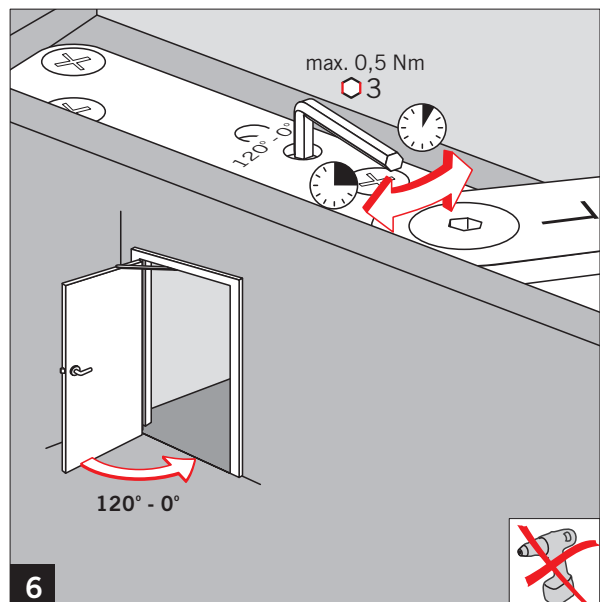
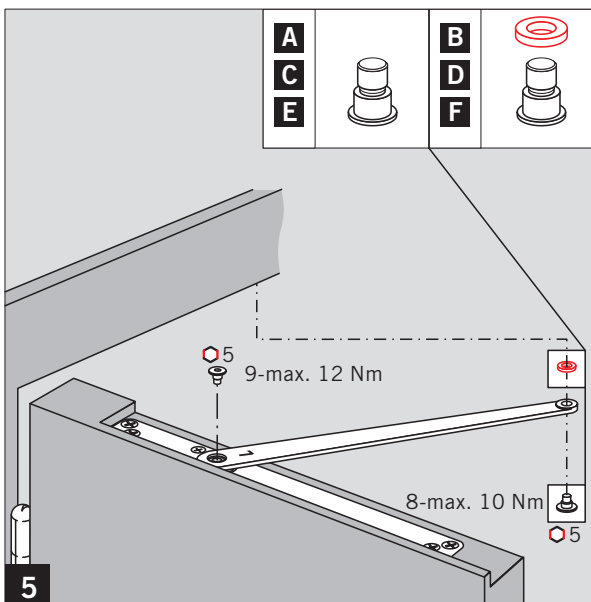
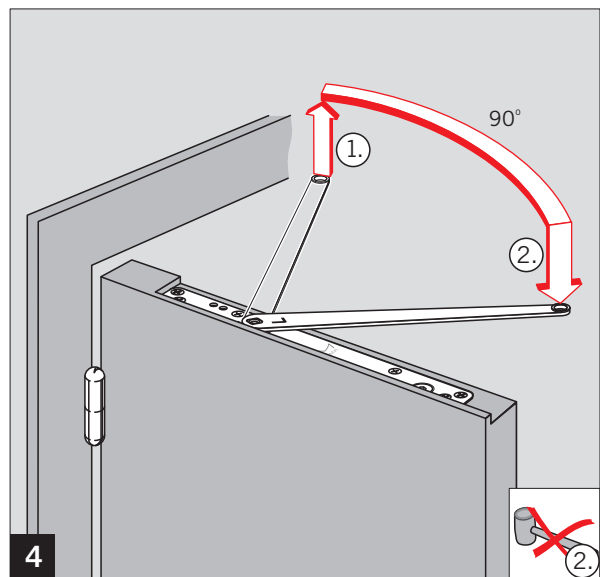
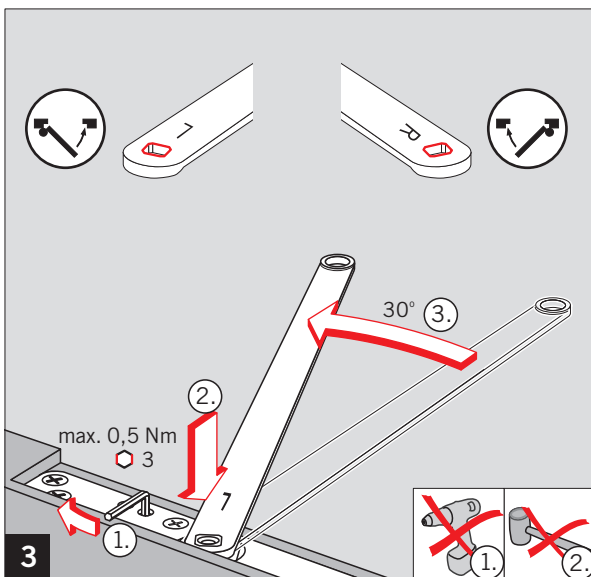
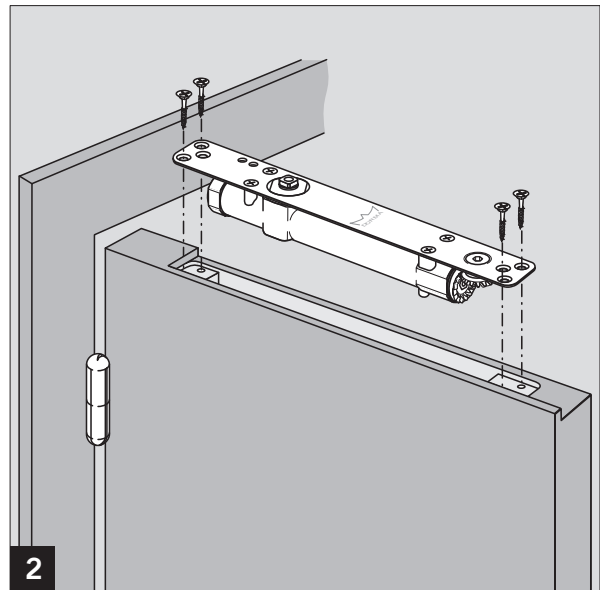
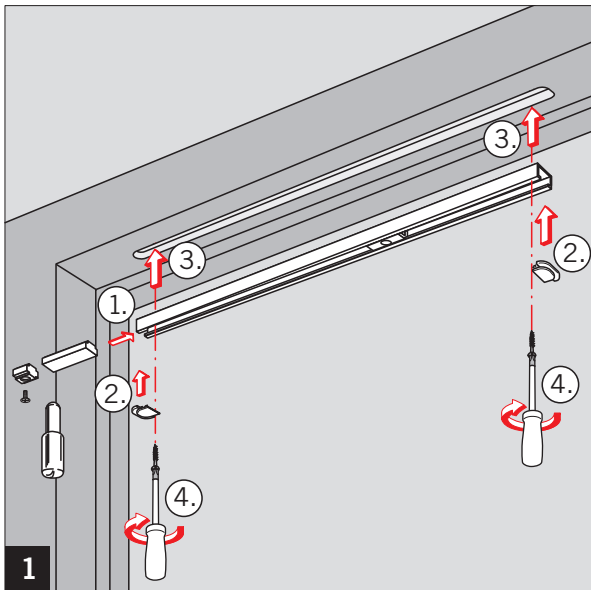

ITS 96 EN 2-4 / EN 3-6

+ G 96 N 20

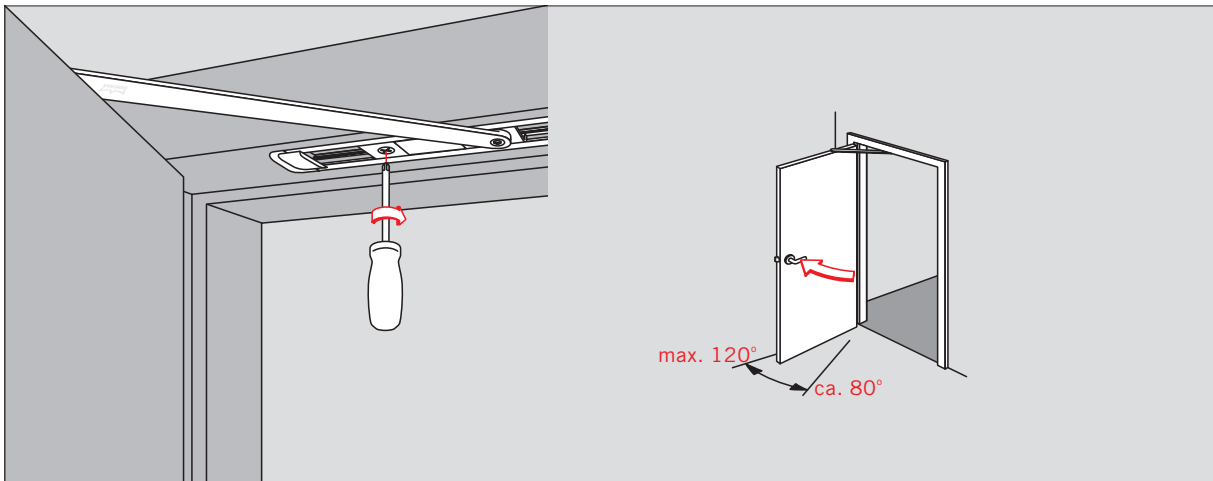
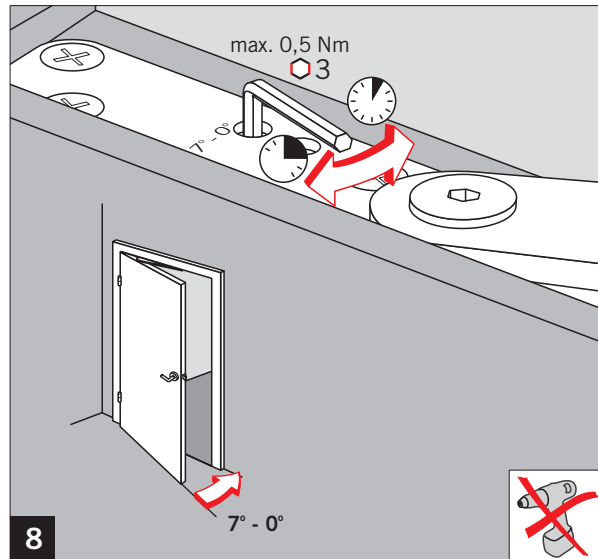
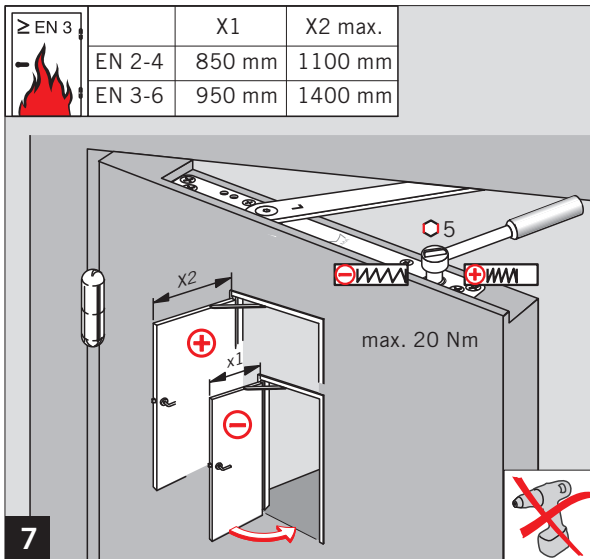

 Durch den Einsatz der Öffnungsbegrenzung soll verhindert werden, daß eine **normal** geöffnete Tür gegen angrenzende Wände stößt. Sie ist keine Überlastsicherung und ersetzt in vielen Anwendungsfällen nicht einen Türstopper. Öffnungsbegrenzung einstellbar zwischen 80° und max. 120°.

The deadstop helps to prevent damage to the door and wall when the door is opened **normally**. The deadstop is not abuse resistant, and cannot replace a door stop in many situations. Deadstop adjustable between 80° and 120° maximum.

La butée de limitation à l'ouverture réduit considérablement les risques d'endommagement du mur ou de la porte en ouverture **normale**. La butée de limitation à l'ouverture ne remplace pas le butoir de porte. Butée de limitation à l'ouverture. Réglable entre 80° et 120° maximum.

De openingsbegrenzing voorkomt dat een **normaal** geopende deur tegen aanliggende wanden stoot. Deze is geen overbelastingsbeveiliging en dient doorgaans niet ter vervanging van de deurbuffer. Openingsbegrenzing instelbaar tussen 80° en max. 120°.

D

Il limitatore di apertura aiuta nella prevenzione di danni alla porta e alle strutture circostanti quando l'anta è **normalmente** aperta. Non sforzare il limitatore di apertura, questo elemento non trattiene l'anta in posizione porta aperta. Il limitatore di apertura si posiziona tra gli 80° e 120° massimo.

I

GB

Con la limitación de apertura se pretende evitar que una puerta que se abra en condiciones de uso **normal** choque contra la pared. No es una protección contra sobrecargas y, en muchos casos, no sustituye a un tope de puerta. Puede ajustarse entre un ángulo de 80° y 120° como máximo.

E

F

NL

9



ITS 96 EN 2-4 / EN 3-6

—
+ G 96 N 20

Änderungen vorbehalten
Subject to change without notice