

# HYDRAULIC MOTORS MR

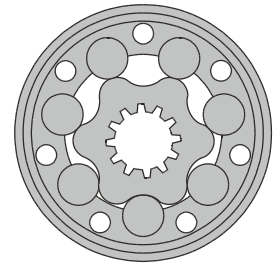

## APPLICATION

- » Conveyors
- » Feeding mechanism of robots and manipulators
- » Metal working machines
- » Textile machines
- » Machines for agriculture
- » Food industries
- » Grass cutting machinery etc.



## CONTENTS

Specification data .....29÷30  
 Function diagrams .....31÷35  
 Dimensions and mounting ..... 36  
 Shaft extensions ..... 24  
 Permissible shaft loads ..... 25  
 Permissible shaft Seal Pressure ... 26  
 Order code ..... 37

## OPTIONS

- » Model- Spool valve, roll-gerotor
- » Flange mount
- » Motor with needle bearing
- » Side and rear ports
- » Shafts- straight, splined and tapered
- » Shaft seal for high and low pressure
- » Metric and BSPP ports
- » Speed sensing
- » Other special features

## GENERAL

Displacement,	[cm <sup>3</sup> /rev.]	51,5 ÷ 397
Max. Speed,	[RPM]	150 ÷ 775
Max. Torque,	[daNm]	10,1 ÷ 61
Max. Output,	[kW]	5 ÷ 13
Max. Pressure Drop,	[bar]	70 ÷ 175
Max. Oil Flow,	[l/min]	40 ÷ 60
Min. Speed,	[RPM]	10
Pressure fluid	Mineral based- HLP(DIN 51524) or HM(ISO 6743/4)	
Temperature range,	[°C]	-30 ÷ 90
Optimal Viscosity range,	[mm <sup>2</sup> /s]	20 ÷ 75
Filtration	ISO code 20/16 (Min. recommended fluid filtration of 25 micron)	

**Oil flow in drain line**

Pressure drop (bar)	Viscosity (mm <sup>2</sup> /s)	Oil flow in drain line (l/min)
100	20	2,5
	35	1,8
140	20	3,5
	35	2,8

**Pressure Losses**

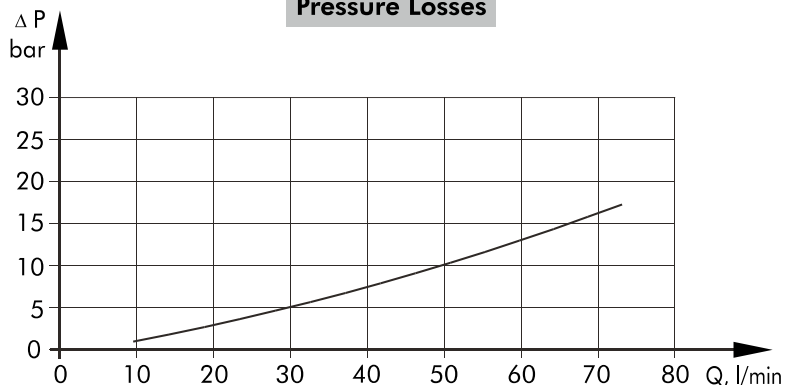

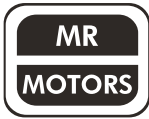

## SPECIFICATION DATA

Specification Data for MR... motors with C, CO, SH, K and SA shafts.  
( $\varnothing 28,56$  sealing diameter)

Type	MR									
	50	80	100	125	160	200	250	315	400	
Displacement, [cm <sup>3</sup> /rev.]	51,5	80,3	99,8	125,7	159,6	199,8	250,1	315,7	397	
Max. Speed, [RPM]	cont.	775	750	600	475	375	300	240	190	150
	int.*	970	940	750	600	470	375	300	240	190
Max. Torque [daNm]	cont.	10	20	24	30	39	38,5	39	36	38
	int.*	13	22	28	34	43	46	47	47	47
	peak**	17	27	32	37	46	56	60	61	61
Max. Output, [kW]	cont.	7	12,5	13	12,5	11,5	9	8	5	4,8
	int.*	8,5	15	15	14,5	14	12	9,5	8	6,8
Max. Pressure Drop [bar]	cont.	140	175	175	175	175	140	110	85	65
	int.*	175	200	200	200	200	175	140	115	90
	peak**	225	225	225	225	225	225	200	150	115
Max. Oil Flow [l/min]	cont.	40	60	60	60	60	60	60	60	60
	int.*	50	75	75	75	75	75	75	75	75
Max. Inlet Pressure [bar]	cont.	175	175	175	175	175	175	175	175	175
	int.*	200	200	200	200	200	200	200	200	200
	peak**	225	225	225	225	225	225	225	225	225
Max. Return Pressure with Drain Line [bar]	cont.	175	175	175	175	175	175	175	175	175
	int.*	200	200	200	200	200	200	200	200	200
	peak**	225	225	225	225	225	225	225	225	225
Max. Starting Pressure with Unloaded Shaft, [bar]		10	10	10	9	7	5	4	3	3
Min. Starting Torque [daNm]	at max. press. drop cont.	8	15	20	25	32	33	31	31,5	31,5
	at max. press. drop int.*	10	17	23	28	37	40	48	50	50
Min. Speed***, [RPM]		10	10	10	10	10	10	10	10	10
Weight, avg. [kg] For rear ports: +0,650 kg	MR(F)	6,8	6,9	7,2	7,3	7,5	8	8,4	9,1	9,8
	MRQ(N)	6,2	6,3	6,6	6,8	7,0	7,2	7,8	8,6	9,3

\* Intermittent operation: the permissible values may occur for max. 10% of every minute.

\*\* Peak load: the permissible values may occur for max. 1% for every minute.

\*\*\* For speeds of 10 RPM or lower, consult factory or your regional manager.

1. Intermittent speed and intermittent pressure drop must not occur simultaneously!
2. Recommended filtration is per ISO cleanliness code 20/16. A nominal filtration of 25 micron or better.
3. Recommended using a premium quality, anti-wear type mineral based hydraulic oil HLP(DIN51524) or HM (ISO 6743/4).  
If using synthetic fluids consult the factory for alternative seal materials.
4. Recommended minimum oil viscosity 13 mm<sup>2</sup>/s at operating temperatures.
5. Recommended maximum system operating temperature - 82°C.
6. To assure optimum motor life fill with fluid prior to loading and run at moderate load and speed for 10-15 min.

**FUNCTION DIAGRAMS**

**MR 50**

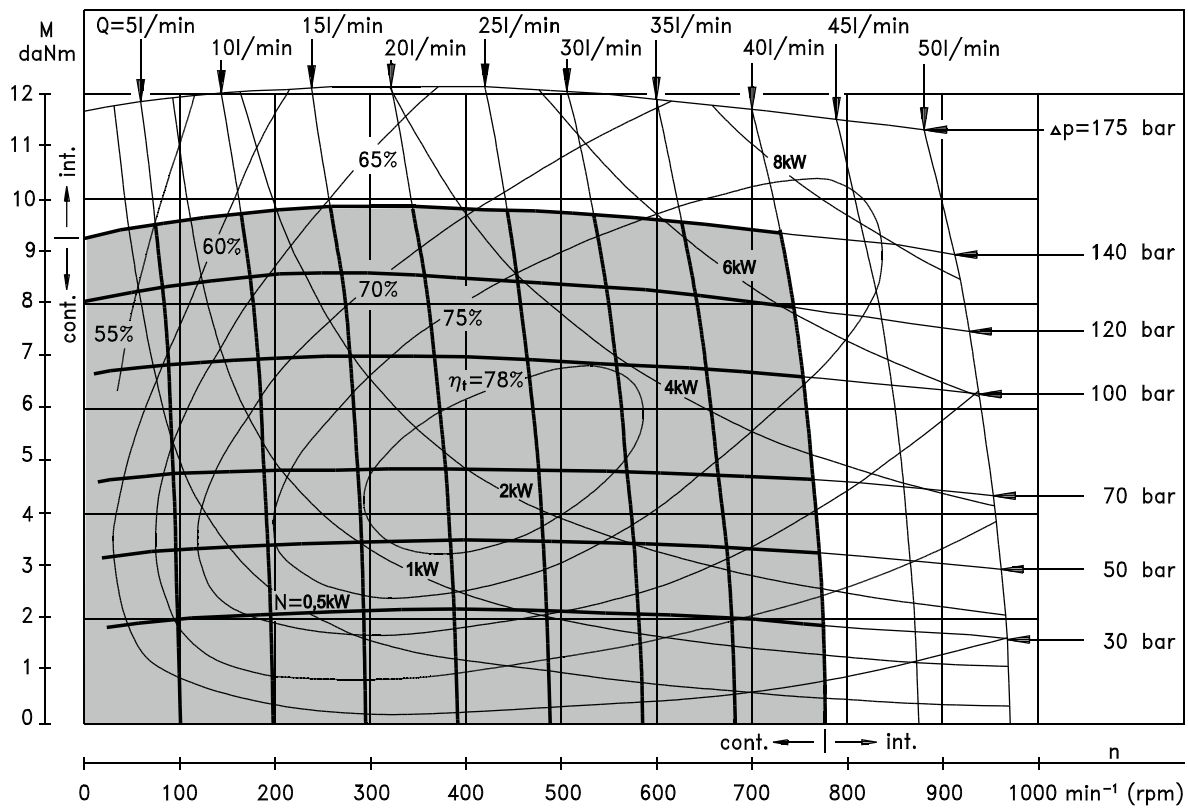

**MR 80**

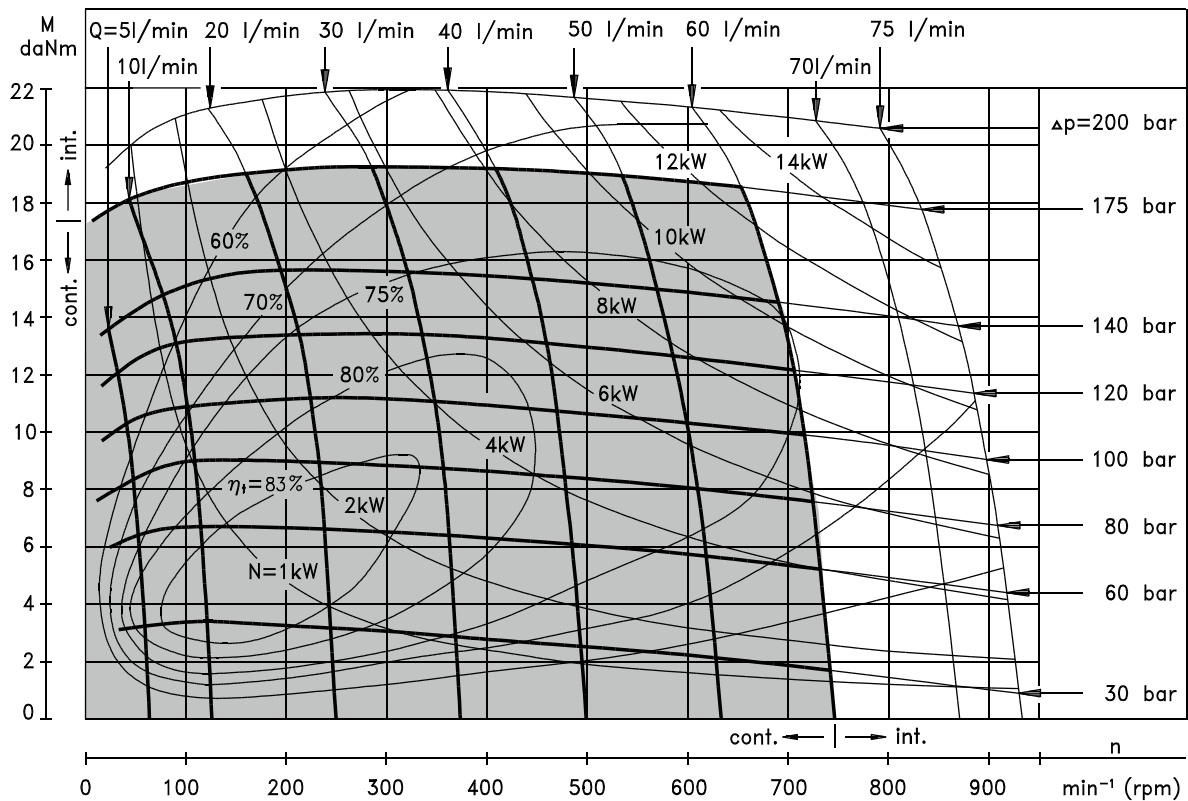

The function diagrams data was collected at back pressure 5 ÷ 10 bar and oil with viscosity of 32 mm<sup>2</sup>/s at 50° C.

**FUNCTION DIAGRAMS**

**MR 100**

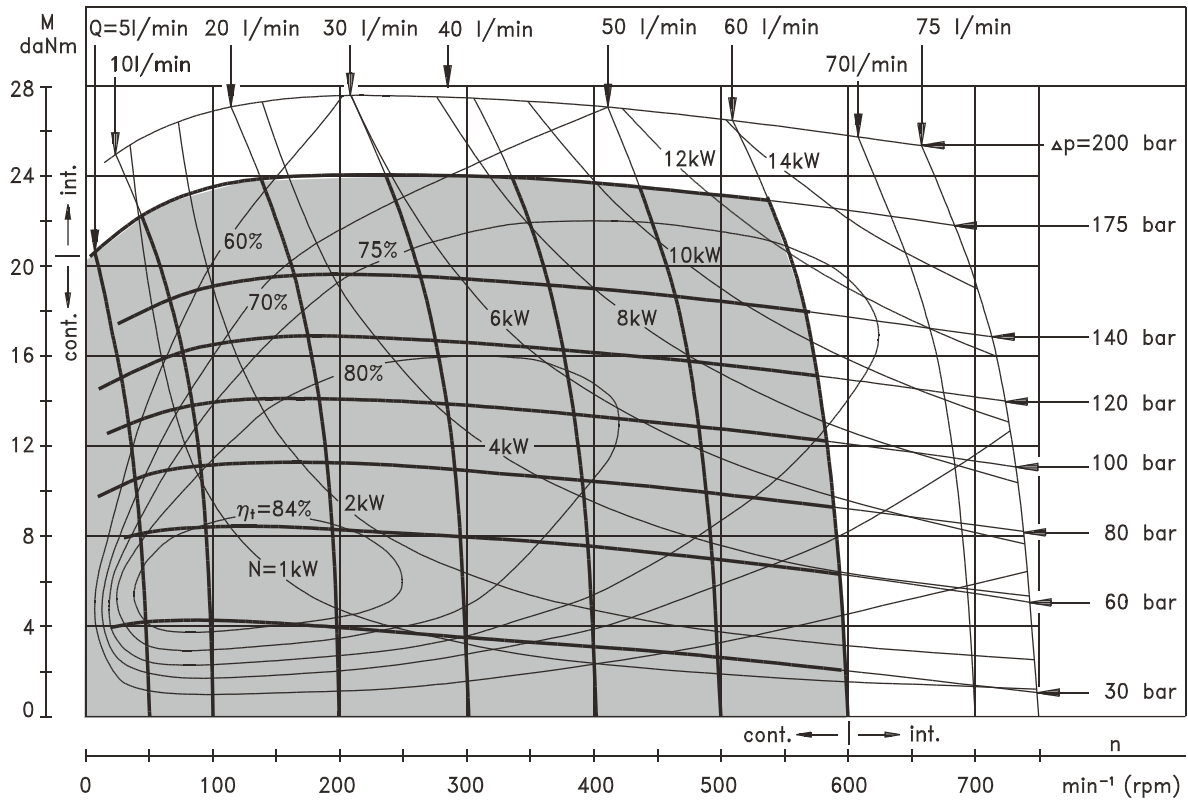

**MR 125**

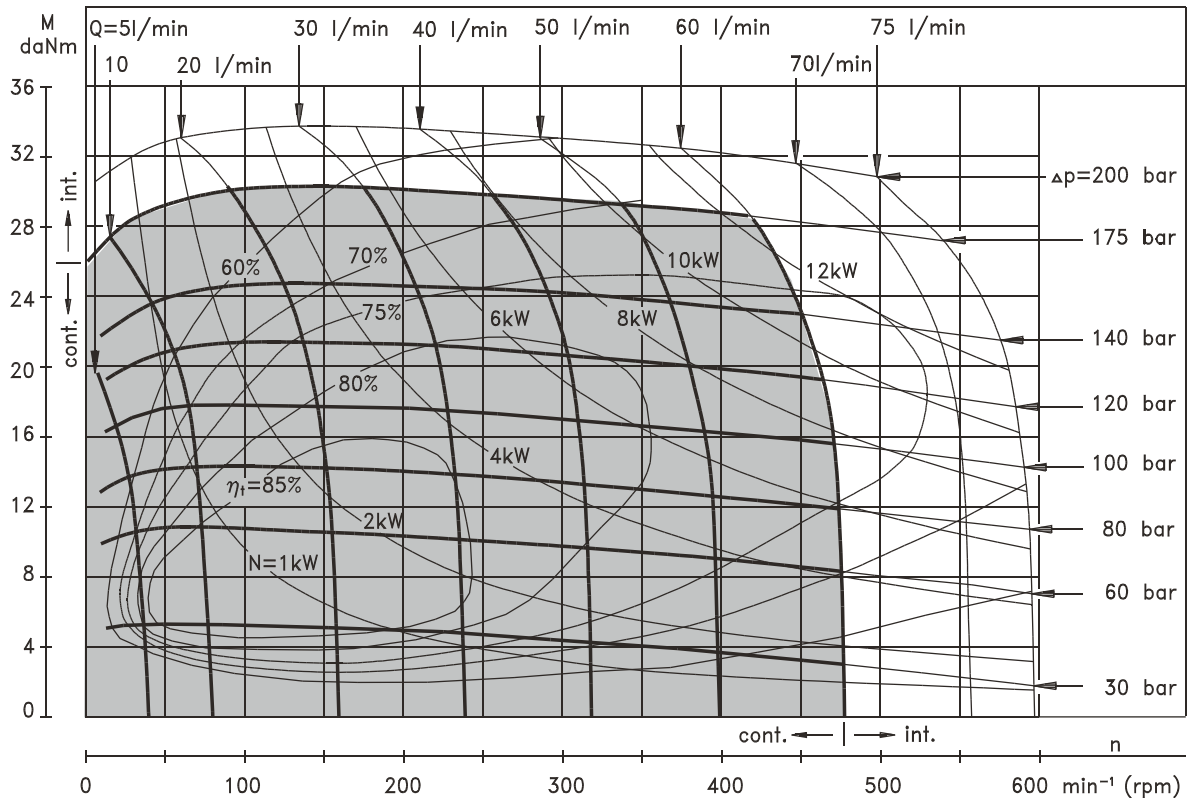

The function diagrams data was collected at back pressure  $5 \div 10$  bar and oil with viscosity of  $32 \text{ mm}^2/\text{s}$  at  $50^\circ \text{C}$ .

**FUNCTION DIAGRAMS**

**MR 160**

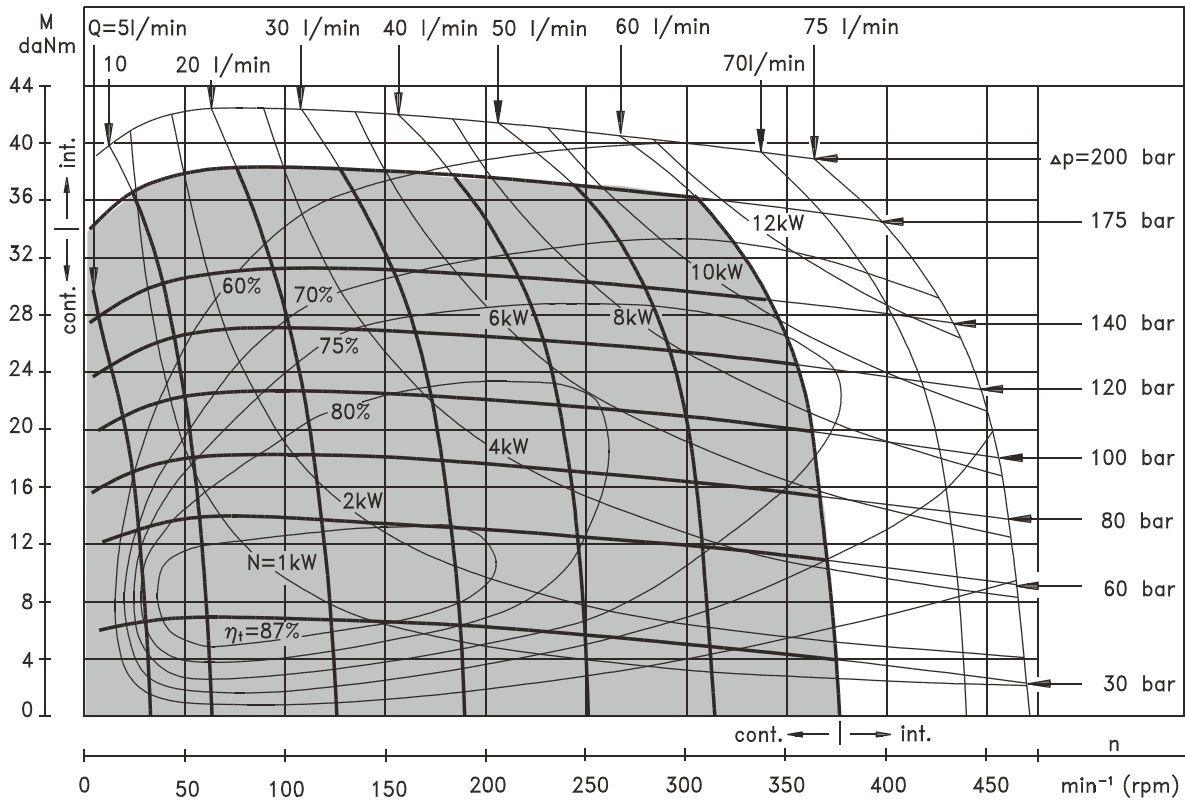

**MR 200**

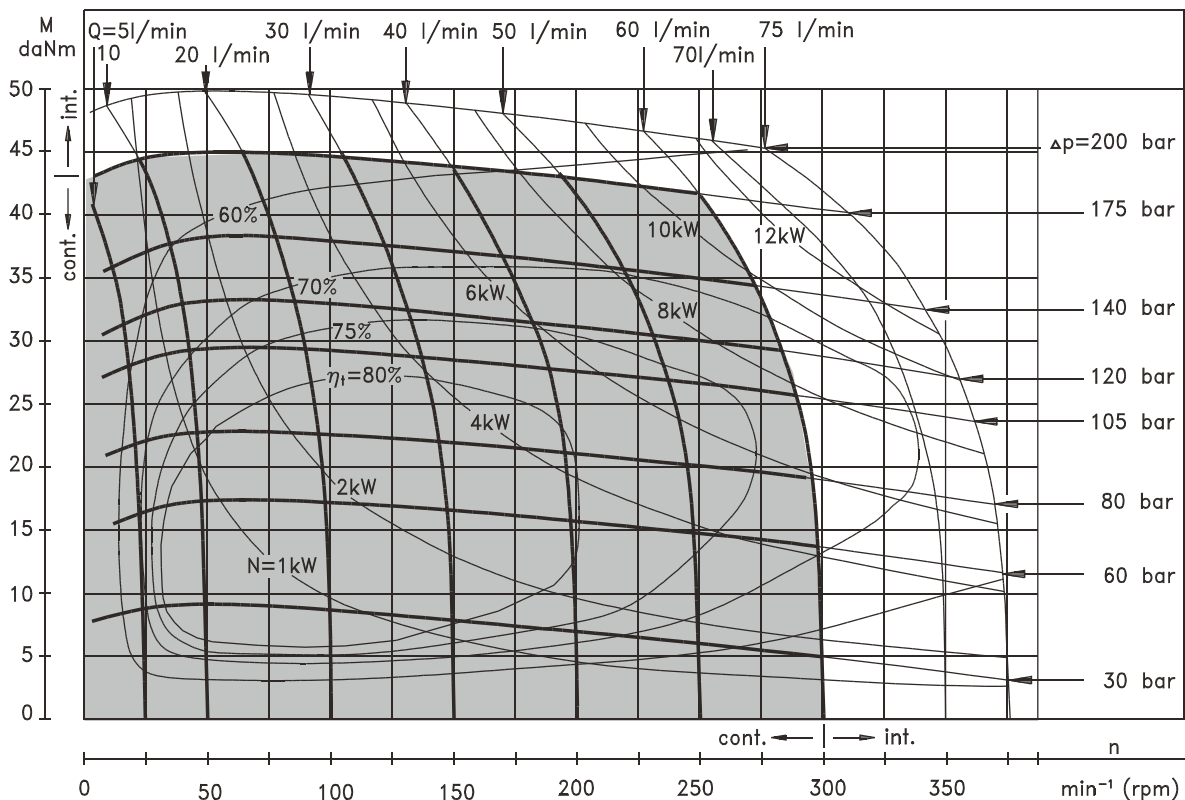

The function diagrams data was collected at back pressure 5 ÷ 10 bar and oil with viscosity of 32 mm<sup>2</sup>/s at 50° C.

**FUNCTION DIAGRAMS**

**MR 250**

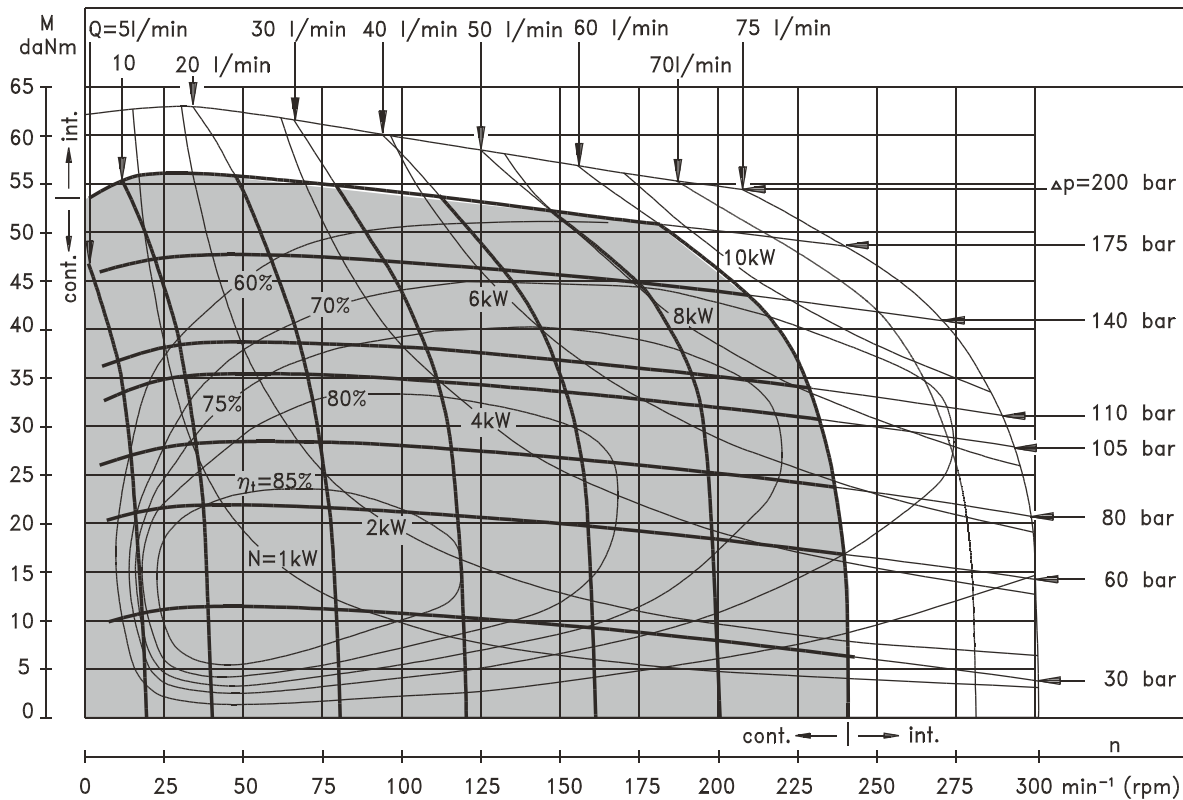

**MR 315**

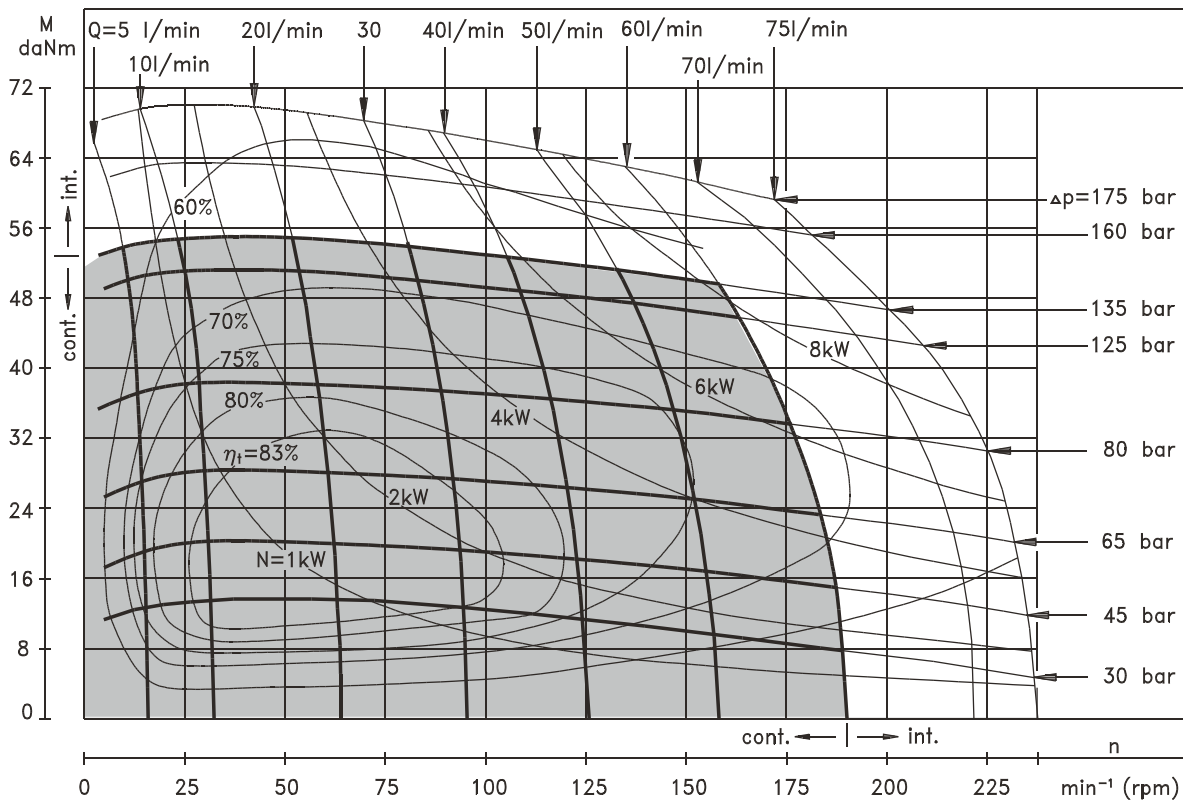

The function diagrams data was collected at back pressure 5 ÷ 10 bar and oil with viscosity of 32 mm<sup>2</sup>/s at 50° C.

**FUNCTION DIAGRAM**

**MR 400**

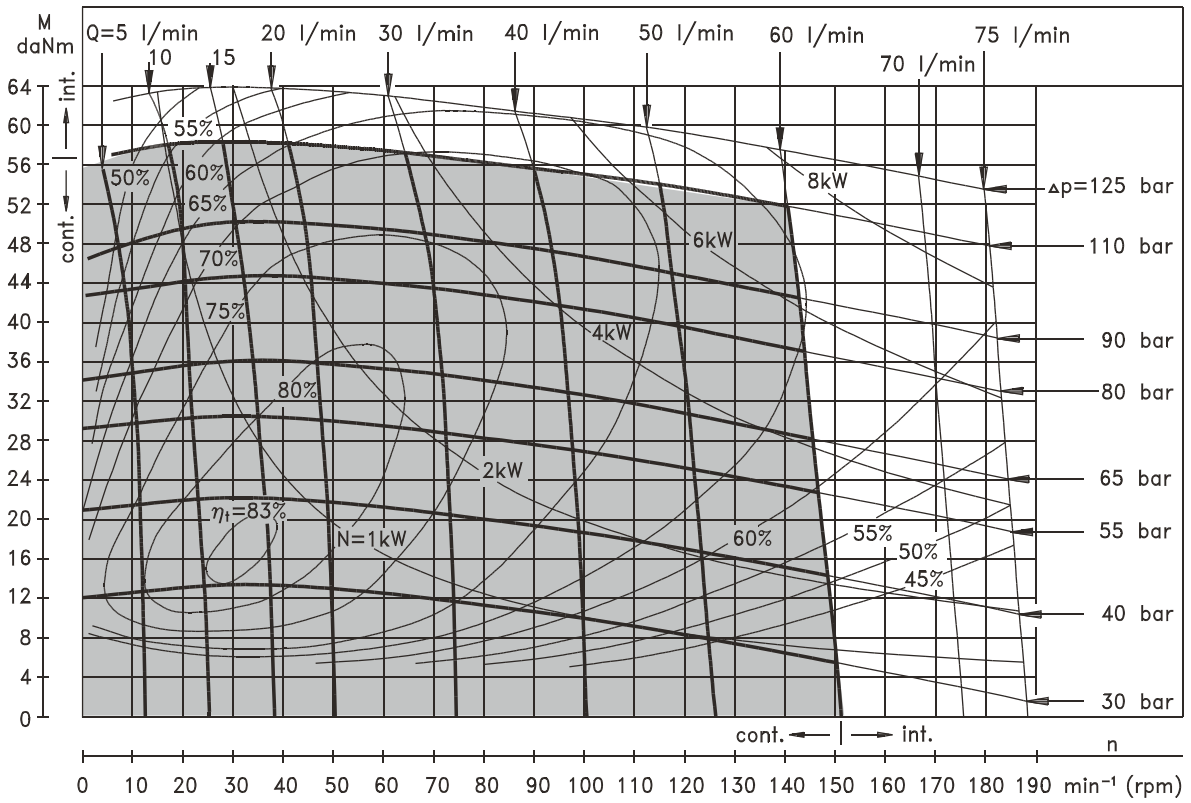

The function diagram data was collected at back pressure 5 ÷ 10 bar and oil with viscosity of 32 mm<sup>2</sup>/s at 50° C.

## DIMENSIONS AND MOUNTING DATA

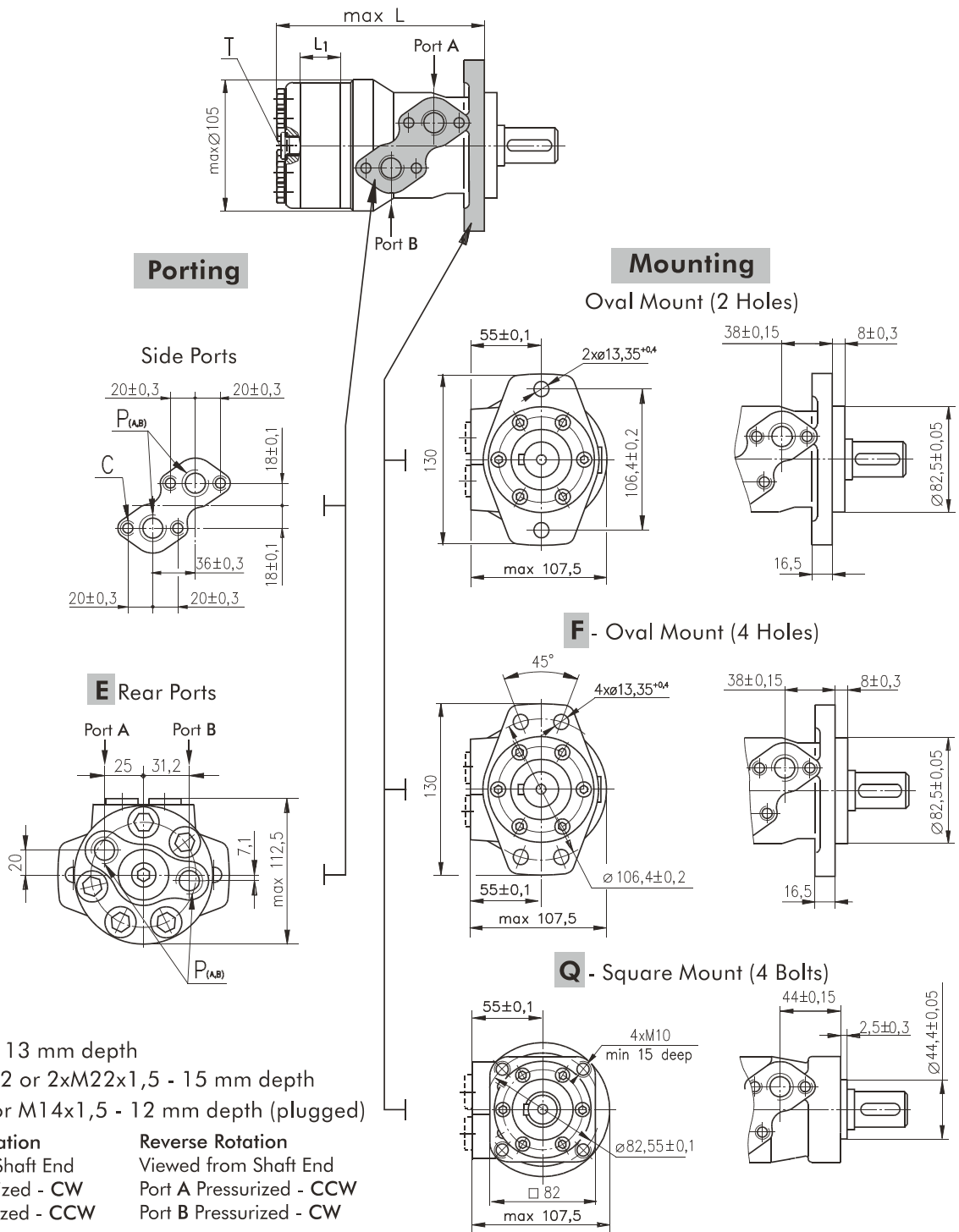

- C** : 4xM8 - 13 mm depth  
**P<sub>(A,B)</sub>** : 2xG1/2 or 2xM22x1,5 - 15 mm depth  
**T** : G1/4 or M14x1,5 - 12 mm depth (plugged)

**Standard Rotation**  
 Viewed from Shaft End  
 Port A Pressurized - CW  
 Port B Pressurized - CCW

**Reverse Rotation**  
 Viewed from Shaft End  
 Port A Pressurized - CCW  
 Port B Pressurized - CW

Type	L, mm	Type	L, mm	Type	L, mm	Type	L, mm	L <sub>1</sub> , mm
MR(F) 50	138,0	MRQ 50	143,5	MR(F)E 50	157,5	MRQE 50	163,5	9,0
MR(F) 80	143,0	MRQ 80	148,5	MR(F)E 80	162,5	MRQE 80	168,5	14,0
MR(F) 100	146,0	MRQ 100	152,0	MR(F)E 100	165,5	MRQE 100	171,5	17,4
MR(F) 125	150,5	MRQ 125	156,5	MR(F)E 125	170,0	MRQE 125	176,0	21,8
MR(F) 160	156,5	MRQ 160	162,5	MR(F)E 160	176,0	MRQE 160	182,0	27,8
MR(F) 200	163,5	MRQ 200	169,5	MR(F)E 200	183,0	MRQE 200	189,0	34,8
MR(F) 250	172,0	MRQ 250	179,0	MR(F)E 250	192,0	MRQE 250	198,0	43,5
MR(F) 315	183,0	MRQ 315	189,0	MR(F)E 315	204,0	MRQE 315	210,0	54,8
MR(F) 400	198,0	MRQ 400	204,0	MR(F)E 400	218,0	MRQE 400	224,0	69,4



## ORDER CODE

	1	2	3	4	5	6	7	8	9	10
<b>M R</b>										

### Pos.1 - Mounting Flange

- omit - Oval mount, two holes
- F** - Oval mount, four holes
- Q** - Square mount, four bolts

### Pos.2 - Option (needle bearings)

- omit - none
- N** - with needle bearings

### Pos.3 - Port type

- omit - Side ports
- E** - Rear ports

### Pos.4 - Displacement code

- 50** - 51,5 [cm<sup>3</sup>/rev]
- 80** - 80,3 [cm<sup>3</sup>/rev]
- 100** - 99,8 [cm<sup>3</sup>/rev]
- 125** - 125,7 [cm<sup>3</sup>/rev]
- 160** - 159,6 [cm<sup>3</sup>/rev]
- 200** - 199,8 [cm<sup>3</sup>/rev]
- 250** - 250,1 [cm<sup>3</sup>/rev]
- 315** - 315,7 [cm<sup>3</sup>/rev]
- 400** - 397,0 [cm<sup>3</sup>/rev]

### Pos.5 - Shaft Extensions\*(see page 24)

- C** - ø25 straight, Parallel key A8x7x32 DIN6885
- VC** - ø25 straight, Parallel key A8x7x32 DIN6885 with corrosion resistant bushing
- CO** - ø1" straight, Parallel key 1/4"x1/4"x1 1/4" BS46
- VCO** - ø1" straight, Parallel key 1/4"x1/4"x1 1/4" BS46 with corrosion resistant bushing
- SH** - ø25,32 splined BS 2059 (SAE 6B)
- VSH** - ø25,32 splined BS 2059 (SAE 6B) with corrosion resistant bushing
- K** - ø28,56 tapered 1:10, Parallel key B5x5x14 DIN6885
- SA** - ø24,5 splined B 25x22 DIN 5482
- VSA** - ø24,5 splined B 25x22 DIN 5482 with corrosion resistant bushing

- CB** - ø32 straight, Parallel key A10x8x45 DIN6885
- KB** - ø35 tapered 1:10, Parallel key B6x6x20 DIN6885
- SB** - splined A 25x22 DIN 5482
- OB** - ø1 1/4" tapered 1:8, Parallel key 5/16"x5/16"x1 1/4" BS46
- HB** - ø1 1/4" splined 14T ANSI B92.1 - 1976

### Pos. 6 - Shaft Seal Version (see page 26)

- omit - Low pressure shaft seal or Standard shaft seal for "...B" shaft
- D** - Standard shaft seal
- U** - High pressure shaft seal (without check valves)

### Pos. 7 - Drain Port

- omit - with drain port
- 1** - without drain port

### Pos. 8 - Ports

- omit - BSPP (ISO 228)
- M** - Metric (ISO 262)

### Pos. 9 - Special Features (see page 46)

### Pos.10 - Design Series

- omit - Factory specified

\* The permissible output torque for shafts must not be exceeded!

**NOTES:**1. The following combinations are not allowed:- **Q** flange with "...B" shafts;  
 - **N** option with "...B" shafts, Low Pressure Seal or **U** option;  
 - "...B" shafts with **D** and **U** shaft seals.

The hydraulic motors are mangano-phosphatized as standard.