



Bulletin HY30-5501-M1/UK

# Service Manual Series F1/T1

Effective: June, 2018  
Supersedes: December, 2016

---



<b>List of contents</b>	<b>Page</b>
New attributes on F1/T1 .....	3
Specifications, design and function .....	4
Check of shaft seal .....	5
Checking the flow from the pump .....	6
Checking performance of the motor .....	7
Direction of rotation .....	8
Disassembling .....	9
Assembling .....	10
Split view / spare parts .....	11
Split view / spare parts (motor) .....	12
Spare part kits and tools .....	13

Conversion factors	
1 kg	= 2.2046 lb
1 N	= 0.22481 lbf
1 bar	= 14.504 psi
1 l	= 0.21997 UK gallon
1 l	= 0.26417 US gallon
1 cm <sup>3</sup>	= 0.061024 in <sup>3</sup>
1 m	= 3.2808 feet
1 mm	= 0.03937 in
1 °C	= 1.8°F + 32



## WARNING

FAILURE OR IMPROPER SELECTION OR IMPROPER USE OF THE PRODUCTS AND/OR SYSTEMS DESCRIBED HEREIN OR RELATED ITEMS CAN CAUSE DEATH, PERSONAL INJURY AND PROPERTY DAMAGE.

This document and other information from Parker Hannifin Corporation, its subsidiaries and authorized distributors provide product and/or system options for further investigation by users having technical expertise. It is important that you analyze all aspects of your application, including consequences of any failure, and review the information concerning the product or system in the current product catalogue. Due to the variety of operating conditions and applications for these products or systems, the user, through its own analysis and testing, is solely responsible for making the final selection of the products and systems and assuring that all performance, safety and warning requirements of the application are met.

The products described herein, including without limitation, product features, specifications, designs, availability and pricing, are subject to change by Parker Hannifin Corporation and its subsidiaries at any time without notice.

## Offer of Sale

Please contact your Parker representation for a detailed "Offer of Sale".

# F1/T1

The F1/T1 series offers many additional values for operators of cargo cranes, container lifts, skip loaders, forest cranes, concrete mixers and similar truck applications.

Series F1/T1 is a very efficient and straight forward pump design with unsurpassed reliability. Its small envelope size makes for a simple and inexpensive installation requiring a minimum of piping.

### New features of the F1/T1 are:

- Higher selfpriming speeds
- Max operating pressure 400 bar
- New frame sizes to meet market requirements
- Higher overall efficiency
- Increased reliability
- Reduced noise level
- Possible leakage paths reduced
- Easier to change direction of rotation
- Smaller installation dimensions

... thanks to:

- 45° bent-axis angle
- Optimal inlet port geometry
- New ball and roller bearings
- Single housing design

### All of this in addition to previous features:

- Spherical pistons - high speeds
- Laminated piston rings - low leakage
- Positive synchronization with timing gear
- Installation above the reservoir level possible
- Tolerates low temperatures and high temperature shocks
- Shaft end and mounting flange meet the ISO standard



F1-25/-41/-51/-61.



F1-81/-101.

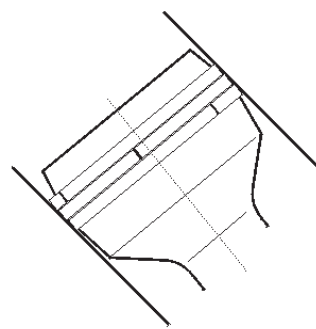

F1 piston with piston rings.

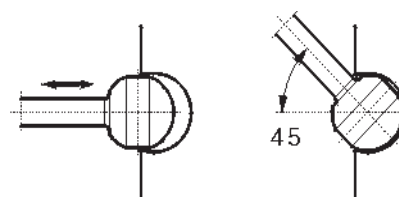

F1 piston-to-shaft locking.

F1 frame size	25	41	51	61	81	101
<b>Displacement</b> [cm <sup>3</sup> /rev]	25,6	40,9	51,1	59,5	81,6	102,9
<b>Max flow</b> <sup>1)</sup> [l/min]						
at 350 bar	67	98	112	131	163 <sup>2)</sup>	185 <sup>2)</sup>
at 400 bar	56	86	97	113	143	160
<b>Max operating pressure</b> [bar]						
continuous	350					350
intermittent	400					400
<b>Shaft speed</b> [rpm]						
- short circuited pump (low press.)	2700	2700	2700	2700	2300	2300
- max speed at 350 bar <sup>1)</sup>	2600	2400	2200	2200	2000 <sup>2)</sup>	1800 <sup>2)</sup>
at 400 bar <sup>1)</sup>	2200	2100	1900	1900	1750	1550 <sup>2)</sup>
<b>Torque</b> [Nm]						
at 350 bar	142	227	284	331	453	572
at 400 bar	163	260	324	378	518	653
<b>Input power</b> [kW]						
- intermittent	39	57	66	76	95	108
- continuous	31	46	52	61	76	86
<b>Weight</b> [kg]	8.5	8.5	8.5	8.5	12.5	12.5

1) Valid at an inlet pressure of 1.0 bar (abs.) when operating on mineral oil at a viscosity of 30 mm<sup>2</sup>/s (cSt).

2) Valid with 2 1/2" inlet (suction) line.  
With 2" suction line: F1-81 – max 1800 rpm (Q<sup>3</sup>140 l/min);  
F1-101 – max 1400 rpm (Q<sup>3</sup>140 l/min).

### Pump cross section

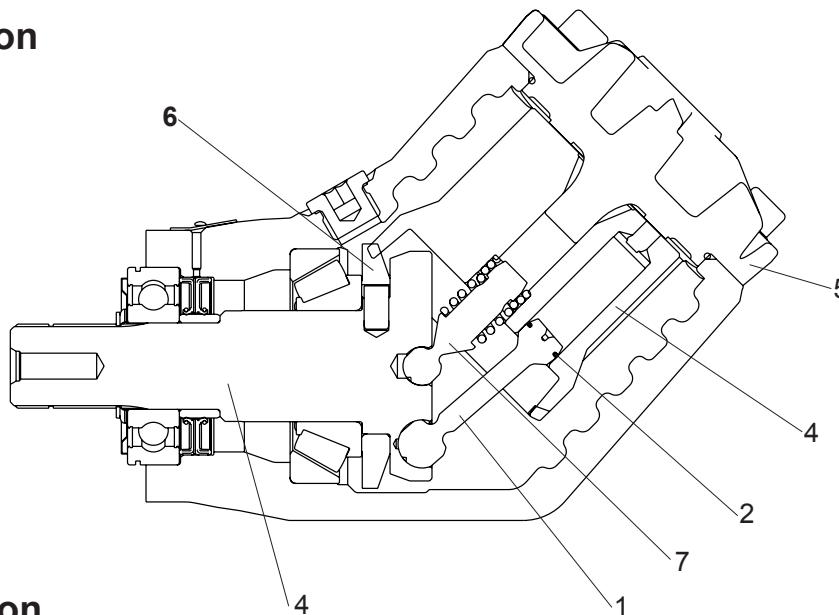

### Design and function

F1 is a piston pump with spherical pistons (1) including piston rings (2). The pistons are working at the angle of 45° to the shaft (3). When the shaft rotates, the pistons move up and down in the cylinder barrel (4), forcing the oil to pass from the inlet port to the outlet in the end cap (5). A ring gear (6) connects the cylinder barrel to the drive shaft, causing these to rotate at the same speed.

A barrel support (7) with spring presses the cylinder barrel against the end cap. An internal connection from the housing to the suction ports eliminates a separate drain line to the tank. F1 is provided with shaft and connection flange that fits direct to PTO's with ZF standard.

## Check of Shaft Seal and seal towards PTO

The shaft seal, seals towards the hydraulic oil in the barrel housing and towards the oil in the PTO. The ball bearing is also protected with a protective washer, assembled outside the ball bearing.

If there is a leakage either from the PTO or from the barrel housing, the oil will come out through the indication hole.

Check that no oil is dripping out of the indication hole, when the pump is in operation. If there is a leakage from the shaft seal, it must be exchanged.

Indication hole is placed under the protection cover.

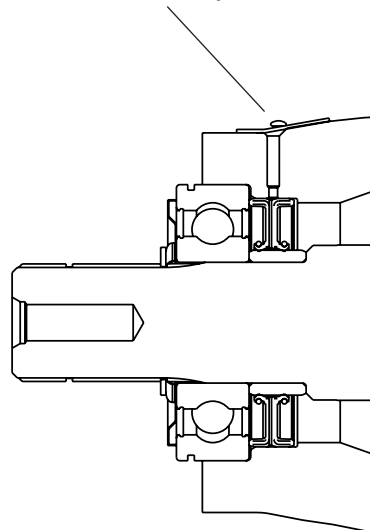

**Note:** A heavy leakage can be caused by a worn-out pump, whereby high pressure oil will come out into the housing in such large quantities that the seal ring might be damaged. If there is a steady stream of oil from the indication hole, the pump is probably damaged and will have to be replaced or repaired.

## Checking the flow from the pump

The flow from the pump can be checked by means of a test instrument comprising a flowmeter and a relief valve.

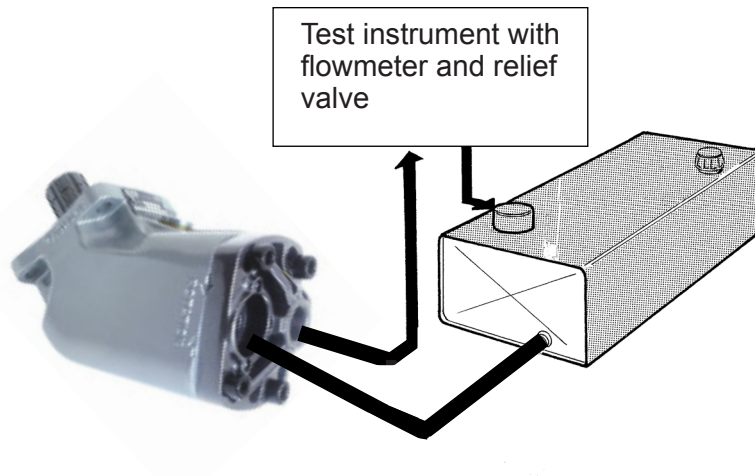

When the pump is running at about 800 - 1400 rpm and is loaded up to 150 - 200 bar, the flow must not decrease by more than 10%.

Example: An F01-041 running at 1225 rpm gives - according to the flowmeter - a flow of 48 l / min. If the pump is loaded, the flow must not decrease by more than  $0,1 * 48 = 4,8$  l / min, i.e. the flowmeter should indicated at least  $48 - 4,8 = 43,2$  l / min. If the flow decrease more than 4,8 l / min the pump is damaged and have to be replaced or repaired.

The table below shows minimum flow at 1000 rpm and 150 - 200 bar pressure.

Size	Rpm	Min. flow (l/min)
F01-025	1000	21,6
F01-041	1000	34,2
F01-051	1000	44,1
F01-061	1000	54,9
F01-081	1000	72,0
F01-101	1000	88,2

### Checking the performance of F1 motor

The general condition of the unit can be established by checking the drain flow. Remove the drain line and keep the drain port above a suitable container. Run the unit at normal speed and pressurize the system to 150 bar (2000 psi). Measure the drain flow for one minute; if it exceeds the maximum figures shown below, the unit is worn or damaged internally and should be replaced or repaired. Also, check for leakage at the shaft seal and between end cap and barrel housing.

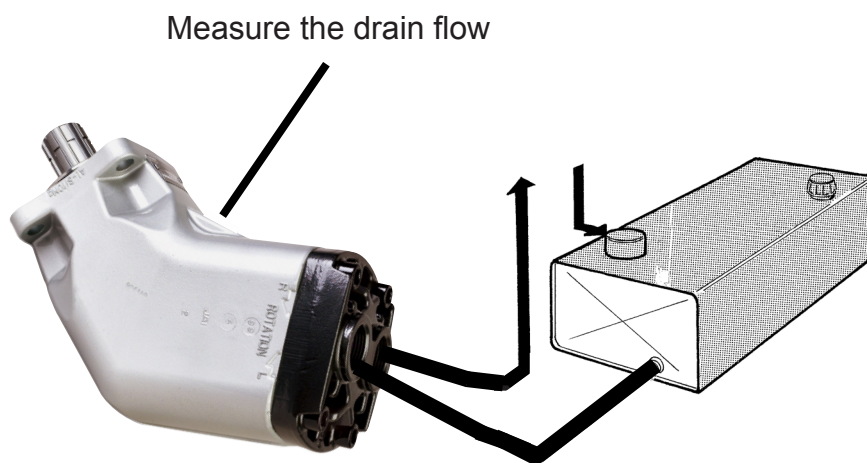

The table below shows maximum leakage at 150 bar (2000 psi) pressure.

Size	Pressure (bar)	Max (l/min)
F01-025-M	150	2.0
F01-041-M	150	2.5
F01-051-M	150	2.5
F01-061-M	150	2.5
F01-081-M	150	3.0
F01-101-M	150	3.0
F01-121-M	150	3.0

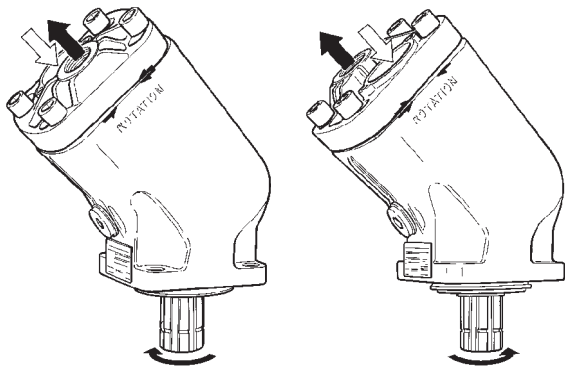

Left hand rotation      Right hand rotation

**Direction of rotation**

The factory assembled direction of rotation, appears on the label and by arrows on the material. (R=Right L=Left)

The pictures above show direction of flow vs. shaft rotation. The direction of rotation can be changed (i.e. from right hand to left hand) by turning the end cap.

Remove the four cap screws and turn the end cap about half a turn while making sure it stays in contact with the barrel housing. Re-fit the cap screws and torque to  $90 \pm 10$  Nm.

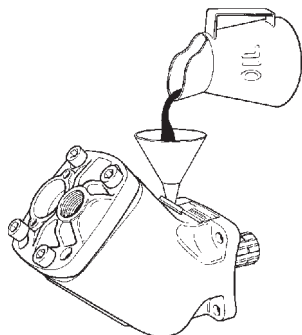

**Before start-up, the housing must be filled with hydraulic fluid.**

**Start-up**

Make sure the entire hydraulic system is clean before filling it with a recommended hydraulic fluid.

In particular, make sure the pump is filled (to at least 50%) by connecting the suction hose and undo the hexagon plug until oil appears. Torque the hexagon plug to  $30 \pm 5$  Nm.

**Disassembling**

1. Fasten the barrel housing in a vice with the shaft upwards.

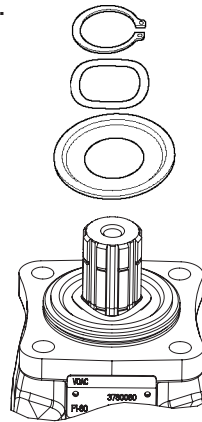

2. Disassemble the retaining ring (item 465), the waved spring washer (item 238) and the protective washer (item 236).

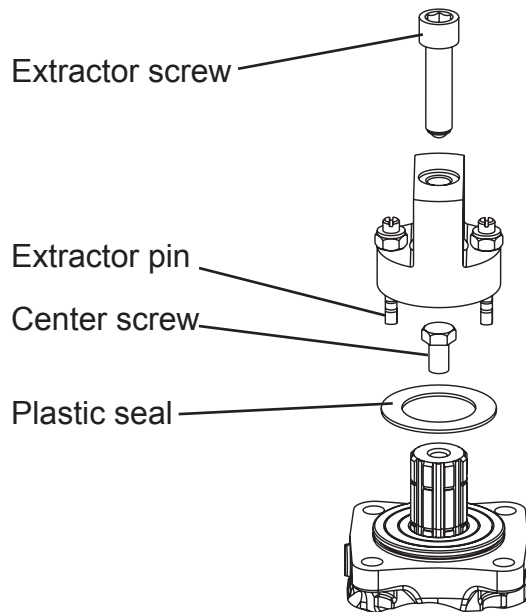

3. Disassemble the plastic seal fitted on the roller bearing and fasten the center screw a couple of turns. Take the mandrel which comes with the disassembling,- reassembling tool and deform the ball cage until it is possible to turn the mandrel  $90^\circ$ , down in the ball cage. Place the tool over the shaft end with the extractor pins inserted in the bearing. Turn the extractor pins  $90^\circ$  and screw the extractor screw down until the bearing comes loose. Remove the O-ring which is fitted under the bearing.



Only on the prototypes!

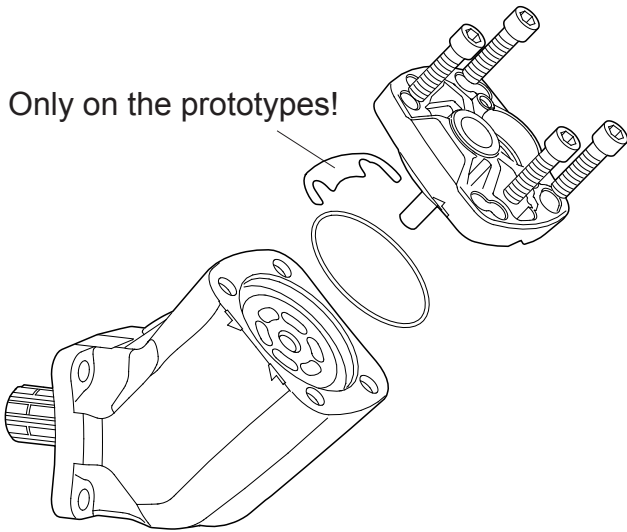

4.  
Disassemble the end cap.

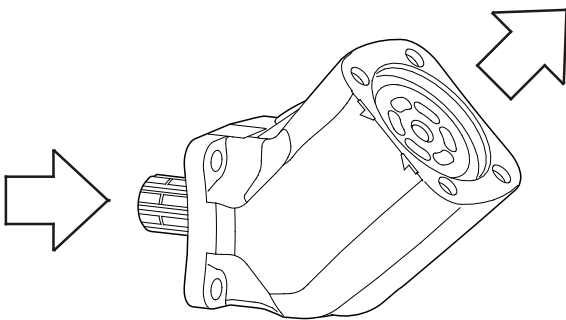

5.  
Take out the shaft, the pistons, the barrel support and the cylinder barrel from the barrel housing. Disassemble the cassette seal from the barrel housing.

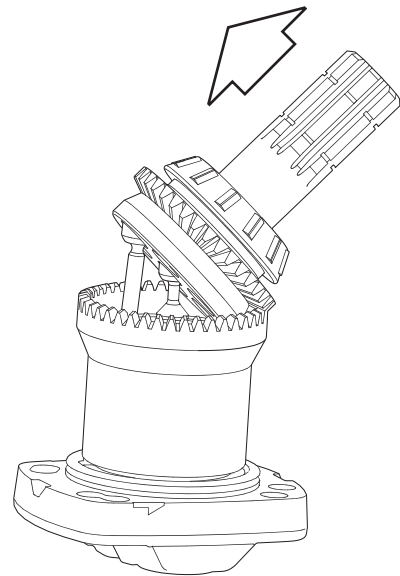

6.  
Angle the shaft up and disassemble it together with pistons and barrel support. The barrel support is kept in position in the barrel with a snap function.

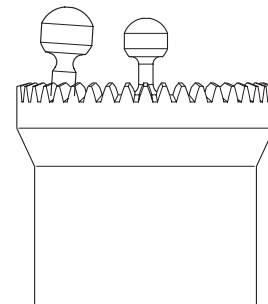
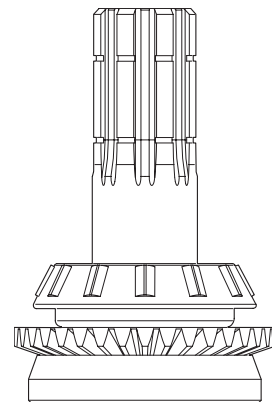

**Assembling**

1. Fasten the end cap in a vice with the center shaft upwards.

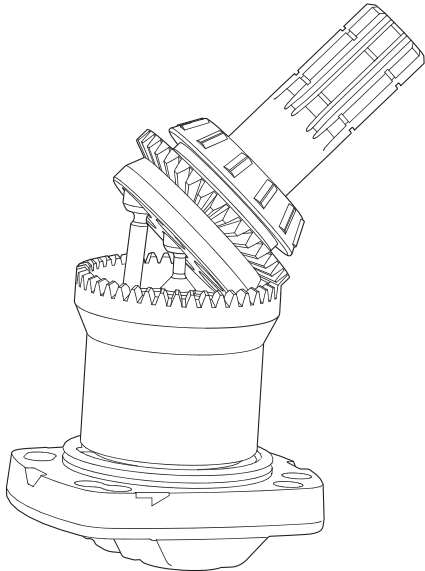

2. Place the pistons and the barrel support in the cylinder barrel. Place the shaft over the pistons and on the barrel support. Turn the package 180° and shake down the pistons into the piston holes in the shaft, then angle 45°. Turn the package back and reassemble the cylinder barrel on the end cap. Ensure correct timing. (Marking, punch mark)

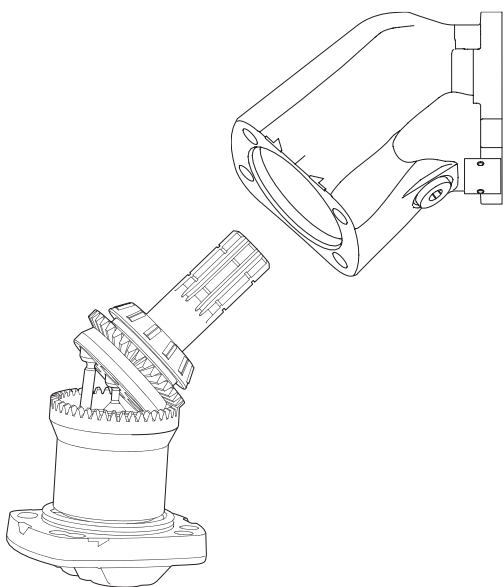

3. Reassemble the barrel housing. Ensure correct rotation. Tighten at least two screws. Check the timing by rotating the shaft. The timing is easy to check under the purge plug in the housing.

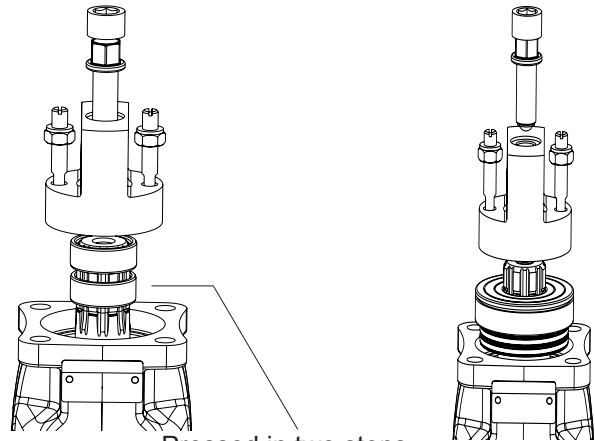

4. Fasten the package in a vice with the shaft end upwards. Place the inner ring on to the shaft. The inner ring is pressed down in two steps. First step with the assemble tool alone. Second step with assemble tool together with the distance ring to reach final position for the inner ring. Lubricate the outer diameter of the cassette seal with hydraulic oil. Place the cassette seal together with the bearing on to the shaft. Take the assembly tool and place it on the bearing. Fasten the assembly screw a couple of turns. Pull down the bearing together with cassette seal by turning the nut as far as possible. Reassemble the protective washer (item 465), the waved spring washer (item 238) and the retaining ring (item 465) if necessary (see publ. 1780). Fasten all screws and make sure that correct torque is achieved. (90±10Nm)

Turn the shaft at least on rev. to ensure correct mounting.

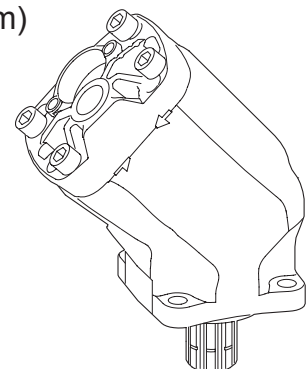

**Splitview / Spare Parts**

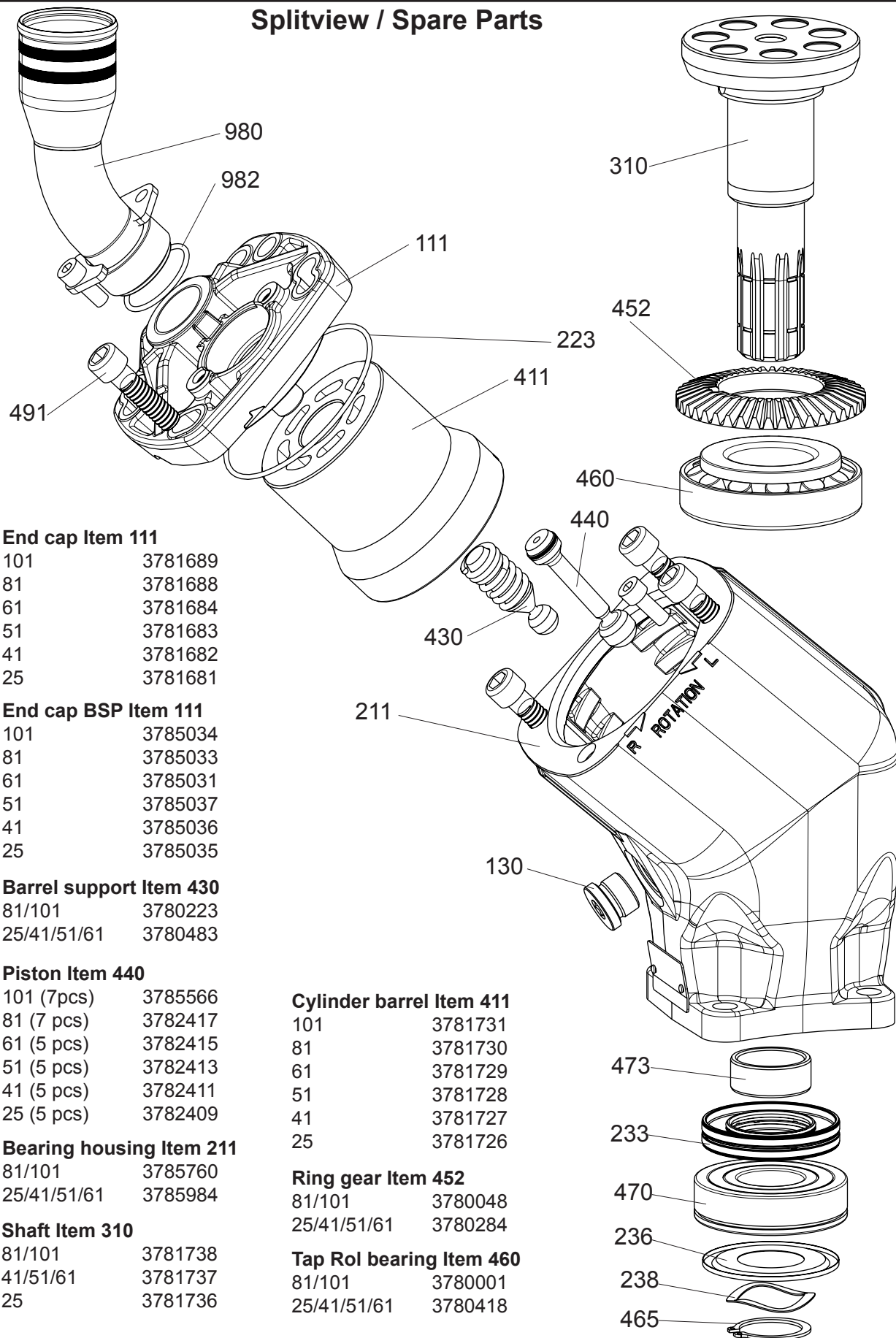

**End cap Item 111**

101	3781689
81	3781688
61	3781684
51	3781683
41	3781682
25	3781681

**End cap BSP Item 111**

101	3785034
81	3785033
61	3785031
51	3785037
41	3785036
25	3785035

**Barrel support Item 430**

81/101	3780223
25/41/51/61	3780483

**Piston Item 440**

101 (7pcs)	3785566
81 (7 pcs)	3782417
61 (5 pcs)	3782415
51 (5 pcs)	3782413
41 (5 pcs)	3782411
25 (5 pcs)	3782409

**Bearing housing Item 211**

81/101	3785760
25/41/51/61	3785984

**Shaft Item 310**

81/101	3781738
41/51/61	3781737
25	3781736

**Cylinder barrel Item 411**

101	3781731
81	3781730
61	3781729
51	3781728
41	3781727
25	3781726

**Ring gear Item 452**

81/101	3780048
25/41/51/61	3780284

**Tap Rol bearing Item 460**

81/101	3780001
25/41/51/61	3780418

Splitview / Spare Parts F1 Motor

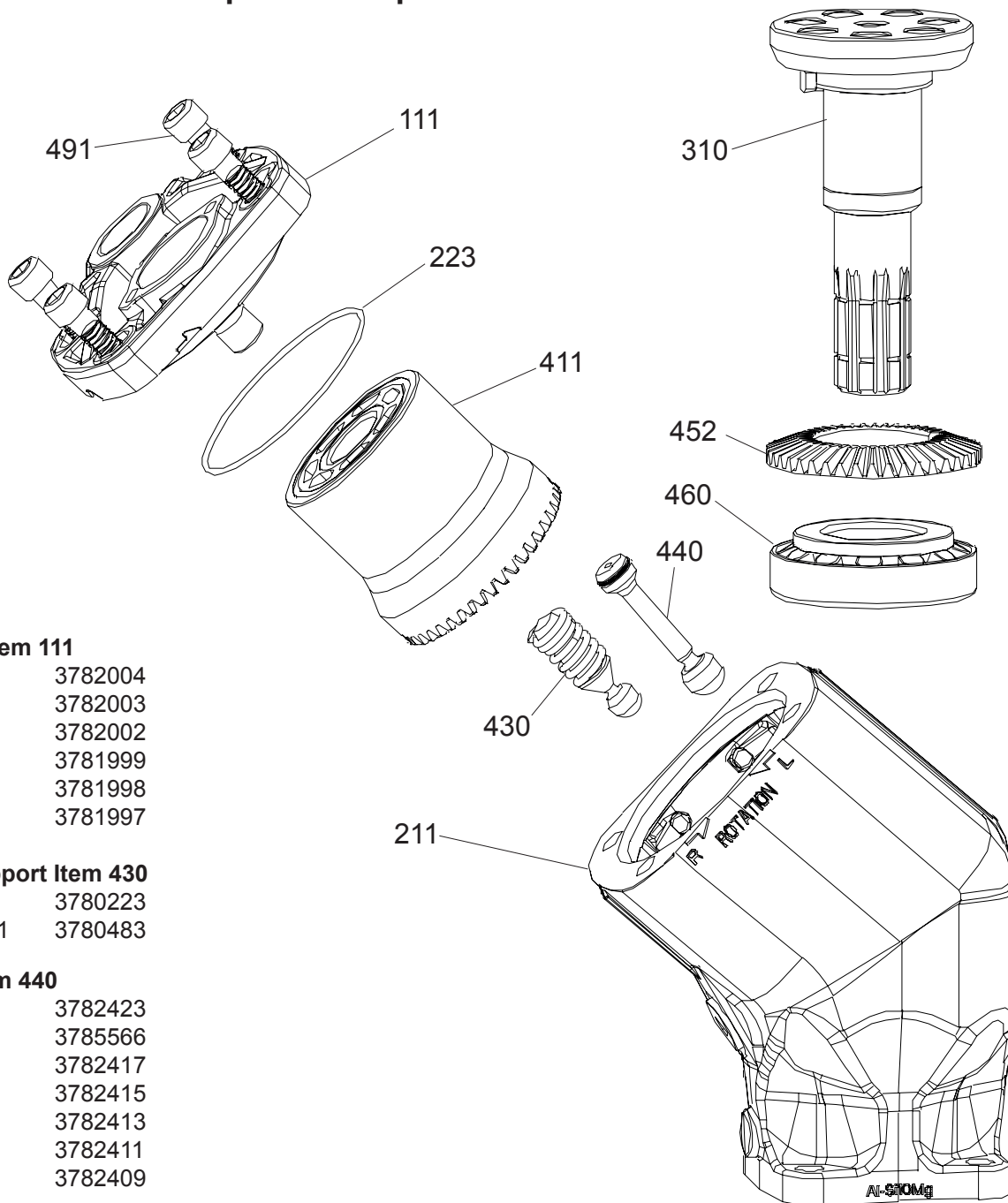

**End cap Item 111**

101	3782004
81	3782003
61	3782002
51	3781999
41	3781998
25	3781997

**Barrel support Item 430**

81/101/121	3780223
25/41/51/61	3780483

**Piston Item 440**

121	3782423
101	3785566
81	3782417
61	3782415
51	3782413
41	3782411
25	3782409

**Bearing housing Item 211**

81/101/121	3785791
25/41/51/61	3785640

**Cylinder barrel Item 411**

121	3781986
101	3781731
81	3781730
61	3781729
51	3781728
41	3781727
25	3781726

**Shaft Item 310**

81/101/121	3781738
41/51/61	3781737
25	3781736

**Ring gear Item 452**

81/101/121	3780048
25/41/51/61	3780284

**Tap Rol bearing Item 460**

81/101/121	3780001
25/41/51/61	3780418

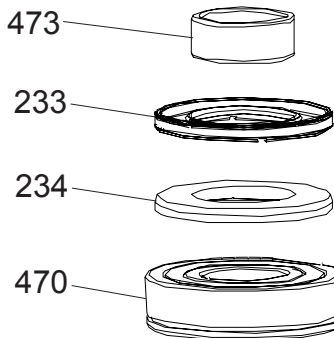

## Spare Part Kits and Tools

### Seal kit

Unit	Part no.
F1 and T1 Pump	3780862
F1 Motor	3786997

Items included:  
130, 223, 233, (234 motor), 236,  
238, 465, 470, 473, 982.

### Spare part kit (F1 Pump)

Unit	Part no.
F1-25	3781844
F1-41	3781845
F1-51	3781846
F1-61	3781847
F1-81	3781848
F1-101	3781849

Items included:  
111, 130, 223, 233, 236, 238, 411,  
430, 440, 465, 470, 473, 982.

### Spare Part Kit (T1 pump)

Unit	Part no.
T1-81	3782807
T1-121	3782808

Items included:  
111, 130, 223, 233, 236, 238, 411,  
430, 440, 465, 470, 473, 982.

### Assembly kit

Unit	Part no.
F1 and T1 Pump	3781725

Item included:  
236, 238, 465

### Parts Specification

Item	Description
111	End Cap
130	Hex Socket Plug
211	Bearing Housing
223	O-ring
227	O-ring
228	Gasket
233	Shaft Seal
234	Back-Up Ring (motor)
236	Protective Washer
238	Waved Spring Washer
241	Gasket
310	Shaft
411	Cylinder Barrel
430	Barrel Support
440	Piston
452	Ring Gear
460	Tapped Roller Bearing
465	Retaining Ring
470	Roller Bearing
473	Inner Ring
491	Hex Socket Screw
980	Suction Fitting
982	O-ring

### Exchange Units

Unit	Part no.
F1-25	3780856
F1-41	3780857
F1-51	3780858
F1-61	3780859
F1-81	3780860
F1-101	3780861

**Note!** Not on all markets.

### Dis- and re-assembling tool

Detail	Part no.
F1, T1, F1 motor	3780917



Parker Hannifin  
Pump and Motor Division  
Flygmotorvägen 2  
SE-461 82 Trollhättan  
Sweden  
Tel: +46 (0)520 40 45 00  
Fax: +46 (0)520 371 05  
[www.parker.com](http://www.parker.com)