

Summary: Displacements - Pressures - Speeds

	Type	Displacement	Max. Pressure	Min speed	Max speed
XV-0P	XV-0P/0.17	0.16 cm ³ /rev	260 bar	700 rpm	9000 rpm
	XV-0P/0.25	0.24 cm ³ /rev	260 bar	700 rpm	9000 rpm
	XV-0P/0.45	0.45 cm ³ /rev	280 bar	700 rpm	9000 rpm
	XV-0P/0.57	0.56 cm ³ /rev	280 bar	700 rpm	9000 rpm
	XV-0P/0.76	0.75 cm ³ /rev	280 bar	700 rpm	9000 rpm
	XV-0P/0.98	0.92 cm ³ /rev	280 bar	700 rpm	6000 rpm
	XV-0P/1.27	1.26 cm ³ /rev	280 bar	700 rpm	6000 rpm
	XV-0P/1.52	1.48 cm ³ /rev	280 bar	700 rpm	6000 rpm
	XV-0P/2.30	2.28 cm ³ /rev	210 bar	700 rpm	5000 rpm
XV-1P	XV-1P/0.9	0.91 cm ³ /rev	280 bar	700 rpm	6000 rpm
	XV-1P/1.2	1.17 cm ³ /rev	290 bar	700 rpm	6000 rpm
	XV-1P/1.7	1.56 cm ³ /rev	290 bar	700 rpm	6000 rpm
	XV-1P/2.2	2.08 cm ³ /rev	290 bar	700 rpm	6000 rpm
	XV-1P/2.6	2.60 cm ³ /rev	300 bar	700 rpm	6000 rpm
	XV-1P/3.2	3.12 cm ³ /rev	300 bar	700 rpm	6000 rpm
	XV-1P/3.8	3.64 cm ³ /rev	300 bar	700 rpm	6000 rpm
	XV-1P/4.3	4.16 cm ³ /rev	300 bar	700 rpm	6000 rpm
	XV-1P/4.9	4.94 cm ³ /rev	300 bar	700 rpm	6000 rpm
	XV-1P/5.9	5.85 cm ³ /rev	300 bar	700 rpm	5000 rpm
	XV-1P/6.5	6.50 cm ³ /rev	300 bar	700 rpm	5000 rpm
XV-2P	XV-1P/7.8	7.54 cm ³ /rev	260 bar	700 rpm	5000 rpm
	XV-1P/9.8	9.88 cm ³ /rev	230 bar	700 rpm	4000 rpm
	XV-2P/4	4.2 cm ³ /rev	300 bar	700 rpm	3500 rpm
	XV-2P/6	6.0 cm ³ /rev	300 bar	700 rpm	3500 rpm
	XV-2P/9	8.4 cm ³ /rev	300 bar	700 rpm	3500 rpm
	XV-2P/11	10.8 cm ³ /rev	300 bar	700 rpm	3500 rpm
	XV-2P/14	14.4 cm ³ /rev	290 bar	700 rpm	3500 rpm
	XV-2P/17	16.8 cm ³ /rev	270 bar	700 rpm	3500 rpm
	XV-2P/19	19.2 cm ³ /rev	250 bar	700 rpm	3000 rpm
	XV-2P/22	22.8 cm ³ /rev	240 bar	700 rpm	3000 rpm
	XV-2P/26	26.2 cm ³ /rev	210 bar	700 rpm	3000 rpm
XV-3P	XV-2P/30	30.0 cm ³ /rev	200 bar	700 rpm	2500 rpm
	XV-2P/34	34.2 cm ³ /rev	190 bar	700 rpm	2500 rpm
	XV-2P/40	39.6 cm ³ /rev	180 bar	700 rpm	2000 rpm
	XV-3P/15	14.89 cm ³ /rev	320 bar	700 rpm	3000 rpm
	XV-3P/18	17.37 cm ³ /rev	320 bar	700 rpm	3000 rpm
	XV-3P/21	21.10 cm ³ /rev	300 bar	700 rpm	3000 rpm
	XV-3P/27	26.97 cm ³ /rev	270 bar	700 rpm	3000 rpm
	XV-3P/32	32.27 cm ³ /rev	270 bar	700 rpm	3000 rpm
	XV-3P/38	38.47 cm ³ /rev	270 bar	700 rpm	2800 rpm
	XV-3P/43	43.44 cm ³ /rev	250 bar	700 rpm	2800 rpm
	XV-3P/47	47.16 cm ³ /rev	250 bar	700 rpm	2800 rpm
	XV-3P/51	50.88 cm ³ /rev	250 bar	700 rpm	2800 rpm
	XV-3P/54	54.60 cm ³ /rev	250 bar	700 rpm	2300 rpm
	XV-3P/61	60.81 cm ³ /rev	220 bar	700 rpm	2300 rpm
XV-3P/64	64.53 cm ³ /rev	220 bar	700 rpm	2300 rpm	
XV-3P/70	70.74 cm ³ /rev	210 bar	700 rpm	2300 rpm	
XV-3P/74	74.46 cm ³ /rev	190 bar	700 rpm	2300 rpm	
XV-3P/90	86.87 cm ³ /rev	160 bar	700 rpm	2300 rpm	

General technical data

Type of fluid to be used	Mineral-based hydraulic oil HLP HV (D IN 51524)
Minimum operating viscosity	10 mm ² /s
Maximum operating viscosity	100 mm ² /s
Maximum admissible viscosity at start-up	1500 mm ² /s
Recommended viscosity	20 mm ² /s - 100 mm ² /s
Ambient temperature	-20 °C - 60°C
Fluid operating temperature	-15°C - 80°C
Recommended fluid operating temperature	30°C - 50° C
For temperatures above 120°C	Request FKM seals (V iton)
Max. inlet fluid suction pressure (IN)	0.02-0.08 bars
Max. inlet fluid pressure (IN)	0.3 - 0.5 bars (for higher pressures consult the manufacturer)
Inlet fluid filtering (IN)	30 - 60 Microns
Outlet fluid filtering (OUT)	10 - 25 Microns
Max. inlet fluid speed (IN)	0.5 - 1.5 m/s
Max. outlet fluid speed (OUT)	3.0 - 5.5m/s
Use of water-glycol (HF-C)	max n. of revolutions 1100 rpm; max pressure 170 bars

Flow rate tables

TYPE	cm3/ rev	Flow rate l/min	rpm														Flow rate l/min		
			700	1000	1500	2000	2500	3000	3500	4000	4500	5000	5500	6000	7000	8000		9000	
XV 0P/0.17	0,16	Flow rate l/min	0,106	0,152	0,228	0,304	0,380	0,456	0,532	0,608	0,684	0,760	0,836	0,912	1,064	1,216	1,368	Flow rate l/min	
XV 0P/0.25	0,24		0,160	0,228	0,342	0,456	0,570	0,684	0,798	0,912	1,026	1,140	1,254	1,368	1,596	1,824	2,052		
XV 0P/0.45	0,45		0,299	0,428	0,641	0,855	1,069	1,283	1,496	1,710	1,924	2,138	2,351	2,565	2,993	3,420	3,848		
XV 0P/0.57	0,56		0,372	0,532	0,798	1,064	1,330	1,596	1,862	2,128	2,394	2,660	2,926	3,192	3,724	4,256	4,788		
XV 0P/0.76	0,75		0,499	0,713	1,069	1,425	1,781	2,138	2,494	2,850	3,206	3,563	3,919	4,275	4,988	5,700	6,413		
XV 0P/0.98	0,92		0,612	0,874	1,311	1,748	2,185	2,622	3,059	3,496	3,933	4,370	4,807	5,244					
XV 0P/1.27	1,26		0,838	1,197	1,796	2,394	2,993	3,591	4,190	4,788	5,387	5,985	6,584	7,182					
XV 0P/1.52	1,48		0,984	1,406	2,109	2,812	3,515	4,218	4,921	5,624	6,327	7,030	7,733	8,436					
XV 0P/2.30	2,28		1,516	2,166	3,249	4,332	5,415	6,498	7,581	8,664	9,747	10,830							

TYPE	cm3/ rev	Flow rate l/min	rpm											Flow rate l/min	
			700	1000	1500	2000	2500	3000	3500	4000	4500	5000	5500		6000
XV 1P/0.9	0,91	Flow rate l/min	0,630	0,900	1,350	1,800	2,250	2,700	3,150	3,600	4,050	4,500	4,950	5,400	Flow rate l/min
XV 1P/1.2	1,17		0,840	1,200	1,800	2,400	3,000	3,600	4,200	4,800	5,400	6,000	6,600	7,200	
XV 1P/1.7	1,56		1,190	1,700	2,550	3,400	4,250	5,100	5,950	6,800	7,650	8,500	9,350	10,200	
XV 1P/2.2	2,08		1,540	2,200	3,300	4,400	5,500	6,600	7,700	8,800	9,900	11,000	12,100	13,200	
XV 1P/2.6	2,6		1,820	2,600	3,900	5,200	6,500	7,800	9,100	10,400	11,700	13,000	14,300	15,600	
XV 1P/3.2	3,12		2,240	3,200	4,800	6,400	8,000	9,600	11,200	12,800	14,400	16,000	17,600	19,200	
XV 1P/3.8	3,64		2,660	3,800	5,700	7,600	9,500	11,400	13,300	15,200	17,100	19,000	20,900	22,800	
XV 1P/4.3	4,16		3,010	4,300	6,450	8,600	10,750	12,900	15,050	17,200	19,350	21,500	23,650	25,800	
XV 1P/4.9	4,94		3,430	4,900	7,350	9,800	12,250	14,700	17,150	19,600	22,050	24,500	26,950	29,400	
XV 1P/5.9	5,85		4,130	5,900	8,850	11,800	14,750	17,700	20,650	23,600	26,550	29,500			
XV 1P/6.5	6,5		4,550	6,500	9,750	13,000	16,250	19,500	22,750	26,000	29,250	32,500			
XV 1P/7.8	7,54		5,460	7,800	11,700	15,600	19,500	23,400	27,300	31,200	35,100	39,000			
XV 1P/9.8	9,88		6,860	9,800	14,700	19,600	24,500	29,400	34,300	39,200					

TYPE	cm3/rev		rpm							
			700	1000	1500	2000	2500	3000		3500
XV 2P/4	4,2	Flow rate l/min	2,800	4,000	6,000	8,000	10,000	12,000	14,000	Flow rate l/min
XV 2P/6	6		4,200	6,000	9,000	12,000	15,000	18,000	21,000	
XV 2P/9	8,4		6,300	9,000	13,500	18,000	22,500	27,000	31,500	
XV 2P/11	10,8		7,700	11,000	16,500	22,000	27,500	33,000	38,500	
XV 2P/14	14,4		9,800	14,000	21,000	28,000	35,000	42,000	29,000	
XV 2P/17	16,8		11,900	17,000	25,500	34,000	42,500	51,000	59,500	
XV 2P/19	19,2		13,300	19,000	28,500	38,000	47,500	57,000		
XV 2P/22	22,8		15,400	22,000	33,000	44,000	55,000	66,000		
XV 2P/26	26,2		18,200	26,000	39,000	52,000	65,000	78,000		
XV 2P/30	30		21,000	30,000	45,000	60,000	75,000			
XV 2P/34	34,2		23,800	34,000	51,000	68,000	85,000			
XV 2P/40	39,6		28,000	40,000	60,000	80,000				

TYPE	cm3/rev		rpm							
			700	1000	1500	2000	2300	2500		3000
XV 3P/15	14,89	Flow rate l/min	9,90	14,15	21,22	28,29	32,54	35,37	42,44	Flow rate l/min
XV 3P/18	17,37		11,55	16,51	24,76	33,01	37,96	41,26	49,52	
XV 3P/21	21,10		14,03	20,04	30,06	40,08	46,10	50,11	60,13	
XV 3P/27	26,97		17,94	25,62	38,43	51,24	58,93	64,05	76,86	
XV 3P/32	32,27		21,46	30,65	45,98	61,31	70,50	76,63	91,96	
XV 3P/38	38,47		25,58	36,55	54,82	73,09	84,06	91,37		
XV 3P/43	43,44		28,88	41,26	61,89	82,53	94,91	103,16		
XV 3P/47	47,16		31,36	44,80	67,20	89,60	103,04	112,00		
XV 3P/51	50,88		33,84	48,34	72,51	96,67	111,17			
XV 3P/54	54,60		36,31	51,87	77,81	103,75	119,31			
XV 3P/61	60,81		40,44	57,77	86,65	115,54	132,87			
XV 3P/64	64,53		42,91	61,31	91,96	122,61	141,00			
XV 3P/70	70,74		47,04	67,20	100,80	134,40	154,56			
XV 3P/74	74,46		49,52	70,74	106,11	141,47	162,70			
XV 3P/90	86,87		57,77	82,53	123,79	165,05	189,81			

TORQUES ALLOWED ON SHAFT:

FORMULA FOR EVALUATING SHAFT	SHAFT [IDENTIFIER] - CODE - DESCRIPTION		T.2 [Nm]
$T.2 \leq \frac{vi \times \Delta p}{20 \times \pi \times \eta m}$ <p>T.2 = max. torque allowed by shaft [Nm]</p>	XV-0P	[A] - CI001 - Parallel ø 7 - M 7x1 - key thk sp.2	2
		[B] - CF001 - Milled shank ø 7 - sp. 5	9,2
		[F] - CF005 - Milled shank ø 7 - sp.4,5 L = 9	8
	XV-1P	[A] - CI001 - Parallel ø12 - M10x1 - key thk. 3	25,8
		[B] - CI002 - Parallel ø12.7 - key thk. 3.2 (SAE)	32,8
		[C] - CF001 - Milled shank ø10 - thk.5 ("BH" Standard German)	13,8
		[D] - CF002 - Milled shank ø10 - thk.5	13,8
		[E] - CF003 - Milled shank ø11 - thk.6.63 (SAE)	25,8
		[F] - CO001 - Tapered 1:8 - ø10 - M7x1 - key thk.2.4	43
		[G] - CO002 - Tapered 1:8 - ø14 - M10x1 - key thk.3	119,8
		[I] - CO004 - Tapered 1:8 - ø12.7 - 5/16" 24UNF-2A - key thk.3.2 (SAE)	90,4
		[J] - SCF04 - Splined ø11.7 - z=6, H=17.5, m=1.6, DIN 5482 12x9	22,6
		[K] - SCF05 - Splined ø12.344, z=9, H=19, SAE J498 9T 20/40DB	32,2
		[L] - SCF02 - Splined ø11.9, z=15, H=17.5, m=0.75	42,8
		[O] - CO002+HK - Tapered 1:8 - ø14 - M10x1, HK 14-12, key thk.3	119,8
		[P] - CI001+HK - Parallel ø12 - M10x1 with bearing HK 14-12 - key thk.3	25,8
		[Q] - SCF01 - Splined ø11.9, z=15, H=9, m=0.75	42,8
	[R] - SCF03 - Splined ø11.9, z=15, H=9, m=0.75	42,8	
	XV-2P	[A] - CI001 - Parallel ø15 - M6x1 - key thk.4	44.1
		[B] - CI002 - Parallel ø15.875 - 1/4"28-UNF key thk.4 (SAE A)	67.5
		[C] - CF001 - Miled shank ø15 - thk.8 ("BH" Standard German)	60.5
		[E] - CO001 - Tapered 1:8 - ø17,4 - M12x1,5 - key thk.4	233.2
		[F] - CO002 - Tapered 1:5 - ø17,4 - M12x1,5 - key thk.3	233.2
		[G] - SCF02 - Splined ø16,5 - z=9, H=13, m=1.6 DIN 5482 17x14	86.1
		[H] - SCF03 - Splined ø16.5 - z=9, H=18,8, m=1,6 DIN 5482 17x14	86.1
		[I] - SCF04 - Splined ø15.456 z=9, H=22.5, SAE J498 9T 16/32DP	67.1
		[K] - SCF05 - Splined ø16.5 z=9 H=8,1 m=1.6 DIN 5482 17x14	86.2
[L] - SCF01 - Splined ø16.5 z=9 H=9,2 m=1.6 DIN 5482 17x14		86.2	
[M] - CO001 - Tapered 1:8 - ø17,4 - M12x1,5 - key thk.3,2		233.2	
XV-3P	[A] - CO001 - Tapered 1:8 - ø22 - M14x1.5 - key thk.4	482	
	[B] - CI001 - Parallel ø20 - M8 - key thk.5	181	
	[C] - SCF03 - Splined ø21.5, z=13, H=25, m=1,6	223	
	[H] - CI004 - Parallel ø22.225- 1/4"28-UNF key thk.6.35 (SAE B)	180	
	[I] - SCF04 - Splined ø21.8059, z=13, H=25, SAE J498 9T 16/32DP	264	

NOTES:

For assemblies with a coupling, you should choose one as balanced as possible in order to reduce the vibrations and dynamic stresses to which the pump shaft may be subject.

Always make sure that the torque applied is less than or equal to the admissible torque of the shaft.

Do not apply a direct axial or radial load on the pump shaft; if necessary, use suitable supports.

Always use well-filtered oils containing no water or other emulsifying substance.

Never run the pump with oil and air solutions.

For pumps with outlets on the flange, it is recommended not to exceed a flow rate of

4 l/min	XV-0P
20 l/min.	XV-1P
35 l/min	XV-2P

Useful calculation formulas

SYMBOL, UNIT OF MEASUREMENT, DESCRIPTION		
qv	l/min	Flow rate
vi	cm ³ /rev.	Displacement (volume of oil displaced per complete revolution of the shaft)
n	rpm	Shaft rotation speed
p1	bar	inlet pressure
p2	bar	outlet pressure
Δp	bar	Δp=p2 - p1 difference between outlet (OUT) and inlet (IN) pressure
Ph	kW	Hydraulic power delivered
Pm	kW	Mechanical power absorbed
T	Nm	Torque absorbed by shaft
ηv	-	0.91 – 0.96 volumetric efficiency (volumetric ratio between operation under load and loadless operation)
ηm	-	0.85 – 0.90 mechanical efficiency
ηt	-	ηt = ηv x ηm total efficiency

Basic Formulas	Derived Formulas	
$qv = \frac{vi \times n}{1000} \times \eta v$	$vi = \frac{qv \times 1000}{n \times \eta v}$	$n = \frac{qv \times 1000}{vi \times \eta v}$
$T = \frac{vi \times \Delta p}{20 \times \pi \times \eta m}$	$vi = \frac{T \times 20 \times \pi \times \eta m}{\Delta p}$	$\Delta p = \frac{T \times 20 \times \pi \times \eta m}{vi}$
$Ph = \frac{qv \times \Delta p}{600}$	$qv = \frac{Ph \times 600}{\Delta p}$	$\Delta p = \frac{Ph \times 600}{qv}$
$Pm = \frac{vi \times \Delta p \times n}{600000 \times \eta m}$	$vi = \frac{Pm \times 600000 \times \eta m}{\Delta p \times n}$	$\Delta p = \frac{600000 \times \eta m}{vi \times n}$

Constructive features

PART	MATERIAL	MECHANICAL FEATURES
PUMP BODY	Extruded alloy Series 7000, heat treated and anodised	Rp = 345 N/mm ² (Yield strength) Rm = 382 N/mm ² (Breaking strength)
FLANGE AND COVER	Die-cast aluminium alloy with excellent mechanical features, heat treated and anodised	Rp = 310÷350 N/mm ² (Yield strength) Rm = 350÷400 N/mm ² (Breaking strength)
GEAR BUSH BEARINGS	Special heat-treated tin alloy with excellent mechanical features and high anti-friction capacity. Self-lubricating bushes DU	Rp = 350 N/mm ² (Yield strength) Rm = 390 N/mm ² (Breaking strength)
GEARS	Steel UNI 7846	Rs = 980 N/mm ² (Yield strength) Rm = 1270÷1570 N/mm ² (Breaking strength)
SEALS	A 727 Standard Acrylonitrile F 975 Viton FKM	70 Shore, thermal resistance 120°C 80 Shore, thermal resistance 200°C
BACK-UP RINGS	Virgin PTFE Tecnil Q3	

XV-2P CHARACTERISTIC FLOW RATE CURVES

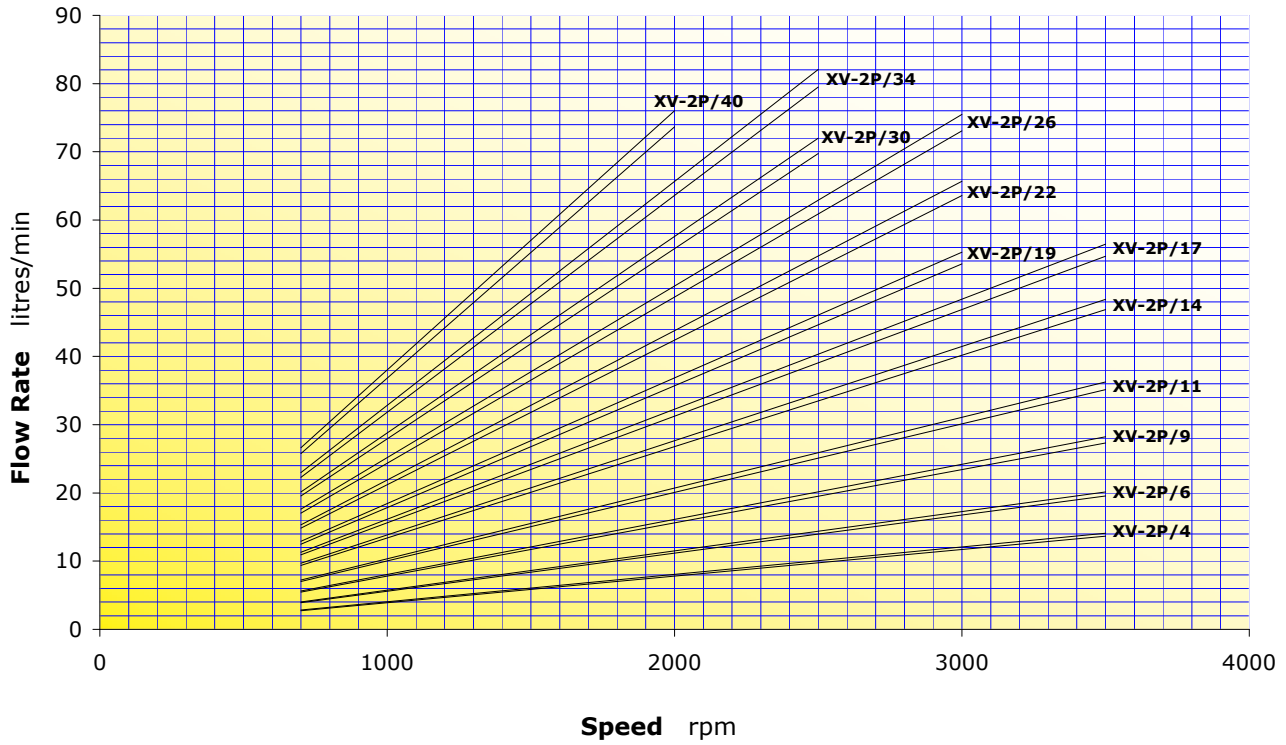

XV-2P MOTOR TORQUE

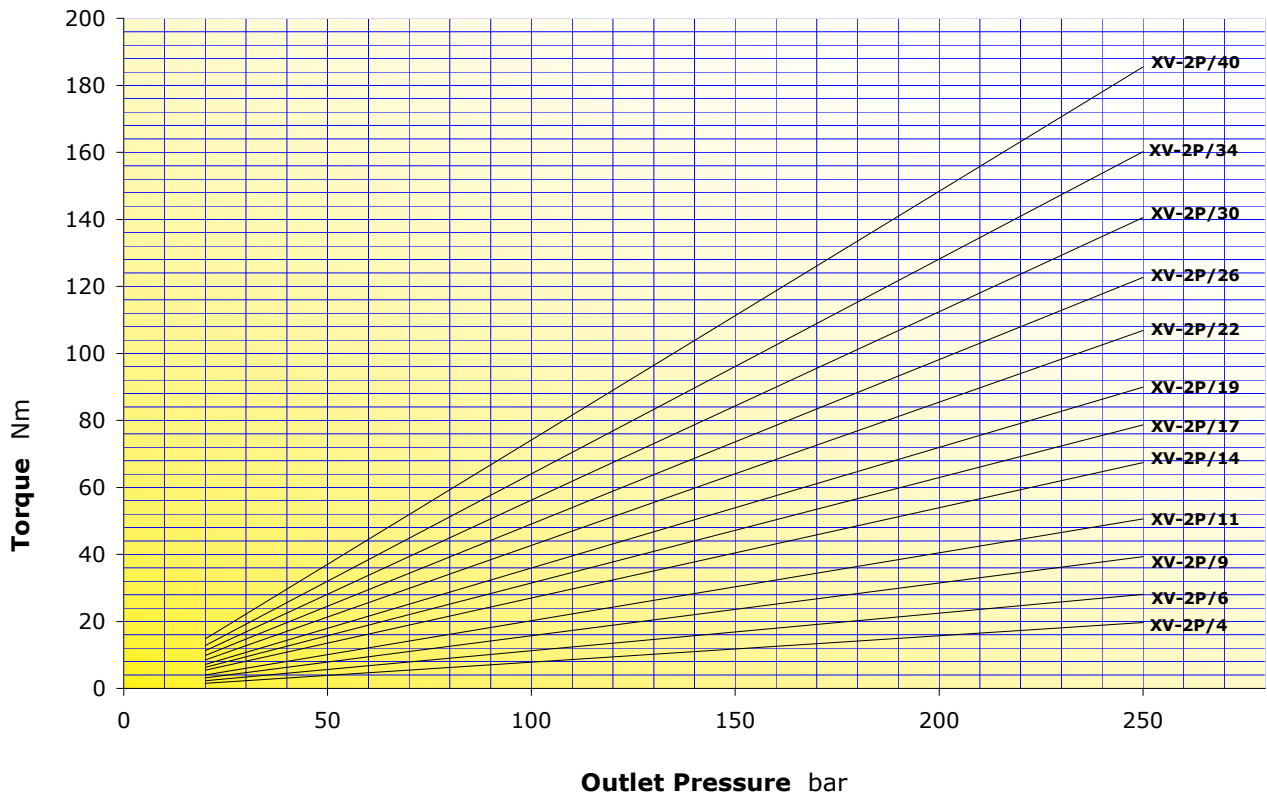

XV2-P with Flange $\varnothing 36,5$ (ref. XP- 201)

When changing the direction of rotation of the XV-2P pump, it is not necessary to change the flange, as the same one is used.

When disassembling and reassembling the pump, take special care to ensure that seals and back-up rings do not come out of place and that no foreign bodies, such as shavings or dirt in general, get inside the pump.

FLANGE $\varnothing 36,5$ (ref. XP- 201)					
<p>Remove the key, nut and washer from the shaft. Loosen and remove the fastening screws.</p>	<p>Take off the flange.</p>	<p>Take out the gears and upper bush.</p> <p>Warning!! The bush must never be turned.</p>	<p>Invert the positions of the driven and driving shafts.</p> <p>Warning! The body and cover must not be turned. Use the marking on the body as your reference.</p>	<p>Fit the previously removed flange back in place taking care to clean the body-base contact surfaces.</p>	<p>Replace the screws and tighten the nuts with a torque of 54 Nm to 58.9 Nm. Check that the shaft turns on completing the operation.</p>
<p>Note: with this rotation change system, the inlets and outlets remain unchanged.</p>					

XV2-P with Flange ø50 BH-HY (ref. da XP- 210 a: XP- 213)

When changing the direction of rotation of the XV-2P pump, it is not necessary to change the flange, as the same one is used.

When disassembling and reassembling the pump, take special care to ensure that seals and back-up rings do not come out of place and that no foreign bodies, such as shavings or dirt in general, get inside the pump.

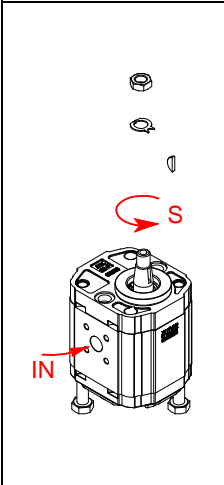
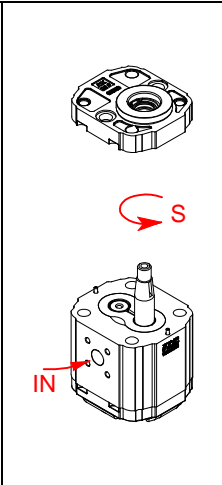
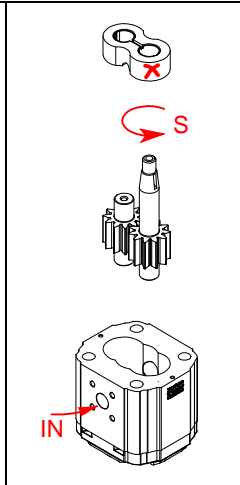
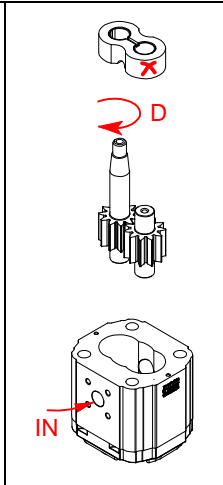
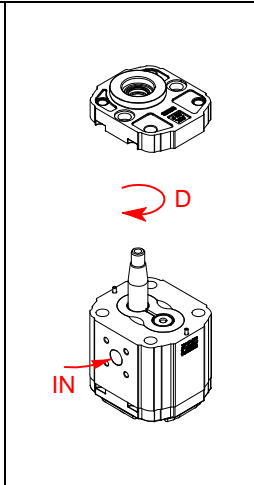
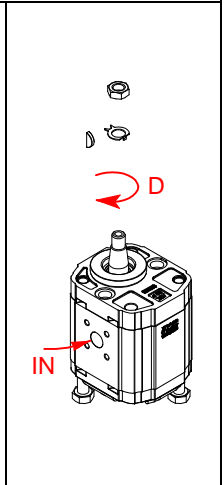
FLANGE ø50 BH-HY (ref. da XP- 210 a: XP- 213)					
					
<p>Remove the key, nut and washer from the shaft. Loosen and remove the fastening screws.</p>	<p>Take off the flange.</p>	<p>Take out the gears and upper bush.</p> <p>Warning!! The bush must never be turned.</p>	<p>Invert the positions of the driven and driving shafts.</p> <p>Warning! The body and cover must not be turned. Use the marking on the body as your reference.</p>	<p>Fit the previously removed flange back in place taking care to clean the body-base contact surfaces.</p>	<p>Replace the screws and tighten the nuts with a torque of 54 Nm to 58.9Nm. Check that the shaft turns on completing the operation.</p>
<p>Note: with this rotation change system, the inlets and outlets remain unchanged.</p>					

XV2-P with Flange ø52 BH (ref. XP- 216)

When changing the direction of rotation of the XV-2P pump, it is not necessary to change the flange, as the same one is used.

When disassembling and reassembling the pump, take special care to ensure that seals and back-up rings do not come out of place and that no foreign bodies, such as shavings or dirt in general, get inside the pump.

FLANGE ø52 BH (ref.XP- 216)					
<p>Loosen and remove the fastening screws.</p>	<p>Take off the flange.</p>	<p>Take out the gears and upper bush. Warning!! The bush must never be turned.</p>	<p>Invert the positions of the driven and driving shafts. Warning! The body and cover must not be turned. Use the marking on the body as your reference.</p>	<p>Fit the previously removed flange back in place taking care to clean the body-base contact surfaces.</p>	<p>Replace the screws and tighten the nuts with a torque of 54 Nm to 58.9Nm. Check that the shaft turns on completing the operation.</p>
<p>Note: with this rotation change system, the inlets and outlets remain unchanged.</p>					

XV2-P with Flange ø80 (ref. XP- 217)

When changing the direction of rotation of the XV-2P pump, it is not necessary to change the flange, as the same one is used.

When disassembling and reassembling the pump, take special care to ensure that seals and back-up rings do not come out of place and that no foreign bodies, such as shavings or dirt in general, get inside the pump.

FLANGE ø80 (ref.XP- 217)					
<p>Remove the key, nut and washer from the shaft. Loosen and remove the fastening screws.</p>	<p>Take off the flange.</p>	<p>Take out the gears and upper bush.</p> <p>Warning!! The bush must never be turned.</p>	<p>Invert the positions of the driven and driving shafts.</p> <p>Warning! The body and cover must not be turned. Use the marking on the body as your reference.</p>	<p>Fit the previously removed flange back in place taking care to clean the body-base contact surfaces.</p>	<p>Replace the screws and tighten the nuts with a torque of 54 Nm to 58.9 Nm.</p> <p>Check that the shaft turns on completing the operation.</p>
<p>Note: with this rotation change system, the inlets and outlets remain unchanged.</p>					

XV2-P with Flange ø82,5 SAE-A (ref. da XP- 219 a: XP- 224)

When changing the direction of rotation of the XV-2P pump, it is not necessary to change the flange, as the same one is used.

When disassembling and reassembling the pump, take special care to ensure that seals and back-up rings do not come out of place and that no foreign bodies, such as shavings or dirt in general, get inside the pump.

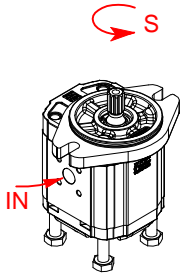
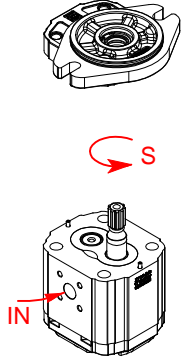
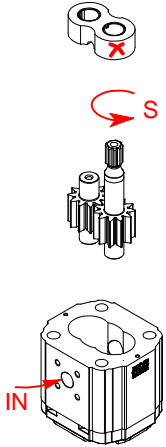
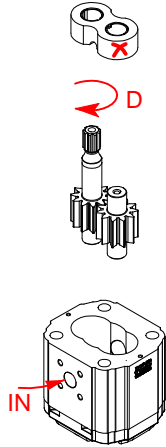
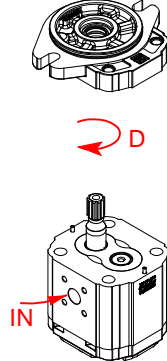
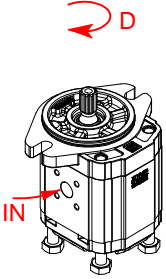
FLANGE ø82,5 SAE-A (ref. XP- 219)					
					
<p>Loosen and remove the fastening screws.</p>	<p>Take off the flange.</p>	<p>Take out the gears and upper bush. Warning!! The bush must never be turned.</p>	<p>Invert the positions of the driven and driving shafts. Warning! The body and cover must not be turned. Use the marking on the body as your reference.</p>	<p>Fit the previously removed flange back in place taking care to clean the body-base contact surfaces.</p>	<p>Replace the screws and tighten the nuts with a torque of 54 Nm to 58.9Nm. Check that the shaft turns on completing the operation.</p>
<p>Note: with this rotation change system, the inlets and outlets remain unchanged.</p>					

unidirectional pump - series XV

XV-2P

STANDARD EUROPEAN PUMP
 ø36.5 FLANGE - TAPER SHAFT



X 2 P 51 02 E P O A

Series	X	series XV
Group	2	group 2
Category	P	unidirectional pump
Displacement	51	17
Flange	02	Ø36.5 STANDARD EUROPEAN right rotation
Shaft	E	CO001 - Tapered 1:8 - ø17.4 - M12x1.5 - key thk.4
Body	IN	P inlet - Ø40 Ø20 M8
	OUT	O outlet - Ø30 Ø13.5 M6
Cover	A	standard

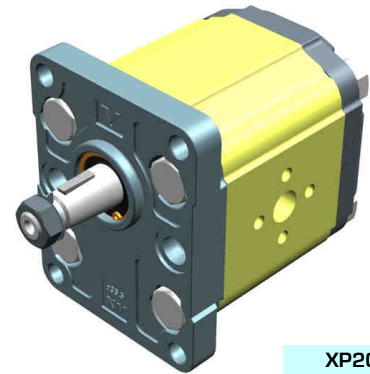

XP201

Technical data table

TYPE	Displacement cm3/rev	Max. Pressure		CODE	
		P1 bar	P3 bar	Left rotation	Right rotation
XV-2P/04	4,20	260	300	X 2 P 41 01 E O O A	X 2 P 41 02 E O O A
XV-2P/06	6,00	260	300	X 2 P 43 01 E O O A	X 2 P 43 02 E O O A
XV-2P/09	8,40	260	300	X 2 P 45 01 E O O A	X 2 P 45 02 E O O A
XV-2P/11	10,80	260	300	X 2 P 47 01 E O O A	X 2 P 47 02 E O O A
XV-2P/14	14,40	250	290	X 2 P 49 01 E P O A	X 2 P 49 02 E P O A
XV-2P/17	16,80	230	270	X 2 P 51 01 E P O A	X 2 P 51 02 E P O A
XV-2P/19	19,20	210	250	X 2 P 53 01 E P O A	X 2 P 53 02 E P O A
XV-2P/22	22,80	200	240	X 2 P 55 01 E P O A	X 2 P 55 02 E P O A
XV-2P/26	26,20	170	210	X 2 P 57 01 E Q P A	X 2 P 57 02 E Q P A
XV-2P/30	30,00	160	200	X 2 P 59 01 E Q P A	X 2 P 59 02 E Q P A
XV-2P/34	34,20	150	190	X 2 P 61 01 E Q P A	X 2 P 61 02 E Q P A
XV-2P/40	39,60	140	180	X 2 P 63 01 E Q P A	X 2 P 63 02 E Q P A

P1) Max. working pressure - P3) Max. peak pressure

For heavy-duty applications, it is recommended to check the admissible torque of the shaft

Dimensions table

TYPE	Weight kg	A	B	C	D	E	F	D	E	F
		mm	mm	mm	IN			OUT		
XV-2P/04	2,200	87,2	41,7	77,2	ø13,5	30	M6x1	ø13,5	30	M6x1
XV-2P/06	2,300	90,2	43,2	80,2	ø13,5	30	M6x1	ø13,5	30	M6x1
XV-2P/09	2,400	94,2	45,2	84,2	ø13,5	30	M6x1	ø13,5	30	M6x1
XV-2P/11	2,500	98,2	47,2	88,2	ø13,5	30	M6x1	ø13,5	30	M6x1
XV-2P/14	2,700	104,2	50,2	94,2	ø20	40	M8X1,25	ø13,5	30	M6x1
XV-2P/17	2,800	108,2	52,2	98,2	ø20	40	M8X1,25	ø13,5	30	M6x1
XV-2P/19	2,900	112,2	54,2	102,2	ø20	40	M8X1,25	ø13,5	30	M6x1
XV-2P/22	3,050	118,2	57,2	108,2	ø20	40	M8X1,25	ø13,5	30	M6x1
XV-2P/26	3,150	122,2	59,2	112,2	ø23,5	40	M8X1,25	ø20	40	M8X1,25
XV-2P/30	3,400	130,2	63,2	120,2	ø23,5	40	M8X1,25	ø20	40	M8X1,25
XV-2P/34	3,600	137,2	66,7	127,2	ø23,5	40	M8X1,25	ø20	40	M8X1,25
XV-2P/40	3,800	146,2	71,2	136,2	ø23,5	40	M8X1,25	ø20	40	M8X1,25

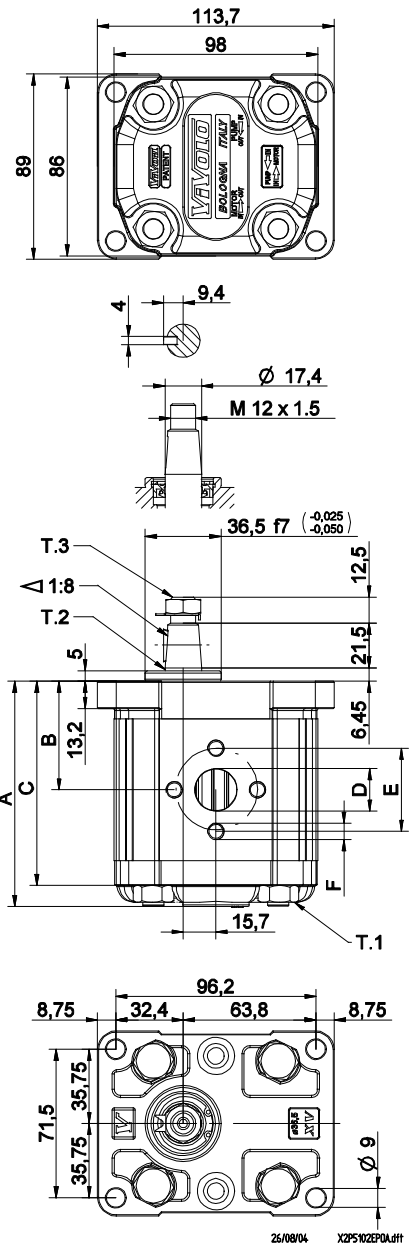

T.1 = 54÷58.9 [Nm] - screw tightening torque M10

T.3 = 40 [Nm] - torque wrench setting 19

T.2 = 233.2 [Nm] - admissible shaft torque (N.B. When choosing a shaft, always check the admissible torque).

Table of variations

XV-2P

ø36.5 FLANGE

ø36.5 FLANGE				Shaft				Cover			
Left rotation		Right rotation						Left rotation		Right rotation	
	01		02	CI001 - Parallel T.2 = 44.1 [Nm]	A	CI002 - Parallel T.2 = 67.5 [Nm]	B				A
	03		04	CO001 - Tapered T.2 = 233.2 [Nm]	E	CO002 - Tapered T.2 = 233.2 [Nm]	F				B
	05		06	SCF02 - Splined T.2 = 86.1 [Nm]	G	SCF03 - Splined T.2 = 86.1 [Nm]	H				C
	07		08	SCF04 - Splined T.2 = 67.1 [Nm]	I	SCF01 - Splined T.2 = 86.2 [Nm]	L				D
											N
											O

Displacement	
TYPE	CODE
XV-2P/04	41
XV-2P/06	43
XV-2P/09	45
XV-2P/11	47
XV-2P/14	49
XV-2P/17	51
XV-2P/19	53
XV-2P/22	55
XV-2P/26	57
XV-2P/30	59
XV-2P/34	61
XV-2P/40	63

Standard bodies						
Displacement cm ³ /rev	Standard threads					
	04	O - O	S - R	B - B	L - M	Z - Z
06	O - O	S - R	B - B	L - M	Z - Z	
09	O - O	S - R	B - B	L - M	Z - Z	
11	O - O	S - R	B - B	L - M	Z - Z	
14	P - O	S - R	C - B	L - M	Z - Z	
17	P - O	S - R	C - B	L - M	Z - Z	
19	P - O	S - R	C - B	L - M	Z - Z	
22	P - O	S - R	C - B	L - M	Z - Z	
26	Q - P	S - R	D - C	L - M	Z - Z	
30	Q - P	S - S	D - C	L - M	Z - Z	
34	Q - P	S - S	D - C	L - M	Z - Z	
40	Q - P	S - S	D - C	L - M	Z - Z	

Table showing standard flange and thread combinations available in stock

Body (threads/flanges)													
	A		B		C		D		E		F		G
	H		I		L		M		N		O		P
	Q		R		S		T		U		V		Z

unidirectional pump - series XV

XV-2P

STANDARD EUROPEAN PUMP
 ø36.5 FLANGE - TAPER SHAFT

X 2 P 51 02 E C B A

Series	X	series XV
Group	2	group 2
Category	P	unidirectional pump
Displacement	51	17
Flange	02	Ø36.5 STANDARD EUROPEAN right rotation
Shaft	E	CO001 - Tapered 1:8 - ø17.4 - M12x1.5 - key thk.4
Body	IN	inlet - 3/4" GAS
	OUT	outlet - 1/2" GAS
Cover	A	standard



XP207

Technical data table

TYPE	Displacement cm3/rev	Max. Pressure		CODE	
		P1 bar	P3 bar	Left rotation	Right rotation
XV-2P/04	4,20	260	300	X 2 P 41 01 E B B A	X 2 P 41 02 E B B A
XV-2P/06	6,00	260	300	X 2 P 43 01 E B B A	X 2 P 43 02 E B B A
XV-2P/09	8,40	260	300	X 2 P 45 01 E B B A	X 2 P 45 02 E B B A
XV-2P/11	10,80	260	300	X 2 P 47 01 E B B A	X 2 P 47 02 E B B A
XV-2P/14	14,40	250	290	X 2 P 49 01 E C B A	X 2 P 49 02 E C B A
XV-2P/17	16,80	230	270	X 2 P 51 01 E C B A	X 2 P 51 02 E C B A
XV-2P/19	19,20	210	250	X 2 P 53 01 E C B A	X 2 P 53 02 E C B A
XV-2P/22	22,80	200	240	X 2 P 55 01 E C B A	X 2 P 55 02 E C B A
XV-2P/26	26,20	170	210	X 2 P 57 01 E D C A	X 2 P 57 02 E D C A
XV-2P/30	30,00	160	200	X 2 P 59 01 E D C A	X 2 P 59 02 E D C A
XV-2P/34	34,20	150	190	X 2 P 61 01 E D C A	X 2 P 61 02 E D C A
XV-2P/40	39,60	140	180	X 2 P 63 01 E D C A	X 2 P 63 02 E D C A

P1) Max. working pressure - P3) Max. peak pressure

For heavy-duty applications, it is recommended to check the admissible torque of the shaft

Dimensions table

TYPE	Weight kg	A	B	C	D	D
		mm	mm	mm	IN	OUT
XV-2P/04	2,200	87,2	41,7	77,2	1/2" BSPP	1/2" BSPP
XV-2P/06	2,300	90,2	43,2	80,2	1/2" BSPP	1/2" BSPP
XV-2P/09	2,400	94,2	45,2	84,2	1/2" BSPP	1/2" BSPP
XV-2P/11	2,500	98,2	47,2	88,2	1/2" BSPP	1/2" BSPP
XV-2P/14	2,700	104,2	50,2	94,2	3/4" BSPP	1/2" BSPP
XV-2P/17	2,800	108,2	52,2	98,2	3/4" BSPP	1/2" BSPP
XV-2P/19	2,900	112,2	54,2	102,2	3/4" BSPP	1/2" BSPP
XV-2P/22	3,050	118,2	57,2	108,2	3/4" BSPP	1/2" BSPP
XV-2P/26	3,150	122,2	59,2	112,2	1" BSPP	3/4" BSPP
XV-2P/30	3,400	130,2	63,2	120,2	1" BSPP	3/4" BSPP
XV-2P/34	3,600	137,2	66,7	127,2	1" BSPP	3/4" BSPP
XV-2P/40	3,800	146,2	71,2	136,2	1" BSPP	3/4" BSPP

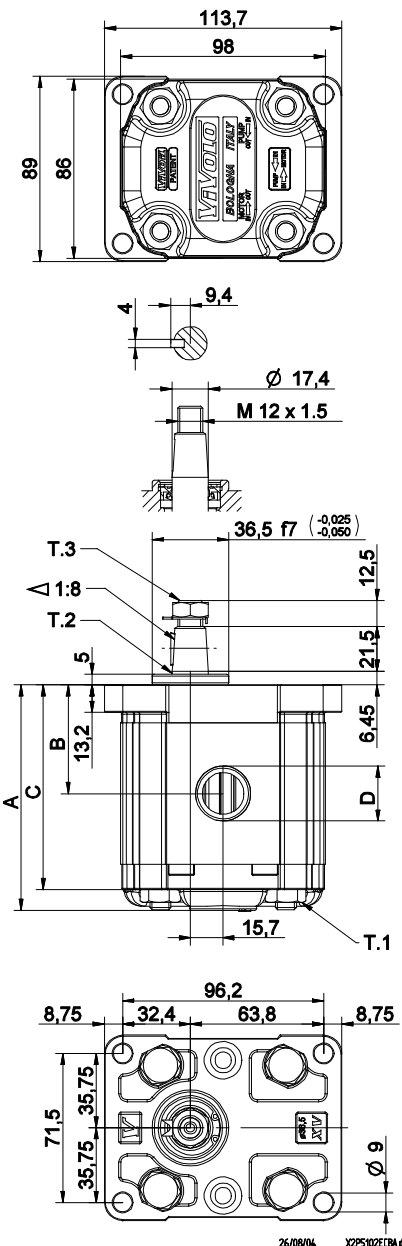

T.1 = 54÷58.9 [Nm] - screw tightening torque M10

T.3 = 40 [Nm] - torque wrench setting 19

T.2 = 233.2 [Nm] - admissible shaft torque (N.B. When choosing a shaft, always check the admissible torque).

Table of variations

XV-2P

ø36.5 FLANGE

ø36.5 FLANGE				Shaft				Cover			
Left rotation		Right rotation						Left rotation		Right rotation	
	01		02	CI001 - Parallel T.2 = 44.1 [Nm]	A	CI002 - Parallel T.2 = 67.5 [Nm]	B				A
	03		04	CO001 - Tapered T.2 = 233.2 [Nm]	E	CO002 - Tapered T.2 = 233.2 [Nm]	F				B
	05		06	SCF02 - Splined T.2 = 86.1 [Nm]	G	SCF03 - Splined T.2 = 86.1 [Nm]	H				C
	07		08	SCF04 - Splined T.2 = 67.1 [Nm]	I	SCF01 - Splined T.2 = 86.2 [Nm]	L				D
											N
											O

Displacement	
TYPE	CODE
XV-2P/04	41
XV-2P/06	43
XV-2P/09	45
XV-2P/11	47
XV-2P/14	49
XV-2P/17	51
XV-2P/19	53
XV-2P/22	55
XV-2P/26	57
XV-2P/30	59
XV-2P/34	61
XV-2P/40	63

Standard bodies						
Displacement cm ³ /rev	Standard threads					
	04	O - O	S - R	B - B	L - M	Z - Z
06	O - O	S - R	B - B	L - M	Z - Z	
09	O - O	S - R	B - B	L - M	Z - Z	
11	O - O	S - R	B - B	L - M	Z - Z	
14	P - O	S - R	C - B	L - M	Z - Z	
17	P - O	S - R	C - B	L - M	Z - Z	
19	P - O	S - R	C - B	L - M	Z - Z	
22	P - O	S - R	C - B	L - M	Z - Z	
26	Q - P	S - R	D - C	L - M	Z - Z	
30	Q - P	S - S	D - C	L - M	Z - Z	
34	Q - P	S - S	D - C	L - M	Z - Z	
40	Q - P	S - S	D - C	L - M	Z - Z	

Table showing standard flange and thread combinations available in stock

Body (threads/flanges)													
	A		B		C		D		E		F		G
	H		I		L		M		N		O		P
	Q		R		S		T		U		V	Gehäuse Geschlossen Z	

unidirectional pump - series XV

XV-2P

"BH" TYPE PUMP
 ø50 BODY-SHAPED FLANGE - TAPER SHAFT

X 2 P 51 12 F S R A

Series	X	series XV
Group	2	group 2
Category	P	unidirectional pump
Displacement	51	17
Flange	12	ø50 BH GERMAN STANDARDIZED right rotation
Shaft	F	CO002 - Tapered 1:5 - ø17.4 - M12x1.5 - key thk.3
Body	IN	inlet - Ø40 a 45° Ø20 M6
	OUT	outlet - Ø35 a 45° Ø15 M6
Cover	A	standard

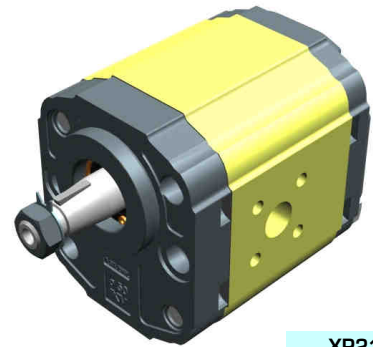

XP210

Technical data table

TYPE	Displacement cm3/rev	Max. Pressure		CODE	
		P1 bar	P3 bar	Left rotation	Right rotation
XV-2P/04	4,20	260	300	X 2 P 41 11 F S R A	X 2 P 41 12 F S R A
XV-2P/06	6,00	260	300	X 2 P 43 11 F S R A	X 2 P 43 12 F S R A
XV-2P/09	8,40	260	300	X 2 P 45 11 F S R A	X 2 P 45 12 F S R A
XV-2P/11	10,80	260	300	X 2 P 47 11 F S R A	X 2 P 47 12 F S R A
XV-2P/14	14,40	250	290	X 2 P 49 11 F S R A	X 2 P 49 12 F S R A
XV-2P/17	16,80	230	270	X 2 P 51 11 F S R A	X 2 P 51 12 F S R A
XV-2P/19	19,20	210	250	X 2 P 53 11 F S R A	X 2 P 53 12 F S R A
XV-2P/22	22,80	200	240	X 2 P 55 11 F S R A	X 2 P 55 12 F S R A
XV-2P/26	26,20	170	210	X 2 P 57 11 F S R A	X 2 P 57 12 F S R A
XV-2P/30	30,00	160	200	X 2 P 59 11 F S S A	X 2 P 59 12 F S S A
XV-2P/34	34,20	150	190	X 2 P 61 11 F S S A	X 2 P 61 12 F S S A
XV-2P/40	39,60	140	180	X 2 P 63 11 F S S A	X 2 P 63 12 F S S A

P1) Max. working pressure - P3) Max. peak pressure

For heavy-duty applications, it is recommended to check the admissible torque of the shaft

Dimensions table

TYPE	Weight kg	A	B	C	D	E	F	D	E	F
		mm	mm	mm	IN			OUT		
XV-2P/04	2,100	87,2	38,6	77,2	ø20	40	M6x1	ø15	35	M6x1
XV-2P/06	2,200	90,2	38,6	80,2	ø20	40	M6x2	ø15	35	M6x1
XV-2P/09	2,300	94,2	40,6	84,2	ø20	40	M6x3	ø15	35	M6x1
XV-2P/11	2,400	98,2	45,0	88,2	ø20	40	M6x4	ø15	35	M6x1
XV-2P/14	2,600	104,2	45,0	94,2	ø20	40	M6x5	ø15	35	M6x1
XV-2P/17	2,700	108,2	45,0	98,2	ø20	40	M6x6	ø15	35	M6x1
XV-2P/19	2,800	112,2	45,0	102,2	ø20	40	M6x7	ø15	35	M6x1
XV-2P/22	2,950	118,2	52,5	108,2	ø20	40	M6x8	ø15	35	M6x1
XV-2P/26	3,050	122,2	52,5	112,2	ø20	40	M6x9	ø15	35	M6x1
XV-2P/30	3,300	130,2	60,7	120,2	ø20	40	M6x10	ø20	40	M6x1
XV-2P/34	3,500	137,2	60,7	127,2	ø20	40	M6x11	ø20	40	M6x1
XV-2P/40	3,700	146,2	60,7	136,2	ø20	40	M6x12	ø20	40	M6x1

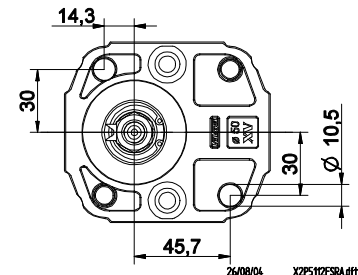
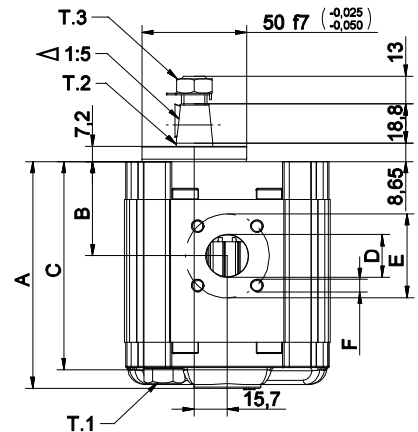
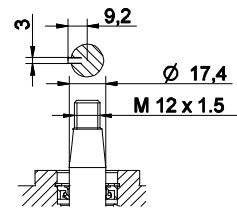
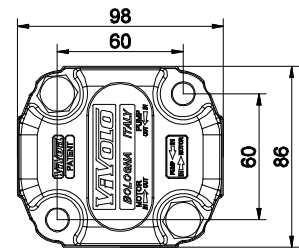

T.1 = 54÷58.9 [Nm] - screw tightening torque M10

T.3 = 40 [Nm] - torque wrench setting 19

T.2 = 233.2 [Nm] - admissible shaft torque (N.B. When choosing a shaft, always check the admissible torque).

Table of variations

XV-2P

ø50 "BH" Body-Shaped FLANGE

ø50 "BH" Body-Shaped FLANGE				Shaft				Cover							
Left rotation		Right rotation		Parallel		Tapered		Spline		Left rotation		Right rotation			
	11		12	CI001 - Parallel T.2 = 44.1 [Nm]	A	CI002 - Parallel T.2 = 67.5 [Nm]	B		13		14		15		16
	17		18	CO001 - Tapered T.2 = 233.2 [Nm]	E	CO002 - Tapered T.2 = 233.2 [Nm]	F		19		20		21		22
	23		24	SCF03 - Spline T.2 = 86.1 [Nm]	H				25		26		27		28
	29		30						31		32		33		34

Displacement	
TYPE	CODE
XV-2P/04	41
XV-2P/06	43
XV-2P/09	45
XV-2P/11	47
XV-2P/14	49
XV-2P/17	51
XV-2P/19	53
XV-2P/22	55
XV-2P/26	57
XV-2P/30	59
XV-2P/34	61
XV-2P/40	63

Displacement cm ³ /rev	Standard threads					
	O - O	S - R	B - B	L - M	Z - Z	
04	O - O	S - R	B - B	L - M	Z - Z	
06	O - O	S - R	B - B	L - M	Z - Z	
09	O - O	S - R	B - B	L - M	Z - Z	
11	O - O	S - R	B - B	L - M	Z - Z	
14	P - O	S - R	C - B	L - M	Z - Z	
17	P - O	S - R	C - B	L - M	Z - Z	
19	P - O	S - R	C - B	L - M	Z - Z	
22	P - O	S - R	C - B	L - M	Z - Z	
26	Q - P	S - R	D - C	L - M	Z - Z	
30	Q - P	S - S	D - C	L - M	Z - Z	
34	Q - P	S - S	D - C	L - M	Z - Z	
40	Q - P	S - S	D - C	L - M	Z - Z	

Table showing standard flange and thread combinations available in stock

	N
	O

Body (threads/flanges)													
	A		B		C		D		E		F		G
	H		I		L		M		N		O		P
	Q		R		S		T		U		V		Z

unidirectional pump - series XV

XV-2P

"HY" TYPE PUMP
 ø50 BODY-SHAPED FLANGE - TAPER SHAFT

X 2 P 51 22 F S R A

Series	X	series XV
Group	2	group 2
Category	P	unidirectional pump
Displacement	51	17
Flange	22	ø50 HY GERMAN STANDARDIZED right rotation
Shaft	F	CO002 - Tapered 1:5 - ø17.4 - M12x1.5 - key thk.3
Body	IN	inlet - Ø40 a 45° Ø20 M6
	OUT	outlet - Ø35 a 45° Ø15 M6
Cover	A	standard

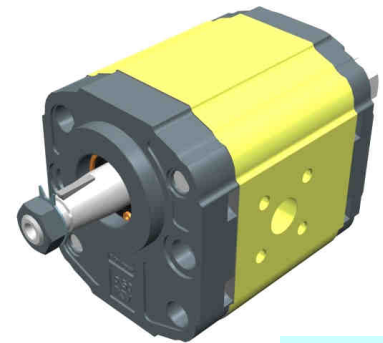

XP213

Technical data table

TYPE	Displacement cm3/rev	Max. Pressure		CODE	
		P1 bar	P3 bar	Left rotation	Right rotation
XV-2P/04	4,20	260	300	X 2 P 41 21 F S R A	X 2 P 41 22 F S R A
XV-2P/06	6,00	260	300	X 2 P 43 21 F S R A	X 2 P 43 22 F S R A
XV-2P/09	8,40	260	300	X 2 P 45 21 F S R A	X 2 P 45 22 F S R A
XV-2P/11	10,80	260	300	X 2 P 47 21 F S R A	X 2 P 47 22 F S R A
XV-2P/14	14,40	250	290	X 2 P 49 21 F S R A	X 2 P 49 22 F S R A
XV-2P/17	16,80	230	270	X 2 P 51 21 F S R A	X 2 P 51 22 F S R A
XV-2P/19	19,20	210	250	X 2 P 53 21 F S R A	X 2 P 53 22 F S R A
XV-2P/22	22,80	200	240	X 2 P 55 21 F S R A	X 2 P 55 22 F S R A
XV-2P/26	26,20	170	210	X 2 P 57 21 F S R A	X 2 P 57 22 F S R A
XV-2P/30	30,00	160	200	X 2 P 59 21 F S S A	X 2 P 59 22 F S S A
XV-2P/34	34,20	150	190	X 2 P 61 21 F S S A	X 2 P 61 22 F S S A
XV-2P/40	39,60	140	180	X 2 P 63 21 F S S A	X 2 P 63 22 F S S A

P1) Max. working pressure - P3) Max. peak pressure

For heavy-duty applications, it is recommended to check the admissible torque of the shaft

Dimensions table

TYPE	Weight kg	A	B	C	D	E	F	D	E	F
		mm	mm	mm	IN			OUT		
XV-2P/04	2,100	87,2	38,6	77,2	ø20	40	M6x1	ø15	35	M6x1
XV-2P/06	2,200	90,2	38,6	80,2	ø20	40	M6x2	ø15	35	M6x1
XV-2P/09	2,300	94,2	40,6	84,2	ø20	40	M6x3	ø15	35	M6x1
XV-2P/11	2,400	98,2	45,0	88,2	ø20	40	M6x4	ø15	35	M6x1
XV-2P/14	2,600	104,2	45,0	94,2	ø20	40	M6x5	ø15	35	M6x1
XV-2P/17	2,700	108,2	45,0	98,2	ø20	40	M6x6	ø15	35	M6x1
XV-2P/19	2,800	112,2	45,0	102,2	ø20	40	M6x7	ø15	35	M6x1
XV-2P/22	2,950	118,2	52,5	108,2	ø20	40	M6x8	ø15	35	M6x1
XV-2P/26	3,050	122,2	52,5	112,2	ø20	40	M6x9	ø15	35	M6x1
XV-2P/30	3,300	130,2	60,7	120,2	ø20	40	M6x10	ø20	40	M6x1
XV-2P/34	3,500	137,2	60,7	127,2	ø20	40	M6x11	ø20	40	M6x1
XV-2P/40	3,700	146,2	60,7	136,2	ø20	40	M6x12	ø20	40	M6x1

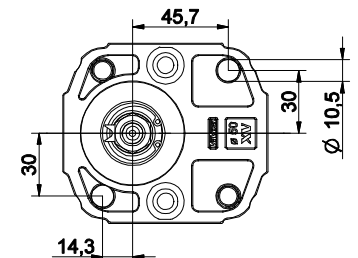
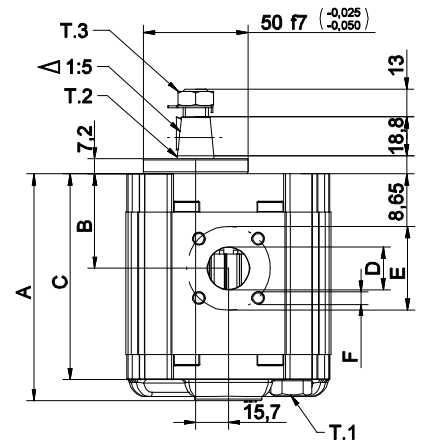
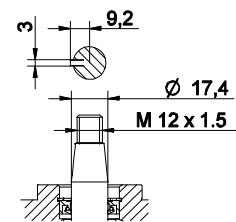
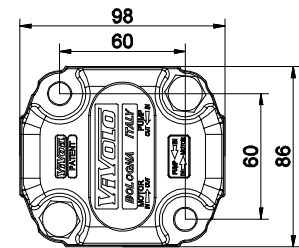

26/08/04 X2P5122FSRA.dft

T.1 = 54÷58.9 [Nm] - screw tightening torque M10

T.3 = 40 [Nm] - torque wrench setting 19

T.2 = 233.2 [Nm] - admissible shaft torque (N.B. When choosing a shaft, always check the admissible torque).

Table of variations

XV-2P

ø50 "HY" Body-Shaped FLANGE

ø50 "HY" Body-Shaped FLANGE				Shaft				Cover			
Left rotation		Right rotation		Left rotation		Right rotation		Left rotation		Right rotation	
	21		22	CI001 - Parallel T.2 = 44.1 [Nm] 	A	CI002 - Parallel T.2 = 67.5 [Nm] 	B			A	
	23		24	CO001 - Tapered T.2 = 233.2 [Nm] 	E	CO002 - Tapered T.2 = 233.2 [Nm] 	F			B	
	25		26	SCF03 - Splined T.2 = 86.1 [Nm] 	H					C	
	27		28							D	

Displacement	
TYPE	CODE
XV-2P/04	41
XV-2P/06	43
XV-2P/09	45
XV-2P/11	47
XV-2P/14	49
XV-2P/17	51
XV-2P/19	53
XV-2P/22	55
XV-2P/26	57
XV-2P/30	59
XV-2P/34	61
XV-2P/40	63

Displacement cm ³ /rev	Standard threads					
	O - O	S - R	B - B	L - M	Z - Z	
04	O - O	S - R	B - B	L - M	Z - Z	
06	O - O	S - R	B - B	L - M	Z - Z	
09	O - O	S - R	B - B	L - M	Z - Z	
11	O - O	S - R	B - B	L - M	Z - Z	
14	P - O	S - R	C - B	L - M	Z - Z	
17	P - O	S - R	C - B	L - M	Z - Z	
19	P - O	S - R	C - B	L - M	Z - Z	
22	P - O	S - R	C - B	L - M	Z - Z	
26	Q - P	S - R	D - C	L - M	Z - Z	
30	Q - P	S - S	D - C	L - M	Z - Z	
34	Q - P	S - S	D - C	L - M	Z - Z	
40	Q - P	S - S	D - C	L - M	Z - Z	

Table showing standard flange and thread combinations available in stock

		N	
Internal drainage			
		O	
External drainage			

Body (threads/flanges)													
	A		B		C		D		E		F		G
	H		I		L		M		N		O		P
	Q		R		S		T		U		V		Z

unidirectional pump - series XV

XV-2P

STANDARD GERMAN "BH" TYPE PUMP
 ø52 BODY-SHAPED FLANGE - MILLED SHANK

X 2 P 51 32 C S R A

Series	X	series XV
Group	2	group 2
Category	P	unidirectional pump
Displacement	51	17
Flange	32	Ø52 BH GERMAN STANDARDIZED right rotation (with OR)
Shaft	C	CF001 - Milled shank ø15 - thk.8 ("BH" Standard German)
Body	IN	S inlet - Ø40 a 45° Ø20 M6
	OUT	R outlet - Ø35 a 45° Ø15 M6
Cover	A	standard

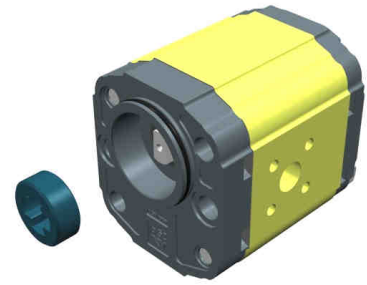

XP216

Technical data table

TYPE	Displacement cm3/rev	Max. Pressure		CODE	
		P1 bar	P3 bar	Left rotation	Right rotation
XV-2P/04	4,20	260	300	X 2 P 41 31 C S R A	X 2 P 41 32 C S R A
XV-2P/06	6,00	260	300	X 2 P 43 31 C S R A	X 2 P 43 32 C S R A
XV-2P/09	8,40	260	300	X 2 P 45 31 C S R A	X 2 P 45 32 C S R A
XV-2P/11	10,80	260	300	X 2 P 47 31 C S R A	X 2 P 47 32 C S R A
XV-2P/14	14,40	250	290	X 2 P 49 31 C S R A	X 2 P 49 32 C S R A
XV-2P/17	16,80	230	270	X 2 P 51 31 C S R A	X 2 P 51 32 C S R A
XV-2P/19	19,20	210	250	X 2 P 53 31 C S R A	X 2 P 53 32 C S R A
XV-2P/22	22,80	200	240	X 2 P 55 31 C S R A	X 2 P 55 32 C S R A
XV-2P/26	26,20	170	210	X 2 P 57 31 C S R A	X 2 P 57 32 C S R A
XV-2P/30	30,00	160	200	X 2 P 59 31 C S S A	X 2 P 59 32 C S S A
XV-2P/34	34,20	150	190	X 2 P 61 31 C S S A	X 2 P 61 32 C S S A
XV-2P/40	39,60	140	180	X 2 P 63 31 C S S A	X 2 P 63 32 C S S A

P1) Max. working pressure - P3) Max. peak pressure

For heavy-duty applications, it is recommended to check the admissible torque of the shaft

Dimensions table

TYPE	Weight kg	A	B	C	D	E	F	D	E	F
		mm	mm	mm	IN			OUT		
XV-2P/04	2,100	87,2	38,6	77,2	ø20	40	M6x1	ø15	35	M6x1
XV-2P/06	2,200	90,2	38,6	80,2	ø20	40	M6x2	ø15	35	M6x1
XV-2P/09	2,300	94,2	40,6	84,2	ø20	40	M6x3	ø15	35	M6x1
XV-2P/11	2,400	98,2	45,0	88,2	ø20	40	M6x4	ø15	35	M6x1
XV-2P/14	2,600	104,2	45,0	94,2	ø20	40	M6x5	ø15	35	M6x1
XV-2P/17	2,700	108,2	45,0	98,2	ø20	40	M6x6	ø15	35	M6x1
XV-2P/19	2,800	112,2	45,0	102,2	ø20	40	M6x7	ø15	35	M6x1
XV-2P/22	2,950	118,2	52,5	108,2	ø20	40	M6x8	ø15	35	M6x1
XV-2P/26	3,050	122,2	52,5	112,2	ø20	40	M6x9	ø15	35	M6x1
XV-2P/30	3,300	130,2	60,7	120,2	ø20	40	M6x10	ø20	40	M6x1
XV-2P/34	3,500	137,2	60,7	127,2	ø20	40	M6x11	ø20	40	M6x1
XV-2P/40	3,700	146,2	60,7	136,2	ø20	40	M6x12	ø20	40	M6x1

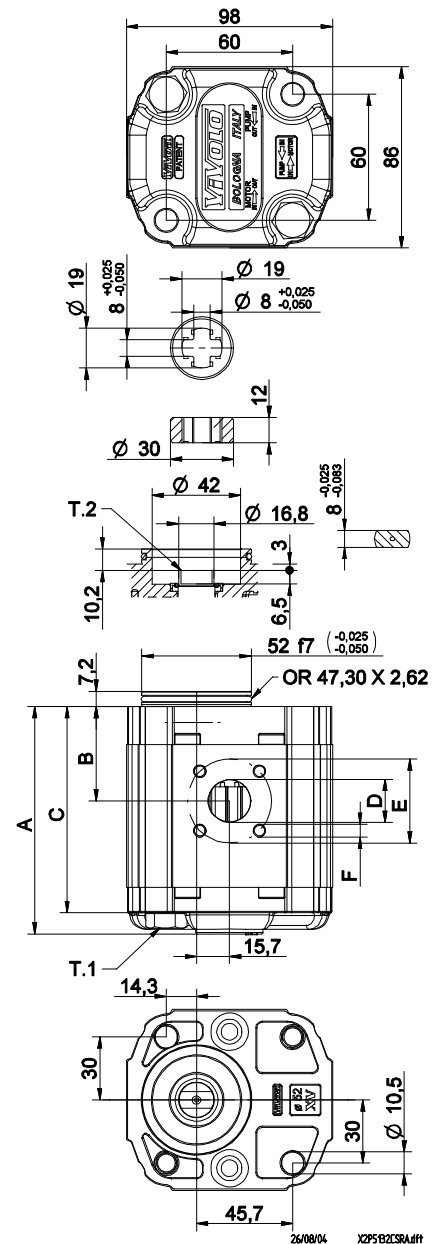

T.1 = 54÷58.9 [Nm] - screw tightening torque M10

T.2 = 60.5 [Nm] - admissible shaft torque (N.B. When choosing a shaft, always check the admissible torque).

Table of variations

XV-2P

Standard German ø52 "BH" FLANGE

Standard German ø52 "BH" FLANGE				Shaft				Cover			
Left rotation		Right rotation		CF001 - Milled shank		SCF05 - Splined		Left rotation		Right rotation	
	31		32		C		K				A
	33		34		L						B
	35		36								C
	37		38								D

Displacement	
TYPE	CODE
XV-2P/04	41
XV-2P/06	43
XV-2P/09	45
XV-2P/11	47
XV-2P/14	49
XV-2P/17	51
XV-2P/19	53
XV-2P/22	55
XV-2P/26	57
XV-2P/30	59
XV-2P/34	61
XV-2P/40	63

Displacement cm ³ /rev	Standard threads					
	O - O	S - R	B - B	L - M	Z - Z	
04	O - O	S - R	B - B	L - M	Z - Z	
06	O - O	S - R	B - B	L - M	Z - Z	
09	O - O	S - R	B - B	L - M	Z - Z	
11	O - O	S - R	B - B	L - M	Z - Z	
14	P - O	S - R	C - B	L - M	Z - Z	
17	P - O	S - R	C - B	L - M	Z - Z	
19	P - O	S - R	C - B	L - M	Z - Z	
22	P - O	S - R	C - B	L - M	Z - Z	
26	Q - P	S - R	D - C	L - M	Z - Z	
30	Q - P	S - S	D - C	L - M	Z - Z	
34	Q - P	S - S	D - C	L - M	Z - Z	
40	Q - P	S - S	D - C	L - M	Z - Z	

Table showing standard flange and thread combinations available in stock

			N
Internal drainage			
			O
External drainage			

Body (threads/flanges)													
	A		B		C		D		E		F		G
	H		I		L		M		N		O		P
	Q		R		S		T		U		V	Gehäuse Geschlossen Z	

unidirectional pump - series XV

XV-2P

STANDARD GERMAN PUMP
ø80 FLANGE - TAPER SHAFT

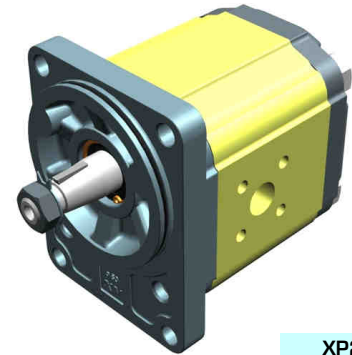

XP217

X 2 P 51 42 F S R A

Series	X	series XV
Group	2	group 2
Category	P	unidirectional pump
Displacement	51	17
Flange	42	Ø80 GERMAN STANDARDIZED right rotation (with OR)
Shaft	F	CO002 - Tapered 1:5 - ø17.4 - M12x1.5 - key thk.3
Body	IN	inlet - Ø40 a 45° Ø20 M6
	OUT	outlet - Ø35 a 45° Ø15 M6
Cover	A	standard

Technical data table

TYPE	Displacement cm3/rev	Max. Pressure		CODE	
		P1 bar	P3 bar	Left rotation	Right rotation
XV-2P/04	4,20	260	300	X 2 P 41 41 F S R A	X 2 P 41 42 F S R A
XV-2P/06	6,00	260	300	X 2 P 43 41 F S R A	X 2 P 43 42 F S R A
XV-2P/09	8,40	260	300	X 2 P 45 41 F S R A	X 2 P 45 42 F S R A
XV-2P/11	10,80	260	300	X 2 P 47 41 F S R A	X 2 P 47 42 F S R A
XV-2P/14	14,40	250	290	X 2 P 49 41 F S R A	X 2 P 49 42 F S R A
XV-2P/17	16,80	230	270	X 2 P 51 41 F S R A	X 2 P 51 42 F S R A
XV-2P/19	19,20	210	250	X 2 P 53 41 F S R A	X 2 P 53 42 F S R A
XV-2P/22	22,80	200	240	X 2 P 55 41 F S R A	X 2 P 55 42 F S R A
XV-2P/26	26,20	170	210	X 2 P 57 41 F S R A	X 2 P 57 42 F S R A
XV-2P/30	30,00	160	200	X 2 P 59 41 F S S A	X 2 P 59 42 F S S A
XV-2P/34	34,20	150	190	X 2 P 61 41 F S S A	X 2 P 61 42 F S S A
XV-2P/40	39,60	140	180	X 2 P 63 41 F S S A	X 2 P 63 42 F S S A

P1) Max. working pressure - P3) Max. peak pressure

For heavy-duty applications, it is recommended to check the admissible torque of the shaft

Dimensions table

TYPE	Weight kg	A	B	C	D	E	F	D	E	F
		mm	mm	mm	IN			OUT		
XV-2P/04	2,330	89,7	41,1	79,7	ø20	40	M6x1	ø15	35	M6x1
XV-2P/06	2,430	92,7	41,1	82,7	ø20	40	M6x2	ø15	35	M6x1
XV-2P/09	2,530	96,7	43,1	86,7	ø20	40	M6x3	ø15	35	M6x1
XV-2P/11	2,630	100,7	47,5	90,7	ø20	40	M6x4	ø15	35	M6x1
XV-2P/14	2,730	106,7	47,5	96,7	ø20	40	M6x5	ø15	35	M6x1
XV-2P/17	2,830	110,7	47,5	100,7	ø20	40	M6x6	ø15	35	M6x1
XV-2P/19	2,930	114,7	47,5	104,7	ø20	40	M6x7	ø15	35	M6x1
XV-2P/22	3,180	120,7	55,0	110,7	ø20	40	M6x8	ø15	35	M6x1
XV-2P/26	3,280	124,7	55,0	114,7	ø20	40	M6x9	ø15	35	M6x1
XV-2P/30	3,530	132,7	63,2	122,7	ø20	40	M6x10	ø20	40	M6x1
XV-2P/34	3,730	139,7	63,2	129,7	ø20	40	M6x11	ø20	40	M6x1
XV-2P/40	3,930	148,7	63,2	138,7	ø20	40	M6x12	ø20	40	M6x1

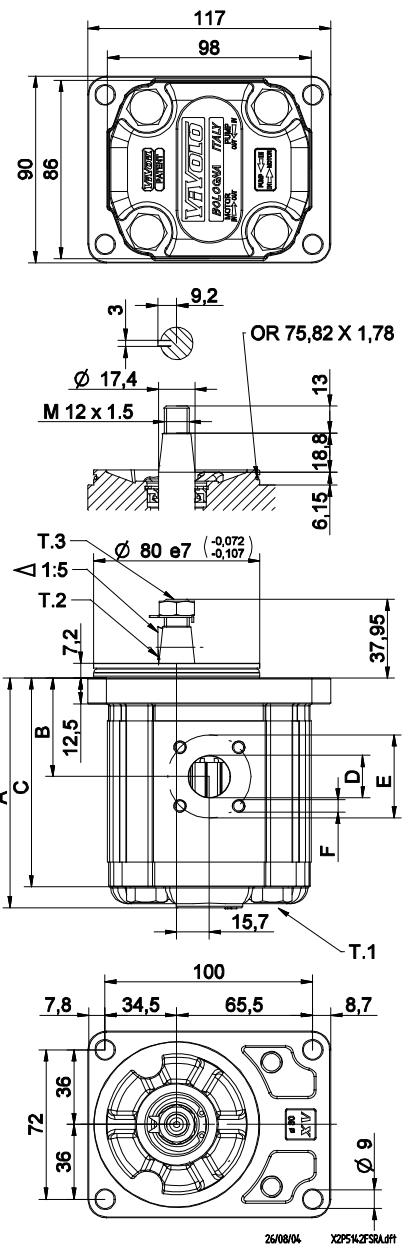

T.1 = 54÷58.9 [Nm] - screw tightening torque M10

T.3 = 40 [Nm] - torque wrench setting 19

T.2 = 233.2 [Nm] - admissible shaft torque (N.B. When choosing a shaft, always check the admissible torque).

Table of variations

XV-2P

ø80 FLANGE

ø80 FLANGE		Shaft		Cover	
Left rotation	Right rotation			Left rotation	Right rotation
		CI001 - Parallel T.2 = 44.1 [Nm] 	CI002 - Parallel T.2 = 67.5 [Nm] 		
41	42	A	B	A	A
		CO001 - Tapered T.2 = 233.2 [Nm] 	CO002 - Tapered T.2 = 233.2 [Nm] 		
		E	F	B	B
		SCF03 - Splined T.2 = 86.1 [Nm] 			
		H		C	C
				D	D
				N	N
				O	O

Displacement	
TYPE	CODE
XV-2P/04	41
XV-2P/06	43
XV-2P/09	45
XV-2P/11	47
XV-2P/14	49
XV-2P/17	51
XV-2P/19	53
XV-2P/22	55
XV-2P/26	57
XV-2P/30	59
XV-2P/34	61
XV-2P/40	63

Standard bodies						
Displacement cm ³ /rev	Standard threads					
	04	O - O	S - R	B - B	L - M	Z - Z
06	O - O	S - R	B - B	L - M	Z - Z	Z - Z
09	O - O	S - R	B - B	L - M	Z - Z	Z - Z
11	O - O	S - R	B - B	L - M	Z - Z	Z - Z
14	P - O	S - R	C - B	L - M	Z - Z	Z - Z
17	P - O	S - R	C - B	L - M	Z - Z	Z - Z
19	P - O	S - R	C - B	L - M	Z - Z	Z - Z
22	P - O	S - R	C - B	L - M	Z - Z	Z - Z
26	Q - P	S - R	D - C	L - M	Z - Z	Z - Z
30	Q - P	S - S	D - C	L - M	Z - Z	Z - Z
34	Q - P	S - S	D - C	L - M	Z - Z	Z - Z
40	Q - P	S - S	D - C	L - M	Z - Z	Z - Z

Table showing standard flange and thread combinations available in stock

Body (threads/flanges)													
	A		B		C		D		E		F		G
	H		I		L		M		N		O		P
	Q		R		S		T		U		V		Z

unidirectional pump - series XV

XV-2P

"SAE A" TYPE PUMP
 ø82.5 FLANGE - SPLINED SHAFT

X 2 P 51 52 I S R A

Series	X	series XV
Group	2	group 2
Category	P	unidirectional pump
Displacement	51	17
Flange	52	Ø82.5 SAE A right rotation (with OR)
Shaft	I	SCF04 - Splined ø15.456 z=9, H=22.5 - SAE J498 9T 16/32DP
Body	IN	inlet - Ø40 a 45° Ø20 M6
	OUT	outlet - Ø35 a 45° Ø15 M6
Cover	A	standard

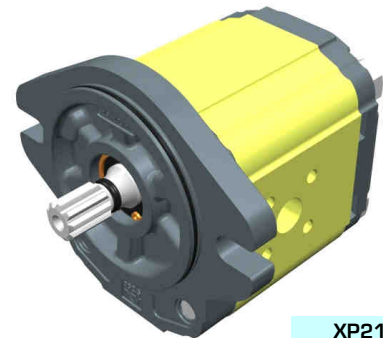

XP219

Technical data table

TYPE	Displacement cm3/rev	Max. Pressure		CODE	
		P1 bar	P3 bar	Left rotation	Right rotation
XV-2P/04	4,20	260	300	X 2 P 41 51 I S R A	X 2 P 41 52 I S R A
XV-2P/06	6,00	260	300	X 2 P 43 51 I S R A	X 2 P 43 52 I S R A
XV-2P/09	8,40	260	300	X 2 P 45 51 I S R A	X 2 P 45 52 I S R A
XV-2P/11	10,80	260	300	X 2 P 47 51 I S R A	X 2 P 47 52 I S R A
XV-2P/14	14,40	250	290	X 2 P 49 51 I S R A	X 2 P 49 52 I S R A
XV-2P/17	16,80	230	270	X 2 P 51 51 I S R A	X 2 P 51 52 I S R A
XV-2P/19	19,20	210	250	X 2 P 53 51 I S R A	X 2 P 53 52 I S R A
XV-2P/22	22,80	200	240	X 2 P 55 51 I S R A	X 2 P 55 52 I S R A
XV-2P/26	26,20	170	210	X 2 P 57 51 I S R A	X 2 P 57 52 I S R A
XV-2P/30	30,00	160	200	X 2 P 59 51 I S S A	X 2 P 59 52 I S S A
XV-2P/34	34,20	150	190	X 2 P 61 51 I S S A	X 2 P 61 52 I S S A
XV-2P/40	39,60	140	180	X 2 P 63 51 I S S A	X 2 P 63 52 I S S A

P1) Max. working pressure - P3) Max. peak pressure

For heavy-duty applications, it is recommended to check the admissible torque of the shaft

Dimensions table

TYPE	Weight kg	A	B	C	D	E	F	D	E	F
		mm	mm	mm	IN			OUT		
XV-2P/04	2,280	88,0	39,4	78,0	ø20	40	M6x1	ø15	35	M6x1
XV-2P/06	2,380	91,0	39,4	81,0	ø20	40	M6x2	ø15	35	M6x1
XV-2P/09	2,480	95,0	41,4	85,0	ø20	40	M6x3	ø15	35	M6x1
XV-2P/11	2,580	99,0	45,8	89,0	ø20	40	M6x4	ø15	35	M6x1
XV-2P/14	2,780	105,0	45,8	95,0	ø20	40	M6x5	ø15	35	M6x1
XV-2P/17	2,880	109,0	45,8	99,0	ø20	40	M6x6	ø15	35	M6x1
XV-2P/19	2,980	113,0	45,8	103,0	ø20	40	M6x7	ø15	35	M6x1
XV-2P/22	3,130	119,0	53,3	109,0	ø20	40	M6x8	ø15	35	M6x1
XV-2P/26	3,230	123,0	53,3	113,0	ø20	40	M6x9	ø15	35	M6x1
XV-2P/30	3,480	131,0	61,5	121,0	ø20	40	M6x10	ø20	40	M6x1
XV-2P/34	3,680	138,0	61,5	128,0	ø20	40	M6x11	ø20	40	M6x1
XV-2P/40	3,880	147,0	61,5	137,0	ø20	40	M6x12	ø20	40	M6x1

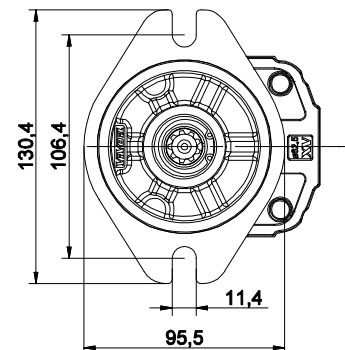
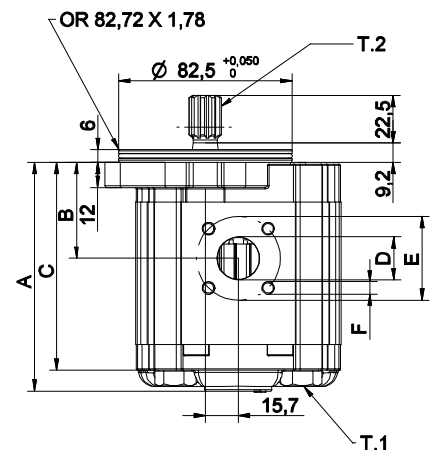
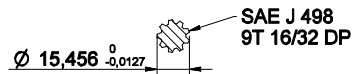
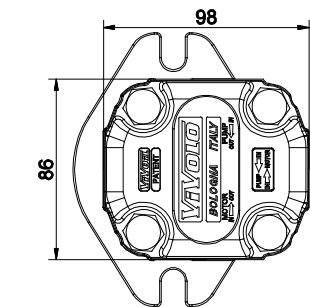

26/06/04 XP2562SRU1ff

T.1 = 54÷58.9 [Nm] - screw tightening torque M10

T.2 = 67.1 [Nm] - admissible shaft torque (N.B. When choosing a shaft, always check the admissible torque).

Table of variations

XV-2P

ø82.5 FLANGE "SAE A"

ø82.5 FLANGE "SAE A"				Shaft				Cover			
Left rotation		Right rotation		Left rotation		Right rotation		Left rotation		Right rotation	
	51		52	CI001 - Parallel T.2 = 44.1 [Nm]	A	CI002 - Parallel T.2 = 67.5 [Nm]	B				A
	53		54	CO001 - Tapered T.2 = 233.2 [Nm]	E	CO002 - Tapered T.2 = 233.2 [Nm]	F				B
Without OR		Without OR		SCF04 - Splined T.2 = 67.1 [Nm]	I						C
											D
											N
											O

Displacement		Standard bodies						
TYPE	CODE	Displacement cm ³ /rev	Standard threads					
XV-2P/04	41	04	O - O	S - R	B - B	L - M	Z - Z	
XV-2P/06	43	06	O - O	S - R	B - B	L - M	Z - Z	
XV-2P/09	45	09	O - O	S - R	B - B	L - M	Z - Z	
XV-2P/11	47	11	O - O	S - R	B - B	L - M	Z - Z	
XV-2P/14	49	14	P - O	S - R	C - B	L - M	Z - Z	
XV-2P/17	51	17	P - O	S - R	C - B	L - M	Z - Z	
XV-2P/19	53	19	P - O	S - R	C - B	L - M	Z - Z	
XV-2P/22	55	22	P - O	S - R	C - B	L - M	Z - Z	
XV-2P/26	57	26	Q - P	S - R	D - C	L - M	Z - Z	
XV-2P/30	59	30	Q - P	S - S	D - C	L - M	Z - Z	
XV-2P/34	61	34	Q - P	S - S	D - C	L - M	Z - Z	
XV-2P/40	63	40	Q - P	S - S	D - C	L - M	Z - Z	

Table showing standard flange and thread combinations available in stock

Body (threads/flanges)													
	A		B		C		D		E		F		G
	H		I		L		M		N		O		P
	Q		R		S		T		U		V	Gehäuse Geschlossen Z	

DOUBLE SHAFT - Variant VA

All versions may be supplied with a double shaft using all types of shafts and flanges
As per catalogue

Example of order code

Standard -----X0P0602ABBA
With double shaft -----X0P0602ABBA **VA**

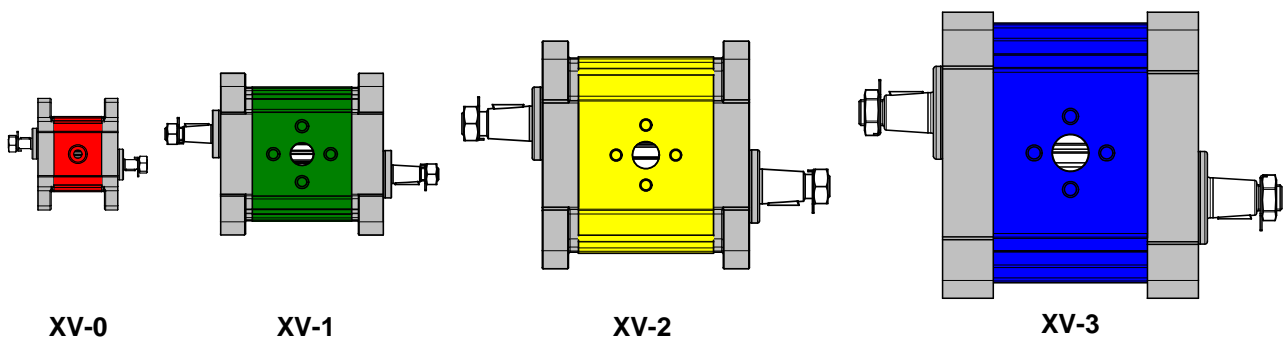

SEALS made of FKM (viton) variant VITON

All versions may be supplied with **FKM (viton)** seals

Example of order code

Standard-----X0P0602ABBA
With FKM (viton) seals -----X0P0602ABBA **VITON**

O-RINGS

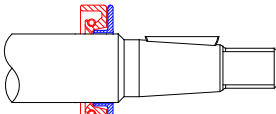
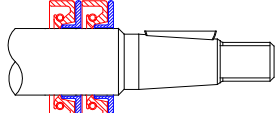
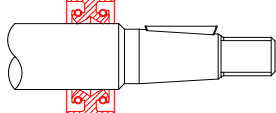
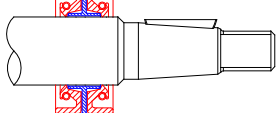
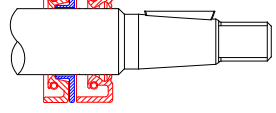
Variant VDC		Oil seal with backup washer (standard for motors)
Variant VDCX		Double oil seal with double backup washer
Variant VDB		DUPLEX oil seal
Variant VDBX		Double opposed oil seal with backup washer
Variant VDCO		Motor Oil Seal with backup washer + Standard Oil Seal

Example of order code

Standard-----X1P0602FIIA
With oil seal and retaining washer -----X1P0602FIIA **VDC**

Pressure-relief valve VM25 for XV0 series

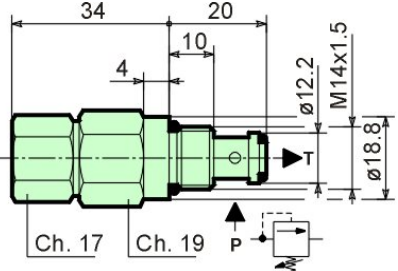
	Technical specifications	
	Capacity	25 l/min
	Max pressure in P	315 bars
	Max pressure in T	315 bars
	Setting range of spring Type 01	20-140 bars
	Setting range of spring Type 02	70-315 bars
	Required filtration	10-15 µm
	Oil viscosity range	2.8-350 cSt
	Recommended oil temperature	-20 + 80 °C
	Seal material	Buna N
	Weight	0.110 kg
	Pressures with flow of 1 l/min: opening value in relation to setting	95%
	Closing value in relation to setting	75%
	Hydraulic oil	HM, HV ISO 6074

Pressure-relief valve VM50 for XV1 and XV2 series

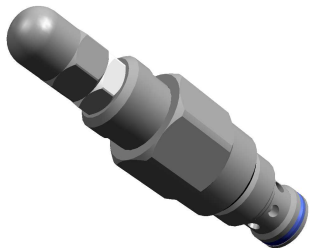
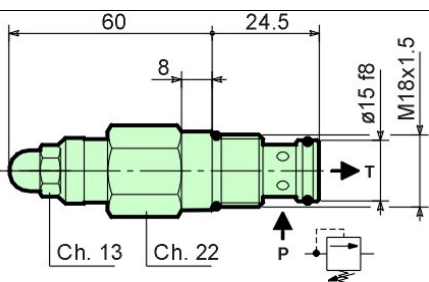
	Technical specifications	
	Capacity	50/min
	Max pressure in P	350 bars
	Max pressure in T	350 bars
	Setting range of spring Type 01	10-105 bars
	Setting range of spring Type 02	70-210 bars
	Setting range of spring Type 03	140-350 bars
	Required filtration	10-15 µm
	Oil viscosity range	2.8-350 cSt
	Recommended oil temperature	-20 + 80 °C
	Seal material	Buna N
	Weight	0.125 kg
	Pressures with flow of 1 l/min: opening value in relation to setting	95%
	Closing value in relation to setting	75%
	Hydraulic oil	HM, HV ISO 6074

Standard test settings

TYPE	Pressure (bars)	Capacity (l/min)	Pressure increase (bars x turn of screw)
1 (10-105 bars)	50	5	15
2 (70-210 bars)	130	5	32
3 (140-350 bars)	200	5	67

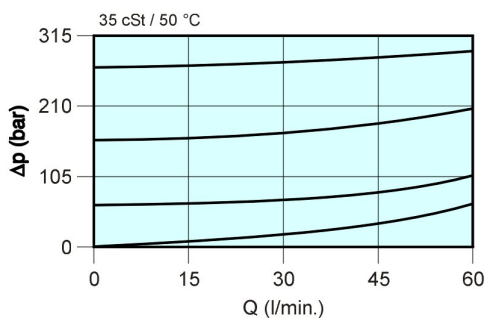

Performance of VM25 and VM50 valves

Δp = Pressure drop in bars

Q = Capacity in litres per minute

90° STEEL ELBOWS

Code	Type	A	B	C	D	E	F	G	OR	V	weigth
									O ring	Screw	
8KRG001	RG 26/12-3/8"BSP	3/8"	26	5,5	12	18	9,5	27	ø14,00x1,78	M5x18	0,13
8KRG002	RG 26/12-1/2"BSP	1/2"	26	5,5	12	18	9,5	27	ø14,00x1,78	M5x18	0,12
8KRG003	RG 30/13,5 -3/8"BSP	3/8"	30	6,5	13,5	18	9,5	27	ø15,88x2,62	M6x20	0,17
8KRG004	RG 30/13,5 -1/2"BSP	1/2"	30	6,5	13,5	18	9,5	27	ø15,88x2,62	M6x20	0,16
8KRG005	RG 40/20-1/2"BSP	1/2"	40	8,5	20	21	10,5	38	ø23,81x2,62	M8x25	0,36
8KRG006	RG 40/20-3/4"BSP	3/4"	40	8,5	20	21	10,5	38	ø23,81x2,62	M8x25	0,32
8KRG007	RG 40/23-3/4"BSP	3/4"	40	8,5	23,5	21	10,5	38	ø25,12x1,78	M8x25	0,29
8KRG008	RG 51/27-1"BSP	1"	51	10,5	27	27	13,5	47	ø31,42x2,62	M10x30	0,7
8KRG009	RG 51/27-3/4" BSP	3/4"	51	10,5	27	27	13,5	47	ø31,42x2,62	M10x30	0,7
8KRG011	RG 56/34-3/4" BSP	3/4"	56	10,5	34	27	13,5	47	ø37,77x2,62	M10x30	0,72
8KRG012	RG 62/36-1"1/4 BSP	1"1/4	62	10,5	36	36	19	56	ø41,28x3,53	M10x30	0,94
8KRG015	RG 62/36-1"1/4 BSP M12	1"1/4	62	12,5	36	36	19	56	ø41,28x3,53	M12x35	0,94
8KRG013	RG 72,5/45-1"1/2 BSP	1"1/2	72,5	12,5	45	38	16	58	ø49,20x3,53	M12x35	1,23
8KRG014	RG 92/65-2" BSP	2	92	12,5	65	50	21	75	ø69,85x3,53	M12x40	1,65

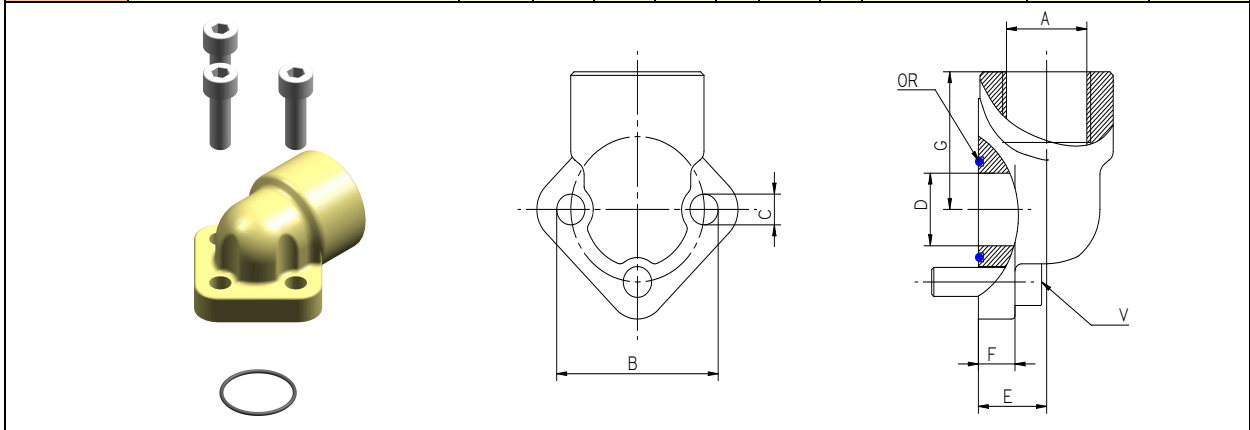

STRAIGHT STEEL UNIONS

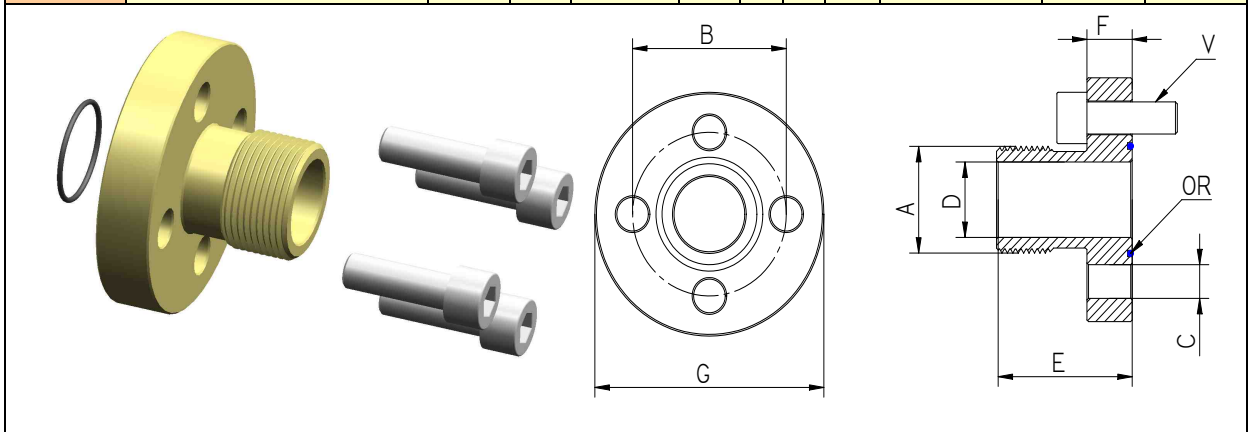
Code	Type	A	B	C	D	E	F	G	OR	V	Weigth
									O ring	Screw	
8KRD001	RD 26/12-3/8"BSP	3/8"	26	5,5	12	32	10	39	ø14,00x1,78	M5x18	0,11
8KRD002	RD 30/13,5-1/2"BSP	1/2"	30	6,5	13,5	40	10	44	ø15,88x2,62	M6x20	0,14
8KRD005	RD 40/20-3/4"BSP	3/4"	40	8,5	20	42	12	51	ø23,81x2,62	M8x25	0,3
8KRD006	RD 40/23,5-3/4"BSP	3/4"	40	8,5	23,5	42	12	51	ø25,12x1,78	M8x25	0,29
8KRD007	RD 51/27-1"BSP	1"	51	10,5	27	43	12	68	ø31,42x2,62	M10x25	0,46
8KRD008	RD 56/34-1"1/4 BSP	1" 1/4	56	10,5	34	53	12	73	ø37,77x2,62	M10x25	0,68
8KRD009	RD 62/36-1"1/4 BSP	1" 1/4	62	10,5	36	47	13	78	ø41,28x3,53	M10x25	0,9
8KRD010	RD 72,5/45-1"1/2 BSP	1" 1/2	72,5	12,5	45	49	14	89	ø49,20x3,53	M12x30	1,05
8KRD011	RD 92/65-2"1/2 BSP	2" 1/2	92	12,5	65	60	18	114	ø69,85x3,53	M12x40	1,15

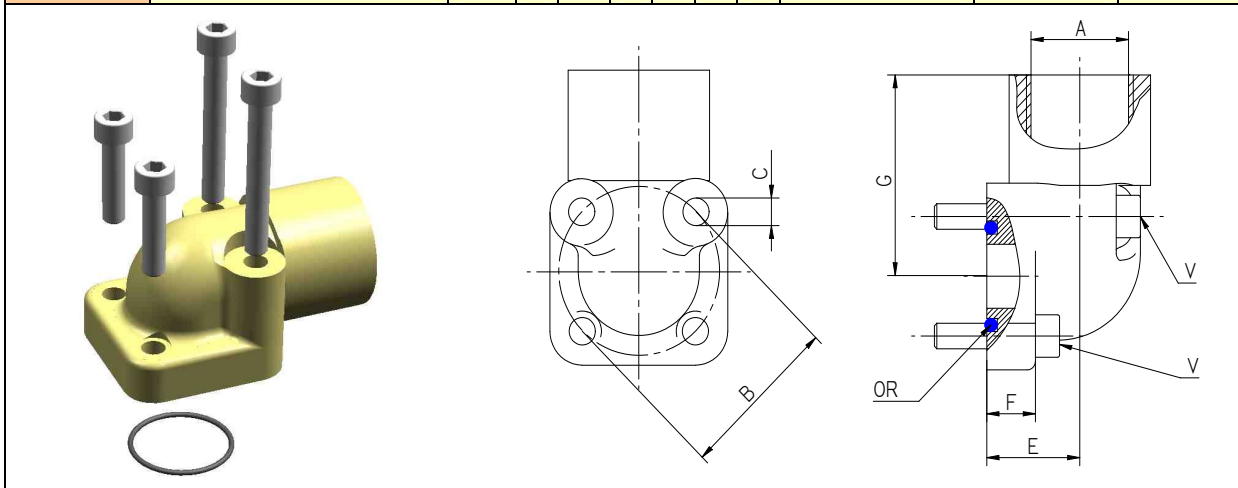

SQUARED STEEL ELBOWS

Code	Type	A	B	C	D	E	F	G	OR	V	Weight
									O ring	Screw	
8KRQ001	RQ 30/12-3/8"BSP	3/8"	30	6,5	12	19	11	41	ø15,88x2,61	Nº2 M6x20 Nº2 M6x35	0,29
8KRQ002	RQ 30/12-1/2"BSP	1/2"	30	6,5	12	19	11	41	ø15,88x2,62	Nº2 M6x20 Nº2 M6x35	0,29
8KRQ003	RQ 35/15 -3/8"BSP	3/8"	35	6,5	15	18	11	40	ø18,72x2,62	Nº2 M6x20 Nº2 M6x35	0,34
8KRQ004	RQ 35/15 -1/2"BSP	1/2"	35	6,5	15	18	11	40	ø18,72x2,62	Nº2 M6x20 Nº2 M6x35	0,34
8KRQ005	RQ 40/20-1/2"BSP	1/2"	40	6,5	20	24	10	45	ø22,22x2,62	Nº2 M6x25 Nº2 M6x45	0,4
8KRQ006	RQ 40/20-3/4"BSP	3/4"	40	6,5	20	24	10	45	ø22,22x2,62	Nº2 M6x25 Nº2 M6x45	0,4
8KRQ007	RQ 55/25-3/4"BSP	3/4"	55	8,5	25	35	13	54	ø29,75x3,53	Nº2 M8x25 Nº2 M8x60	0,45
8KRQ008	RQ 55/25-1" BSP	1"	55	8,5	25	35	13	54	ø29,75x3,53	Nº2 M8x25 Nº2 M8x60	0,45

STRAIGHT STEEL UNIONS

Code	Type	A	B	C	D	E	F	G	OR	V	Weight
									O ring	Screw	
8KRD003	RD 35/15 (BH)-1/2"BSP	1/2"	35	6,5	14	35	10	40	ø18,72x2,62	M6x20	0,15
8KRD004	RD 40/20 (BH)-3/4"BSP	3/4"	40	6,5	17	35	10	40	ø22,22x2,62	M6x20	0,17

