

Product datasheet

Dock shelter

ASSA ABLOY DS6060S

ASSA ABLOY

ASSA ABLOY Entrance Systems

The global leader in
door opening solutions



Copyright and Disclaimer Notice

Although the contents of this publication have been compiled with the greatest possible care, ASSA ABLOY Entrance Systems cannot accept liability for any damage that might arise from errors or omissions in this publication. We also reserve the right to make appropriate technical modifications/replacements without prior notice.

No rights can be derived from the contents of this document.

Color guides: Color differences may occur due to different printing and publication methods.

No part of this publication may be copied or published by means of scanning, printing, photocopying, microfilm or any other process whatsoever without prior permission in writing by ASSA ABLOY Entrance Systems.

Copyright © ASSA ABLOY Entrance Systems AB 2006-2017.

All rights reserved.

ASSA ABLOY, Besam, Crawford, Albany and Megadoor as words and logo are trademarks belonging to the ASSA ABLOY Group

Technical facts

Features

Sizes – nominal height	3280, 3480, 3680 mm
Sizes – nominal width	3250, 3450 mm
Sizes - nominal depth	600 mm, 900 mm
Size – top curtain	1000 mm
Curtain colour	Black
Parking guides	White
Wall fixings	Concrete, sandwich, light concrete, loadhouse, cavity, insulated panel

Performance

Top and side curtains

Double layer high quality polyester:	
Thickness:	3.0 mm
Coating:	Front and back
Weight:	Approx. 3400g/m ²
Flammability:	DIN 75200
Tensile strength:	DIN 53354 <ul style="list-style-type: none">• Longitudal: 2700N/5cm• Transverse: 2300N/5cm
Tear elongation:	DIN 53363 <ul style="list-style-type: none">• Longitudal: 300 N• Transverse: 250 N

Continuous roof cover

One layer high quality polyester:	
Thickness:	0.5 mm
Coating:	Front and back
Total weight:	Approx. 680 g/m ²
Flammability:	DIN 75200
Tensile strength:	DIN 53354 <ul style="list-style-type: none">• Longitudal: 2700N/5cm• Transverse: 2300N/5cm
Tear elongation:	DIN 53363 <ul style="list-style-type: none">• Longitudal: 300 N• Transverse: 250 N

Steel frame

Surface treatment Z350:	Galvanized 25µm; Corrosive Category C3 M acc. DIN EN ISO 12944-2
-------------------------	---

Contents

Copyright and Disclaimer Notice	2
Technical facts	3
Contents	4
1. Description	5
1.1 Application	5
1.2 Mode of operation	5
1.3 Overview	5
1.4 Standard	5
1.5 Options	5
1.6 Description of available options	6
2. Selection Guide	7
2.1 Installation height	7
2.2 Top curtain length	7
2.3 Free space above	7
2.4 Nominal depth	7
2.5 Example	7
3. Specifications	8
3.1 Dimensions	8
3.2 Construction	8
3.3 Corrosive Category	8
4. Building and space requirements	9
4.1 Fixing points	9
4.2 Wall fixings	9
4.2.1 Concrete wall	9
4.2.2 Light concrete wall	9
4.2.3 Cavity wall	9
4.2.4 Insulated wall	10
5. Service	11
Index	12

1. Description

1.1 Application

The ASSA ABLOY DS6060S curtain dock shelter steel is the standard solution for energy saving oriented operators. The vehicle reverses into the dock shelter which seals it off with flexible side and top curtains, giving weather protection during the loading and unloading process. The result is an improved working environment and goods protection. The curtain material has a very high wear and tear resistance. The ASSA ABLOY DS6060S curtain dock shelter steel is designed for wall installation and standard single or multi Loadhouses.

1.2 Mode of operation

The sides and the roof push back under impact when vehicles dock inaccurately, whereby the roof rises automatically. Damages to vehicles and to the shelter are virtually eliminated. The front frame holds the curtain material which has a double woven textile reinforcement. The top curtain has a slit in the main wear area. The dock shelter supply includes for all fixing materials and sealant.

1.3 Overview

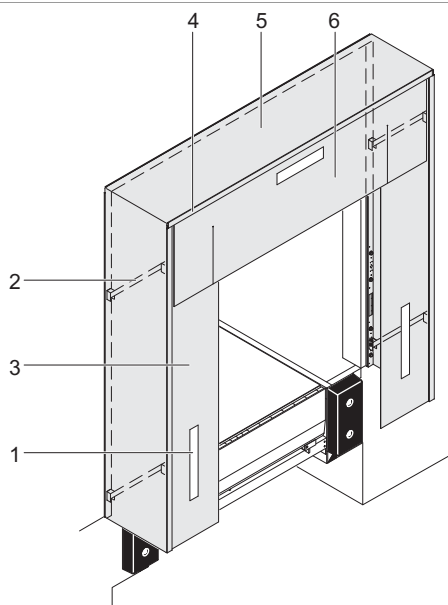

- 1) White parking guides
- 2) Bracing arms
- 3) Side curtains
- 4) Cold rolled steel profile
- 5) Continuous roof cover
- 6) Split top curtain

1.4 Standard

Nominal height	3280, 3480, 3680 mm
Nominal width	3250, 3450 mm
Side curtain	600 mm for NW = 3250 mm 700 mm for NW = 3450 mm
Top curtain	1000 mm
Nominal depth	600 mm
Curtain color and material	Black PVC fabric
Parking guides	white

1.5 Options

Nominal depth	900 mm
Top part	rain channel
Top curtain	digit on top curtain
Side curtain	notching on both sides
Wall fixings	Concrete, sandwich, light concrete, loadhouse, cavity, insulated panel
Corner seals	triangle or round cushions in lower corners of the dock shelter.

1.6 Description of available options

Standard options for improved working conditions and less draught into the building.

A: Rain Channel

The unique channel is integrated in the middle of the roof part.

- Controlled water drainage

The water is led out left and right, not into the loading area

B: Digit on top curtain

300 mm high letters or numbers printed in the middle of the top curtain.

Individual customised marking of loading bays

C: Corner seals

Triangle or round cushions covered with PVC curtain material in lower corners of the dock shelter.

Minimization of draught from below during loading and unloading

D: Notching on both sides

From factory a square of the lower corner front curtain is cut out.

- Avoid damaged front curtains due to the collision between vehicle and buffer.

Recommended in combination with min. 140 mm deep buffers, like RB, EBH, EBF or steel spring buffer.

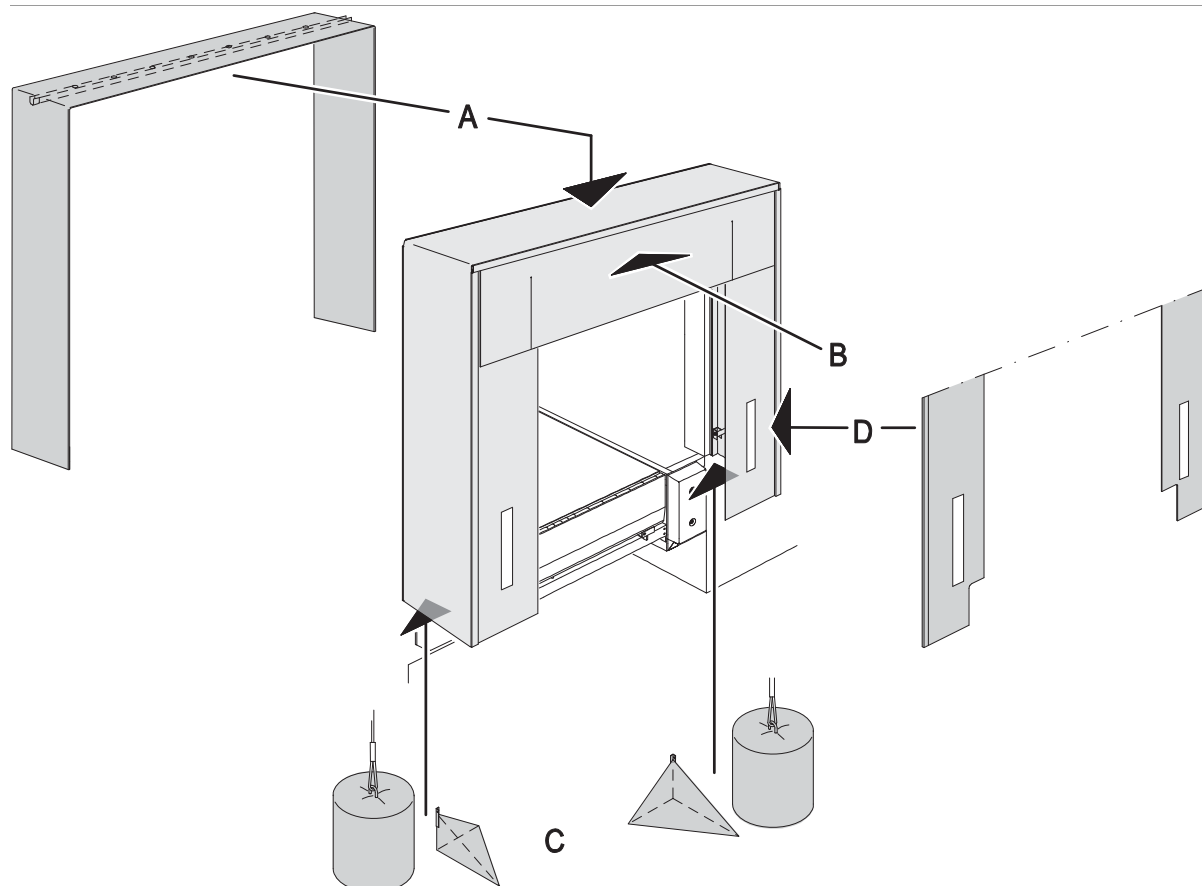

2. Selection Guide

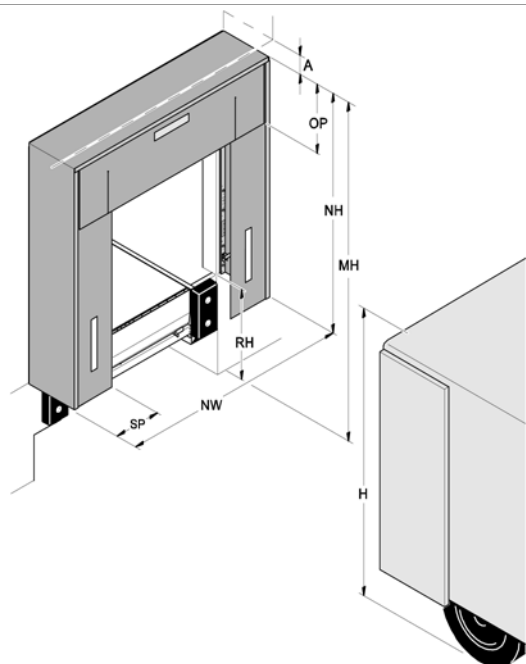

2.1 Installation height

The installation height [MH] should be minimum 250 mm above the truck [H] to secure that the pressure is not too big on the complete top part of the shelter and in order to avoid damages or bad functionality.

2.2 Top curtain length

The length of the top curtain [OP] should be minimum 200 mm overlapping the truck in order to secure a good sealing effect.

2.3 Free space above

The minimum free space above the shelter [A] must not be less than $NT/2 - 100$.

2.4 Nominal depth

The nominal depth [NT] depends on the slope in front of the building [α] and the height of the truck [H]. To make sure that the truck is sealed completely NT should be bigger than $\alpha * H$.

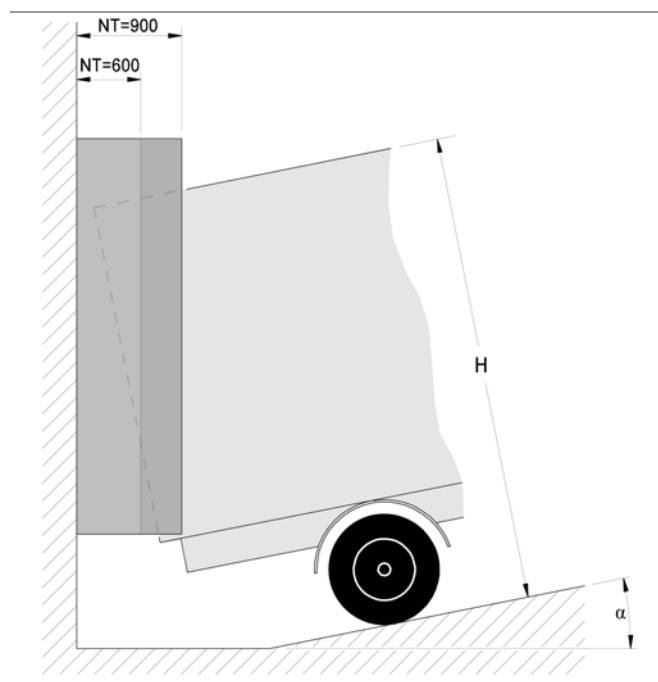

2.5 Example

$MH = 4500\text{mm}$
 $OP = 1000\text{mm}$
 $H_{\text{max}} = MH - 250\text{mm}$
 $H_{\text{min}} = MH - OP + 200\text{mm}$
 $\alpha = 16\% (\sim 9^\circ)$
 $H_{\text{max}} = 4500\text{mm} - 250\text{mm} = 4250\text{mm}$
 $NT1 = \alpha * H_{\text{max}} = 0,16 * 4250 = 680 \rightarrow NT 900$
 $A1_{\text{min}} = 900/2 - 100 = 350\text{mm}$
 $H_{\text{min}} = 4500\text{mm} - 1000\text{mm} + 200\text{mm} = 3700\text{mm}$
 $NT2 = \alpha * H_{\text{min}} = 0,16 * 3700 = 592 \rightarrow NT 600$
 $A2_{\text{min}} = 600/2 - 100 = 200\text{mm}$

3. Specifications

3.1 Dimensions



Abb.	Dimension	Value (mm)
NW	Nominal width	3250, 3450 mm
NH	Nominal height	3280, 3480, 3680 mm
OP	Length of top curtain	1000 mm
SP	Width of side curtain	600, 700 mm
MH	Installation height	4500 (recommended)
NT	Nominal depth	600 mm, 900 mm
RH	Ramp height	

3.2 Construction

The ASSA ABLOY DS6060S curtain dock shelter steel consists of a front and rear frame made of steel profiles which are connected to each other by bracing arms. The frame construction is covered on top and down the sides by a continuous textile reinforced cladding material.

3.3 Corrosive Category

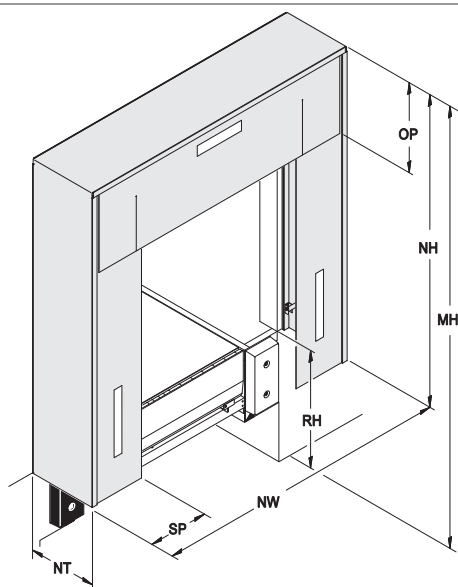
The DS6060S curtain dock shelter steel is suitable for the following environments, up to Corrosive Category C3 M:

- Atmospheres with low level of pollution; mostly rural areas.
- Urban and industrial atmospheres, moderate sulphur dioxide pollution.
- Coastal areas with low salinity.

The DS6060S curtain dock shelter steel is NOT suitable for the following environments (C4 & C5-I M):

- Industrial areas and coastal areas with moderate salinity.
- Industrial areas with high humidity and aggressive atmosphere.
- Coastal and offshore areas with high salinity.

For these environments our DS6060E or DS6060P dock shelters with aluminium profiles are suitable.

4. Building and space requirements

4.1 Fixing points

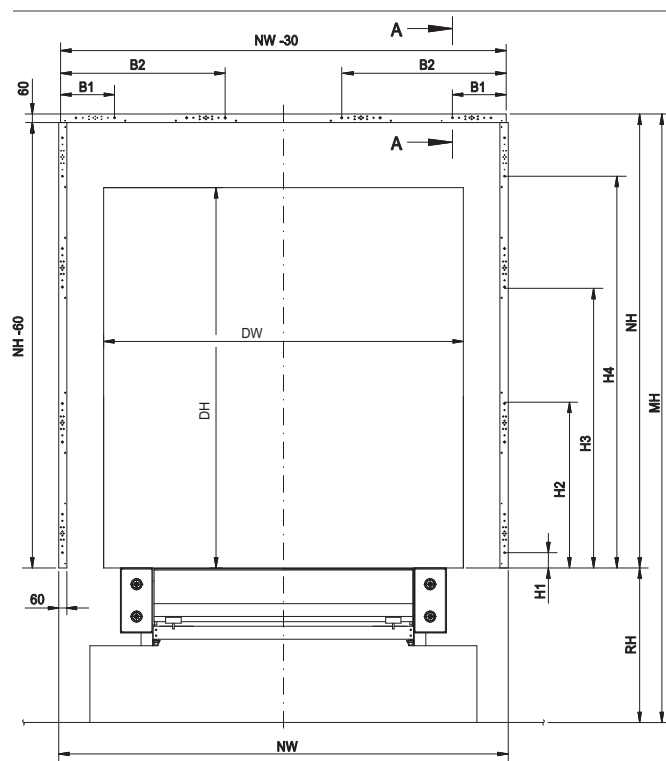

- NH Nominal height
- NW Nominal width
- MH Installation height
- RH Dock height
- DW Door width
- DH Door height

NW	NH	B1	B2	H1	H2	H3	H4
3250 / 3450	3280	389	1189	111	1189	2031	2831
3250 / 3450	3480	389	1189	111	1189	2231	3031
3250 / 3450	3680	389	1189	111	1189	2431	3231

4.2 Wall fixings

4.2.1 Concrete wall

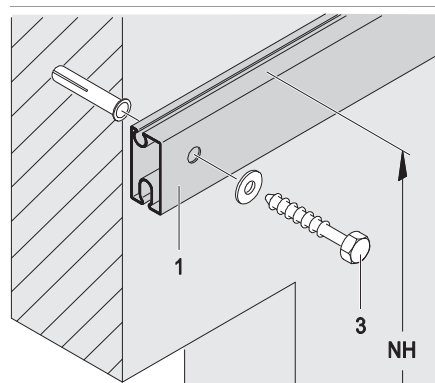

4.2.2 Light concrete wall

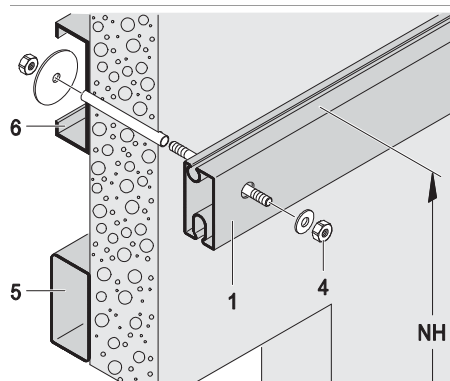

4.2.3 Cavity wall

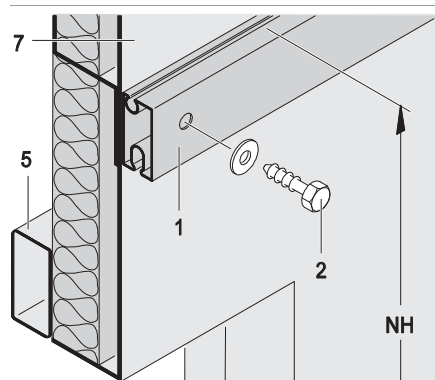

4.2.4 Insulated wall

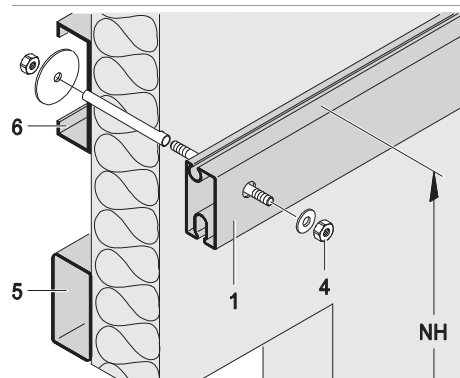

1	Cold rolled steel profile
2	Self-tapping screw
3	Expansion bolt
4	Threaded bolt with nut, washer and spacer tube
5	Door mounting frame rectangular 80x40x2*
6	Mounting frame for dock shelter 120x40x15x3*
7	Sheet metal 3 mm thick*

* not included in delivery

5. Service

Preventive Maintenance Program and Modernization Services

As your entrances are part of your business flow, there's every reason to keep them working well. ASSA ABLOY Entrance Systems offers you a maintenance and modernization expertise to rely on. Our Maintenance Programs and Modernization Services are backed by a extensive expertise for all types of industrial door and docking systems, independent of brand. At your disposal is a team of dedicated expert technicians, proven through decades of maintenance, service and satisfied customers.

Preventive Maintenance Programs

Minimizing lost time, lost energy and unexpected hassle is our team's constant objective. Our service organization can support you 24/7 in maintaining all industrial door and docking systems, independent of brand. If you want to be one step ahead of break-downs, explore our portfolio of Pro-Active Care plans. Naturally, we also offer entrance upgrades to suit your specific wishes and business needs.

Pro-Active Care - Maintenance plans to fit your business

Regular maintenance can extend the lifetime of your equipment and help prevent unexpected problems. Our technician arrives on-site equipped with the knowledge and tools to service all automatic entrances, independent of brand.

- **Pro-Active Bronze**

The base on which all Pro-Active Plans are built provides the security of knowing that your equipment is regularly inspected and certified for safety, as well as performing optimally. It includes a number of planned on-site visits depending on your needs. Any unplanned service calls required during the term of the contract (including labor, travel and parts) are billed at special Pro-Active Care prices.

- **Pro-Active Silver**

This plan provides all the benefits of Pro-Active Bronze with the added advantage of labor and travel being included for service calls during regular business hours. The only additional charge would be for any parts that may be needed throughout the term of the contract.

- **Pro-Active Gold**

This plan provides the ultimate protection for your automatic entrance investment. It includes all the benefits of Pro-Active Silver, plus replacement of any parts required during an unplanned repair or planned maintenance visit. Pro-Active Gold is an excellent way to budget your automatic door expenses annually.

- **Pro-Active Tailor-Flex**

Our most flexible maintenance and service offering. The Pro-Active Care plan is designed by you, our customer. The plan allows you to balance your maintenance expenses against your real-world budget and presents the option to add or delete a number of maintenance elements to suit your budget goals, while meeting your overall performance and safety needs.

Modernization

Your entrances are a long-term investment, from which you always want the best. Products develop over time, so do regulations and your business. Let us help you increase energy savings and meet today's standards. We provide advice and modernization kits for outdated installations, ensuring your investment meet requirements and performs optimally for many more years to come.

Re-Active Service		Pro-Active Care				
		Pro-Active Bronze	Pro-Active Silver	Pro-Active Gold	Pro-Active Tailor Flex	
		○	○	○	●	Other customized requests such as Response Time, Performance InfoPack and Advanced User Training
		○	○	●	○	Replacement of worn parts according to preventive Consumable Exchange Program
		○	○	●	○	Replacement of spare parts on breakdowns
		○	●	●	○	Travel and labor for additional call-out visits
		●	●	●	●	Preventive maintenance visits 1-4 times per year
		●	●	●	●	Travel and labor for preventive maintenance visits
		●	●	●	●	Response time and priority on call-outs <24h
		●	●	●	●	Preventive planned maintenance that meets the most demanding standards in the market
	●	●	●	●	●	Safety and quality checks according to applicable regulations and norms. Documentation of test results provided
●	●	●	●	●	●	Documentation of equipment status, assessment and service provided, all generated on site
●	●	●	●	●	●	Highly trained professional technicians with extensive knowledge, state-of-the-art tools and the right spare parts*
●	●	●	●	●	●	Dedicated Professional Customer Care Hotline

● = Included as standard
 ○ = Available at special prices
 * Well-stocked service vehicles with genuine and new spare parts

Index

A		S	
Application	5	Selection Guide	7
B		Service	11
Building and space requirements	9	Specifications	8
C		Standard	5
Cavity wall	9	Steel frame	3
Concrete wall	9	T	
Construction	8	Technical facts	3
Continuous roof cover	3	Top and side curtains	3
Copyright and Disclaimer Notice	2	Top curtain length	7
Corrosive Category	8	W	
D		Wall fixings	9
Description	5		
Description of available options	6		
Dimensions	8		
E			
Example	7		
F			
Features	3		
Fixing points	9		
Free space above	7		
I			
Installation height	7		
Insulated wall	10		
L			
Light concrete wall	9		
M			
Mode of operation	5		
N			
Nominal depth	7		
O			
Options	5		
Overview	5		
P			
Performance	3		

ASSA ABLOY Entrance Systems is a leading supplier of entrance automation solutions for the efficient flow of goods and people. Building on the long-term success of the Besam, Crawford, Albany and Megadoor brands, we offer our solutions under the ASSA ABLOY brand. Our products and services are dedicated to satisfying end-user needs for safe, secure, convenient and sustainable operations.

ASSA ABLOY Entrance Systems is a division of ASSA ABLOY.

assaabloyentrance.com



ASSA ABLOY Entrance Systems

assaabloyentrance.com