

TECHNICAL SPECIFICATION:

1. All parts of fan should be properly assembled, no oil or dirt on the surface, no obvious distortion, mechanical damage and other defects.
2. Fan rotation is flexible, no delay no operation sound, no scratch and other undesirable phenomena.
3. The safety requirement of fan is performed according to GB12350-2009, the electrical strength is 1500V•min, and the insulation resistance is not less than 100M Ω at room temperature.
4. Motor insulation class, F CLASS.
5. Motor protection level, IP44, fan protection level, IP2X.
6. The fan balance level is: 1400± 10% r/min high G6. 3, vibration value is less than 5.4mm/s.
7. MAER box.
8. Built-in heat protector.

Test data at free:

Connection	UAC (V)±5%	f (Hz)	P1 (W)±10%	I (A)±10%	n (r/min)±10%	Noise db(A)
	3~380V	50	770	1.65	1400	77

Performance parameters at key point:

	psf (pa)	I (A)	P1 (W)	n (r/min)	Q (m³/h)	Note
①	0	1.48	705	1414	11304	
②	83	1.63	834	1395	9891	
③	155	1.75	937	1378	7804	MAX EFF.
④	249	1.98	1120	1346	4069	

PS: Fan working performance tested with MAER wall plate, and under standard atmospheric pressure at 20°C

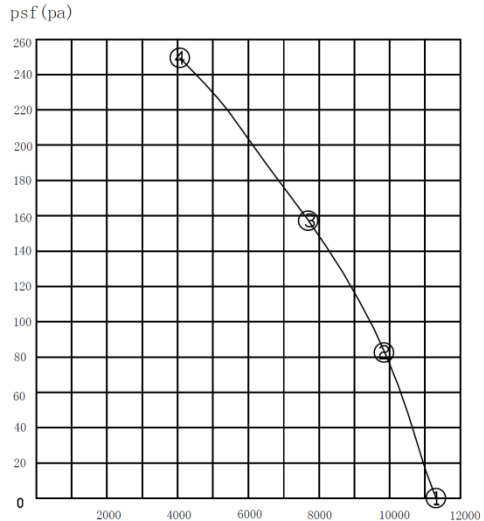

WIRING DIAGRAM

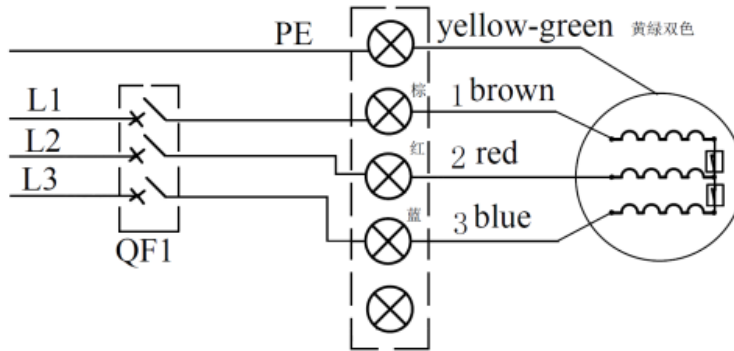

	Product model	YSWF102L70P4-753N-630S
	Product type	External rotor axial flow fan
	Customer	乌克兰 (Ukraine)
	Product number	MAER – 150301D
	Certification	CE, CCC

Condition of use:

- 1) Voltage and frequency: 3 ~ 380V + 5% (50 Hz)
- 2) Qualification requirements: Terminal block, the recommended standard of lead wire is not less than 0,75mm².
- 3) Installation position: vertical or upward.
- 4) Ambient temperature: -40 ~ 70°C.

THE EXTERNAL WIRING DIAGRAM:

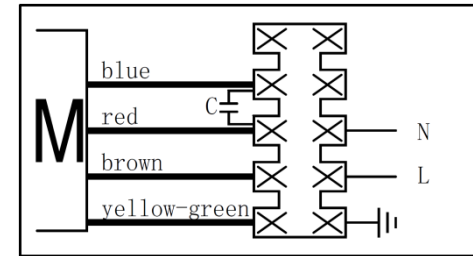

MARK

MAER AXIAL FAN MOTOR
MOTORS & FANS

MODEL: **YSWF102L70P4-753N-630 SUCTION 4D-630-S**

VOLTAGE: 380V / 50Hz

N.W/G.W. 16.3/18.9 kg

MEAS: 67.5x67.5x24 cm

CL. F WITH TERMINAL BOX

20180509X

Nameplate:

YSWF102L70P4-753N-630 S 3~380V50Hz 20μF / 450V
937W 1.75A 1378r/min @ 155Pa
CL. F IP54 2018/05

Tel:+380678807231, +380500679006
web:www.iceteco.com
e-mail: iceteko@gmail.com

АЙСТЕКО
РЕШЕНИЕ ХОЛОВА
WWW.ICETECO.COM

		The signature	(date)(month)(year)	ZHEJIANG MAER FAN MOTOR CO., LTD.
state	Deliver before After the confirmation			
drawing				Product Specification
audit				
approval				