

TECHNICAL SPECIFICATION:

1. All parts of fan should be properly assembled, no oil or dirt on the surface, no obvious distortion, mechanical damage and other defects.
2. Fan rotation is flexible, no delay no operation sound, no scratch and other undesirable phenomena.
3. The safety requirement of fan is performed according to GB12350-2009, the electrical strength is 1500V•min, and the insulation resistance is not less than 100M Ω at room temperature.
4. Motor insulation class, F CLASS.
5. Motor protection level, IP44, fan protection level, IP2X.
6. The fan balance level is: 2700± 10% r/min high G6. 3, vibration value is less than 5.4mm/s.
7. MAER box.
8. Built-in heat protector.

Test data at free:

| Connection | UAC (V)±5% | f (Hz) | P1 (W)±10% | I (A)±10% | n (r/min)±10% | Noise db(A) |
|------------|------------|--------|------------|-----------|---------------|-------------|
| | 1 ~220V | 50 | 154 | 0.62 | 2700 | 70 |

Performance parameters at key point:

| | psf | I | P1 | n | Q | Note |
|---|------|------|-----|---------|--------|----------|
| | (pa) | (A) | (W) | (r/min) | (m³/h) | |
| ① | 0 | 0.60 | 138 | 2721 | 2299 | |
| ② | 50 | 0.67 | 154 | 2658 | 1991 | |
| ③ | 92 | 0.73 | 168 | 2592 | 1597 | MAX EFF. |
| ④ | 117 | 0,76 | 176 | 2539 | 1183 | I MAX |

PS: Fan working performance tested with MAER wall plate, and under standard atmospheric pressure at 20°C

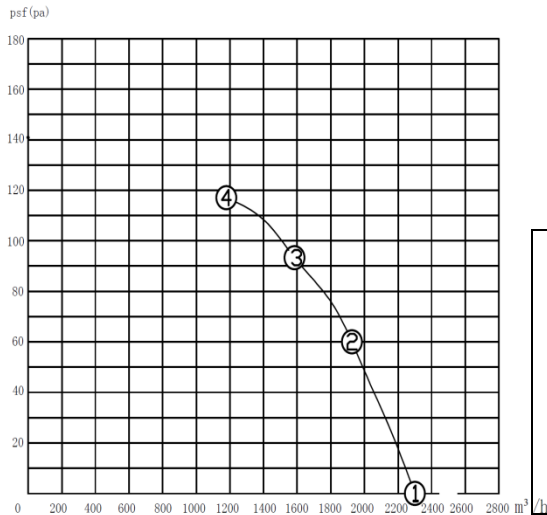

WIRING DIAGRAM

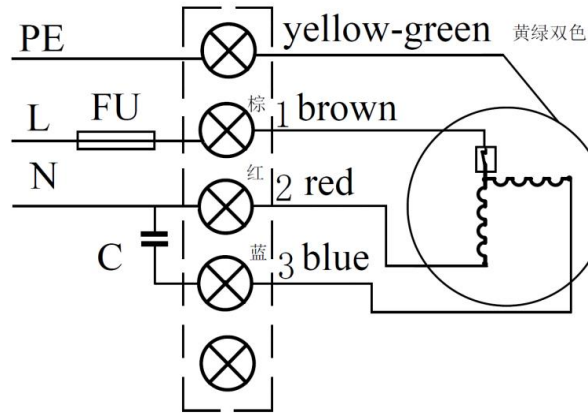

| | | |
|--|----------------|-------------------------------|
| | Product model | YDWF67L35P2-360N-300S |
| | Product type | External rotor axial flow fan |
| | Customer | 乌克兰 (Ukraine) |
| | Product number | MAER - 1704272 |
| | Certification | CE, CCC |

Condition of use:

- 1) Voltage and frequency: 1 ~ 220V + 5% (50 Hz)
- 2) Qualification requirements: Terminal block, the recommended standard of lead wire is not less than 0,5mm².
- 3) Installation position: vertical or upward.
- 4) Ambient temperature: -40 ~ 70°C.

THE EXTERNAL WIRING DIAGRAM:

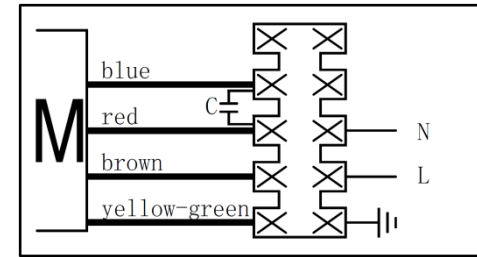

MARK

MAER AXIAL FAN MOTOR
MOTORS & FANS

MODEL: **YDWF67L35P2-360N-300 SUCTION**
2E-300-S

VOLTAGE: 220V / 50Hz

N.W/G.W. 3.3/3.9 kg

MEAS: 35x35x16 cm

CL. F WITH TERMINAL BOX

20180509X

Nameplate:

YDWF68L35P2-360N-300 S 1~220V50Hz 4μF / 450V

168W 0.73A 2592r/min @ 92Pa

CL. F IP44 2018/06

Tel:+380678807231, +380500679006

web:www.iceteco.com

e-mail: iceteko@gmail.com

| | | | |
|----------|--|---------------------|-----------------------------------|
| | The signature | (date)(month)(year) | ZHEJIANG MAER FAN MOTOR CO., LTD. |
| state | Deliver before After the confirmat ion | | |
| drawing | | | |
| audit | | | |
| approval | | | |