

A4

HYDRAULICS, HOISTING DEVICE

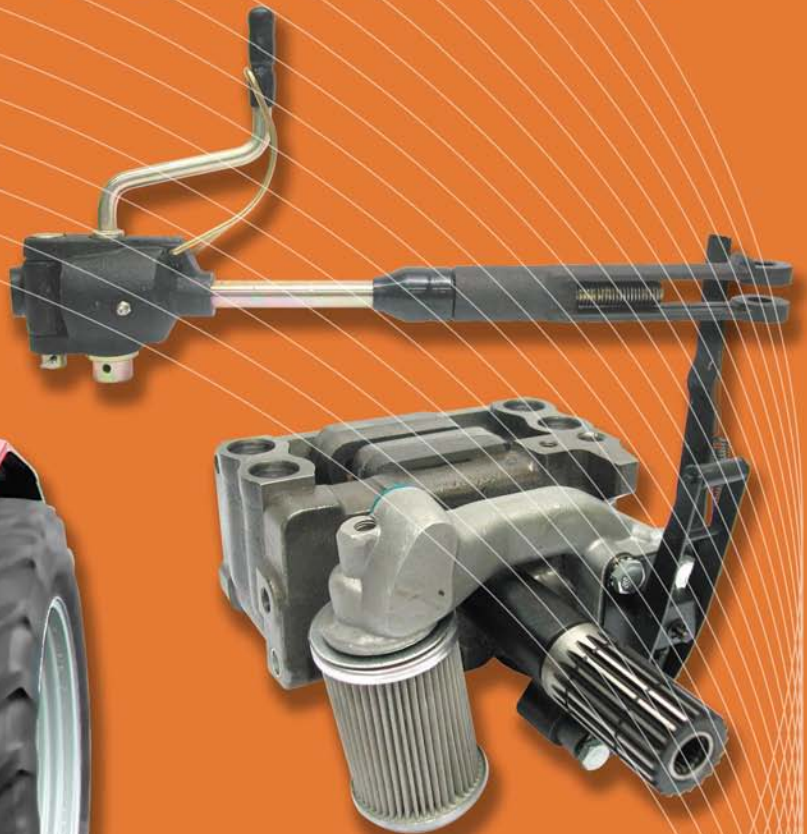

Note:

When ordering, please mention tractor model, type, serial number and pump number.

Available also other models with longer delivery time.



MF0078

TRACTOR MODEL	DESCRIPTION	ORDER NUMBER
MF 135, 148, 152, 152F, 152S, 152V, 158, 168, 185, 188, 240, 250, 253, 260, 263, 265, 275, 285, 290, 298, 340, 550, 560, 565, 575, 590, 675, 690, 698, 699, 1004, 1200, 1250	high flow pump	MF0078 1686765M91

Hydraulic pump - earlier model
MF0618

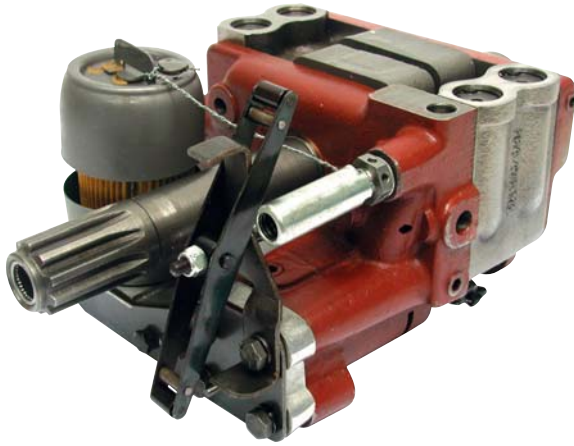

Hydraulic pump - later model
MF0619



HYDRAULIC PUMP REPAIR KIT

Note:

Check the differences of MK I, MK II and MK III pumps from page A4.03



MF0335

PART	FE 35 MF 35 MF 65 MF 765	MF 135 MF 165 MF 175 MF 178	MF 148 MF 168 MF 185 MF 188	MF 240 MF 265 MF 275	MF 565 MF 575 MF 590 MF 595	MF 675 MF 690 MF 698 MF 699 MF 1080 MF 698T	MF 365 MF 375 MF 390 MF 398 MF 399
Hydraulic pump	MF0618 184472M93		MF0619 (a, d) 1683301M93	MF0619 (d) 1683301M93	MF0619 (d) 1683301M93	MF0619 (d) 1683301M93	
Hydraulic pump repair kit	MF0039 1810858M91	MF0040 (b) 1810859M91	MF0335 (c) 1810860M91	MF0335 1810860M91	MF0335 1810860M91	MF0335 1810860M91	MF0335 1810860M91

- a - suction filter must be changed from under-side through housing hole center
- b - used in MK II pumps
- c - used in MK III pumps
- d - includes hydraulic control valve

26.10.2007

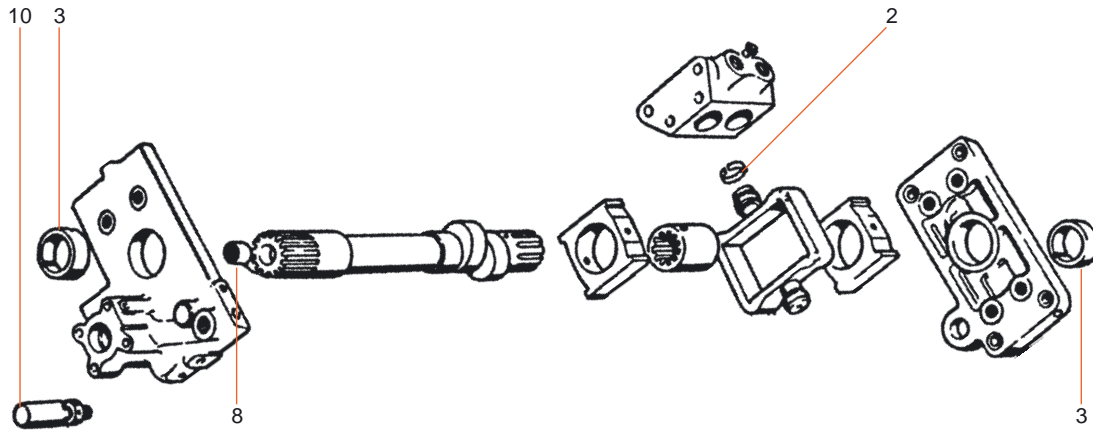

TRACTOR MODEL	2. PISTON RING	3. SHAFT BUSH	8. NEEDLE BEARING	10. RELIEF VALVE
FE 35, MF 35, MF 65, 765	V4012MR 82604M1	MF0229 1865012M1	V4641 1000251M1	V4635 (g) 828927M91
MF 135	V4040MR 897493M1	MF0229 1865012M1	V4641 1000251M1	V4635 (g) 828927M91 V4634 (h) 883402M92
MF 148	V4040MR 897493M1	MF0229 1865012M1	V4641 1000251M1	
MF 165, 168, 175 MF 178, 185, 188	V4040MR 897493M1	MF0229 1865012M1	V4641 1000251M1	V4635 (g) 828927M91 V4634 (h) 883402M92
MF 240	V4040MR 897493M1	MF0229 1865012M1	V4641 1000251M1	V4635 (g) 828927M91
MF 265, 275	V4040MR 897493M1	MF0229 1865012M1	V4641 1000251M1	
MF 565, 575, 590	V4040MR 897493M1	MF0229 1865012M1	V4641 1000251M1	
MF 595, 1080	V4040MR 897493M1	MF0229 1865012M1	V4641 1000251M1	
MF 675, 690, 698, 699	V4040MR 897493M1	MF0229 1865012M1	V4641 1000251M1	
MF 365, 375, 390, 398, 399	V4040MR 897493M1		V4641 1000251M1	

a - valve cap hole for MK I type pump 22,8 mm (picture below)
b - valve cap hole for MK II and MK III type pumps 22,0 mm (picture below)

g - **V4635** opening pressure 162-196 Bar
h - **V4634** opening pressure 175-210 Bar

DIFFERENCES BETWEEN MK1, MK2 AND MK3 TYPE PUMPS



PUMP TYPE	REPAIR KIT ORDER NUMBER	DIAMETER mm
MK I	MF0039	22,8
MK I	MF0040	22,8
MK II and III	MF0335	22,0

04.02.2008



VPJ4507



VPK1514

DFP762647

VPK1515



MF0813

TRACTOR MODEL	STEERING PUMP FILTER	HYDRAULIC SUCTION FILTER	HYDRAULIC FILTER	HYDRAULIC PUMP
MF 699		MF0506 (a) 1674984M2		
MF 350, 355, 360	TF5151 1886135M1	VPK1520 (a) 1870199M91		
MF 362, 365, 375, 390	TF5176 1662566M1	VPK1520 (a) 1870199M91		
MF 350, 355 360, 362 (d)		VPK1516 (b) 25015M91	DFP762647 3595175M1	
MF 365, 390, 398 (B18009→) 375 (d)		VPK1516 (b) 25015M91	DFP762647 3595175M1	VPK0109 3597706M91
MF 399 (d)		VPK1516 (b) 25015M91	DFP762647 3595175M1	
MF 3050, 3060, 3065, 3070,3080, 3085, 3090, 3095, 3115, 3125, 3140	VPJ4507 (f) 3615949M1		VPK1514 (e) 3581032M2 VPK1515 (f) 3616579M1	MF0813 3382280M1
MF3610, 3630, 3645, 3650, 3655, 3670, 3680, 3690			VPK1513 3386701M1	
MF 3635, 3645, 3655, 3690			VPK1514 3619712M1	
MF 6110, 6120, 6130, 6140, 6150, 6160, 6170, 6180, 6190 (→M049008): 6235, 6245, 6255, 6260, 6265, 6270, 6280, 6290				MF0813 3382280M1

- a - inside center housing
- b - to inlet hose
- d - hydraulic pump on engine timing gear
- e - up to serial no S095020
- f - from serial no S095021

26.10.2007



VPK4018

TF5171

MF0503

MF0812

TRACTOR MODEL	STACK PIPE	HYDRAULIC PUMP ^(d) SUCTION FILTER	OIL COOLER FILTER	HYDRAULIC FILTER
FE 35, MF 35, 65, 765		VPK1520 (e) 1687042M91		
MF 135, 148	MF0180 883788M91	VPK1520 (e) 1687042M91 V406 1810291M91	MF0503 191855M4	
MF 165, 168 MF175, 178 MF 185, 188	MF0180 883788M91 VPK4018 898229M1 VPK4019 3808400M1	VPK1520 (e) 1687042M91 TF5171 1674984M91	MF0503 191855M4 V406 1810291M91 TF5171 1674984M91	
MF 240	VPK4019 3808400M1	VPK1520 (e) 1687042M91 TF5171 1674984M91	MF0506 1810694M92	
MF 265, 275	VPK4019 3808400M1	VPK1520 (e) 1687042M91 TF5171 1674984M91	TF5171 1674984M91 MF0506 (c) 1810694M92	
MF 565, 575 MF 590, 595	VPK4019 3808400M1 VPK4018 (f) 898229M1	VPK1520 (e) 1687042M91 TF5171 1674984M91	TF5171 1674984M91 MF0506 (c) 1810694M92	
MF 675, 690, 698, 699 698T	VPK4019 3808400M1	VPK1520 (e) 1687042M91 TF5171 1674984M91	MF0506 1810694M92	
MF 1080	VPK4018 898229M1		TF5171 1674984M91 MF0506 (c) 1810694M92	
MF 355, 365, 375, 390, 398, 399	VPK4018 898229M1 VPK4019 3808400M1			DFP762647 3595175M1

c - MF0506 micro filter

d - check dimensions from table beside

e - in earlier models the fastening screw must be shortened 9.5 mm, install the including seal to top-side

f - only 595

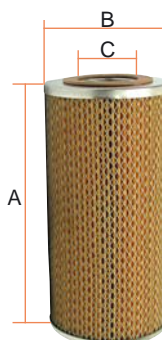

ORDER NUMBER	A mm	B mm	C mm
VPK1520	88+7	62	42
MF0503	113	45	24
V406	84	44	16
TF5171	150	72	35/0

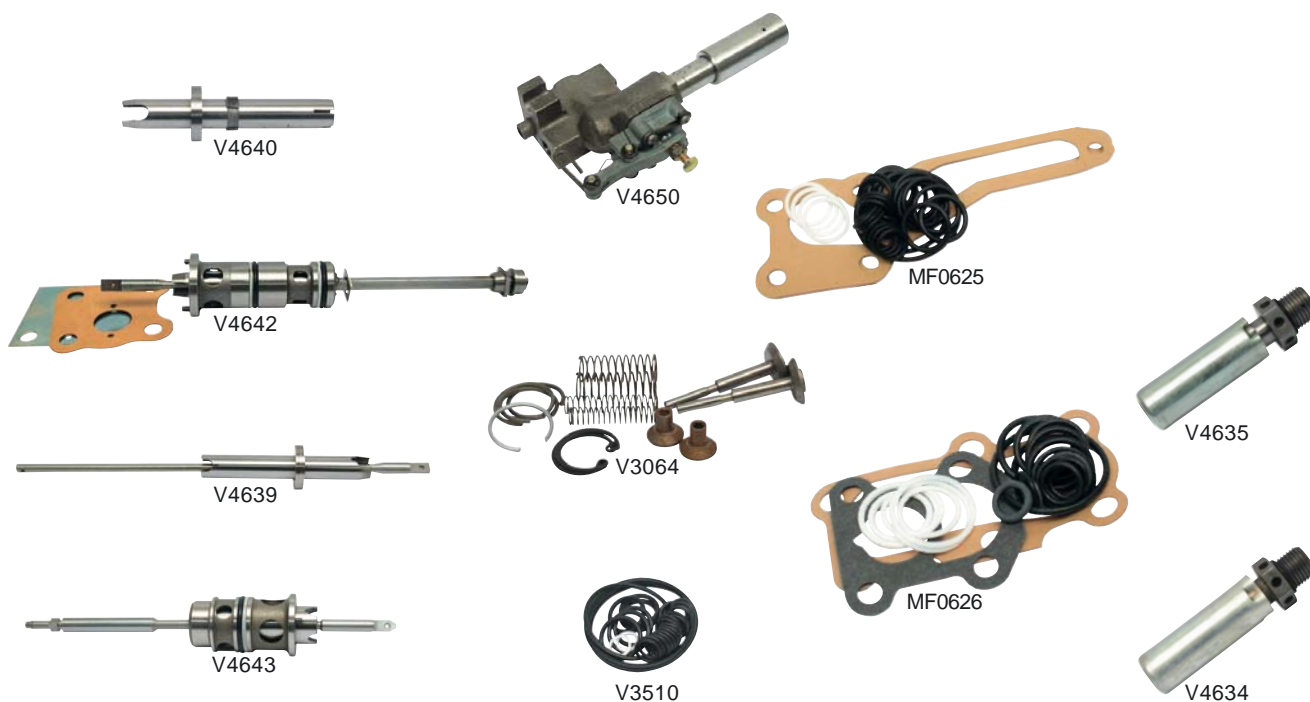

TRACTOR MODEL	CONTROL VALVE	HYDRAULIC CONTROL VALVE	VALVE CHAMBER REPAIR KIT (d)	GASKET SETS 1. INCLUDES ONLY O-RINGS 2. INCLUDES PUMP GASKETS	RELIEF VALVE	
FE 35, MF 35, 65, 765	V4640 189427M92		V3064 1810678M91	V3510 894906M91	MF0625 1810684M92	V4635 828927M92
MF 135, 148	V4639 (a) 897507M94 V4642 (b) 1862486M96 V4643 (c) 1681789M91	V4650 (c) 1680061M91	V3064 1810678M91	V3510 894906M91	MF0625 (a) 1810684M92 MF0626 (c) 1810680M93	V4635 (e) 828927M92 V4634 (f) 883402M92
MF 165, 168 MF 175, 178 MF 185, 188	V4639 (a) 897507M94 V4642 (b) 1862486M96 V4643 (c) 1681789M91	V4650 (c) 1680061M91	V3064 1810678M91	V3510 894906M91	MF0625 (a) 1810684M92 MF0626 (c) 1810680M93	V4635 (e) 828927M92 V4634 (f) 883402M92
MF 240	V4643 1681789M91	V4650 1680061M91	V3064 1810678M91	V3510 894906M91	MF0626 1810680M93	V4635 (e) 828927M92
MF 265, 275	V4643 1681789M91	V4650 1680061M91	V3064 1810678M91	V3510 894906M91	MF0626 1810680M93	
MF 565, 575, 590	V4643 1681789M91	V4650 1680061M91	V3064 1810678M91	V3510 894906M91	MF0626 1810680M93	
MF 595, 1080			V3064 1810678M91	V3510 894906M91	MF0626 1810680M93	
MF 675, 690, 698, 698T, 699	V4643 1681789M91	V4650 1680061M91	V3064 1810678M91	V3510 894906M91	MF0626 1810680M93	
MF 365, 375, 390, 390T, 398, 399	V4643 (g) 1681789M91			V3510 894906M91		

- a - for pump where filter must be changed from top-side
- b - improved model, see picture
- c - for pump where filter must be changed from under-side
- d - set **V3064** for one chamber
- e - **V4635** opening pressure 162-196 Bar
- f - **V4634** opening pressure 175-210 Bar
- g - →8/91

CONTROL VALVE ROLLS AND PIN

MF0801

- MF 20, 50, 135, 148, 165, 168, 175, 178, 185, 188, 230, 240, 250, 265, 275, 285, 290, 298, 350, 355, 360, 375, 390, 390T, 398, 399, 565, 575, 590, 595, 675, 690, 698, 698T, 699, 1200, 1250



26.10.2007

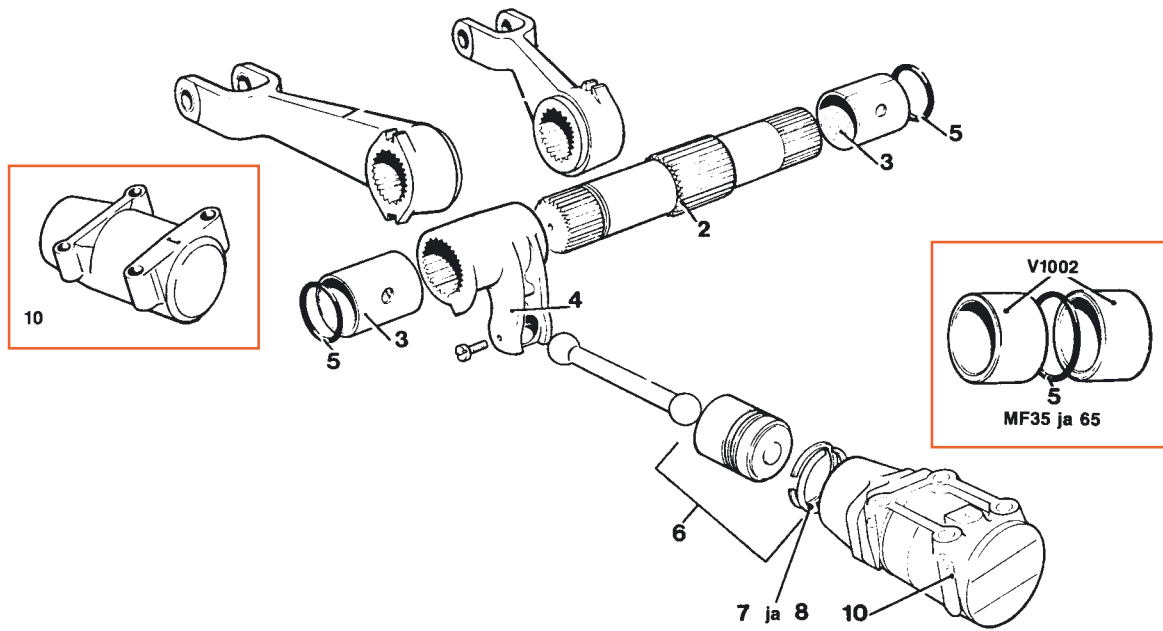

PART	FE 35 MF 35	MF 65 MF 765	MF 135 MF 148 MF 165 MF 240	MF 168 MF 175 MF 178 MF 185 MF 188	MF 365 MF 375 MF 390	MF 398 MF 399	MF 265 MF 275 MF 565 MF 575 MF 590	MF 595 MF 1080	MF 675 MF 690 MF 698 MF 699 MF698T
2. Shaft	V7008/35 184359M2	V7008/35 184359M2	V7258 897567M3	V7258 897567M3	V7258 897567M3	V7258 897567M3	V7258 897567M3		V7258 897567M3
3. Bush	V1002 181018M1	V1002 181018M1	V1013 886089M1	V1013 886089M1	V1013 886089M1	V1013 886089M1	V1013 886089M1	V1013 886089M1	V1013 886089M1
4. Center arm			V7257 897568M1						
5. O-ring	V3596 195565M1	V3596 195565M1	V3566 359184X1	V3566 359184X1	V3566 359184X1	V3566 359184X1	V3566 359184X1	V3566 359184X1	V3566 359184X1
6. Piston with rings	V1006 (b) 184443M91	V1006 184443M91		V1010 (d) 1665738M91			V1010 1665738M91		V1010 1665738M91
7. Piston ring set teflon gaskets			MF0633 3761478M1	MF0634 (d) 3761477M1			MF0634 3761477M1		MF0634 3761477M1
8. Piston ring set (earlier model) cast iron	V1063 (a) 180898M1 V1063/35 (b) 184447M1	V1063/35 184447M1	V1064 (c) 897564M1	V1065 897597M1			V1065 897597M1		V1065 897597M1
10. Slave cylinder			MF0037 897560M3	MF0038 (d) 1671082M1			MF0038 1671082M1		MF0038 1671082M1

- a - Ø 63,5 mm
- b - Ø 76 mm
- c - Ø 79 mm
- d - Ø 85 mm

MF LIGHT DUTY LEVELLING BOXES THREAD Ø 19 mm

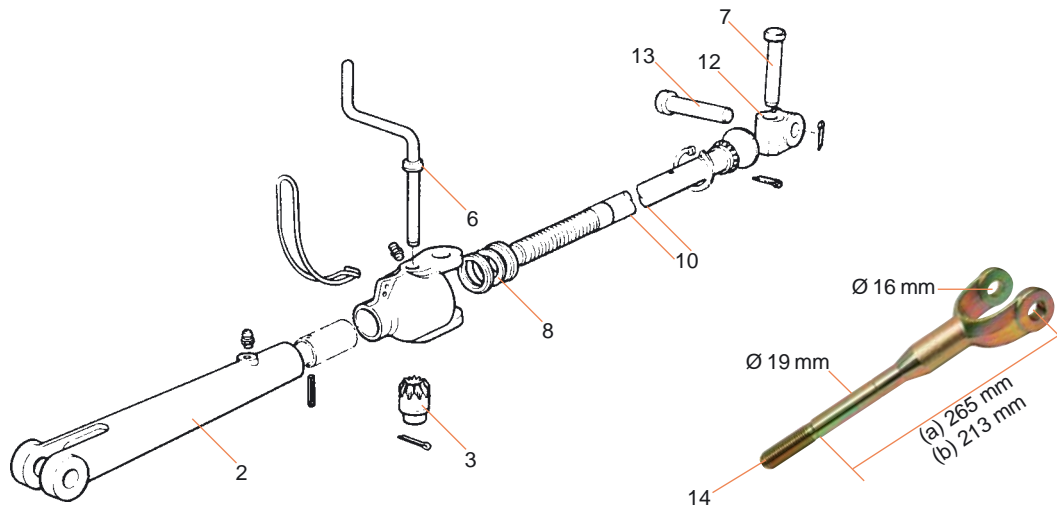

PART	MF 35 MF 135	MF 65 MF 765 short model	MF 65 MF 765 long model	MF 135 short model	MF 135 long model	MF 148	MF 240
1. Complete box assy	V4003 182642M92	V4005 888628M91	V4004 184347M93	V4005 (c) 888628M91	MF0648 (c) 897678M93		MF0648 (c) 897678M93
2. Levelling and lift rod fork		V4038 897659M1		V4038 897659M1	V4038 (c) 897659M1	V4038 (c) 897659M1	V4038 (c) 897659M1
3. Gear	V1905 181345M2	V1905 181345M2	V1905 181345M2	V1905 181345M2	V1905 181345M2	V1905 181345M2	V1905 181345M2
6. Handle	V4032 1662382M1	V4032 1662382M1	V4032 1662382M1	V4032 1662382M1	V4032 1662382M1	V4032 1662382M1	V4032 1662382M1
7. Lower clevis pin	V1036 180860M1	V1036 180860M1	V1036 180860M1	V1036 180860M1	V1036 180860M1	V1036 180860M1	V1036 180860M1
8. Bearing	V3999 195457M1	V3999 195457M1	V3999 195457M1	V3999 195457M1	V3999 195457M1	V3999 195457M1	V3999 195457M1
10. Levelling shaft	V4297/35 185220M1	V4297/35 185220M1	V4297/65 1660375M1	V4297/35 185220M1	V4297/65 1660375M1	V4297 907980M1	V4297/65 1660375M1
12. Knuckle	V1015 1884376M1	V1015 1884376M1	V1015 1884376M1	V1015 1884376M1	V1015 1884376M1	V1015 1884376M1	V1015 1884376M1
13. Upper clevis pin	V1036 180860M1	V1036 180860M1	V1036 180860M1	V1036 180860M1	V1036 180860M1	V1036 180860M1	V1036 180860M1
14. Fork LH	V8522 (b) 826410M92	V8524 (a) 184350M91	V8524 (a) 184350M91	V8522 (b) 826410M92	V8524 (a) 184350M91	V8524 (a) 184350M91	V8524 (a) 184350M91

a - long, working length 265 mm
b - short, working length 213 mm
c - HD levelling and lift rod fork

LEVELLING SHAFT OVERALL LENGHT

ORDER NUMBER	LENGTH mm
V4297	365 mm
V4297/35	260 mm
V4297/65	310 mm

FERGUSON 20 LEVELLING BOXES

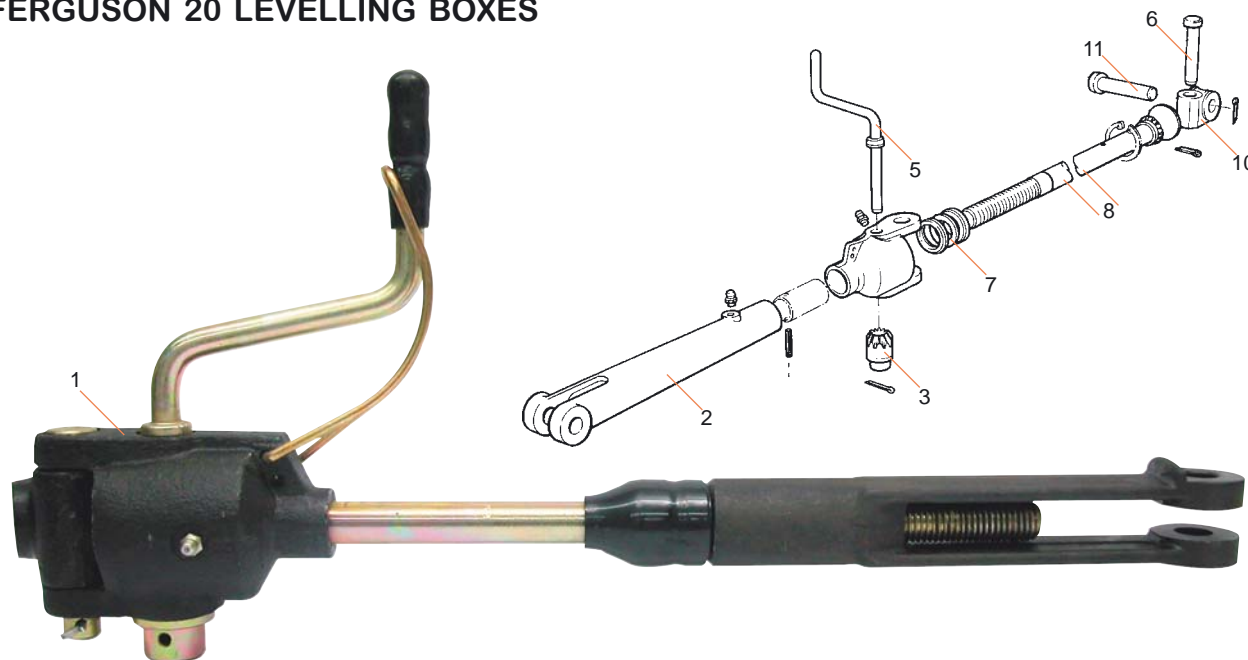

DESCRIPTION	ORDER NUMBER
1. Complete box assy	V4002 180854M91
2. Levelling and lift rod fork	V4008 890674M1
3. Gear	V1905 181345M2
5. Handle	V4032 1662382M1
6. Lower clevis pin	V1036 180860M1

DESCRIPTION	ORDER NUMBER
7. Bearing	V3999 195457M1
8. Levelling shaft	V4297 907980M1
10. Knuckle	V1015 1884376M1
11. Upper clevis pin	V1036 180860M1

FERGUSON 20 LOWER LINKS



LOWER LINK ARM 22 mm	LOWER LINK WELD ON END	MOUNTING PIN
MF0103 882698M92	V8510/1 826769M1 CAT 1 22 mm	V1025/35 181229M5
	V8510/2 184461M92 CAT 2 28 mm	

26.10.2007

MF HD LEVELLING BOXES THREAD Ø 25,4 mm

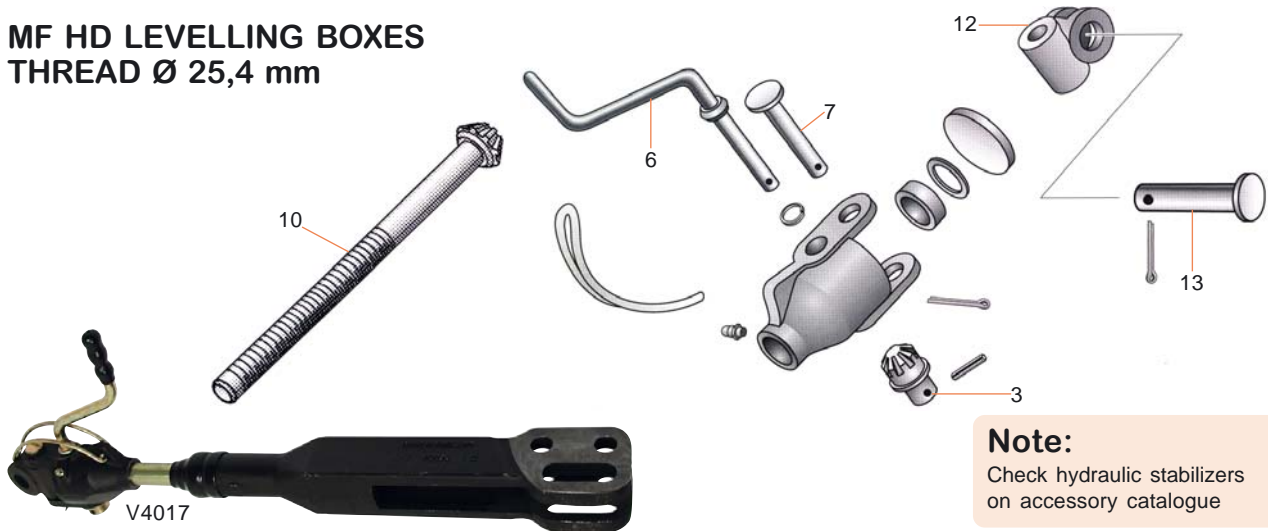

Note:

Check hydraulic stabilizers on accessory catalogue

PART	MF 65 MF 165 MF 765 short model	MF 65, 165 175, 178 265, 275, 765 long model	MF 168 175, 178 185 strong model	MF 275 MF 575 MF 675	MF 590 MF 690 MF 698 MF 699	MF 595 MF 1080
1. Complete box assy	V4015 893569M91	V4016 893570M91	V4017 1863053M94	V4017 1863053M94	V4017 1863053M94	
2. Fork	V4028 893405M3	V4028 893405M3	V4022 1861392M3	V4022 1861392M3	V4022 1861392M3	
3. Gear	V1905 181345M2	V1905 181345M2	V1905 181345M2	V1905 181345M2	V1905 181345M2	V1905 181345M2
6. Handle	V4032 1662382	V4032 1662382	V4032 1662382	V4032 1662382	V4032 1662382	
7. Lower clevis pin	V4026 893567M1	V4026 893567M1	V4026 893567M1	V4026 893567M1	V4026 893567M1	V4026 893567M1
10. Levelling shaft		V4294 897651M1		V4294 897651M1		
12. Knuckle	V1017 893560M1	V1017 893560M1	V1017 893560M1	V1017 893560M1	V1017 893560M1	V1017 893560M1
13. Upper clevis pin	V4029 1694025M1	V4029 1694025M1	V4029 1694025M1	V4029 1694025M1	V4029 1694025M1	V4029 1694025M1
14. Fork	MF0651 1863057M91	V4292 893562M91	MF0652 1863888M91	MF0651 1863057M91	MF0652 1863888M91	

**FORK
OVERALL LENGTH**
(number 14)



**LEVELLING SHAFT
OVERALL LENGTH**
(number 10)

ORDER NUMBER	OVERALL LENGTH
V4292	410 mm
MF0652	375 mm
MF0651	315 mm

ORDER NUMBER	OVERALL LENGTH
V4294	380 mm
V4295	320 mm
V4298	290 mm

12.01.2009

Note:

Check hydraulic stabilizers on accessory catalogue

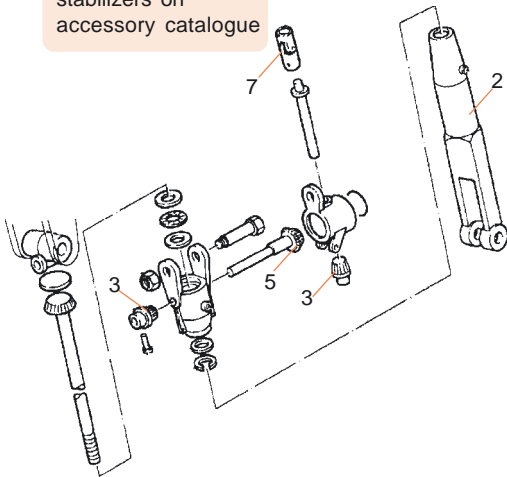

MF0800



MF0850



MF0895



MF0898

PART	MF 368 MF 375	MF 375, 390, 398	MF 375, 390, 399	MF 600	MF 3000	MF 3060, 3065, 3070, 3080, 3090
	580-690 mm	600-740 mm	600-740 mm	640-780 mm	760-860 mm	760-860 mm
1. Complete box assy	MF0895 1696733M93				MF0898 3582494M91	MF0850 (a) 3382727M93
2. Fork		V4022 1861392M3				MF0853 3384035M3
3. Gear	V1905 181345M2		V1905 181345M2	V1905 181345M2	V1905 181345M2	V1905 181345M2
5. Shaft	MF0891 1682308M1		MF0891 1682308M1	MF0891 1682308M1	MF0891 1682308M1	MF0891 1682308M1
7. Universal joint	MF0894 3580976M1		MF0894 3580976M1	MF0894 3580976M1	MF0894 3580976M1	MF0894 3580976M1
12. Fork						MF0852 3382728M1 V4292 893562M91

a - →P279011



LEVELLING YOKE

MF1102
3580550M91

- MF3050, 3060, 3065, 3070, 3080, 3090

ORDER NUMBER

OVERALL LENGTH

Fork	MF0852	540 mm
Fork	V4292	410 mm

26.10.2007

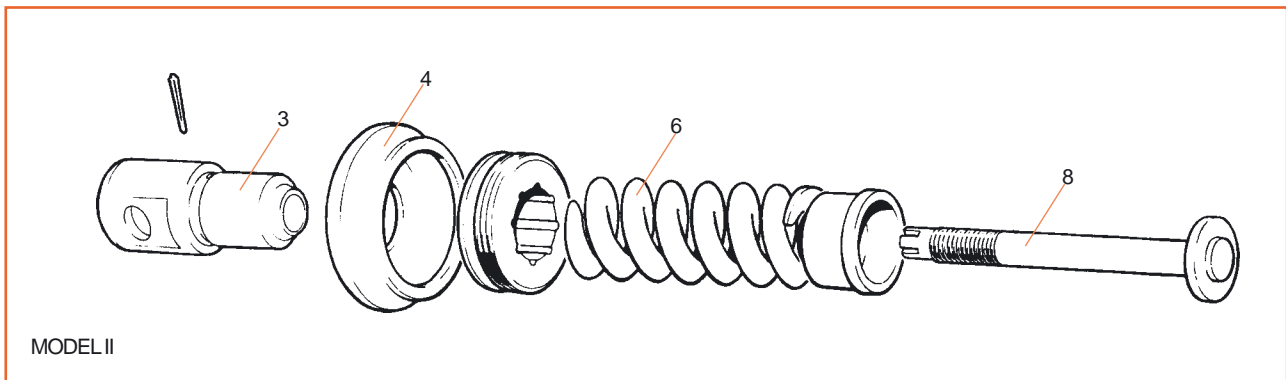
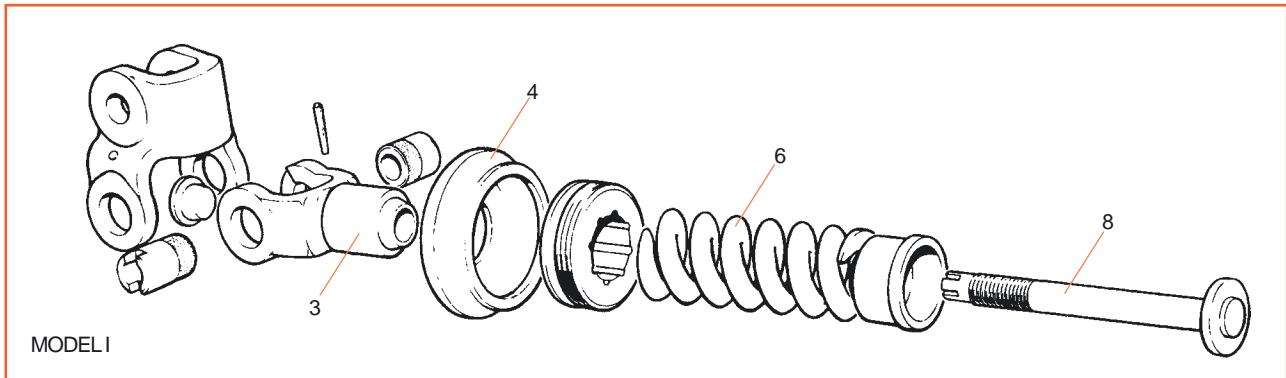

TRACTOR MODEL		3. ROCKER LINK	4. RUBBER BOOT	6. SPRING	8. BOLT
FE 35, MF 35, 65, 765		V1103 180972M2	V1096 887654M2	V1102 182582M1	
MF 135	model I	V1103 180972M2	V1096 887654M2	V1102 182582M1	V1107 898136M1
	model II	MF0640 1863389M1	V1096 887654M2	V1102 182582M1	MF0644 886348M2
MF 148		MF0640 1863389M1	V1096 887654M2	V1102 182582M1	MF0644 886348M2
MF 165, 168, MF 175, 178, MF 185, 188	model I	V1103 180972M2	V1096 887654M2	V1102 182582M1	V1107 898136M1
	model II	MF0640 1863389M1	V1096 887654M2	V1102 182582M1	MF0644 886348M2
MF 240		MF0640 1863389M1	V1096 887654M2	V1102 182582M1	MF0644 886348M2
MF 265, 275		MF0640 1863389M1	V1096 887654M2	V1102 182582M1	MF0644 886348M2
MF 565, 575, 590		MF0640 1863389M1	V1096 887654M2	V1102 182582M1	MF0644 886348M2
MF 1080, 595			V1096 887654M2		
MF 675, 690		MF0640 1863389M1	V1096 887654M2	V1102 182582M1	MF0644 886348M2
MF 698, 699, 698T		MF0640 1863389M1	V1096 887654M2		MF0644 886348M2

12.01.2009

LINK ARMS

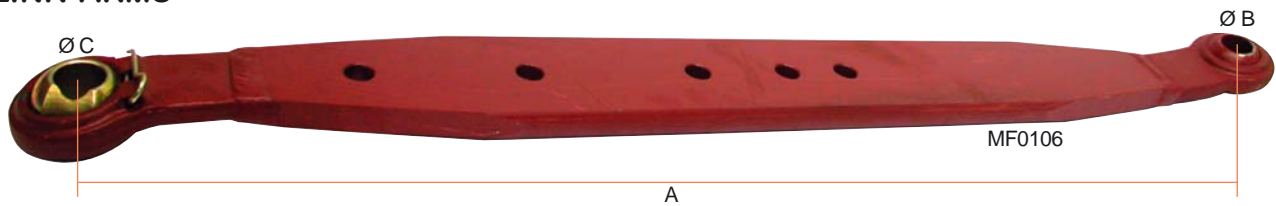

TRACTOR MODEL	DIMENSIONS			ORDER NUMBER	
	A mm	B mm	C mm	RIGHT	LEFT
FE 35, MF 35, 135	812	22	22	MF0103 882754M91	MF0103 882754M91
FE 35, MF 35, 135, 148, 240	812	22	28	MF0104 1884725M91	MF0104 1884725M91
MF 65, 765, 165, 168, 175, 178	864	28	28	MF0105 1884763M91	MF0105 1884763M91
MF 65, 765, 165, 168, 175, 178, 265, 565	965	28	28	MF0653 886451M94	MF0653 886451M94
MF 185, 188, 265, 275, 575 HD	965	28	28	MF0106 1863435M94	MF0106 1863435M94

TELESCOPIC STABILIZER PAIR



TRACTOR MODEL	ORDER NUMBER
MF 35, 130, 133, 135, 148, 240	T0177, T0177N (b)
MF 65, 165, 175, 178 dry brakes	T0178
MF 100, 130, 133, 135, 148, 150, 152, 154, 155, 158, 164, 165, 168, 174, 174-4S, 175, 178, 180, 184, 184-4S, 185, 187, 188, 194, 200, 203, 205, 230, 240, 250, 253, 254, 255, 260, 261, 263, 264T, 265, 270, 274, 275, 283, 284S-4S, 285, 290, 294, 298, 500, 550, 560, 565, 575, 585, 590, 592, 595, 595MKII wet brakes	T0412
MF 600, 670, 675, 690, 695, 698, 698T, 699	T0414
MF 590	T0413

STABILIZER SUPPORTS



REPAIR KIT FOR LOWER LINK QUICK COUPLING END



T0623 3904032M91
- CAT2, Ø 56 mm

TRACTOR MODEL	LEFT	RIGHT
MF 65, 100, 130, 165, 175, 178 dry brakes (c)	T0416	T0417
MF 100, 130, 133, 135, 148, 150, 152, 154, 155, 158, 164, 165, 168, 174, 174-4S, 175, 178, 180, 184, 184-4S, 185, 187, 188, 194, 200, 203, 205, 230, 235, 240, 245, 250, 253, 254, 255, 260, 261, 263, 264T, 265, 270, 274, 275, 283, 284S-4S, 285, 290, 294, 298, 500, 550, 560, 565, 575, 585, 590, 592, 595, 595 MKII, 598, 600, 670, 675, 690, 695, 698, 598T, 699 wet brakes (d)	T0418	T0419

b - **T0177N** long model, check the differences from the accessory catalogue

c - dry brakes (round pipe)

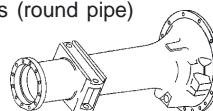

d - wet brakes (angular pipe)

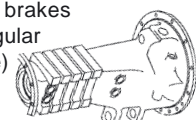

26.10.2007



MF0657

PART	FE 35 MF 35 MF 135	MF 65 MF 765	MF 165 MF 175 MF 178	MF 165, 168, 185, 188, 265 275, 565, 575, 675
			DRY BRAKES	WET BRAKES
Mounting pin	V1025/35 181229M5	MF0657 184356M1	MF0657 184356M1	MF0658 1867243M1

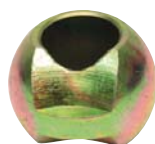

MF8526



MF0107



V8510

SIZE (CAT)	REPLACEMENT BALL	RETAINING CLIP	RETAINING CLIP	LOWER LINK WELD ON END
CAT 1 22 mm	V8525 886428M1	MF0107 1869219M1	MF0107 1869219M1	V8510/1 826769M1
CAT 2 28 mm	V8526	MF0107 1869219M1	MF0107 1869219M1	V8510/2 184461M92

MF TOP LINK

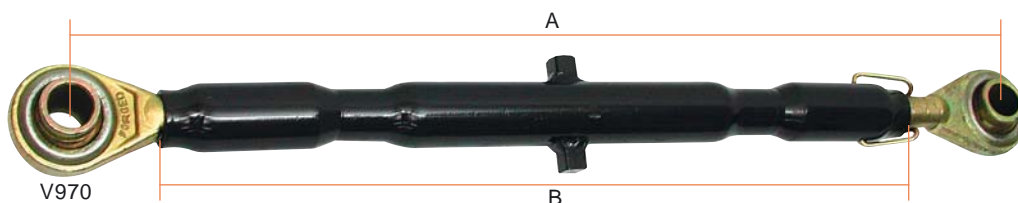

V970

MODEL	DIMENSION A		DIMENSION B mm	HEAD SIZES mm	ORDER NUMBER
	MIN mm	MAX mm			
MF small	584	724	438	19 CAT 1-1	V959 180855M91
MF large - small	584	724	438	25-19 CAT 2-1	V960 894376M91
MF large	670	832	546	25 CAT 2-2	V970 893439M91



HYDRAULIC ASSISTER RAM KIT

MF0142

- MF 65, 165, 175, 178 (dry brakes)
- needs fitting
- lift capacity raises 900 kg



HYDRAULIC ASSISTER RAM KIT

MF0142HD

- MF 165, 168, 185, 188 (wet brakes)
- MF 265, 275, 565, 575, 590
- lift capacity raises 1500 kg



Ø 22 mm

Ø 22 mm

AUXILIARY CYLINDER

MF0741

- piston diameter 35 mm
- assembling dimension 445 mm
- stroke 300 mm
- lift capacity 1500 kg



TRIPLE PORT ISOLATOR

V3051

- FE 35, MF 35, 65, 135, 165, 168, 175, 178, 185, 188
- thread $\frac{3}{8}$ "

26.10.2007

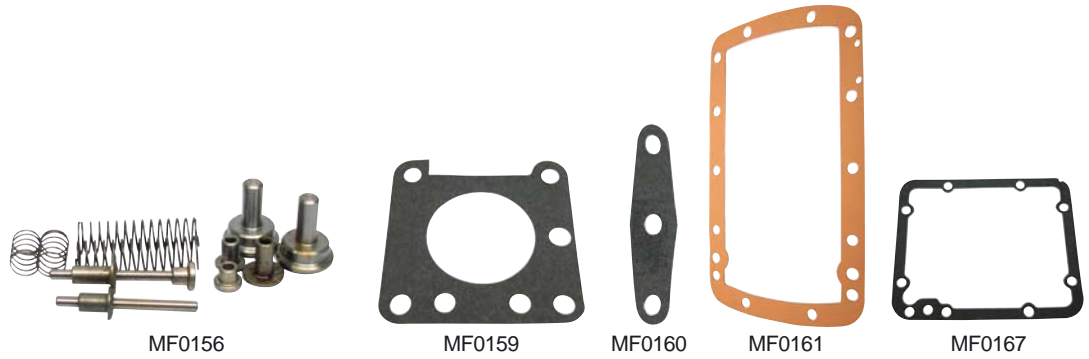

TRACTOR MODEL	ENGINE TYPE	CHAMBER REPAIR KIT	PUMP CHAMBER GASKET	CYLINDER GASKET	TOP COVER GASKET	PUMP/ HOUSING GASKET
Ferguson Gasoline 80 mm	TEA 20	MF0156 826222M1	MF0159 890664M1	MF0160 104275	MF0161 7042	MF0167 181065M1
Ferguson Gasoline, petroleum 85 mm	TEA, TED20	MF0156 826222M1	MF0159 890664M1	MF0160 104275	MF0161 7042	MF0167 181065M1
Ferguson Diesel	TEF 20 C	MF0156 826222M1	MF0159 890664M1	MF0160 104275	MF0161 7042	MF0167 181065M1



RELIEF VALVE

V046



HYDRAULIC CONTROL VALVE

MF0646



PISTON RING SET

V1063