

TECHNICAL DRAWING

GK 2500 S

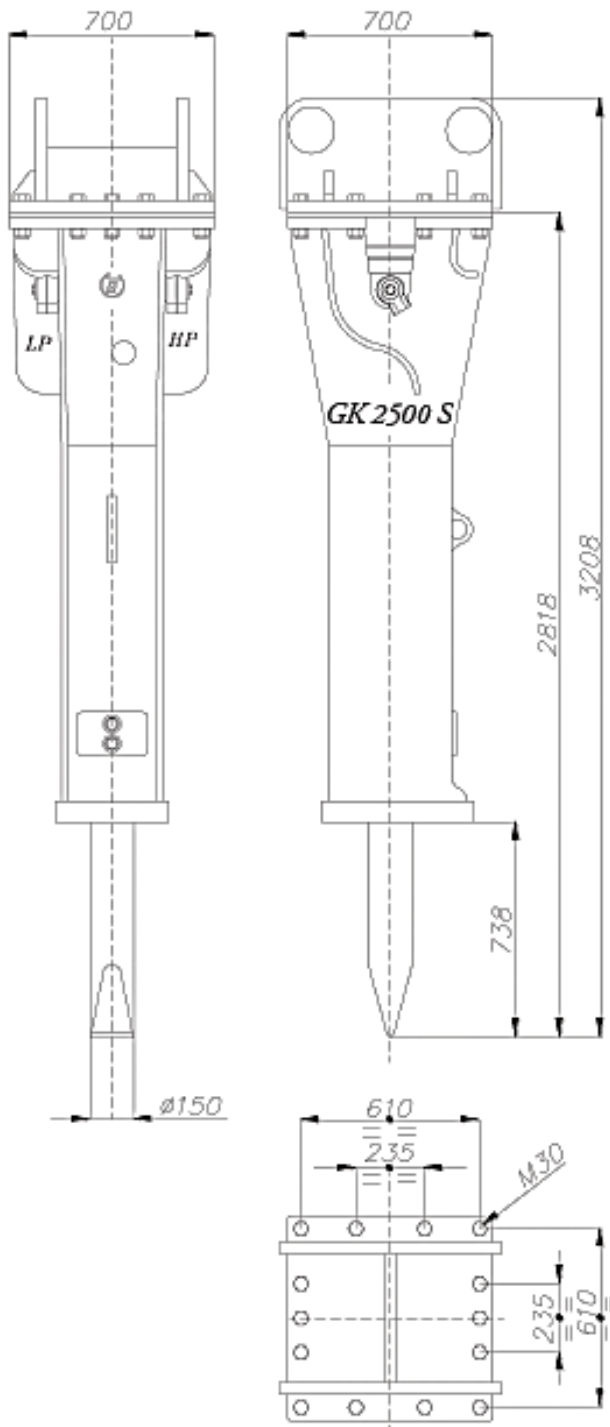

WEIGHT AND DIMENSIONS

Operating Weight	2400 kg
Height	3210 mm
Width	700 mm
Chisel Diameter	150 mm

FITTING TO CARRIER

Carrier weight	280 -400 Ton
Inner Ø HP line	32 mm
Inner Ø LP line	38 mm

At the breaker:

HP thread	1" ¼ GAS
LP thread	1" ¼ GAS

POWER DATA

Power of the breaker	61 HP
Required power	78 HP
Yield	0.78
Energy of the blow	5000 Joule
Blows per minute	550 – 700

SETTINGS

Oil Supply	220 -230 L/Min
Working pressure	140 -150 bar
Backpressure	12 bar
Relief valve (carrier)	200 bar
Max. oil temperature	80° C
Nitrogen Pressure	40 bar
Noise level	88 dB-A