

SPARE PARTS EXPLODED VIEW GAS WALL BOILERS

Model

EGIS - AS

R8215807-03EN - Edition 03 - 01/03/2008

3300252		EGIS 24 FF NG (IT)
3300179		EGIS 24 FF N
3300193		EGIS 24 FF NG (EAA1)
3300195		EGIS 24 FF NG (EAA2)
3300253		EGIS 24 FF LPG (IT)
3300180		EGIS 24 FF B
3300254		EGIS 24 CF NG (IT)
3300181		EGIS 24 CF N
3300194		EGIS 24 CF NG (EAA1)
3300196		EGIS 24 CF NG (EAA2)
3300255		EGIS 24 CF LPG (IT)
3300182		EGIS 24 CF B
3300183		AS 24 FF NG (IT, RO, PI)
3300184		AS 24 FF LPG (IT, RO, PI)
3300185		AS 24 CF NG (IT, RO, PI)
3300186		AS 24 CF LPG (IT, RO, PI)
Reference	Ind.	Model type	Begin	End

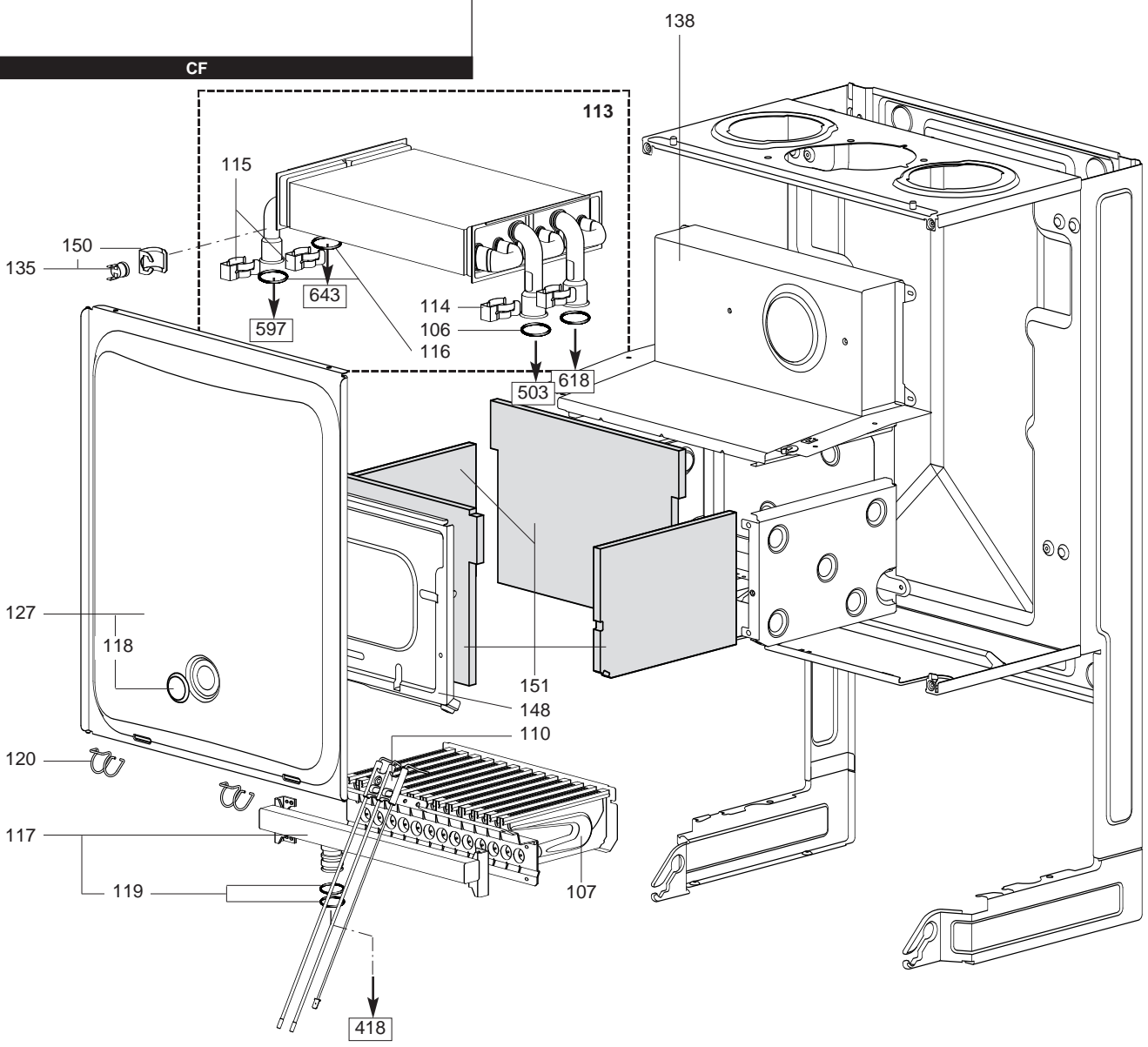
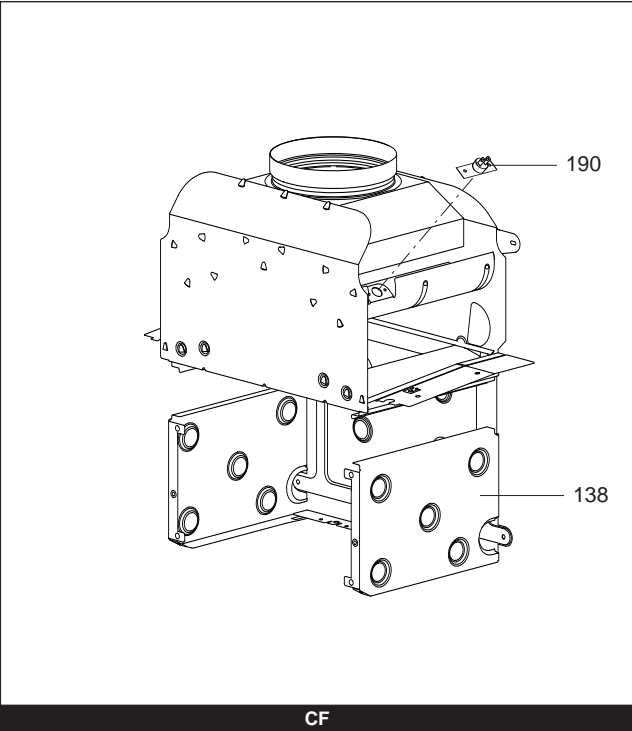

Key N	Description	Manf. Pt. N	Type	EGIS		AS		Manf. date	
				FF	CF	FF	CF	from	to
0100	SEALED CASE								
0106	O-RING 3,53X17,04	65104262		•	•	•	•		
0107	BURNER	65104220		•					01/08
	BURNER	65104220		•					02/08
	BURNER	65104220			•	•			
	BURNER	65106294		•		•			03/08
0110	ELECTRODE (IGNITION/DETECTION)	65104549		•	•	•	•		
0113	MAIN EXCHANGER	65105094		•		•			02/08
	MAIN EXCHANGER	65105094			•		•		
	MAIN EXCHANGER	65106300		•		•			03/08
0114	CLIP	61307589		•	•	•	•		
0115	CLIP	65105109		•	•	•	•		
0116	O - RING (13X2)	65105108		•	•	•	•		
0117	GAS MANIFOLD	65105118	LG	•		•			02/08
	GAS MANIFOLD	65105118	LG		•		•		
	GAS MANIFOLD	65106606	LG	•		•			03/08
	GAS MANIFOLD	65104302	NG	•		•			02/08
	GAS MANIFOLD	65104302	NG		•		•		
	GAS MANIFOLD	65106302	NG	•		•			03/08
0118	SIGHT GLASS	65104232		•		•			
0119	O-RING 17,17X1,78	65104303		•	•	•	•		
0120	SPRING FRONT PANEL (KIT)	65104298		•		•			
0127	PANEL (FRONT - SEALED CHAMBER)	65104236		•		•			05/07
	PANEL (FRONT - SEALED CHAMBER)	65105678		•		•			06/07
0135	THERMOSTAT	65104500		•	•	•	•		
0138	COMBUSTION CHAMBER	65104218			•		•		
0148	PANEL (COMBUSTION CHAMBER)	65104240		•		•			02/08
	PANEL (COMBUSTION CHAMBER)	65104240			•		•		
	PANEL (COMBUSTION CHAMBER)	65106296		•		•			03/08
0150	CLIP	61010050		•	•	•	•		
0151	PANELS (KIT)	65104695		•		•			02/08
	PANELS (KIT)	65104695			•		•		
	PANELS (KIT)	65106298		•		•			03/08
0190	THERMOSTAT 75-65°C	999539			•		•		

200
300
400

EGIS - AS

Domestic Gas Boilers

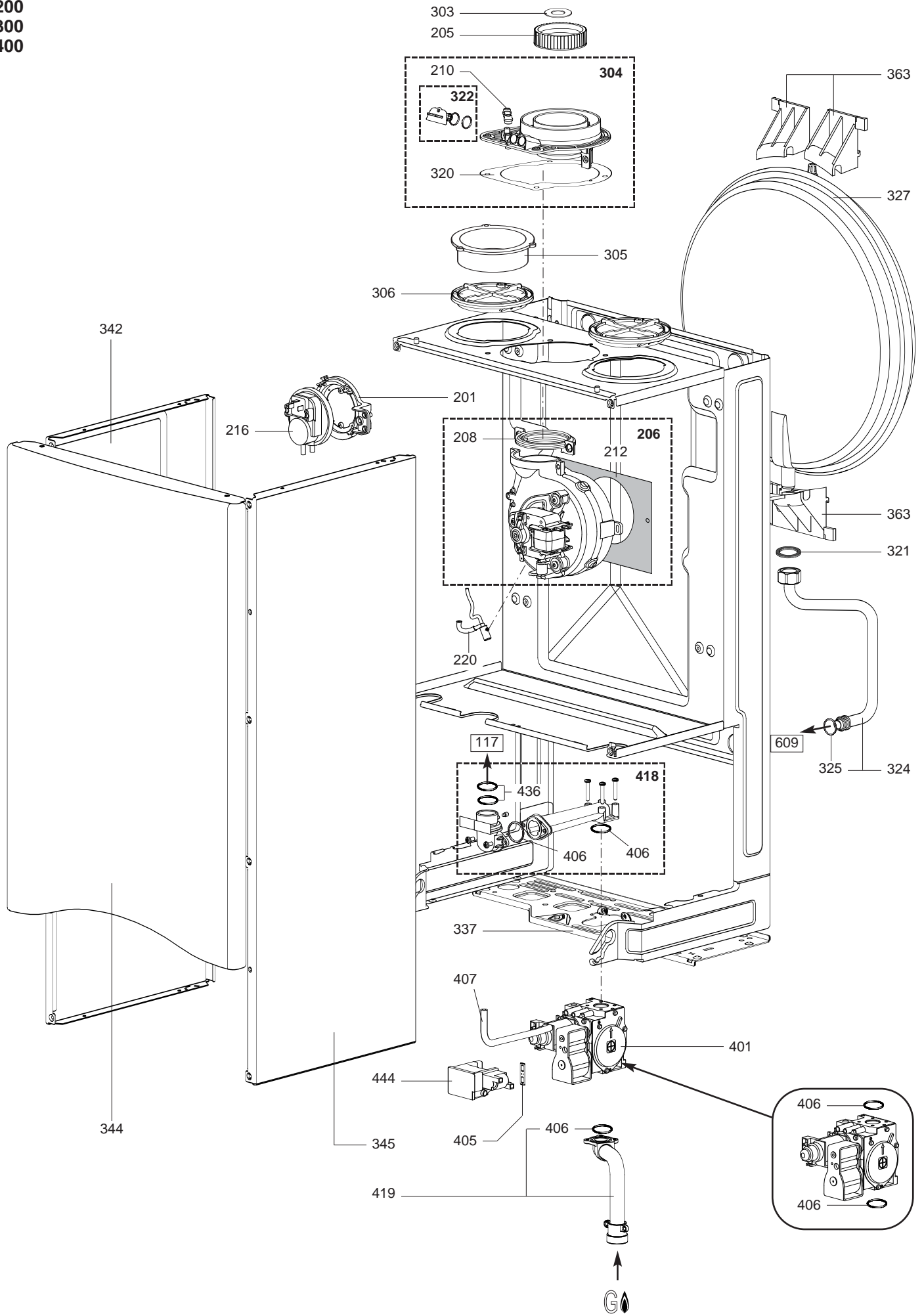

Key N	Description	Manf. Pt. N	Type	EGIS		AS		Manf. date	
				FF	CF	FF	CF	from	to
0200	FAN ASSEMBLY								
0201	SUPPORT (AIR PRESSURE SWITCH)	65104378		●	●				
0206	FAN	65104357		●	●				
0208	FAN GASKET	65104257		●	●				
0209	VENTURI	65106516		●	●				
0210	AIR INTAKE COVER	573329		●	●				
0212	PANEL (INSULATION - FAN)	65104305		●	●				
0216	AIR PRESSURE SWITCH	65104671		●	●				
0220	CONDENSATE TRAP	65104623		●	●				
0300	CHASSIS-FRONT CASE								
0303	RESTRICTOR (D=44)	65105078		●	●				
0304	FLUE (EXHAUST MANIFOLD / HEADER)	65105393		●	●				
0305	AIR RETURN MANIFOLD	65104710		●	●				
0306	AIR RETURN COVER	65104249		●	●				
0320	GASKET	60000317		●	●				
0321	GASKET 3/8	573521		●	●	●	●		
0322	FLUE INTAKE PLUG	65104295		●	●				
0324	PIPE (EXPANSION VESSEL)	65104253		●	●	●	●		
0325	O-RING D: 8.9-2.7	61009834-14		●	●	●	●		
0327	EXPANSION VESSEL	65104261		●	●	●	●		
0337	HYDRAULIC GROUP SUPPORT	65104311		●	●	●	●		
0342	CASE PANEL (L.H. SIDE)	65104242		●	●	●	●		05/07
	CASE PANEL (L.H. SIDE)	65105676		●	●	●	●	06/07	
0344	CASE PANEL (FRONT)	65104299		●	●	●	●		
0345	CASE PANEL (R.H. SIDE)	65104241		●	●	●	●		05/07
	CASE PANEL (R.H. SIDE)	65105677		●	●	●	●	06/07	
0363	EXPANSION VESSEL SUPPORT	65104696		●	●	●	●		
0400	GAS SECTION								
0401	GAS VALVE	65104254		●	●	●	●		
0405	GASKET (SPARK GENERATOR)	574279		●	●	●	●		
0406	O-RING 22,22X2,62	65104304		●	●	●	●		
0407	SILICONE PIPE	65104296		●	●	●	●		
0418	PIPE (GAS VALVE/BURNER)	65104230		●	●	●	●		
0419	GAS PIPE	65104251		●	●	●	●		
0436	O-RING 17,17X1,78	65104303		●	●	●	●		
0444	SPARK GENERATOR	65104653		●	●	●	●		

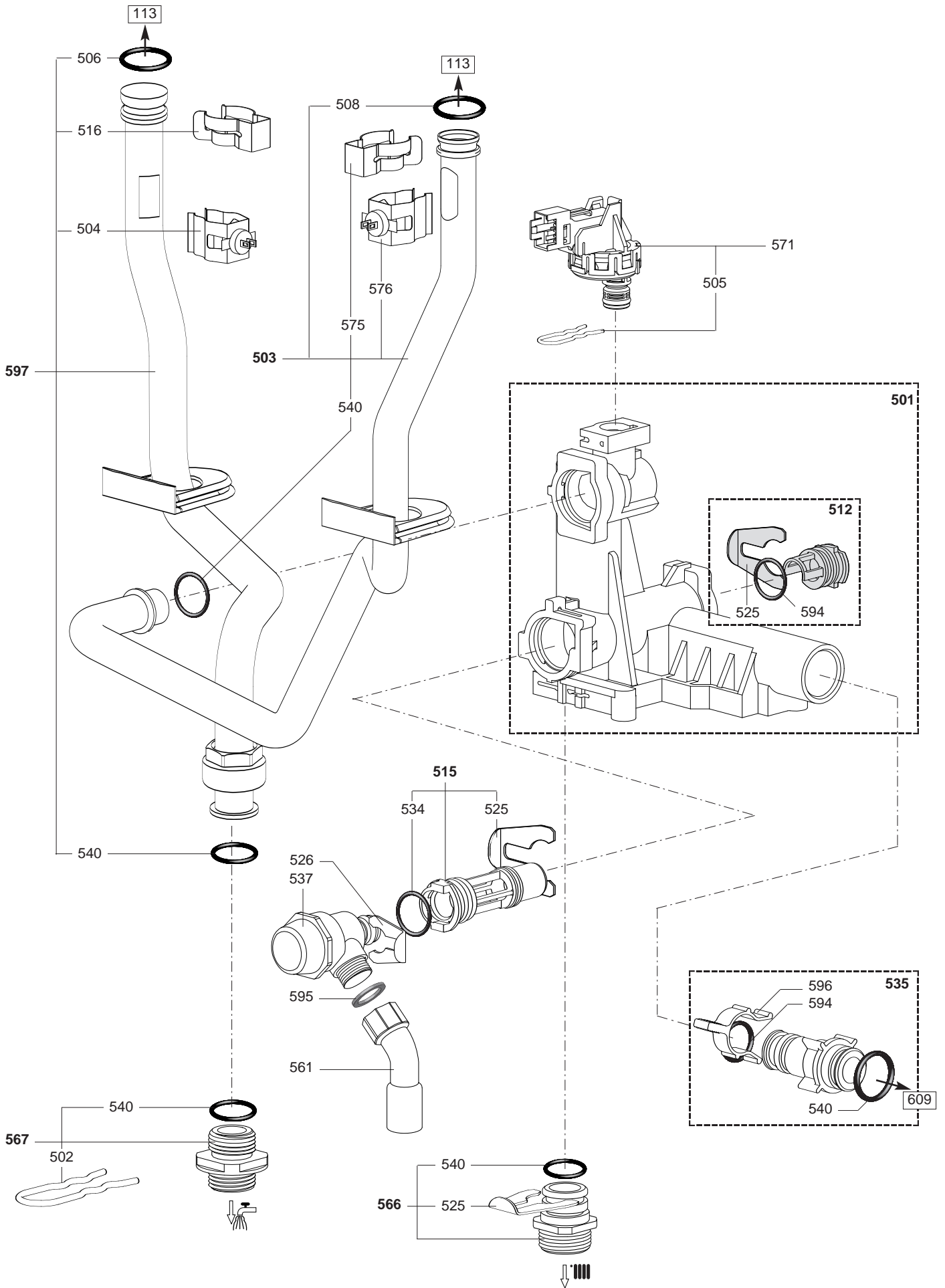

Key N	Description	Manf. Pt. N	Type	EGIS		AS		Manf. date	
				FF	CF	FF	CF	from	to
0500	FLOW GROUP								
0501	FLOW GROUP	65105091		•	•	•	•		
0502	CLIP	65104332		•	•	•	•		
0503	PIPE (C.H. FLOW)	65105106		•		•			02/08
	PIPE (C.H. FLOW)	65105106			•		•		
	PIPE (C.H. FLOW)	65106307		•		•		03/08	
0504	TEMPERATURE PROBE + CLIP	65105079		•	•	•	•		
0505	CLIP	65104322		•	•	•	•		
0506	O - RING (13X2)	65105108		•	•	•	•		
0508	O-RING 3,53X17,04	65104262		•	•	•	•		
0512	PLUG	65104445		•	•	•	•		
0515	BY-PASS	65104336		•	•	•	•		
0516	CLIP	65105109		•	•	•	•		
0525	CLIP D=18	65104259		•	•	•	•		
0526	CLIP D:10	65104260		•	•	•	•		
0534	O - RING (15.88X2.62)	65104337		•	•	•	•		
0535	BY-PASS PIPE	65104340		•	•	•	•		
0537	PRESSURE RELIEF VALVE	61312668		•	•	•	•		
0540	O-RING D: 17.86-2.62	61308091		•	•	•	•		
0561	PIPE (SAFETY VALVE)	65104447		•	•	•	•		
0566	UNION (3/4)	65104326		•	•	•	•		
0567	UNION (1/2)	65105121		•	•	•	•		
0571	LOW PRESSURE SWITCH	65105090		•	•	•	•		
0575	CLIP	61307589		•	•	•	•		
0576	TEMPERATURE PROBE + CLIP	990686		•	•	•	•		
0594	O - RING (15.54X2.62)	65104325		•	•	•	•		
0595	SHEET GASKET D: 13.9-10.4-1.5	60061853-02		•	•				
0596	CLIP (BY-PASS PIPE)	65104700		•	•	•	•		
0597	DOMESTIC HOT WATER DELIVERY PIPE	65105107		•		•			02/08
	DOMESTIC HOT WATER DELIVERY PIPE	65105107			•		•		
	DOMESTIC HOT WATER DELIVERY PIPE	65106304		•		•		03/08	

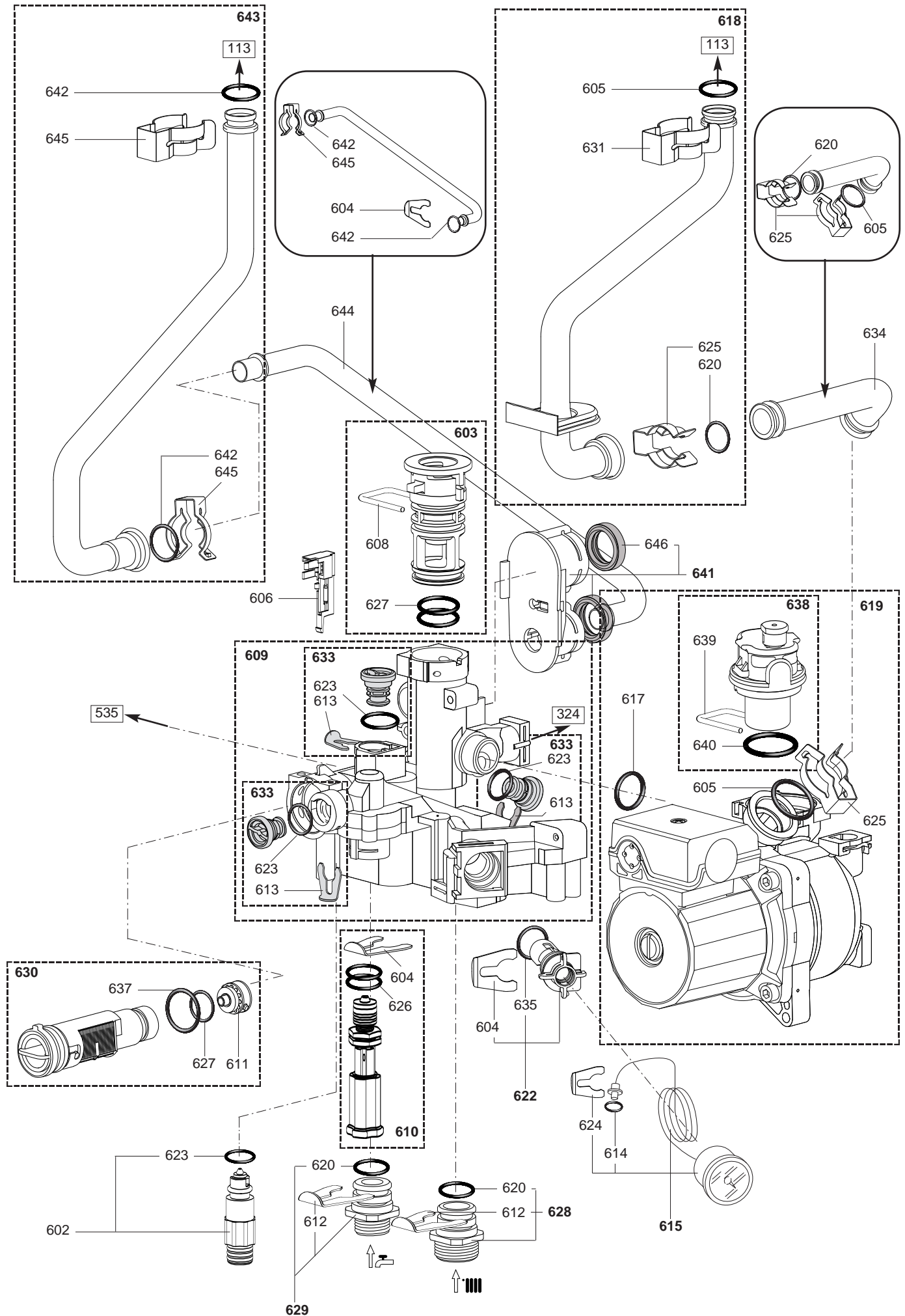

Key N	Description	Manf. Pt. N	Type	EGIS		AS		Manf. date	
				FF	CF	FF	CF	from	to
0600	RETURN GROUP								
0602	DRAIN COCK	65104328		•	•	•	•		
0603	PLUG	65105093		•	•	•	•		
0604	CLIP	65104331		•	•	•	•		
0605	O-RING 3,53X17,04	65104262		•	•	•	•		
0606	SENSOR (REED)	65104323		•	•	•	•		
0608	CLIP	65104316		•	•	•	•		
0609	RETURN GROUP	65104335		•	•	•	•		
	RETURN GROUP	65105322				•	•		
	RETURN GROUP	65105689		•	•				
0610	FILLING TAP KIT	65104324		•	•	•	•		
0611	RIDUCTORS (KIT)	65104318	8-10-12 LT	•	•	•	•		
0612	CLIP D=18	65104259		•	•	•	•		
0613	CLIP D:10	65104260		•	•	•	•		
0614	O RING D: 5.7-1.9	61009834-10		•	•	•	•		
0615	PRESSURE GAUGE	65104234		•	•	•	•		
0617	O - RING (21.89X2.62)	65104320		•	•	•	•		
0618	PIPE (C.H. RETURN)	65105102		•		•			02/08
	PIPE (C.H. RETURN)	65105102			•		•		
	PIPE (C.H. RETURN)	65106306		•		•		03/08	
0619	PUMP	65105039		•	•	•	•		
0620	O-RING D: 17.86-2.62	61308091		•	•	•	•		
0622	WATER FILTER	65104711		•	•	•	•		
0623	O - RING (9.19X2.62)	65104313		•	•	•	•		
0624	CLIP	65100680		•	•	•	•		
0625	CLIP	60000309		•	•	•	•		
0626	O - RING (1.78X8.74)	65104329		•	•	•	•		
0627	O - RING (23.47X2.62)	65104315		•	•	•	•		
0628	UNION (3/4)	65104326		•	•	•	•		
0629	UNION (1/2)	65104327		•	•	•	•		
0630	FLOW METER	65104317		•	•	•	•		
0631	CLIP	61307589		•	•	•	•		
0633	PLUG	65104377		•	•	•	•		
0634	UNION (PUMP - PIPE)	65105103		•	•	•	•		
0635	O - RING (15.54X2.62)	65104325		•	•	•	•		
0636	CHECK VALVE CARTRIDGE	65105323		•	•	•	•		
0637	O-RING 17,17X1,78	65104303		•	•	•	•		
0638	AUTO AIR VENT WITH O-RING	65104703		•	•	•	•		
0639	U-CLIP	65104704		•	•	•	•		
0640	O-RING	65104705		•	•	•	•		
0641	INTERFACE	65105092		•	•	•	•		
0642	O - RING (13X2)	65105108		•	•	•	•		
0643	DOMESTIC HOT WATER DELIVERY PIPE	65105104		•		•			02/08
	DOMESTIC HOT WATER DELIVERY PIPE	65105104			•		•		
	DOMESTIC HOT WATER DELIVERY PIPE	65106305		•		•		03/08	
0644	UNION (PIPE - DELIVERY GROUP)	65106290		•	•	•	•	12/07	
	UNION (PIPE - DELIVERY GROUP)	65105105		•	•	•	•		11/07
0645	CLIP	65105109		•	•	•	•		
0646	EXCHANGER GASKET	65104334		•	•	•	•		

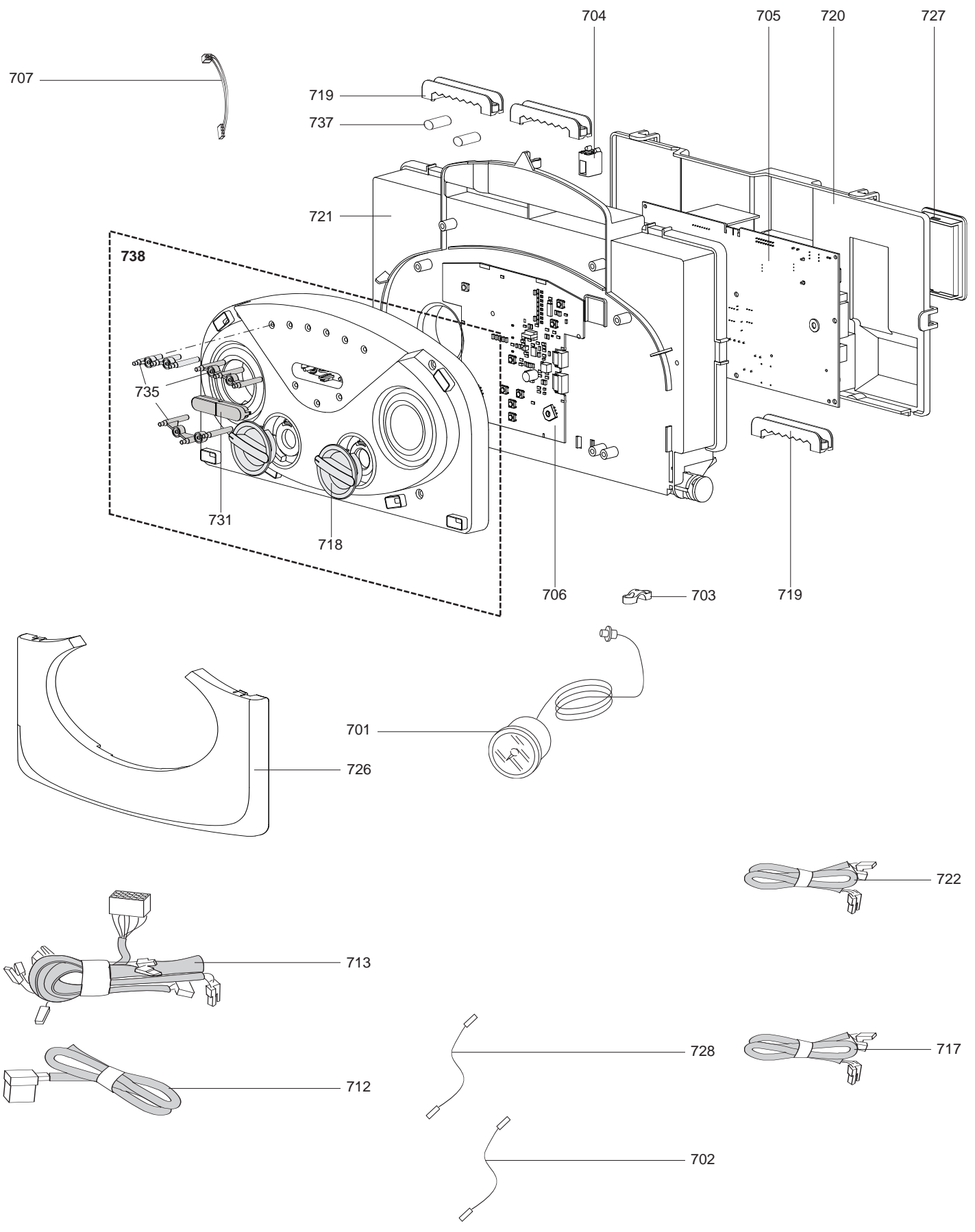

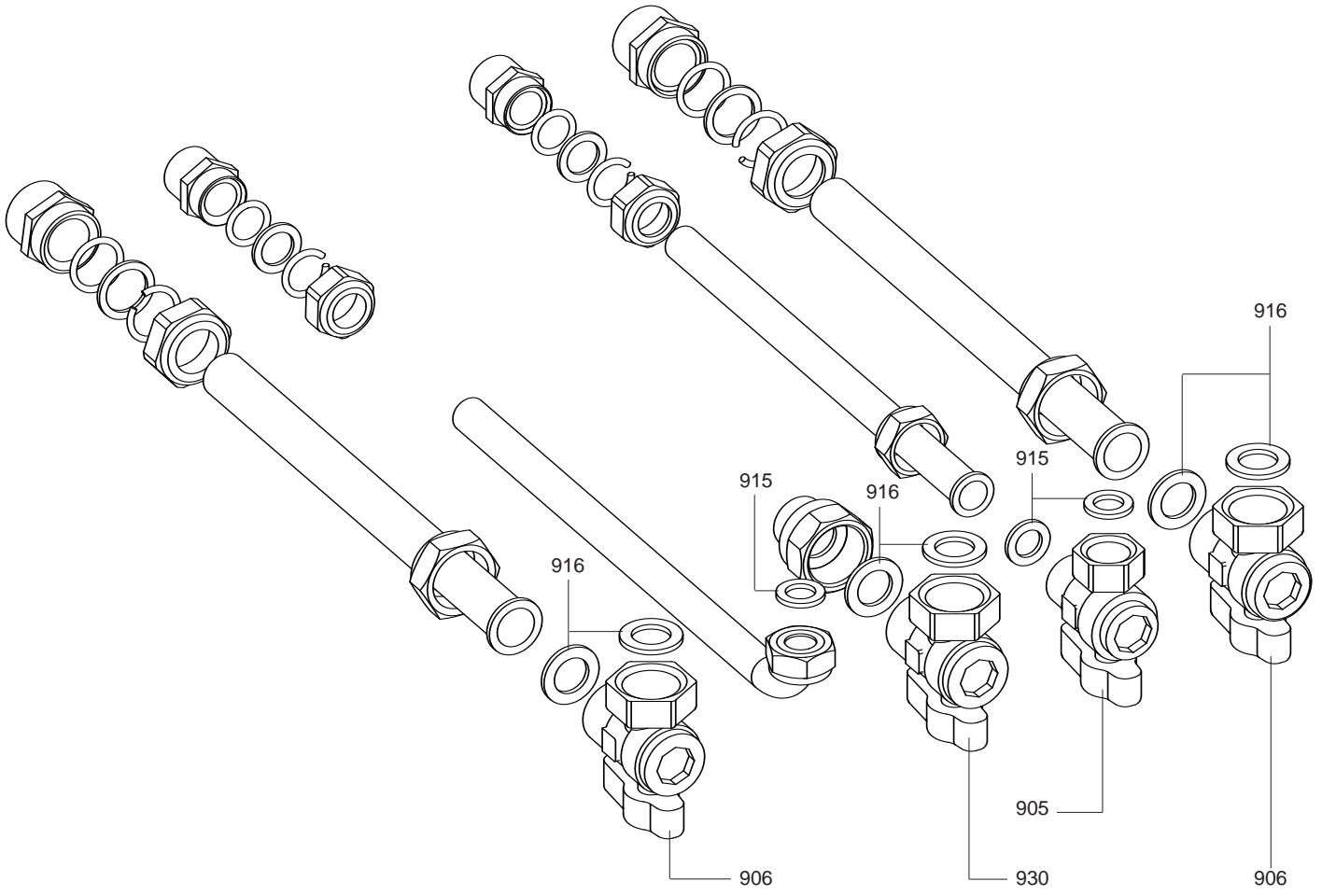

5000

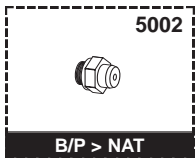
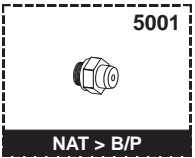

LIST OF THE ABBREVIATIONS

HW	: Hot water.
CW	: Cold water.
C	: Ceramic resistance (normal heating).
Ca	: Ceramic resistance (accelerated heating)
TP	: Immersion heater.
1F	: With fittings.
2F	: Without fittings.
3F	: With fittings and another outlet connection.
AMI	: With mixing valve.
SMI	: Without mixing valve.
PUISS	: Power of th appliance.
PN	: Appliance with normal pression.
LP	: Appliance with low pression.
PV	: Appliance with variable power.
PF	: Appliance with fixed power..

IDENTIFICATION PLATE

SERIAL NUMBER

Ex: 0537095 XX 2 04 070 00315

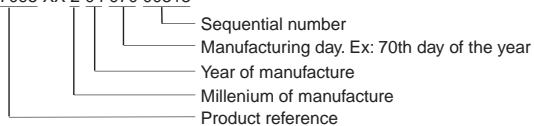

The indications mentioned on the prices, commercial or technical literature and the scheme are written for your guidance and are available at a given time. The CONSTRUCTOR retains the power to modify the presentation, the form, the size, the conception or the material of the products.