

SEMiX303GB12E4s



SEMiX[®] 3s

Trench IGBT Modules

SEMiX303GB12E4s

Features

- Homogeneous Si
- Trench = Trenchgate technology
- $V_{CE(sat)}$ with positive temperature coefficient
- High short circuit capability
- UL recognized, file no. E63532

Typical Applications*

- AC inverter drives
- UPS
- Electronic Welding

Remarks

- Case temperature limited to $T_C = 125^\circ\text{C}$ max.
- Product reliability results are valid for $T_j = 150^\circ\text{C}$
- Dynamic values apply to the following combination of resistors:
 $R_{Gon,main} = 1,0 \Omega$
 $R_{Goff,main} = 1,0 \Omega$
 $R_{G,X} = 2,0 \Omega$
 $R_{E,X} = 0,5 \Omega$

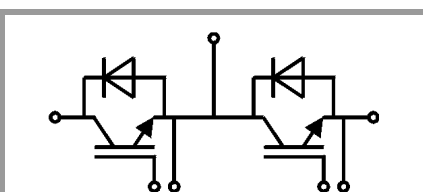

GB

| Absolute Maximum Ratings | | | | |
|--------------------------|--|---------------------------|------------------|---------------|
| Symbol | Conditions | Values | Unit | |
| IGBT | | | | |
| V_{CES} | | 1200 | V | |
| I_C | $T_j = 175^\circ\text{C}$ | $T_c = 25^\circ\text{C}$ | 466 | A |
| | | $T_c = 80^\circ\text{C}$ | 359 | A |
| I_{Cnom} | | 300 | A | |
| I_{CRM} | $I_{CRM} = 3 \times I_{Cnom}$ | 900 | A | |
| V_{GES} | | -20 ... 20 | V | |
| t_{psc} | $V_{CC} = 800\text{ V}$ | $T_j = 150^\circ\text{C}$ | 10 | μs |
| | $V_{GE} \leq 20\text{ V}$ | | | |
| | $V_{CES} \leq 1200\text{ V}$ | | | |
| T_j | | -40 ... 175 | $^\circ\text{C}$ | |
| Inverse diode | | | | |
| I_F | $T_j = 175^\circ\text{C}$ | $T_c = 25^\circ\text{C}$ | 338 | A |
| | | $T_c = 80^\circ\text{C}$ | 252 | A |
| I_{Fnom} | | 300 | A | |
| I_{FRM} | $I_{FRM} = 3 \times I_{Fnom}$ | 900 | A | |
| I_{FSM} | $t_p = 10\text{ ms, sin } 180^\circ, T_j = 25^\circ\text{C}$ | 1485 | A | |
| T_j | | -40 ... 175 | $^\circ\text{C}$ | |
| Module | | | | |
| $I_{t(RMS)}$ | $T_{terminal} = 80^\circ\text{C}$ | 600 | A | |
| T_{stg} | | -40 ... 125 | $^\circ\text{C}$ | |
| V_{isol} | AC sinus 50Hz, t = 1 min | 4000 | V | |

| Characteristics | | | | | |
|-----------------|---|---------------------------|------|-------|------------------|
| Symbol | Conditions | min. | typ. | max. | Unit |
| IGBT | | | | | |
| $V_{CE(sat)}$ | $I_C = 300\text{ A}$ $V_{GE} = 15\text{ V}$ chipelevel | $T_j = 25^\circ\text{C}$ | 1.8 | 2.05 | V |
| | | $T_j = 150^\circ\text{C}$ | 2.2 | 2.4 | V |
| V_{CE0} | | $T_j = 25^\circ\text{C}$ | 0.8 | 0.9 | V |
| | | $T_j = 150^\circ\text{C}$ | 0.7 | 0.8 | V |
| r_{CE} | $V_{GE} = 15\text{ V}$ | $T_j = 25^\circ\text{C}$ | 3.3 | 3.8 | $\text{m}\Omega$ |
| | | $T_j = 150^\circ\text{C}$ | 5.0 | 5.3 | $\text{m}\Omega$ |
| $V_{GE(th)}$ | $V_{GE} = V_{CE}, I_C = 11.4\text{ mA}$ | 5 | 5.8 | 6.5 | V |
| I_{CES} | $V_{GE} = 0\text{ V}$ $V_{CE} = 1200\text{ V}$ | $T_j = 25^\circ\text{C}$ | 0.1 | 0.3 | mA |
| | | $T_j = 150^\circ\text{C}$ | | | mA |
| C_{ies} | $V_{CE} = 25\text{ V}$ | | 18.5 | | nF |
| C_{oes} | $V_{GE} = 0\text{ V}$ | | 1.22 | | nF |
| C_{res} | | | 1.03 | | nF |
| Q_G | $V_{GE} = -8\text{ V} \dots +15\text{ V}$ | | 1695 | | nC |
| R_{Gint} | $T_j = 25^\circ\text{C}$ | | 2.50 | | Ω |
| $t_{d(on)}$ | $V_{CC} = 600\text{ V}$ $I_C = 300\text{ A}$ | $T_j = 150^\circ\text{C}$ | 255 | | ns |
| t_r | $V_{GE} = \pm 15\text{ V}$ | $T_j = 150^\circ\text{C}$ | 57 | | ns |
| E_{on} | $R_{Gon} = 1.8\ \Omega$ | $T_j = 150^\circ\text{C}$ | 30 | | mJ |
| $t_{d(off)}$ | $R_{Goff} = 1.8\ \Omega$ | $T_j = 150^\circ\text{C}$ | 565 | | ns |
| t_f | $di/dt_{on} = 5250\text{ A}/\mu\text{s}$ $di/dt_{off} = 2825\text{ A}/\mu\text{s}$ | $T_j = 150^\circ\text{C}$ | 98 | | ns |
| E_{off} | | $T_j = 150^\circ\text{C}$ | 41.2 | | mJ |
| $R_{th(j-c)}$ | per IGBT | | | 0.095 | K/W |

SEMiX303GB12E4s



SEMiX® 3s

Trench IGBT Modules

SEMiX303GB12E4s

Features

- Homogeneous Si
- Trench = Trenchgate technology
- $V_{CE(sat)}$ with positive temperature coefficient
- High short circuit capability
- UL recognized, file no. E63532

Typical Applications*

- AC inverter drives
- UPS
- Electronic Welding

Remarks

- Case temperature limited to $T_C=125^\circ\text{C}$ max.
- Product reliability results are valid for $T_j=150^\circ\text{C}$
- Dynamic values apply to the following combination of resistors:
 $R_{Gon,main} = 1,0 \Omega$
 $R_{Goff,main} = 1,0 \Omega$
 $R_{G,X} = 2,0 \Omega$
 $R_{E,X} = 0,5 \Omega$

| Characteristics | | | | | | |
|--------------------------|--|---------------------------|------|----------------|------|---------------|
| Symbol | Conditions | | min. | typ. | max. | Unit |
| Inverse diode | | | | | | |
| $V_F = V_{EC}$ | $I_F = 300 \text{ A}$ $V_{GE} = 0 \text{ V}$ chip | $T_j = 25^\circ\text{C}$ | | 2.2 | 2.52 | V |
| | | $T_j = 150^\circ\text{C}$ | | 2.2 | 2.5 | V |
| V_{F0} | | $T_j = 25^\circ\text{C}$ | 1.1 | 1.3 | 1.5 | V |
| | | $T_j = 150^\circ\text{C}$ | 0.7 | 0.9 | 1.1 | V |
| r_F | | $T_j = 25^\circ\text{C}$ | 2.7 | 3.0 | 3.4 | m Ω |
| | | $T_j = 150^\circ\text{C}$ | 3.5 | 4.2 | 4.6 | m Ω |
| I_{RRM} | $I_F = 300 \text{ A}$ | $T_j = 150^\circ\text{C}$ | | 300 | | A |
| Q_{rr} | $di/dt_{off} = 5100 \text{ A}/\mu\text{s}$ $V_{GE} = -15 \text{ V}$ | $T_j = 150^\circ\text{C}$ | | 44.2 | | μC |
| E_{rr} | $V_{CC} = 600 \text{ V}$ | $T_j = 150^\circ\text{C}$ | | 17.7 | | mJ |
| $R_{th(j-c)}$ | per diode | | | | 0.18 | K/W |
| Module | | | | | | |
| L_{CE} | | | | 20 | | nH |
| $R_{CC'+EE'}$ | res., terminal-chip | $T_C = 25^\circ\text{C}$ | | 0.7 | | m Ω |
| | | $T_C = 125^\circ\text{C}$ | | 1 | | m Ω |
| $R_{th(c-s)}$ | per module | | | 0.04 | | K/W |
| M_s | to heat sink (M5) | | 3 | | 5 | Nm |
| M_t | to terminals (M6) | | 2.5 | | 5 | Nm |
| | | | | | | |
| w | | | | | 300 | g |
| Temperatur Sensor | | | | | | |
| R_{100} | $T_C=100^\circ\text{C}$ ($R_{25}=5 \text{ k}\Omega$) | | | $493 \pm 5\%$ | | Ω |
| $B_{100/125}$ | $R(T)=R_{100}\exp[B_{100/125}(1/T-1/T_{100})]$; $T[\text{K}]$ | | | $3550 \pm 2\%$ | | K |

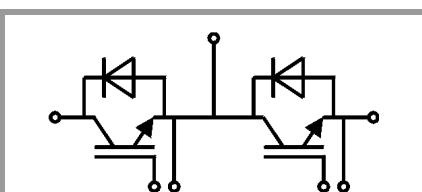

GB

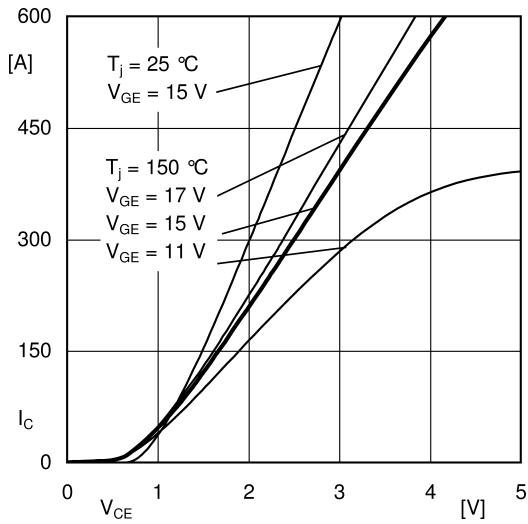

Fig. 1: Typ. output characteristic, inclusive $R_{CC'+EE'}$

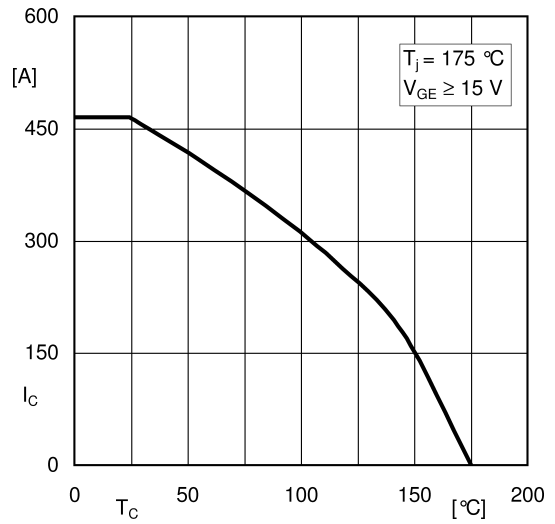

Fig. 2: Rated current vs. temperature $I_C = f(T_C)$

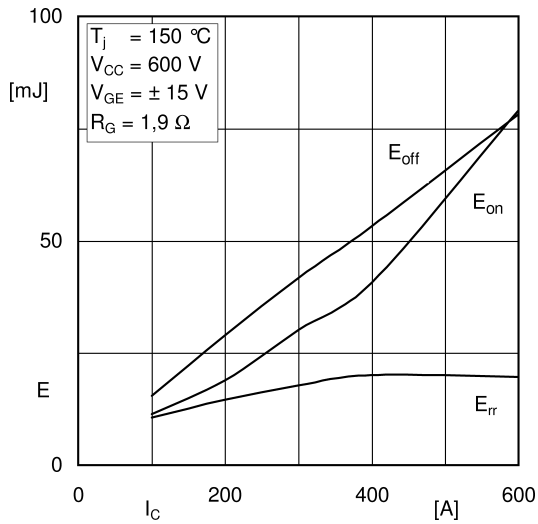

Fig. 3: Typ. turn-on /-off energy = $f(I_C)$

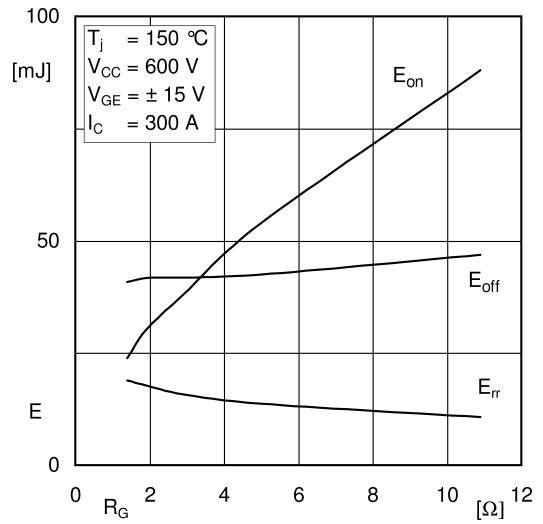

Fig. 4: Typ. turn-on /-off energy = $f(R_G)$

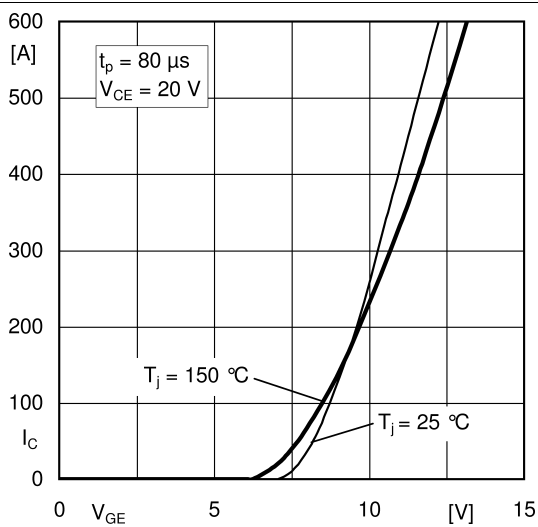

Fig. 5: Typ. transfer characteristic

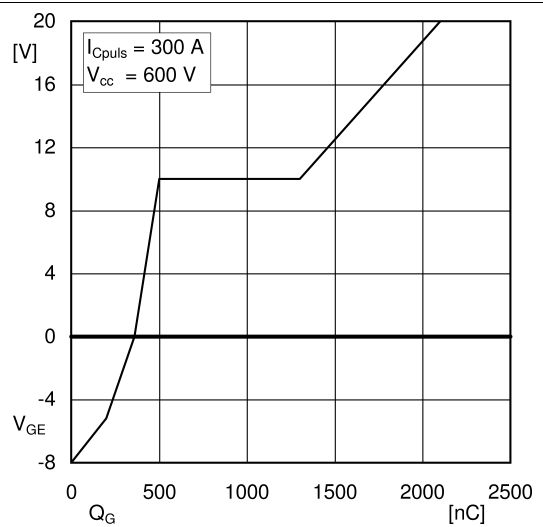

Fig. 6: Typ. gate charge characteristic

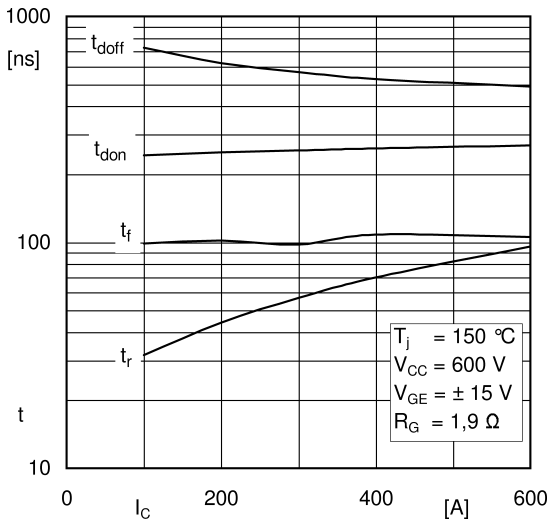

Fig. 7: Typ. switching times vs. I_C

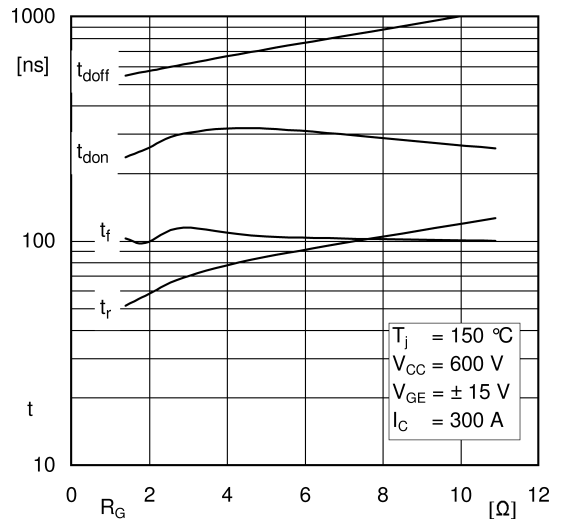

Fig. 8: Typ. switching times vs. gate resistor R_G

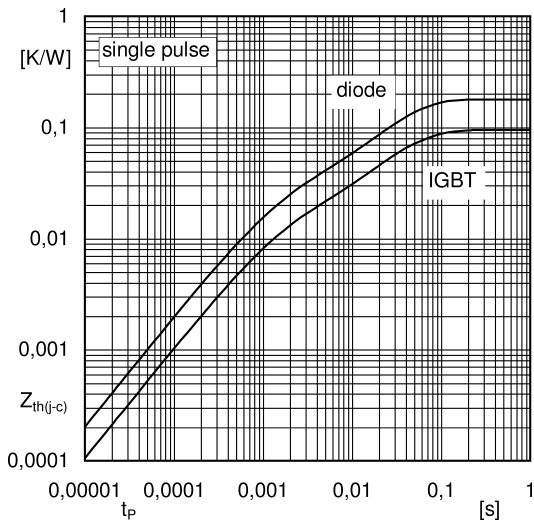

Fig. 9: Typ. transient thermal impedance

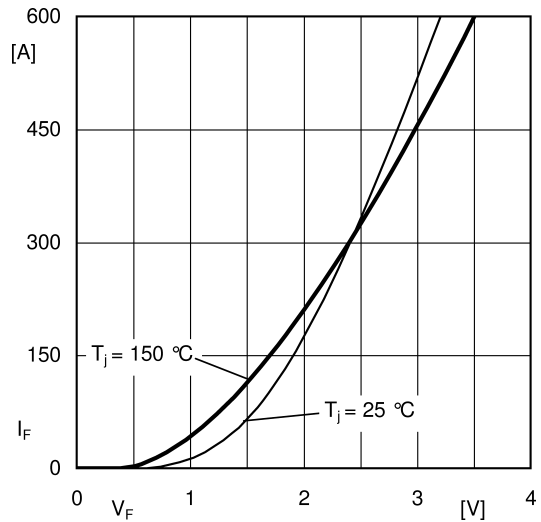

Fig. 10: Typ. CAL diode forward charact., incl. R_{CC+EE}

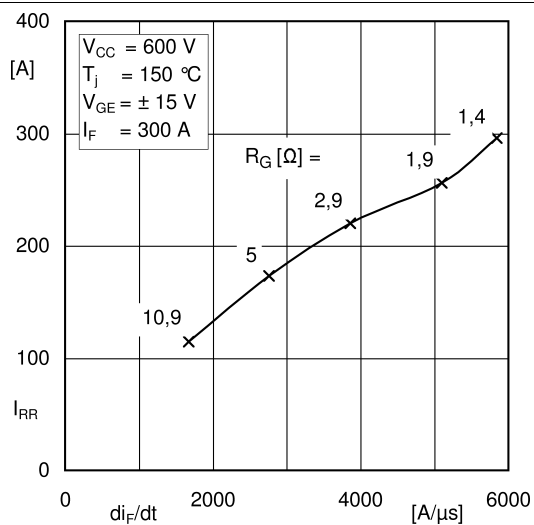

Fig. 11: Typ. CAL diode peak reverse recovery current

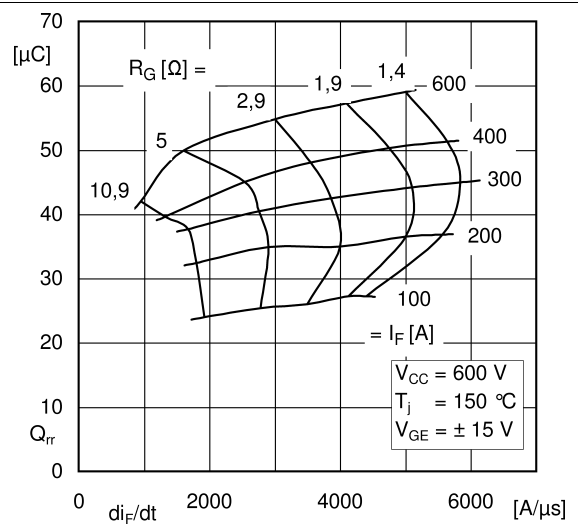
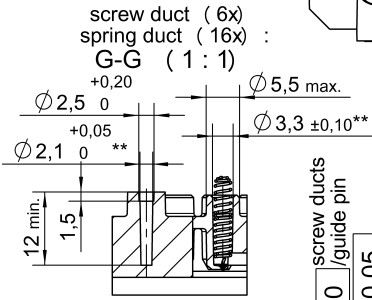
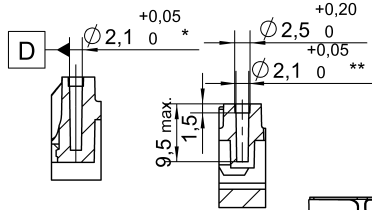

Fig. 12: Typ. CAL diode recovery charge

SEMiX303GB12E4s

Case: SEMiX 3s

screw duct (left top) : F-F (1:1)
 screw duct (1x centre) : H-H (1:1)



| | | |
|-------------|-----|---------------------|
| \square | 0,3 | connector 1-2 / 3-4 |
| \parallel | 0,2 | each connector A |

general tolerance:
 ISO 2768-mK
 ISO 8015

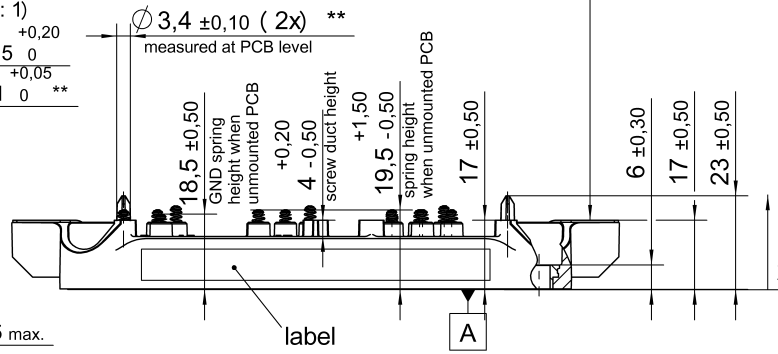

All measures in Z-direction valid when mounted to heat sink

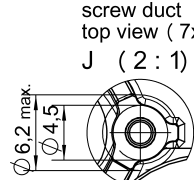
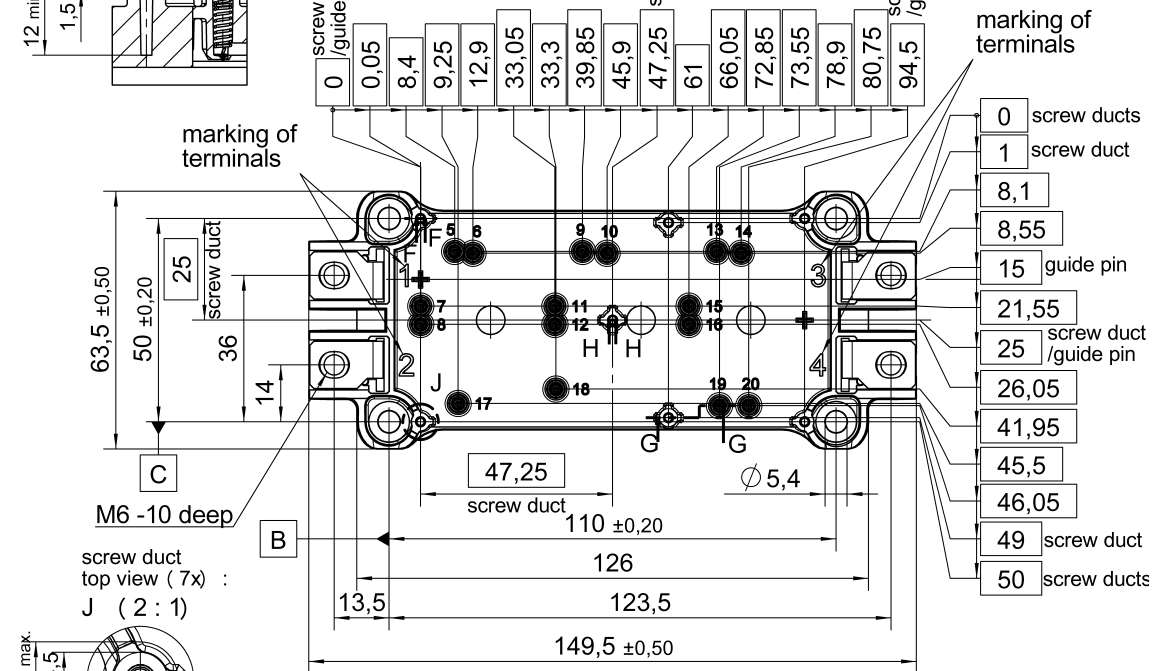

| | | | | | | |
|--|----------|------------|---|---|---|---|
| *screw duct left / top with | \oplus | ϕ 0,2 | A | B | C | Rules for the contact PCB: - holes guidepins = ϕ 4 ± 0,1 / position tolerance ± 0,1 - holes for screws = ϕ 2,9 ± 0,1 / position tolerance ± 0,1 - spring contact pad = ϕ 3,6 ± 0,1 / position tolerance ± 0,1 |
| **screw ducts / guide pins / spring ducts with | \oplus | ϕ 0,2 | A | D | C | |

SEMiX 3s

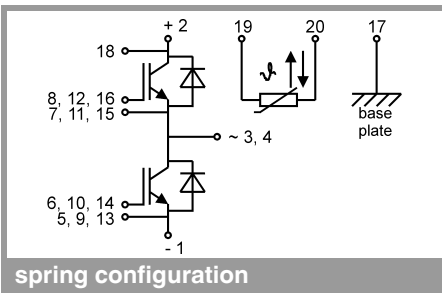

spring configuration

This is an electrostatic discharge sensitive device (ESDS), international standard IEC 60747-1, Chapter IX

* The specifications of our components may not be considered as an assurance of component characteristics. Components have to be tested for the respective application. Adjustments may be necessary. The use of SEMIKRON products in life support appliances and systems is subject to prior specification and written approval by SEMIKRON. We therefore strongly recommend prior consultation of our staff.